

# DMS800

DIGITAL WIRELESS MICROPHONE SYSTEM  
**SERVICE MANUAL**

09/15

*Table of contents:*

The complete DSM 800 family	3	Die komplette DMS 800 Familie
DHT 800 Digital handheld transmitter	4	DHT 800 Digitaler Handsender
DPT 800 Digital bodypack transmitter	7	DPT 800 Digitaler Taschensender
DSR 800 Digital stationary receiver	9	DSR 800 Digital Empfänger
CU 800 Charging unit	13	CU 800 Ladegerät

Last modification:

DHT 800  
Digital handheld  
transmitter



DSR 800  
Digital stationary  
receiver



CU 800  
Charging unit



DPT 800  
Digital bodypack  
transmitter



Frequency range, MHz	
BD 1	548.1 - 605.9, 614.1 - 697.9/50 mW
BD 1 AU	548.1 - 605.9, 614.1 - 693.9/50 mW
BD 1 NZ	548.1 - 605.9, 622.1 - 697.9/50 mW
BD 1 UK	548.1 - 697.9/DPT: 50 mW DHT: 10mW
BD 2	710.1 - 785.9, 823.1 - 831.9 MHz/50 mW (10 mW, 823.1 - 825.9)
BD 2 DE	710.1 - 789.9 & 823.1 - 831.9/50 mW

**Mains cable:**

EU 0110E03160  
US 0110E03170

**DSR 800 Antenna:**

Band 1 (long) 9999N07440  
Band 2 (short) 9999N07450  
Front mount cable 0110E01890

DHT 800 3381Z00...

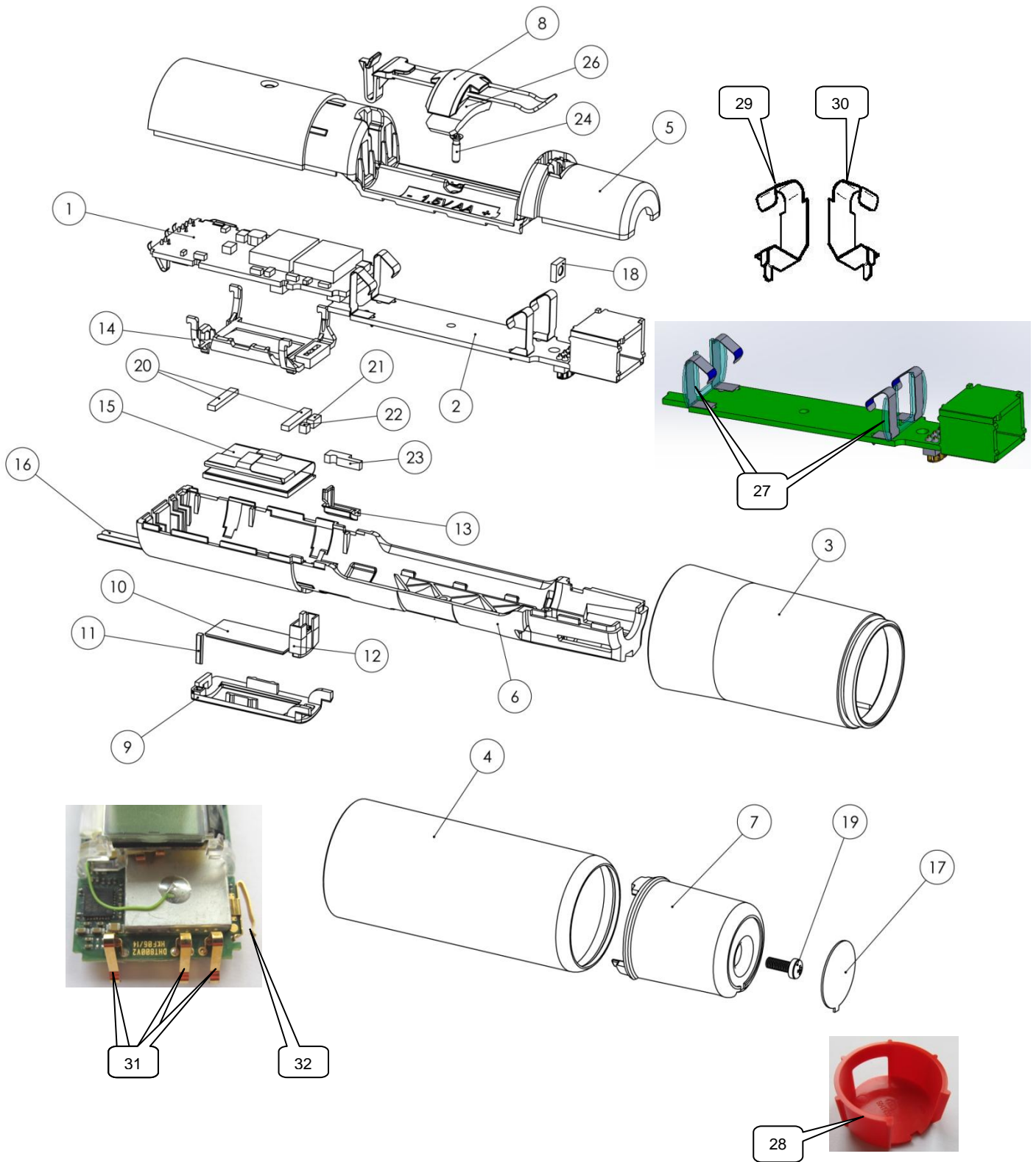

## DHT 800 Parts list / Stückliste

Description	Pos.	Part number Bestellnummer	Quantity Stück		Bezeichnung
			Bd1	Bd2	
Mainboard Bd1	1	5042953	1	-	Hauptprint Bd1
Mainboard Bd2	1	5042954	-	1	Hauptprint Bd2
Antenna Assy. BD1	2	5047203	1	-	Antennenprint BD1
Antenna Assy. BD2	2	5048106	-	1	Antennenprint BD2
Housing	3	5044764	1	1	Gehäuse
Battery sleeve	4	5044765	1	1	Batteriehlse
Shell 1	5	5046959	1	1	Gehäuseschale 1
Shell 2	6	5046960	1	1	Gehäuseschale 2
Antenna cap	7	5046961	1	1	Antennenkappe
Battery clamp	8	5044881	1	1	Batterieklammer
Display frame	9	5046962	1	1	Displayrahmen
Display window	10	3157Z13010	1	1	Displayfenster
Light guide,	11	3157Z32010	1	1	Lichtleiter
Mute button,	12	3157Z14010	1	1	Mute Knopf
On/Off Button	13	3157Z16010	1	1	On/Off Knopf
Display holder,	14	3157Z15010	1	1	Displayhalter
LCD display	15	5060759	1	1	LCD display
Latch	16	5044782	1	1	Riegel
Logo plate	17	5048031	1	1	Logoaufkleber
Square nut M3	18	0562D30000	1	1	Vierkantmutter M3
Screw M3x8	19	7045D30030	1	1	Schraube M3x8
Foam 2	20	3157Z28010	1	1	Schaumstoffstück 2
Foam 3	21	3157Z37010	1	1	Schaumstoffstück 3
Foam 4	22	3157Z38010	1	1	Schaumstoffstück 4
Foam 1	23	3157Z27010	1	1	Schaumstoffstück 1
Screw EJOT PT KB22x8	24	0099N22140	1	1	Schraube EJOT PT KB22x8
Battery bracket foam	26	5050142	1	1	Batteriehalterauflage
Contact retainer <small>behind batt. contacts</small>	27	5057299	2	2	Kontakthalter
CU Adapter DHT800	28	5047432	1	1	Adapter für CU700/800
Battery contact 1	29	5047204	2	2	Batteriekontakt 1
Battery contact 2	30	5047206	2	2	Batteriekontakt 2
Contact spring	31	5044780	3	3	Kontaktfeder
Contact spring	32	5047344	1	1	Kontaktfeder

**Important!**

For ordering the DHT800 main transmitter board we need the following information:

1. Board number: 5042953 for Band1 or 5042954 for Band2
2. Preset programming (please see table below)

Frequency band and power / Frequenzband und Leistung							
Preset →	BD1 50mW	BD1 NZ 50mW	BD1 AU 50mW	BD1 UK 50mW	B2 10/50mW	BD2 DE 50mW	
Mainboard 5042953	x	x	x	x	-	-	
Mainboard 5042954	-	-	-	-	x	x	
Device sticker	5048131	5048135	5048133	5048134	5048136	5048137	

To dismantle the DHT800 proceed as follows:

Remove logo plate and screw



Remove antenna cap and sleeve



Remove latch and display frame with glass and mute knob



Remove screw and housing

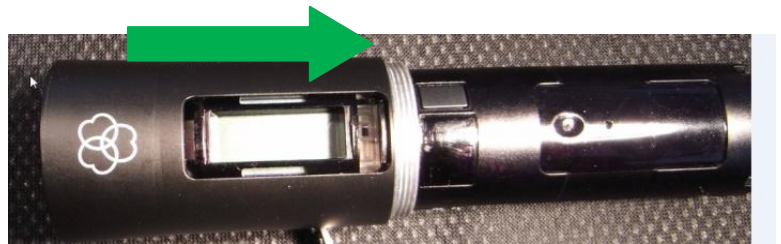

Remove shell

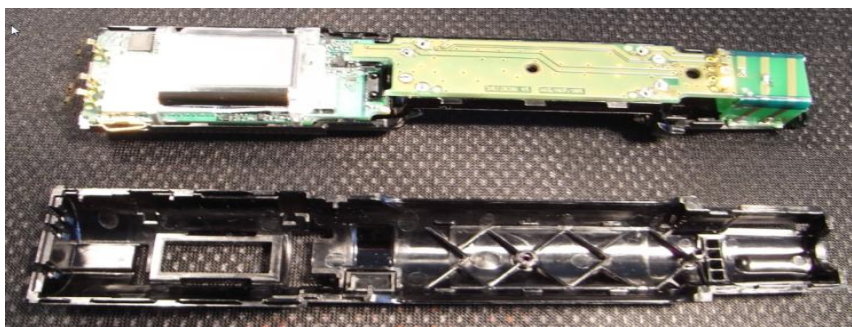

**DPT 800 3382Z00...**

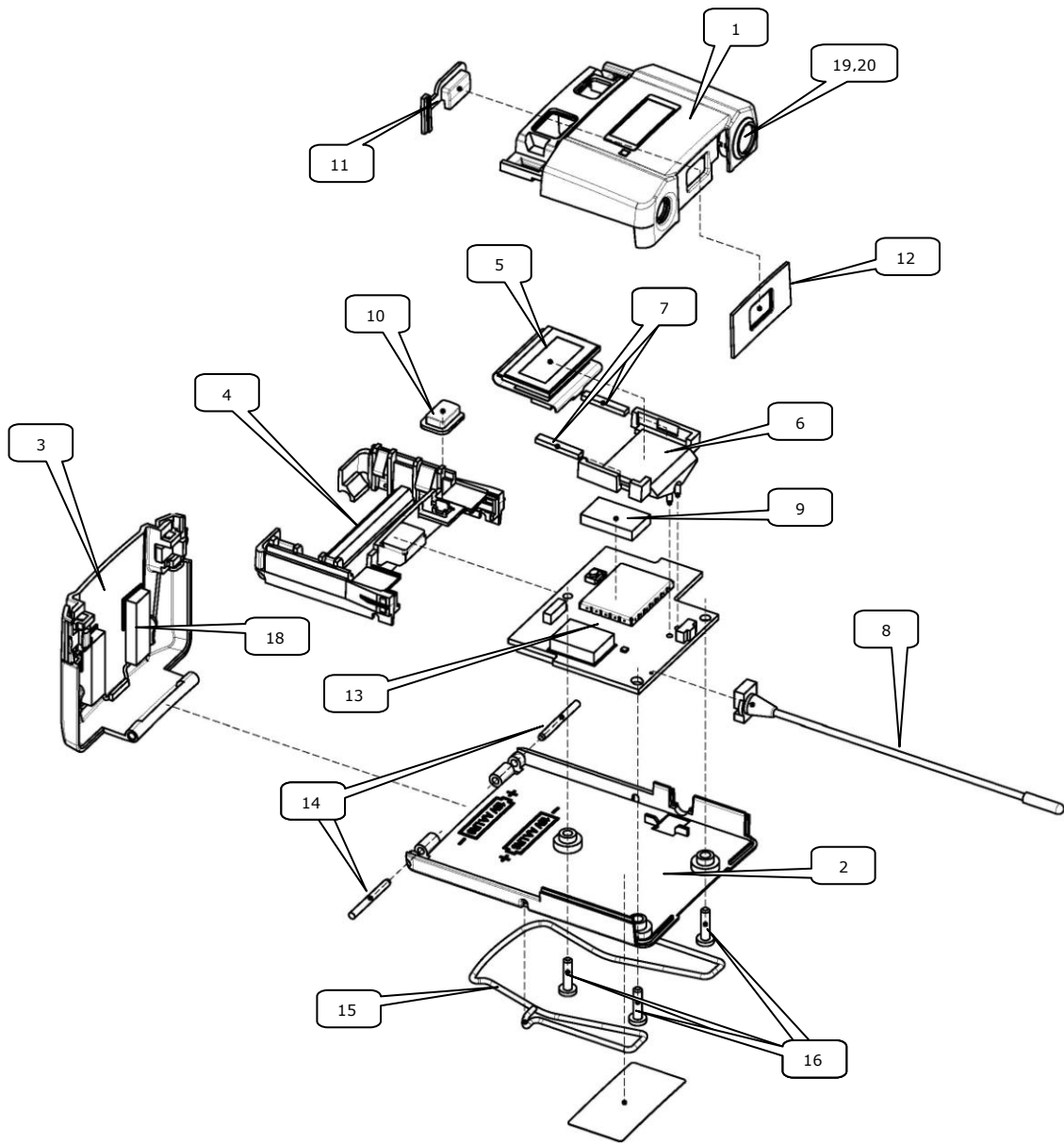

**Wiring / Verkabelung**

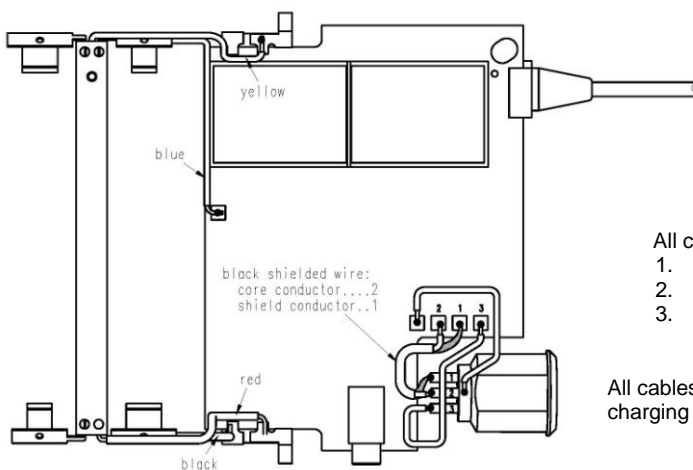

wire loop of antenna overlength (side view)

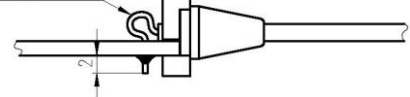

All charging contact solder joints:

1. pre-solder related pads on pcb
2. assemble pcb and frame assy.
3. melt solder by heating up charging contacts with soldering tip (apply some pressure)

All cables from pcb carrier assy. To be soldered directly on charging contacts like shown in this view



## DPT 800 Parts list / Stückliste

Description	Pos.	Part number Bestellnummer	Quantity Stück	Bezeichnung
Housing top assy.*	1	5048282	1	Gehäuseoberteil kompl.*
Housing bottom assy.	2	5048257	1	Gehäuseunterteil
Battery cover assy.	3	5048283	1	Batteriedeckel
Frame assy.	4	3156M12020	1	Rahmen kompl.
LCD display	5	0050E00070	1	LCD Display
Display holder	6	3156Z17010	1	Displayhalter
Foam	7	3157Z28010	2	Schaumstoffstück
Antenna assy. Band 1	8	3156M10030	1	Antenne kompl. Band 1
Antenna assy. Band 2	8	3156M10040	1	Antenne kompl. Band 2
Foam	9	2932Z34010	1	Schaumstoffstück
On/Off button	10	3156Z18010	1	On/Off Knopf
Mute button	11	3156Z19010	1	Mute Knopf
Cover	12	3156Z20010	1	Abdeckung
Mainboard Band 1**	13	5042956	1	Hauptprint Band 1**
Mainboard Band 2**	13	5042957	1	Hauptprint Band 2**
Bolt, DIN7 2h8 x 20mm	14	0007D20050	2	Stift, DIN7 2h8 x 20mm
Belt clip	15	3156Z25010	1	Gürtelklammer
Screw, M2.5x10	16	7045D25030	3	Schraube, M2.5x10
Foam	18	2932Z21010	2	Schaumstoffstück
Mini-XLR socket with wires	19	3156M15010	1	Mini-XLR Buchse
Nut for Mini-XLR socket	20	2781Z20020	1	Mutter für Mini-XLR Buchse

\* Housing top assy. includes display window and Mini-XLR socket.

\*\*Mainboard (13) will always delivered **together** with frame assy.(4)

### Important!

For ordering the DPT800 main transmitter board we need the following information:

1. Board number: 5042956 for Band1 or 5042957 for Band2
2. Preset programming (please see table below)

Frequency band and power / Frequenzband und Leistung							
Preset →	BD1 50mW	BD1 NZ 50mW	BD1 AU 50mW	BD1 UK 10mW	B2 10/50mW	BD2 DE 50mW	
Mainboard 5042956	x	x	x	x	-	-	
Mainboard 5042957	-	-	-	-	x	x	
Device sticker	5048322	5048325	5048323	5048324	5048326	5048327	



DSR 800 3380Z00...

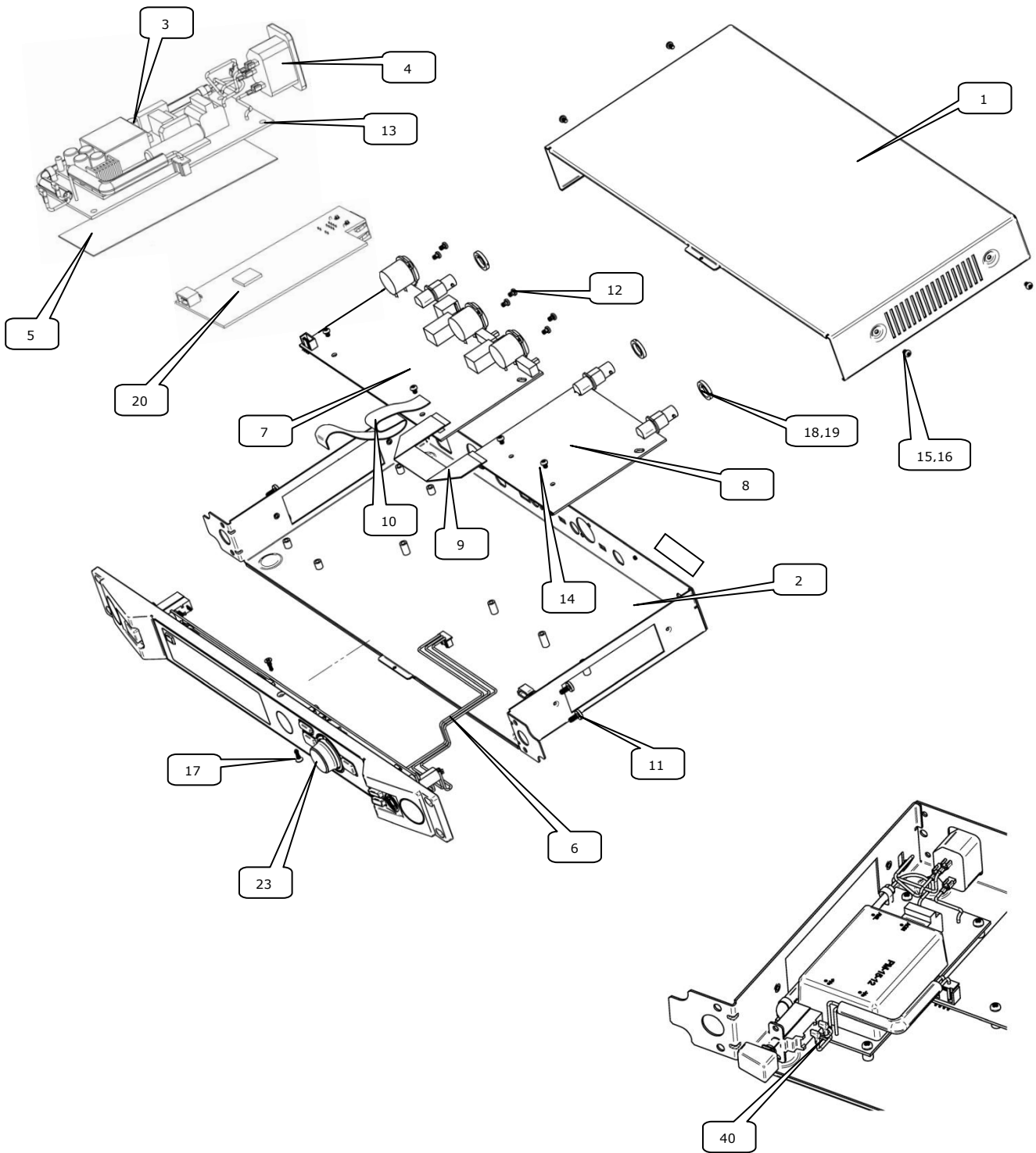

Frontpanel

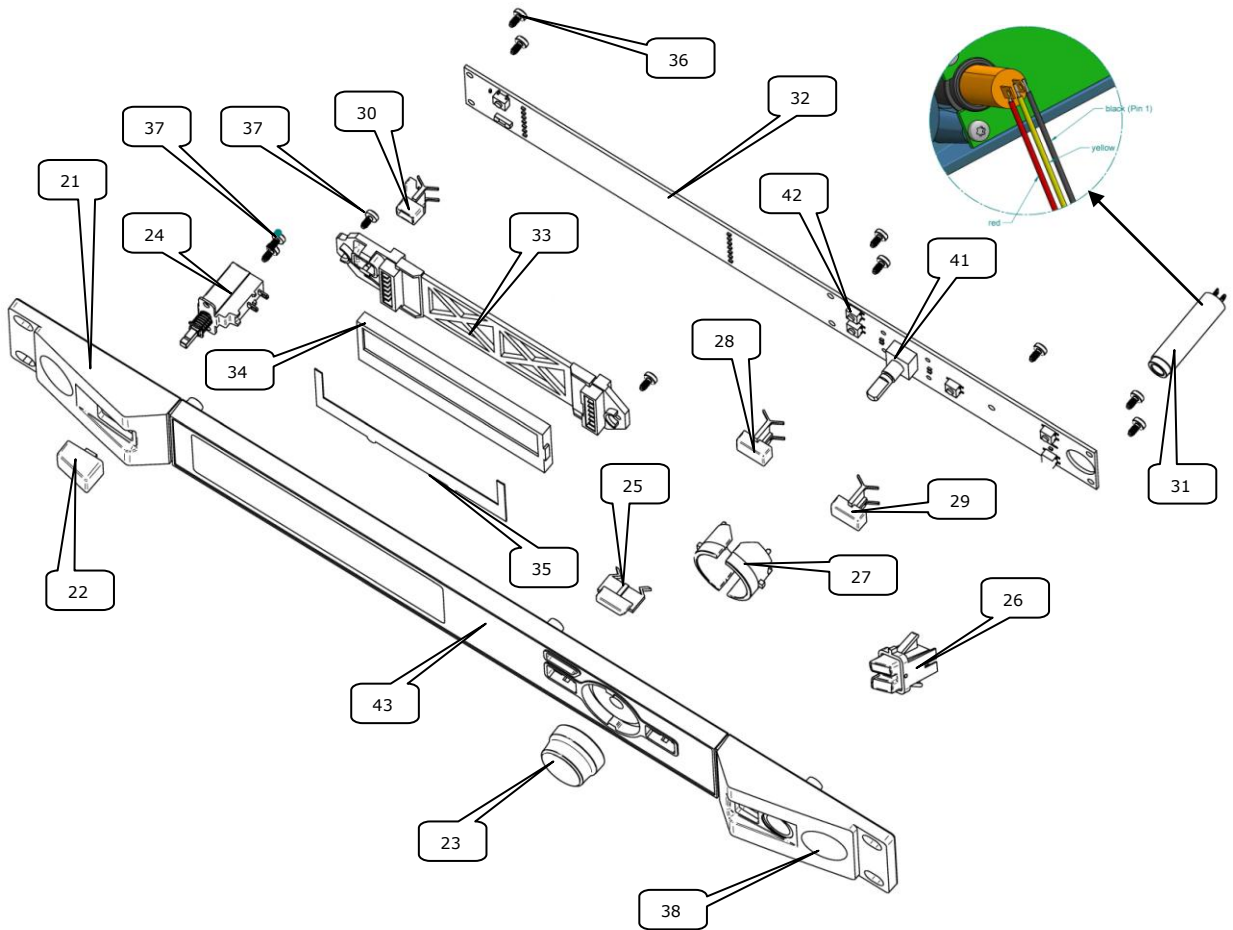

## DSR 800 Parts list / Stückliste

Description	Pos.	Part number Bestellnummer	Quantity Stück	Bezeichnung
Housing, upper	1	3155Z11020	1	Gehäuseoberteil
Housing, bottom	2	3155M10020	1	Gehäuseunterteil
Power supply unit	3	5048351	1	Netzteil
IEC power socket	4	0017E15070	1	IEC Einbaustecker
Isolation plate	5	3155Z45010	2	Isolationplatte
Cable assy.	6	0110E03220	1	Kabel
DSP Main board	7	5048392	1	DSP Hauptprint
RF board Band 1	8	3155M05030	1	HF Print Band 1
RF board Band 2	8	3155M05040	1	HF Print Band 2
Data cable	9	0016E18240	1	Datenkabel
Data cable	10	0016E18230	1	Datenkabel
Screw EJOT PT DG 40x8	11	0099N40040	4	Schraube EJOT PT DG 40x8
Screw EJOT PT KB 30x8	12	0099N30080	6	Schraube EJOT PT KB 30x8
Screw M3x8	13	7985D30110	4	Schraube M3x8
Screw M3x12	14	7985D30120	6	Schraube M3x8
Screw B2,9x6,5	15	7981D29070	7	Schraube B2,9x6,5
Lockwasher	16	0128D03000	7	Sicherungsscheibe
Screw EJOT K+/B 30x8	17	9999N07810	2	Schraube EJOT PT DG 30x8
Lockwasher	18	9999N06050	3	Sicherungsscheibe
BNC nut	19	2841Z10010	3	BNC Mutter
Dante board	20	5044951	1	Dante Print
Front panel	21	3155M20030	1	Frontplatte
"Power" button	22	3155Z23010	1	"Power" Knopf
Jog-button	23	3155M21010	1	Jog-Knopf
Power switch	24	0040E06460	1	Hauptschalter
"Back" button	25	3155Z26010	1	"Back" Knopf
Rocker-switch assy.	26	3155M22010	1	Rocker-Schalter assy.
Light guide	27	3155Z27010	2	Lichtleiter
"Channel" button, left	28	3155Z25010	1	"Channel" Knopf, links
"Channel" button, right	29	3155Z25020	1	"Channel" Knopf, rechts
"FX" button	30	3155M23010	1	"FX" Knopf
Headphone socket 6,3mm	31	0017E03600	1	Kopfhörerbuchse 6,3mm
Front board	32	3155M03010	1	Front Print
Display holder	33	3155M24010	1	Displayhalter
LCD display	34	5047954	1	LCD Display
Display gasket	35	3155Z33010	1	Displaydichtung
Screw EJOT P+/B 30x8	36	0099N30180	7	Schraube EJOT PT DG 30x8
Screw EJOT PT DG 30x6	37	0099N30150	4	Schraube EJOT PT DG 30x6
Cover part	38	3155Z36010	2	Abdeckung
Grommet	40	7261N30040	2	Tülle
Jog dial switch	41	0040E06500	1	Dreh-Drück-Schalter
Push switch	42	9040E00160	6	Drückschalter
Self-adhesive front foil	43	3155Z30040	1	Selbstklebende Frontfolie
Antenna Bd1 (long)	-	9999N07440	2	Antenne Bd1 (lang)
Antenna Bd2 (short)	-	9999N07450	2	Antenne Bd2 (kurz)
Mains cable EU	-	0110E03160	1	Netzkabel EU
Mains cable US	-	0110E03170	1	Netzkabel US

**Important!**

Always make a firmware update after DSP, RF, or Display board has been replaced.  
For ordering the DSR 800 front board we need following information:

- Preset programming: Bd1, Bd2, BD1 UK..... (please see table on the next page)

Frequency band / Frequenzband								
Preset →	BD1	BD1 NZ	BD1 AU	BD1 UK	B2	BD2 DE		
Front board 3155M03010	x	x	x	x	x	x		
Device sticker	5048331	5048334	5048332	5048333	5048335	5048336		

CU 800 3158Z00050

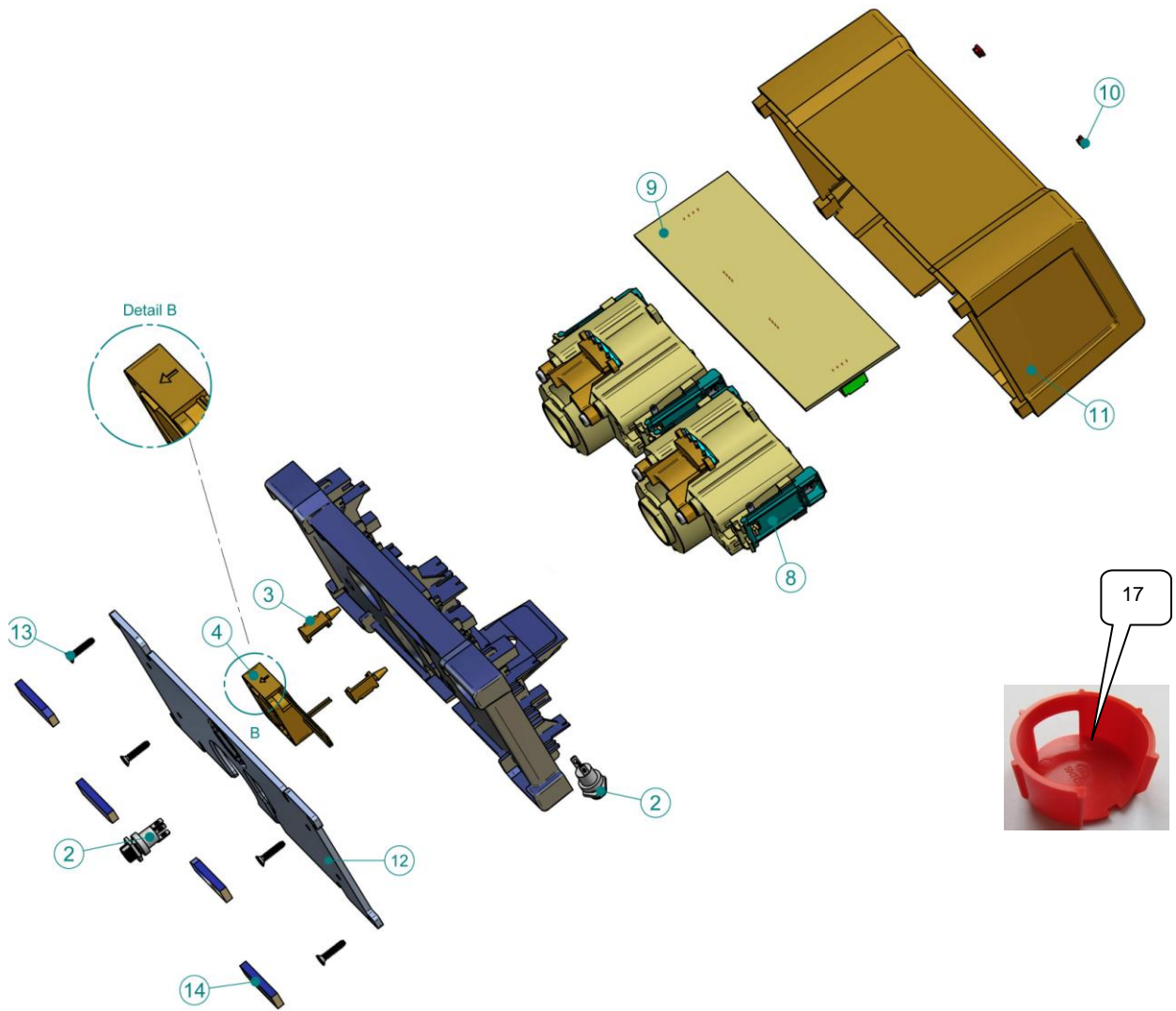

Wiring / Verkabelung

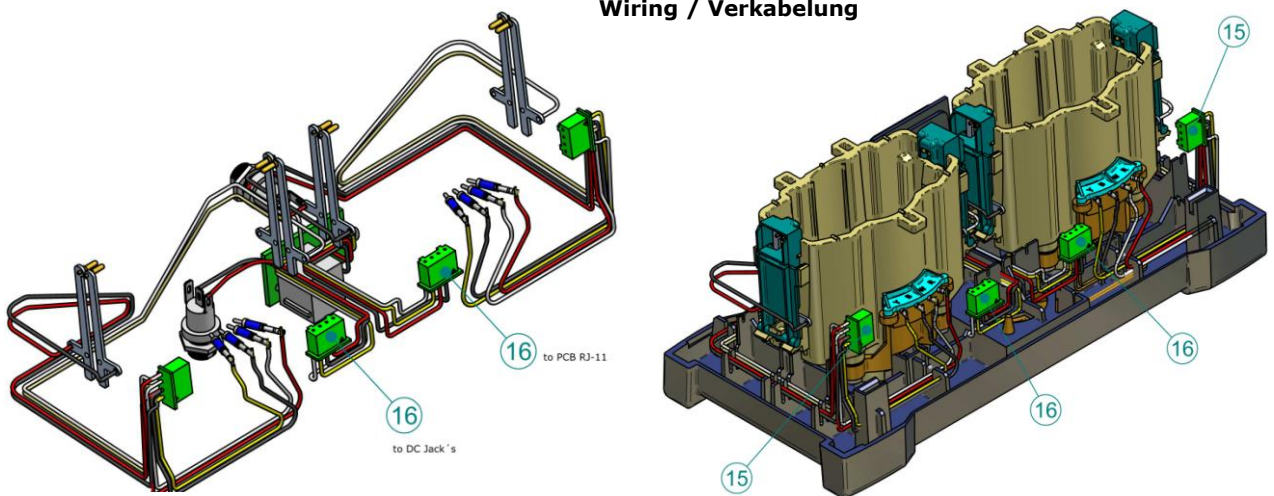

**CU 800 Parts list / Stückliste**

<i>Description</i>	<i>Pos.</i>	<i>Part number Bestellnummer</i>	<i>Quantity Stück</i>	<i>Bezeichnung</i>
Housing bottom	1	3158Z12010	1	Gehäuseunterteil
DC-Jack socket	2	0016E03760	2	DC-Buchse
Fan holder	3	3158Z23010	2	Lüfterhalter
Fan	4	0027E00710	1	Lüfter
Insert part assy.	8	3158M11010	2	Einsteckteil
Main board	9	3158M01010	1	Hauptprint
Light guide	10	3158Z13010	2	Lichtleiter
Housing top	11	3158Z10020	1	Gehäuseoberteil
Metall plate	12	3158Z21010	1	Metallplatte
Screw EJOT PT KB 30x12	13	0099N30170	4	Schraube EJOT PT KB 30x12
Housing foot	14	3158Z24010	4	Gehäusefuß
Cable assy.	15	3158M15010	2	Kabel kompl.
Cable assy.	16	3158M16010	2	Kabel kompl.
Rechargeable battery, packing unit 4 pcs.	-	0026E00270	4	Akkus, Verpackungseinheit 4Stk.
Power supply 12V/2A EU,UK,US,AU	-	7801H00110	1	Netzteil 12V/2A EU,UK,US,AU
CU Adapter DHT800	17	5047432	1	Adapter für CU700/800