

ATS Series Microphone Table Stand Accessory

OVERVIEW

The ATS1, ATS1LX and ATS1LP are the industry's only programmable, shock absorbent table stands with an LED indicator that does not require external power supplies, eliminating the added expense and complication associated with installation and wiring. The LED indicator and audio switching circuitry operate on the same phantom power source supplied to the microphone. The result is simplified installation and reliable operation. The base has programmable functions that are changed with a simple, intuitive dip switch which can be set to operate in Toggle On, Toggle Off, Momentary Talk and Momentary Mute modes. Also supplied within the base is a Low Cut Filter offering additional protection from bass frequencies that may cause rumble or hum. The ATS1LX and ATS1LP can be further programmed to operate seamlessly with automated teleconferencing and switch systems in external logic control mode.

The ATS is manufactured with a precision die cast zinc alloy base, durable black E-coat finish, LED indicators and a noise free mechanical switch.

MODEL VARIATIONS

ATS10 - Table stand with latching on/off switch

ATS1 - Heavy-duty shock absorbent table stand with XLR connector, programmable switch (on/off, talk/mute) and choice of two connector versions:

- **ATS1LP** - 5-pin terminal connector located inside the base
- **ATS1LX** - 5-pin XLR output connector located at the back of the base

OPTIONAL MICROPHONES

ADX Series - ADX12, ADX18

MG Series - MG12HC, MG15HC, MG18HC

MGN Series - MGN6, MGN12, MGN29

MicroPod - MicroPod6, MicroPod6HC, MicroPod12, MicroPod12HC, MicroPod18, MicroPod18HC, MicroPod6S, MicroPod6WS



FEATURES

- Heavy duty die cast base provides stability
- Shock mount design limits touch noise and vibration
- Four programmable talk-mute functions
- Local remote control function settings
- Seamless integration with automated mixers (ATS1LX & ATS1LP)
- Designed, assembled & tested in the USA
- 1 year warranty

APPLICATIONS

- Podium
- Lectern
- Video conferences
- Classrooms
- Courtrooms
- Boardrooms



ATS WITH OPTIONAL MIC



CLOSE UP



3-PIN XLRm OUTPUT



BOTTOM

ATS

SPECIFICATIONS

	ATS10	ATS1	ATS1LP	ATS1LX
Mic Input Connector	3-pin XLRf			
Base Output Connector	3-pin XLRm	3-pin XLRm	5-pin Terminal Block	5-pin XLRm
Switch	Latching on/off	Programmable on/off, talk/mute	Programmable with remote capabilities	Programmable with remote capabilities
Off (mute) attenuation	45dB minimum			
Power Requirements	11-52 V phantom DC 2mA typical	36-52 V phantom DC 2mA typical	36-52 V phantom DC 2mA typical	36-52 V phantom DC 2mA typical
Finish	Matte Black			
Length	160 mm / 6.9 in			
Width	124 mm / 5.9 in			
Height	45 mm / 1.8 in			
Weight	1.4 kg / 3 lbs			
Closure I/O voltage	-	-	-0.5 to 30 V	-0.5 to 30 V
Closure through current	-	-	200 mA	200 mA
On resistance	-	-	>10 ohms	>10 ohms
I/O leakage current	-	-	1uA	1uA
LED input	-	-	Active when low (0.4 V DC) TTL compatible	Active when low (0.4 V DC) TTL compatible

DIMENSIONS (mm)

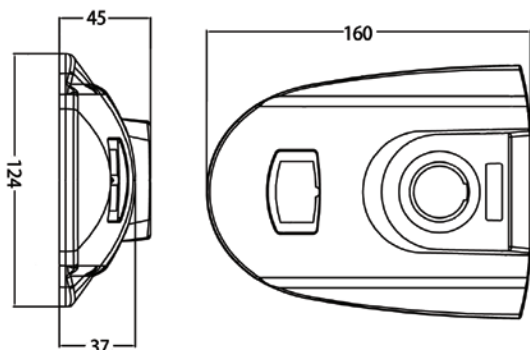

SWITCH SETTINGS

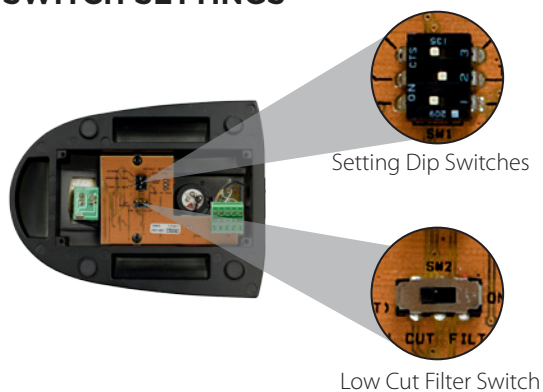

OPERATION

Connecting the Gooseneck Microphone

Align the connector of the microphone to the XLR pins on top of the base. Gently push down until the connectors “click” into place.

Important: The microphones will require phantom power to operate. This may be supplied to the microphone from either the mixing console or a phantom power supply.

Setting Dip Switch

Low Cut Filter: Inside the base, locate the switch on the PCB labeled “Low Cut Filter.” The filter provides protection from bass frequencies that may cause rumble, hum, or vibration by eliminating frequencies <100 Hz. To engage, push the dip switch to the “on” position.

Removing the Microphone

Press the release tab on the top of the base to remove the microphone.

Connecting Audio and Logic

Use a balanced microphone cable and connect into the back side of the ATS base until it “clicks” into place. To disconnect, press the tab on the microphone cable XLRf connector and remove from base.

Configuration

Momentary Mute: Mic is on; switch is pressed and held to mute.

Momentary Talk: Mic is off; switch is pressed and held to talk.

Toggle Off: Mic is on; switch is pressed to turn the mic off and on

Toggle On: Mic is off; switch is pressed to turn the mic on and off

Dip Switch Setting



PRODUCT REGISTRATION

Please register your product online at www.audixusa.com/docs_12/about/product_registration.shtml.

SERVICE AND WARRANTY

The microphone stands are under warranty for a period of 1 year to be free of defects in material and workmanship. In the event of a product failure due to materials or workmanship, Audix will repair or replace said product at no charge with proof of purchase. Audix does not pay or reimburse shipping costs for warranty repairs or returns. The warranty excludes any causes other than manufacturing defects, such as normal wear, abuse, environmental damage, shipping damage or failure to use or maintain the product per the supplied instructions. No Implied Warranties: All implied warranties, including but not limited to implied warranties of merchantability and fitness for a particular purpose are hereby excluded. The liability of Audix, if any, for damages relating to allegedly defective products shall be limited to the actual price paid by Dealer for such products and shall in no event include incidental or consequential damages of any kind. Should your microphone fail in any way, please contact the Audix Service department at 503.682.6933. A Return Authorization is required before returning any product. OTHER THAN THIS WARRANTY, AUDIX MAKES NO WARRANTIES, EXPRESS OR IMPLIED, WITH RESPECT TO THE PRODUCTS, THE USE OF THE PRODUCTS, THE PERFORMANCE OF THE PRODUCTS. AUDIX SHALL NOT BE LIABLE FOR SPECIAL, INCIDENTAL, CONSEQUENTIAL, INDIRECT OR SIMILAR DAMAGES ARISING FROM OR BASED ON THE SALE, USE, STORAGE OR DISPOSAL OF THE PRODUCTS, AUDIX'S SERVICE WORK, BREACH OF WARRANTY, BREACH OF CONTRACT, NEGLIGENCE, OR ANY OTHER THEORY OF LIABILITY, EVEN IF AUDIX HAS BEEN ADVISED OF THE POSSIBILITY OF SUCH DAMAGES.

ALL SPECIFICATIONS SUBJECT TO CHANGE WITHOUT NOTICE.



www.audixusa.com
503.682.6933 Fax: 503.682.7114
Audix Corporation 9400 SW Barber St. Wilsonville, OR 97070

AUDIX
ver 2.0 07-15