



KMT18 I

USER GUIDE English

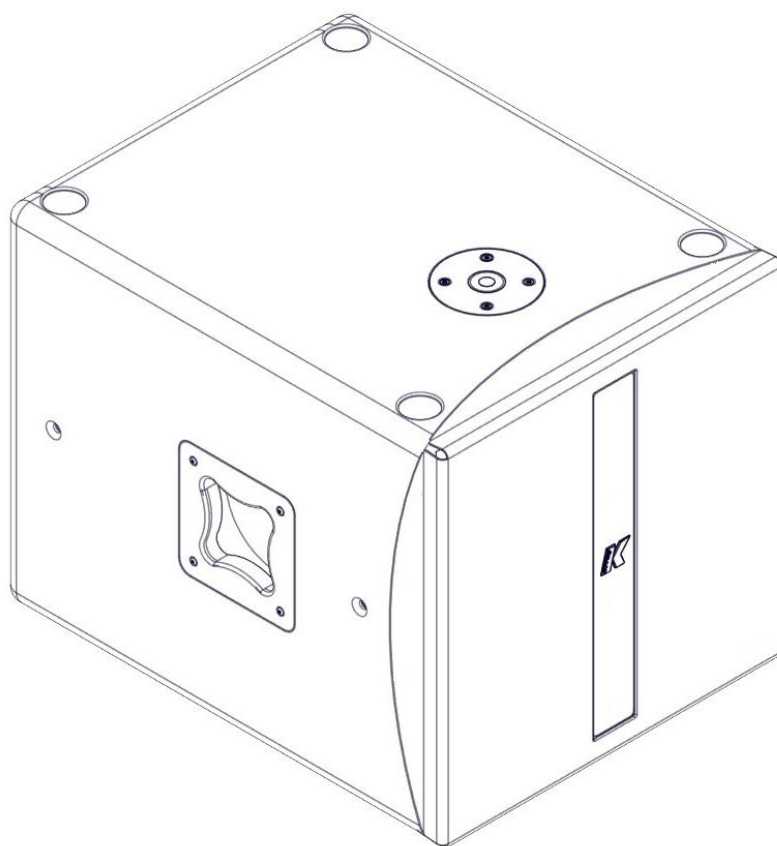

TABLE OF CONTENTS

SYMBOLS	3
1. INTRODUCTION	4
2. KEY FEATURES	4
3. APPLICATIONS	4
4. SAFETY INFORMATION	5
5. UNPACKING	7
6. PHYSICAL	8
7. AMPLIFIER	9
7.1 AC POWER	9
7.2 VOLTAGE REQUIREMENT	9
7.3 CURRENT REQUIREMENT	9
7.4 PROTECTION CIRCUITRY	10
7.5 REAR PANEL	10
7.6 RS485 NETWORK	12
8. TOUCH SCREEN FUNCTIONS	13
9. HANGING POINTS	16
10. CONFIGURATIONS	17
11. SERVICE	18
12. TECHNICAL SPECIFICATIONS	19

SYMBOLS



K-array declares that this device is in compliance with applicable CE standards and regulations. Before putting the device into operation, please observe the respective country-specific regulations!



WEEE
Please dispose of this product at the end of its operational lifetime by bringing it to your local collection point or recycling center for such equipment.



This symbol alerts the user to the presence of recommendations about the product's use and maintenance.



Warning! Dangerous voltages: RISK of electric shock.
Terminals marked with this symbol are HAZARDOUS LIVE and the external wiring connected to these terminals requires installation by a qualified professional or the use of ready-made leads or cords.



This symbol alerts the user to the presence of recommendations about product's use and maintenance.



This device complies with Restriction of Hazardous Substances Directive.

1. INTRODUCTION

The K-array KMT18 I is a complete audio system, featuring a 18" powered subwoofer, programmable on-board DSP, multiple analog and digital inputs and outputs for creating a broad range of speaker configurations.

The KMT18 I features an integrated touch screen, providing intuitive control over the main DSP functions: input/output levels, signal routing, offset delays for subwoofer and speaker output (up to 10 ms, each) and overall system delay (up to 330 ms). All DSP functions, including EQ, can also be remote controlled via software over USB or RS485 (3-pin XLR).

The KMT series provides two balanced analog line level inputs and a two-channel AES/EBU digital input. An integrated class D amplifier delivers 2 x 1000 W at 8Ω, with a max THD of 1% (EIAJ test @ 1kHz). The KMT18 I features multiple analog and digital outputs, including a Speakon output to connect a wide array of passive speakers including mid-high modules (KK52, KK102) or additional passive subwoofers (KMT18P). To optimize performance, the on-board DSP includes presets to drive K-array speakers.

The KMT series' unique four-corner port configuration provides symmetrical back loading to the speakers, for extended bass response with very low distortion. The port configuration also provides incredible structural strength to the cabinet, despite its light weight. Pocket handles and an M20 thread mount position for attaching mid-high speakers makes it convenient to use and ideal for medium throw applications in theaters, concert halls, and Audio/Video installations.

All KMT components are designed by K-array and custom-made under K-array's quality control system.

2. KEY FEATURES

- Unique performance-to-size ratio
- Direct radiating, long excursion driver
- Ultra fast set-up and dismantling system
- Fitted with integrated handles and castors
- Analog and digital AES/EBU inputs
- Remote software control over USB and RS485
- Optimized for use with KK52/KK102 and KMT18P

3. APPLICATIONS

- Theatrical sound reinforcement
- Concert halls, clubs, houses of worship
- Portable and installed audio-visual systems
- Cinema and special effects

4. SAFETY INFORMATION

Read these instructions - Keep these instructions - Heed all warnings



Warning. Failure to follow these safety instructions could result in fire, shock or other injury or damage to the device or other property.



This symbol alerts the user to the presence of recommendations about the product's use and maintenance.



The lightning flash with arrowhead symbol within an equilateral triangle is intended to alert the user to the presence of not isolated, dangerous voltage within the product enclosure that may be of magnitude to constitute a risk of electrical shock.

IMPORTANT SAFETY INSTRUCTIONS

- Read these instructions.
- Keep this instructions.
- Heed all warnings.
- Follow all instructions.
- Do not use this apparatus near water.
- Clean only with dry cloth.
- Do not block any ventilation openings. Install in accordance with the manufacturer's instructions.
- Do not install near any heat sources such as radiators, heat registers, stoves, or other apparatus (including amplifiers) that produce heat.
- Do not defeat the safety purpose of the polarized or grounding-type plug. A polarized plug has two blades with one wider than the other. A grounding type plug has two blades and a third grounding prong. The wide blade or the third prong are provided for your safety. If the provided plug does not fit into your outlet, consult an electrician for replacement of the obsolete outlet.
- Protect the power cord from being walked on or pinched particularly at plugs, convenience receptacles, and the point where they exit from the apparatus.
- Only use attachments/accessories specified by the manufacturer.
- Use only with the cart, stand, tripod, bracket, or table specified by the manufacturer, or sold with the apparatus.



- When a cart is used, use caution when moving the cart/apparatus combination to avoid injury from tip-over.

- Unplug this apparatus during lightning storms or when unused for long periods of time.
- Refer all servicing to qualified service personnel. Servicing is required when the apparatus has been damaged in any way, such as power-supply cord or plug is damaged, liquid has been spilled or objects have fallen into the apparatus, the apparatus has been exposed to rain or moisture, does not operate normally, or has been dropped.

**WARNING**

- Since the device is a CLASS I apparatus, it must be only connected to an AC **three-wire grounding outlet**. If your outlet isn't grounded, contact a licensed electrician to replace it with a property grounded outlet.
- To reduce the **risk of electric shock**, unplug the AC mains connector before installing audio cable. Reconnect the power cord only after making all signal connections. Do not use the product if the power cord is broken or frayed. Protect the power cord from being walked upon or pinched.
- To completely disconnect this apparatus from the AC mains, disconnect the power supply cord plug from the AC receptacle.
- **Avoiding hearing damage**. Professional loudspeakers are capable of producing extremely high sound levels and should be used carefully. Never stand close to loudspeakers driven at high volume. Set the volume to a safe level. You can adapt over time to a higher volume of sound that may sound normal but can be damaging to your hearing. Hearing loss get worse every time you're exposed to a sound level of 90 dB or over for an extended period of time. If you experience ringing in your ears or muffled speech, stop listening and have your hearing checked. The louder the volume, the less time is required before your hearing could be affected.
- **Voltage requirement**. Make sure that the supplied voltage stays within the specified range. Verify that your mains connection satisfies the power ratings of the device.
- Only connect the power supply to an appropriate power outlet
- Do not install the amplifier in wet or humid locations without using weather protection.
- **TO REDUCE THE RISK OF FIRE OR ELECTRIC SHOCK**, do not expose this apparatus to rain or moisture and objects filled with liquids, such as vases, should not be placed on this apparatus.
- The main plug of the power supply cord shall remain readily accessible.

**CAUTION**

- **Choking Hazards**. This device contains small parts, which may present a choking hazard to small children. Keep the device and its accessories away from small children.
- It is important that loudspeaker systems are used in a safe manner.
- **Do not make repairs yourself**. Caution, risk of electric shock. Do not open the device, it contains potentially hazardous voltage. Never attempt to disassemble, repair or modify the system yourself. Disassembling the unit may cause damage that is not covered under the warranty. The device contains no user-serviceable parts. **Repairs should only be performed by factory trained service personnel**. Do not plug the power cord in if you suspect that your device needs service or repair.
- **Sound distortion**. Do not operate speakers for an extended period of time with sound distortion. This is an indication of malfunction, which in turn can generate heat and result in a fire.
- **Cooling**. During the use, it is normal for the device to get warm. The exterior of the device functions as a cooling surface that transfers heat from inside the unit to the cooler air outside. The device should be placed so that its location does not interfere with its proper cooling. For example, the device shouldn't be placed next to surfaces that can interfere with the properly cooling of the rear panel's radiators. When operating, the device should not be cover with additional protections.

- **Temperature.** Operate the device in a place where the temperature is between -20°C and 35°C (-4°F to 95° F). Avoid dramatic changes in temperature or humidity when using it, as condensation may form on or within the device.
- Take care not to spill any food or liquid through the device's grill. Do not attempt to dry the device with an external heat source, such as a hair dryer.
- **Carrying, handling and installing the device.** The device contains sensitive components. Do not drop, disassemble, open, crush, bend, deform, puncture, shred, incinerate, paint, or insert foreign objects into it. If your device has been dropped or damaged unplug the power cable immediately.
- **Set up.** Set up your device on a stable retaining horizontal surface. If combined or mechanically connected with other products, always verify the stability of the resulted system. Install the unit only in a location that can structurally support the weight of the unit, far away from people who can interfere with the stability of the system. In case of outdoor installation, protect the device from rain and moisture. Assure that the wind does not interfere with the system's stability, taking extra securities like chains, weights, ropes or any other certified anchoring systems. Doing otherwise may result in the unit falling down, causing personal injury or property damage or even death. The system should only be suspended by qualified personnel following safe rigging practices. Secure fixings to the building structure are vital. To clarify any doubt you may have, seek help from architects, structural engineers or other specialists.
- This audio system is not intended for use in the operation of nuclear facilities, aircraft navigation or communication systems, air traffic control systems, or for any other uses where the failure of the audio system could lead to death, personal injury, or sever environmental damage.

5. UNPACKING

Each K-array speaker is built to the highest standard and thoroughly inspected before leaving the factory. Upon arrival, carefully inspect the shipping carton, then examine and test your new amplifier. If you find any damage, immediately notify the shipping company. Only the consignee may institute a claim procedure regarding the system's electronic equipment.

6. PHYSICAL

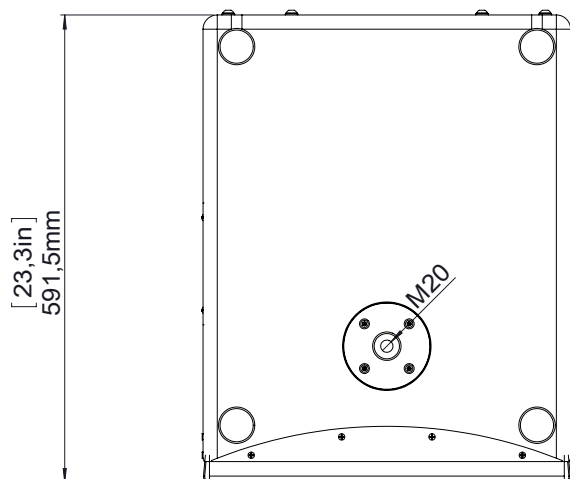
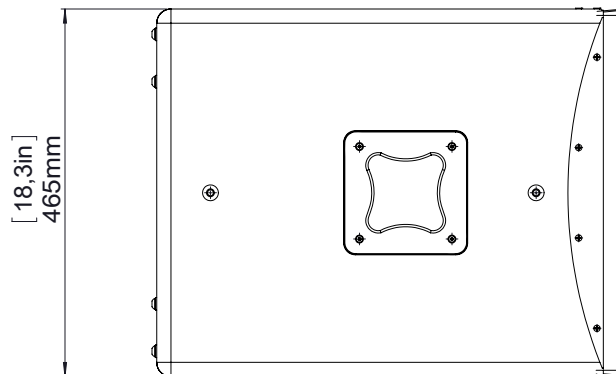
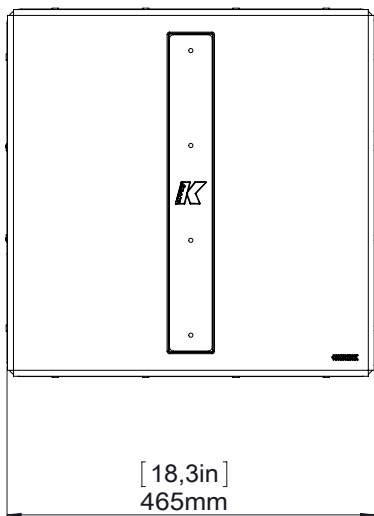

Weight
24.6 kg (54.2 lbs)

7. AMPLIFIER

7.1 AC POWER

The amplifier module and any audio equipment connected to it (mixing consoles, processors, etc.) must be properly connected to the AC power distribution, preserving AC line polarity. Every grounding point must be connected to a single node or common point using the same cable gauge as the neutral and line cable. Bad grounding connections between speakers and the rest of the equipment may produce noise, hum or serious damage to the input/output stages in the system's electronic equipment.



Before applying AC to any K-array self-powered speaker, be sure that the voltage potential difference between neutral and earth ground is less than 5 VAC.



7.2 VOLTAGE REQUIREMENT

The auto-range power supply feature allows the amp unit to operate safely and with no audio discontinuity when the AC voltage stays within a nominal range of 100 - 240 V (operating range 85 - 265 V) at 50 to 60 Hz. Please verify that your AC main connections are capable of satisfying the power rating for the device.



CAUTION. Do not connect the system to AC power mains exceeding 265 V. Doing so will cause significant damage to the device and create serious risk for users!



7.3 CURRENT REQUIREMENT

The amplifier presents a dynamic load to the AC mains, drawing additional current as operating levels increase. Different cables and circuit breakers heat up at varying rates, so it is essential to understand current ratings and how they correspond to circuit breaker and cable specifications. Maximum continuous RMS current - measured over a period of at least ten seconds - is used to calculate the temperature increase in cables, which drives the proper size and gauge cable and rating for slow-reacting thermal breakers. Maximum burst RMS current - measured over a period of approximately one second - is used to select the rating for fast reacting magnetic breakers.

For best performance, voltage drops should not exceed 10% at 100 V or 10% at 230 V. The minimum electrical service amperage required by a K-array loudspeakers system is the sum of their maximum continuous RMS current. K-array recommends allowing an additional 30% above the minimum amperage to prevent peak voltage drops at the service entry.

7.4 PROTECTION CIRCUITRY

Both the Power supply and the amplifier sections are equipped with several protection circuits. Power supply protections aim to isolate a faulty section in electrical power system from the rest of the device in order to prevent the propagation of the fault and limit device damages. They comprise overcurrent, overvoltage and thermal protections.

Amplifier protections are triggered by audio signal current and voltage – by comparing input and output – and NTC (Negative Temperature Coefficient) thermistors. A Peak Current Shut Down and a Temperature Protection Limiter protect the output stage.

High frequency stationary signals, like steady sinusoidal signals – improperly referred as continuous or permanent signals – with high amplitude tend to stress the amplifier section of the modules as well as the loudspeakers voice coils. When a high frequency stationary loud signal is feed into the amplifier a dedicated Limiter limits its mean current depending on its level and frequency.

7.5 REAR PANEL

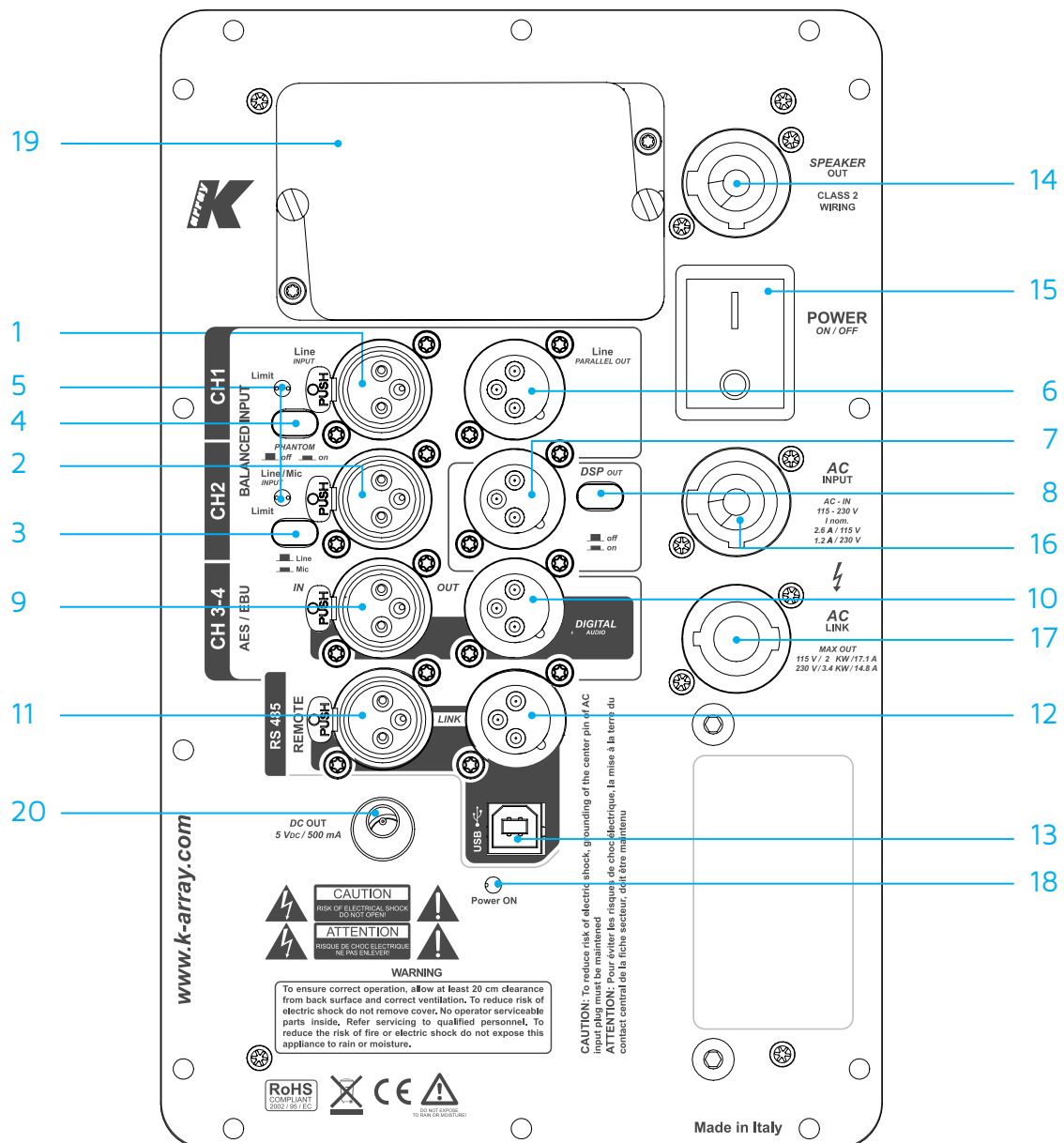

- 1) CH1 Line Input. XLR line level input with +4 dBu sensitivity.
- 2) CH2 Mic/Line Input. XLR input, with selectable sensitivity for Mic (-30 dBu) or Line (+4 dBu).
- 3) Mic/Line switch. Selects CH2 input sensitivity for Mic (-30 dBu) or Line (+4 dBu) level.
- 4) Phantom Power switch. Turns phantom power (48V) on/off on CH2 input.
- 5) Limiting LEDs. Independent LEDs for the CH1 and CH2 inputs, which blink when the optical limiter engages to protect the corresponding preamp circuit. Limiter threshold is +5 dBu.
- 6) CH1 Parallel Line Out. XLR parallel output providing a direct signal from the CH1 Line Input. This output cannot be processed or controlled via the K-Framework software.
- 7) DSP Out. When the DSP Out switch is not pressed (off), this connector provides a direct signal from the CH2 input. At the moment this connector doesn't output any signal if the DSP Out switch is pressed (on). This function will be useful for future applications.
- 8) DSP Out Switch. See point 7.
- 9) AES/EBU Digital Input. XLR input connector for two-channel AES/EBU digital audio, accepting sample rates up to 96 kHz.
- 10) AES/EBU Digital Output. XLR output, providing two-channel digital audio from AES/EBU Input, This output cannot be processed or controlled via the K-Framework software.
- 11) REMOTE RS485 Link Input. XLR input for connecting the KMT from another RS485 device in a K-Framework network. RS485 Link Input can also be used to connect a computer running the K-Framework software (requires K-USB USB-to-RS485 adapter).
- 12) REMOTE RS485 Link Output. XLR output for connecting additional RS485 devices in a K-Framework network.
- 13) REMOTE USB Input. Connects a computer running the K-Framework software, for remote control of the KMT. Users can manage an entire network of RS485 devices with one PC connected via USB.
- 14) Speaker Out. Powered Speakon output, used to drive passive speakers, like a mid-high module or a passive subwoofer.
- 15) Power switch. Turns the KMT system on and off.
- 16) AC Input. PowerCon input for AC power. See p. 11 for voltage and power requirements.
- 17) AC Link. PowerCon output for feeding AC mains power to additional K-array components with a PowerCon AC input socket.
- 18) Power On LED. Indicates the system is ON.
- 19) TOUCH SCREEN Control panel. Provides access to the main functions of the DSP on board (see Section 8)
- 20) 5 Volt Power Connector. Provides 5VDC/500mA to power e-fun accessories.

IMPORTANT NOTE

By default, the analog channel CH2 and the digital channel CH4 are not routed to any output. To activate them, go to the Matrix Page on the LCD screen (see Chapter 8).

7.6 RS485 NETWORK

The RS485 Link Input and The RS485 Link Output on the rear panel allow to create a network of K-array devices that users can manage with a PC running the K-Framework software (see the [K-Framework User Guide](#) downloadable from the k-array web site). All devices can be linked with standard XLR cable. The PC can be connected to the network either with USB cable or XLR cable (requires K-USB USB-to-RS485 adapter accessory) as shown in the diagrams below.

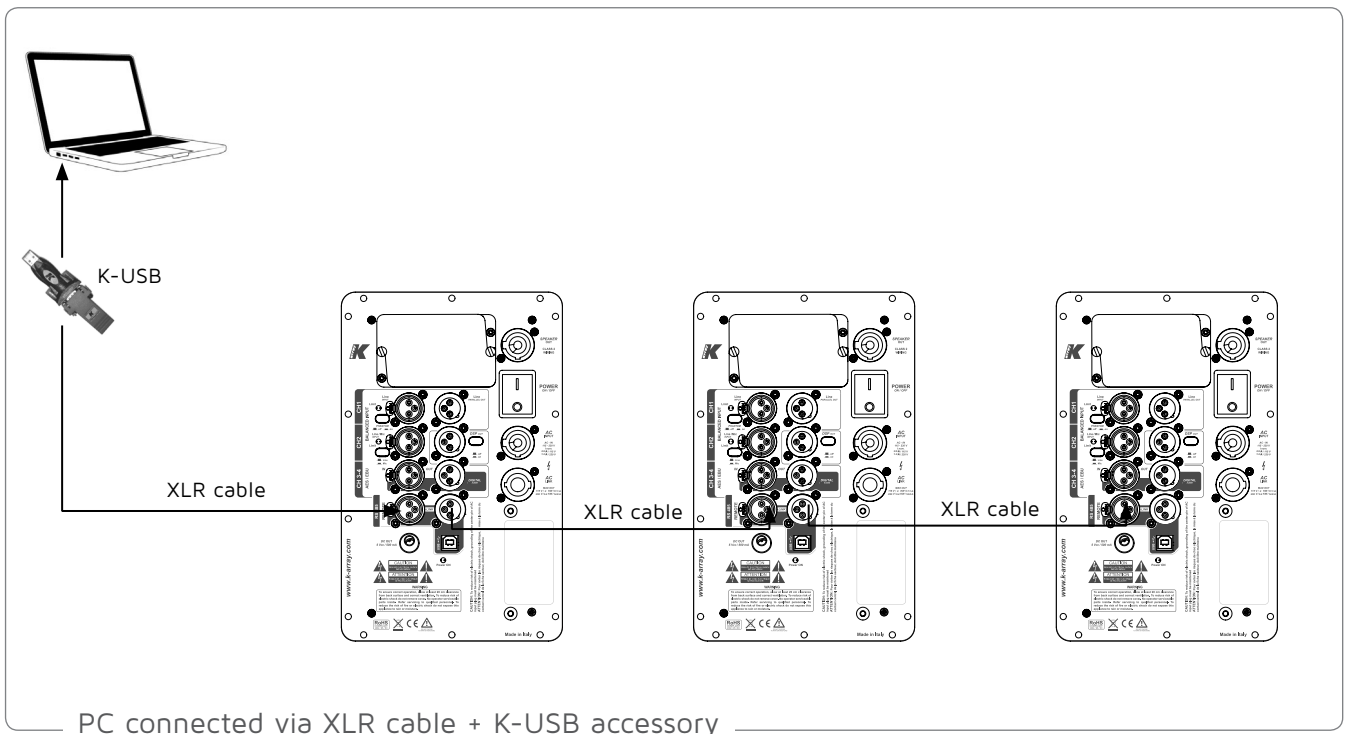
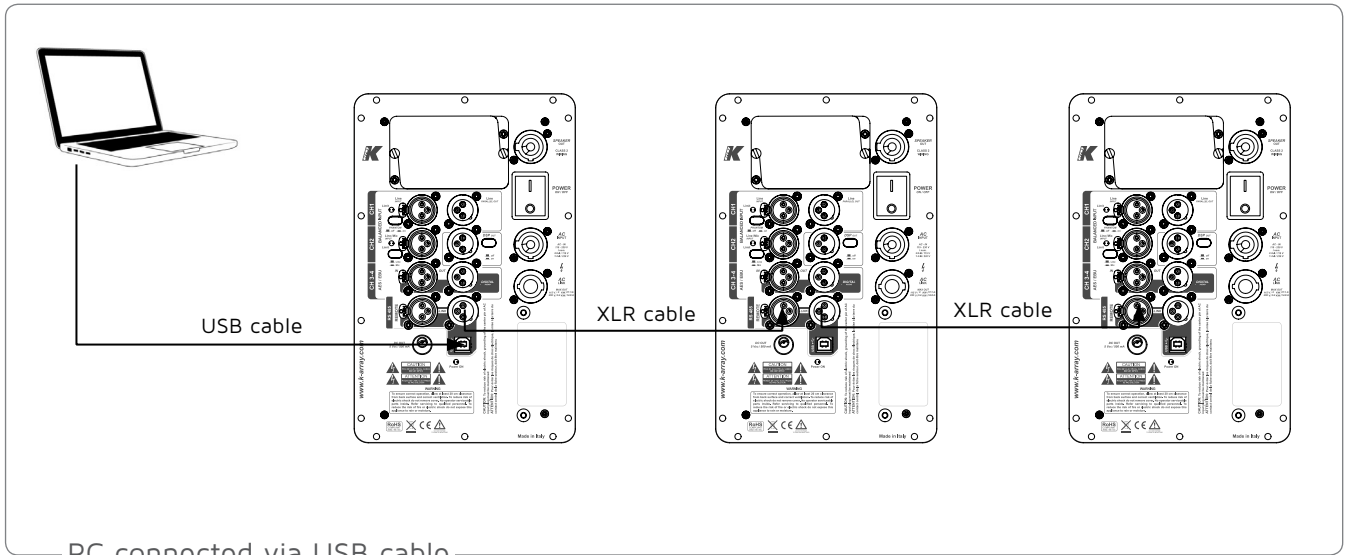

Attention. Make sure that you have set a different ID number on each device before connecting them to a PC running the K-framework. See the INFO section in Chapter 8. for details.

8. TOUCH SCREEN FUNCTIONS

The main functions of the onboard DSP can be managed with the integrated touch screen. Functions are grouped into six pages, shown as icons on the Home page.

HOME PAGE



To reach the Home page from any other page, touch the Home button.

LEVELS

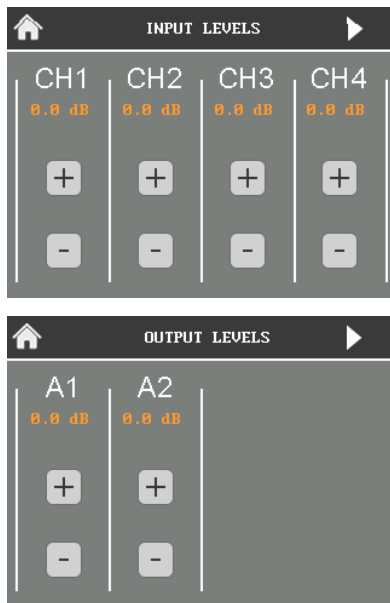

The Levels page allows users to independently manage the amplitude of the four input channels and the two output channel of the amplifier.

CH1 and CH2 are the two analog inputs, while CH3 and CH4 are the two channels of the AES/EBU digital input. A1 controls the output level sent to the subwoofer and A2 controls the output level sent to the speakers connected to the Speaker Out.

Click the arrow button on the top right corner to switch between the Input levels page and the Output levels page.

MATRIX

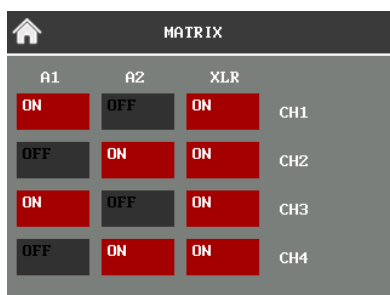

The Matrix page allows users to manage the routing of the four input channels to the subwoofer, to the speaker connected to the Speaker Out and to the XLR DSP Out. In the example shown here, the analog signal on the input channel 1 and the digital signal on the input channel 3 are sent to the subwoofer while the analog signal on the input channel 2 and the digital signal on the input channel 3 are sent to the speakers connected to the Speaker Out. All inputs channels are also summed and sent to the XLR DSP Out.

DELAY

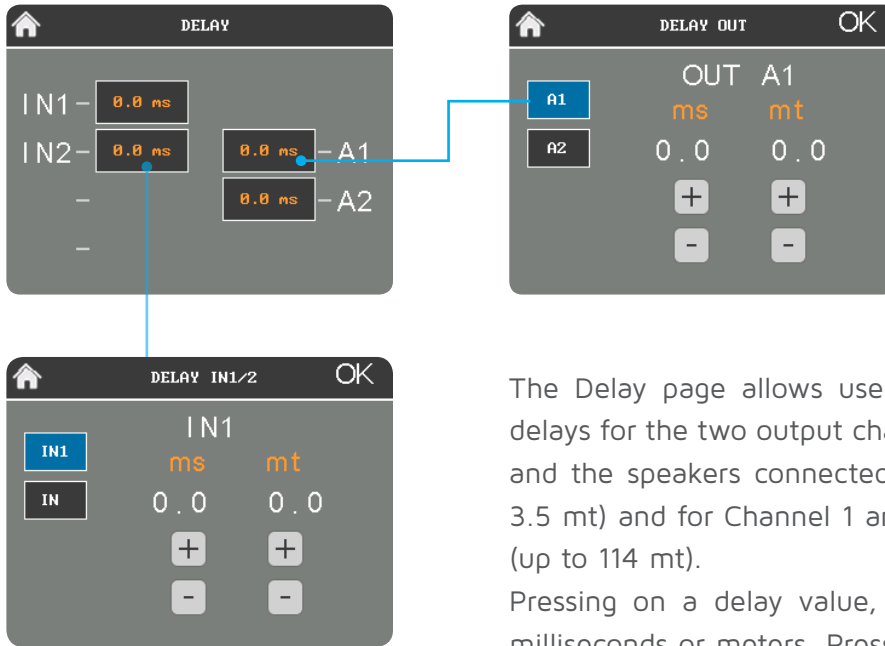

The Delay page allows users to independently set the delays for the two output channels driving the subwoofer and the speakers connected to the Speaker Out (up to 3.5 mt) and for Channel 1 and Channel 2 input channels (up to 114 mt). Pressing on a delay value, users can set the delay in milliseconds or meters. Press the OK button to return to the Delay page.

CONFIGURATION

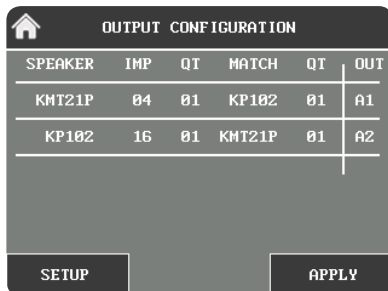

Before connecting one or more speakers to the Speaker Out, follow the instructions below.

Warning. Failure to follow these instructions could result in serious damage to the speakers connected to the amplifier!

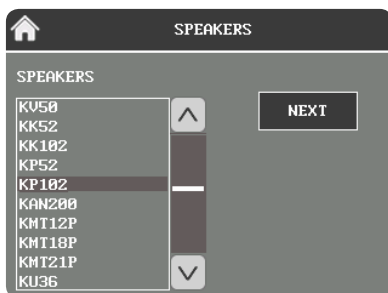

Go to the Configuration page and press the SETUP button. Insert the model and the number of speakers connected to the Speaker Out. Press the NEXT button on the top right corner. Press the APPLY button and the DSP will automatically adjust the output gain and the crossover to match the requirement for the speakers connected.



Warning. If you are using speakers with selectable impedance, pay attention to set the value indicated in the Configuration page!



PRESET

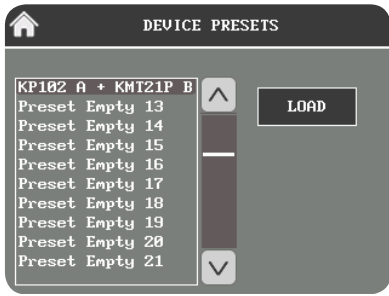

The Preset page allows users to load presets stored on-board.

INFO

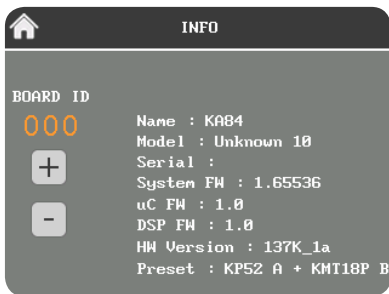

The Info page contains information about the current software and firmware, the current preset loaded and the Board ID of the device.

The Board ID is a number which identify the device when it is connected in a K-framework network (see Paragraph 7.6). Make sure that each device in the network has a different ID number.

9. HANGING POINTS

Fasten four standard M8 eyebolts to hang a KMT18 I unit from the dedicated threaded points on the chassis (see the picture). Then use appropriate steel cables sturdy enough to resist against the KMT18's weight.

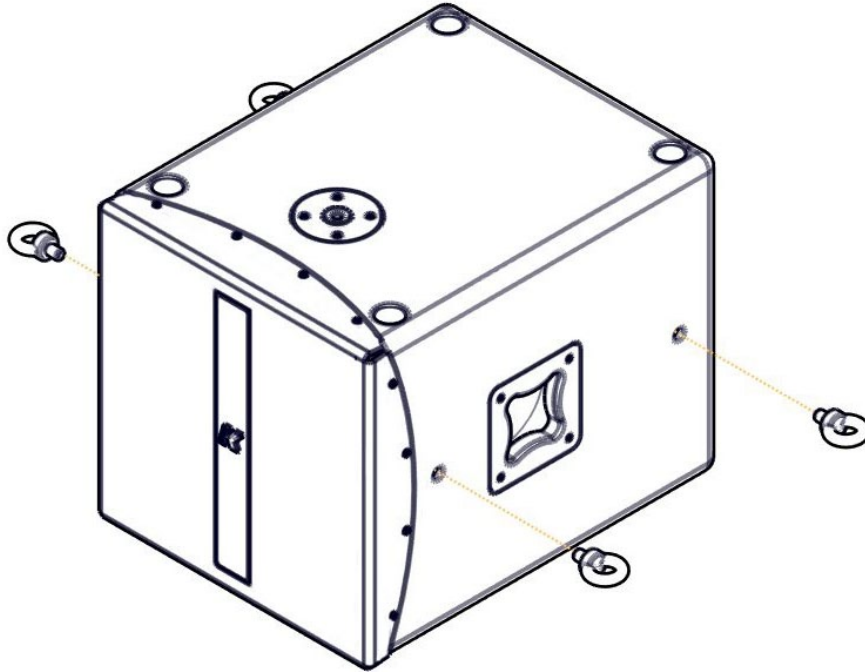

- To prevent injury, this apparatus must be securely attached to the floor/wall in accordance with the installation instructions. Tipping, shaking, or rocking the machine may cause injury or even death.
- K-array is not responsible for any rigging equipment and accessories that are not manufactured by K-array. It is the user's responsibility to ensure that the Working Load Limit (WLL) of all the additional rigging hardware accessories is greater than the total weight of the system in use.



10. CONFIGURATIONS

Mechanically the KMT18 I can perfectly match with the K-array mid-high column speakers, such as Kobras and Pythons by using the K-FOOT2 and K-JOINT2 accessories. An excellent example of the use of this combination is the K-array portable system [KR202](#).

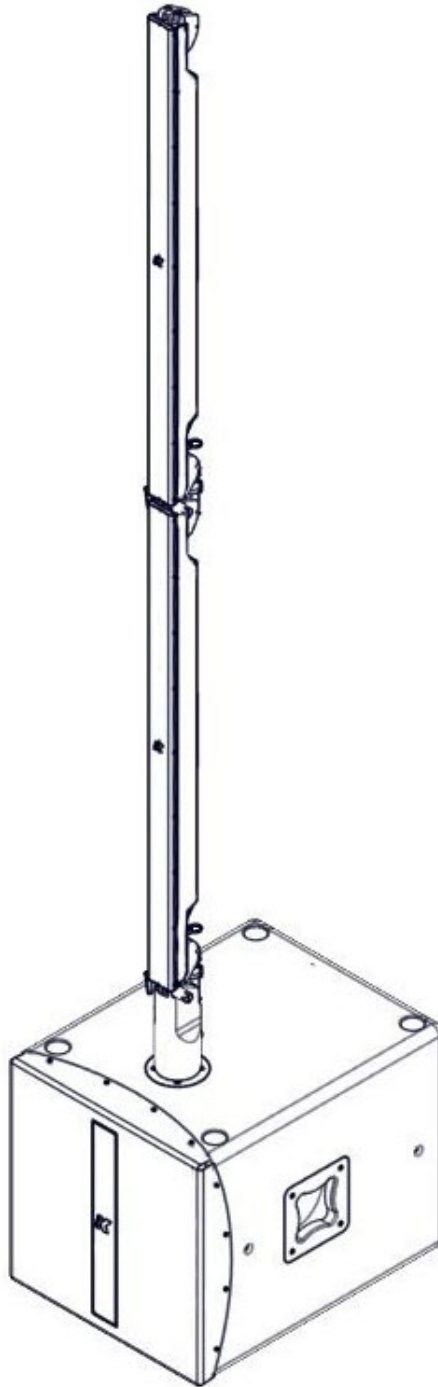

KMT18 I + 2 x KK102

11. SERVICE

To obtain service:

- 1) Contact the official K-array distributor in your country. Your local distributor will direct you to the appropriate service center.
- 2) If you are calling for service, please have the serial number(s) of the unit(s) available for reference. Ask for Customer Service, and be prepared to describe the problem clearly and completely.
- 3) If the problem cannot be resolved over the phone, you may be required to send the unit in for service. In this instance, you will be provided with an RA (Return Authorization) number which should be included on all shipping documents and correspondence regarding the repair. Shipping charges are the responsibility of the purchaser.

Any attempt to modify or replace components of the device will invalidate your warranty. Service must be performed by an authorized K-array service center.



Cleaning:

Use only a soft, dry cloth to clean the housing. Do not use any solvents, chemicals, or cleaning solutions containing alcohol, ammonia, or abrasives. Do not use any sprays near the product or allow liquids to spill into any openings.

12. TECHNICAL SPECIFICATIONS

	ACOUSTICS		AMPLIFIER
Power handling	800 W	Type	1 module class D - DSP controlled
Max power	1400 W ⁽¹⁾	Subwoofer Power Output	1000 W @ 8 Ω 1% THD + NOISE ⁽⁵⁾
Impedance	8 Ω	Speaker Power output	1000 W @ 8 Ω 1% THD + NOISE ⁽⁵⁾
Frequency range (-10 dB)	30 Hz – 150 Hz ⁽²⁾	Protections	Over Temp.(Power Limiting – Thermal Shutdown), Short Circuit/Overload Output Protection, Power Limiting, Clip Limiter/Permanent Signal Limiter, High Frequency Protection
SPL 1W/1mt	99 dB ⁽³⁾	Frequency response	20 Hz – 20 kHz (+0 -1 dB) for 1 W @ 8 Ω
Maximum SPL	130 dB (cont.) – 136 dB (peak) ⁽⁴⁾	Nominal power requirements	100 - 240 Vac ± 10% 50-60 Hz
	COVERAGE	Operating Range	85 – 265 Vac (auto-range)
Horizontal	omni	Power factor (cosφ)	>0.90 @ 4Ω full power
Vertical	omni	1/8 rated power (pink noise)@ 4Ω	300 W
	CROSSOVER		
Type	Internal DSP controlled		
Frequency	Low pass @ 150 Hz (maximum – preset dependent)		
	TRANSDUCERS		
Type	1 X 18" Neodymium magnet woofer with 3" voice coil	IP	20
	AUDIO IN/OUT		
Analog connectors	2 male + 2 female 3-pin balanced XLR	Dimensions	46.5 cm x 46.5 cm x 59.2 cm (18.3" x 18.3" x 23.3")
Digital connectors	1 male + 1 female 3-pin balanced XLR	Weight	27.6 kg (60.8 lbs)
	REMOTE CONTROL INPUT		
Connectors	1 male + 1 female XLR parallel 1 USB B Jack serial converter		

Notes for data

1. Maximum RMS applicable power for a musical signal. The reference signal is the one proposed by EIAJ standard
2. With dedicated preset;
3. Measured @4 mt then scaled @1 mt;
4. Measured with musical signal
5. EIAJ Test Standard, 1KHz, 1%THD

New materials and design are introduced into existing products without previous notice. Present systems may differ in some respects from those presented in this catalogue.