



## POWER AMPLIFIER

# PC9501N

# PC6501N

# PC4801N

# PC3301N

# PC2001N

## Owner's Manual

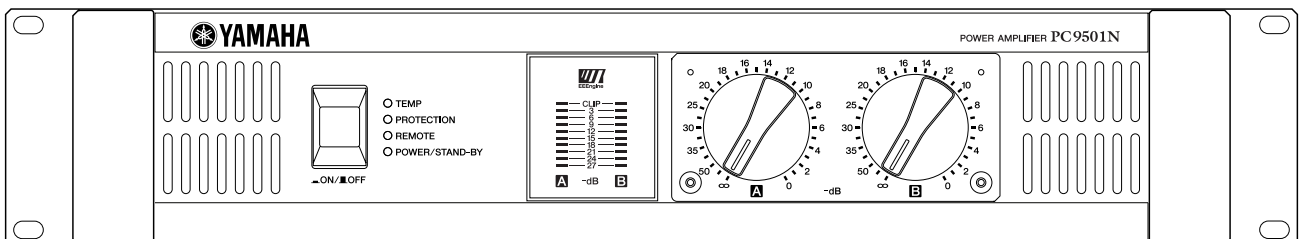

# FCC INFORMATION (U.S.A.)

## 1. IMPORTANT NOTICE: DO NOT MODIFY THIS UNIT!

This product, when installed as indicated in the instructions contained in this manual, meets FCC requirements. Modifications not expressly approved by Yamaha may void your authority, granted by the FCC, to use the product.

## 2. IMPORTANT:

When connecting this product to accessories and/or another product use only high quality shielded cables. Cable/s supplied with this product MUST be used. Follow all installation instructions. Failure to follow instructions could void your FCC authorization to use this product in the USA.

## 3. NOTE:

This product has been tested and found to comply with the requirements listed in FCC Regulations, Part 15 for Class "B" digital devices. Compliance with these requirements provides a reasonable level of assurance that your use of this product in a residential environment will not result in harmful interference with other electronic devices. This equipment generates/uses radio frequencies and, if not installed and used according to the instructions found in the users manual, may cause interference harmful to the operation of other electronic devices. Compliance with FCC regulations does

not guarantee that interference will not occur in all installations. If this product is found to be the source of interference, which can be determined by turning the unit "OFF" and "ON", please try to eliminate the problem by using one of the following measures:

Relocate either this product or the device that is being affected by the interference.

Utilize power outlets that are on different branch (circuit breaker or fuse) circuits or install AC line filter/s.

In the case of radio or TV interference, relocate/reorient the antenna. If the antenna lead-in is 300 ohm ribbon lead, change the lead-in to co-axial type cable.

If these corrective measures do not produce satisfactory results, please contact the local retailer authorized to distribute this type of product. If you can not locate the appropriate retailer, please contact Yamaha Corporation of America, Electronic Service Division, 6600 Orangethorpe Ave, Buena Park, CA90620

The above statements apply ONLY to those products distributed by Yamaha Corporation of America or its subsidiaries.

\* This applies only to products distributed by YAMAHA CORPORATION OF AMERICA.

(class B)

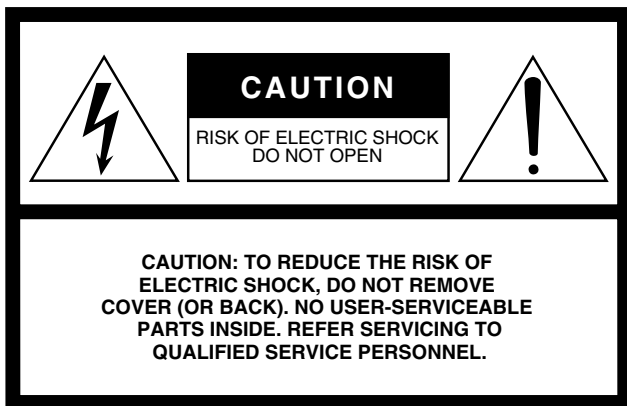

## Explanation of Graphical Symbols

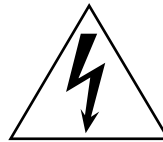

The lightning flash with arrowhead symbol within an equilateral triangle is intended to alert the user to the presence of uninsulated "dangerous voltage" within the product's enclosure that may be of sufficient magnitude to constitute a risk of electric shock to persons.



The exclamation point within an equilateral triangle is intended to alert the user to the presence of important operating and maintenance (servicing) instructions in the literature accompanying the product.

The above warning is located on the top of the unit.

# IMPORTANT SAFETY INSTRUCTIONS

- 1 Read these instructions.
- 2 Keep these instructions.
- 3 Heed all warnings.
- 4 Follow all instructions.
- 5 Do not use this apparatus near water.
- 6 Clean only with dry cloth.
- 7 Do not block any ventilation openings. Install in accordance with the manufacturer's instructions.
- 8 Do not install near any heat sources such as radiators, heat registers, stoves, or other apparatus (including amplifiers) that produce heat.
- 9 Do not defeat the safety purpose of the polarized or grounding-type plug. A polarized plug has two blades with one wider than the other. A grounding type plug has two blades and a third grounding prong. The wide blade or the third prong are provided for your safety. If the provided plug does not fit into your outlet, consult an electrician for replacement of the obsolete outlet.
- 10 Protect the power cord from being walked on or pinched particularly at plugs, convenience receptacles, and the point where they exit from the apparatus.

- 11 Only use attachments/accessories specified by the manufacturer.

- 12 Use only with the cart, stand, tripod, bracket, or table specified by the manufacturer, or sold with the apparatus. When a cart is used, use caution when moving the cart/apparatus combination to avoid injury from tip-over.



- 13 Unplug this apparatus during lightning storms or when unused for long periods of time.
- 14 Refer all servicing to qualified service personnel. Servicing is required when the apparatus has been damaged in any way, such as power-supply cord or plug is damaged, liquid has been spilled or objects have fallen into the apparatus, the apparatus has been exposed to rain or moisture, does not operate normally, or has been dropped.

## WARNING

TO REDUCE THE RISK OF FIRE OR ELECTRIC SHOCK, DO NOT EXPOSE THIS APPARATUS TO RAIN OR MOISTURE.

(98-6500)

# PRECAUTIONS

## PLEASE READ CAREFULLY BEFORE PROCEEDING

\* Please keep this manual in a safe place for future reference.



### WARNING

Always follow the basic precautions listed below to avoid the possibility of serious injury or even death from electrical shock, short-circuiting, damages, fire or other hazards. These precautions include, but are not limited to, the following:

#### Power supply/Power cord

- Only use the voltage specified as correct for the device. The required voltage is printed on the name plate of the device.
- Use only the included power cord.
- Do not place the power cord near heat sources such as heaters or radiators, and do not excessively bend or otherwise damage the cord, place heavy objects on it, or place it in a position where anyone could walk on, trip over, or roll anything over it.

#### Do not open

- Do not open the device or attempt to disassemble the internal parts or modify them in any way. The device contains no user-serviceable parts. If it should appear to be malfunctioning, discontinue use immediately and have it inspected by qualified Yamaha service personnel.

#### Water warning

- Do not expose the device to rain, use it near water or in damp or wet conditions, or place containers on it containing liquids which might spill into any openings.
- Never insert or remove an electric plug with wet hands.

#### If you notice any abnormality

- If the power cord or plug becomes frayed or damaged, or if there is a sudden loss of sound during use of the device, or if any unusual smells or smoke should appear to be caused by it, immediately turn off the power switch, disconnect the electric plug from the outlet, and have the device inspected by qualified Yamaha service personnel.
- If this device should be dropped or damaged, immediately turn off the power switch, disconnect the electric plug from the outlet, and have the device inspected by qualified Yamaha service personnel.



### CAUTION

Always follow the basic precautions listed below to avoid the possibility of physical injury to you or others, or damage to the device or other property. These precautions include, but are not limited to, the following:

#### Power supply/Power cord

- Remove the electric plug from the outlet when the device is not to be used for extended periods of time, or during electrical storms.
- When removing the electric plug from the device or an outlet, always hold the plug itself and not the cord. Pulling by the cord can damage it.

#### Location

- Before moving the device, remove all connected cables.
- If several of the devices are mounted in an EIA-compliant rack, carefully read the section "Rack Mounting" on page 10.
- Do not use the device in a confined, poorly-ventilated location. If this device is to be used in a small space other than an EIA-standard rack, make sure that there is adequate space between the device and surrounding walls or other devices: at least 5cm at the sides, 10cm behind and 10cm above. Inadequate ventilation can result in overheating, possibly causing damage to the device(s), or even fire.
- Do not expose the device to excessive dust or vibrations, or extreme cold or heat (such as in direct sunlight, near a heater, or in a car during the day) to prevent the possibility of panel disfiguration or damage to the internal components.

- Do not place the device in an unstable position where it might accidentally fall over.
- Do not block the vents. This device has ventilation holes at the front and rear to prevent the internal temperature from becoming too high. In particular, do not place the device on its side or upside down. Inadequate ventilation can result in overheating, possibly causing damage to the device(s), or even fire.
- Do not use the device in the vicinity of a TV, radio, stereo equipment, mobile phone, or other electric devices. Doing so may result in noise, both in the device itself and in the TV or radio next to it.

## Connections

- Before connecting the device to other devices, turn off the power for all devices. Before turning the power on or off for all devices, set all volume levels to minimum.
- Use only speaker cables for connecting speakers to the speaker jacks. Use of other types of cables may result in fire.
- Be sure to connect to a properly grounded power source. A ground screw is provided on the rear panel of this device for maximum safety and shock prevention. If the mains outlet is not grounded, be sure to connect the ground screw to a confirmed ground point before plugging the device into the mains. Improper grounding can result in electrical shock.

## Handling caution

- When turning on the AC power in your audio system, always turn on the device LAST, to avoid speaker damage. When turning the power off, the device should be turned off FIRST for the same reason.
- Do not insert your fingers or hands in any gaps or openings on the device (vents, etc.).
- Avoid inserting or dropping foreign objects (paper, plastic, metal, etc.) into any gaps or openings on the device (vents, etc.) If this happens, turn off the power immediately and unplug the power cord from the AC outlet. Then have the device inspected by qualified Yamaha service personnel.
- Do not use the device for a long period of time at a high or uncomfortable volume level, since this can cause permanent hearing loss. If you experience any hearing loss or ringing in the ears, consult a physician.
- Do not rest your weight on the device or place heavy objects on it, and avoid use excessive force on the buttons, switches or connectors.
- Do not use this device for any purpose other than driving loudspeakers.

Use only Neutrik NL4FC plugs for connecting Speakon connectors.

Yamaha cannot be held responsible for damage caused by improper use or modifications to the device.

Always turn the power off when the device is not in use.

The performance of components with moving contacts, such as switches, volume controls, and connectors, deteriorates over time. Consult qualified Yamaha service personnel about replacing defective components.

Illustrations in this manual are for explanatory purposes only, and may not match the actual appearance of the product during operation.

Company names and product names used in this Owner's Manual are trademarks or registered trademarks of their respective owners.

# Introduction

---

Thank you for purchasing a Yamaha PC9501N, PC6501N, PC4801N, PC3301N, or PC2001N Series Power Amplifier.

The PC Series of power amplifiers was developed from Yamaha's wealth of experience in building PA equipment and its tradition of careful attention to every detail of circuit design. These power amplifiers feature high power and superb quality together with superior reliability and stability, guaranteeing the highest possible audio performance.

Main features include

- Three modes are provided to support a broad range of applications: STEREO mode which can be driven by two independent sources, PARALLEL mode in which a monaural source drives both channels, and BRIDGE mode in which the two internal amps function as a single mono amp.
- Balanced XLR connector and Euroblock connector inputs, and Speakon connector and five-way binding post outputs are provided.
- A high pass filter switch that cuts frequencies below 20 Hz, and detented attenuators and level meters for channels A and B are provided.
- Metering and indicators include easily visible two-channel level meters, a PROTECTION indicator that shows the state of various protection systems (power on/off detection, output protection, DC detection), a TEMP indicator that indicates heat sink overheating, and a REMOTE indicator that indicates the external remote status.
- Variable-speed low-noise fans ensure high reliability.
- The PC3301N enables parallel connection of multiple high-impedance speakers that support 100 V line output.
- An optional external amp control unit, such as the ACU-16C, enables you to monitor or control the amplifier via a network. For the latest information about amp control units, please visit our website: <http://www.yamahaproaudio.com/>

This Owner's Manual applies to the PC9501N, PC6501N, PC4801N, PC3301N, and PC2001N power amplifier. In order to take full advantage of your power amplifier and enjoy long and trouble-free operation, please read this Owner's Manual carefully before using your Power Amplifier.

## Contents

---

<b>Introduction .....</b>	<b>5</b>
<b>Controls and Functions .....</b>	<b>6</b>
Front Panel.....	6
Rear Panel .....	7
Speaker connections.....	8
<b>Connection .....</b>	<b>9</b>
Using a Euroblock connector .....	9
Speaker Connection.....	9
<b>Air Flow .....</b>	<b>10</b>
<b>Rack Mounting .....</b>	<b>10</b>
<b>Specifications .....</b>	<b>11</b>
General Specifications .....	11
Block Diagram.....	12
Dimensions .....	13
<b>Troubleshooting .....</b>	<b>14</b>
<b>Performance graph .....</b>	<b>14</b>

# Controls and Functions

## ■ Front Panel

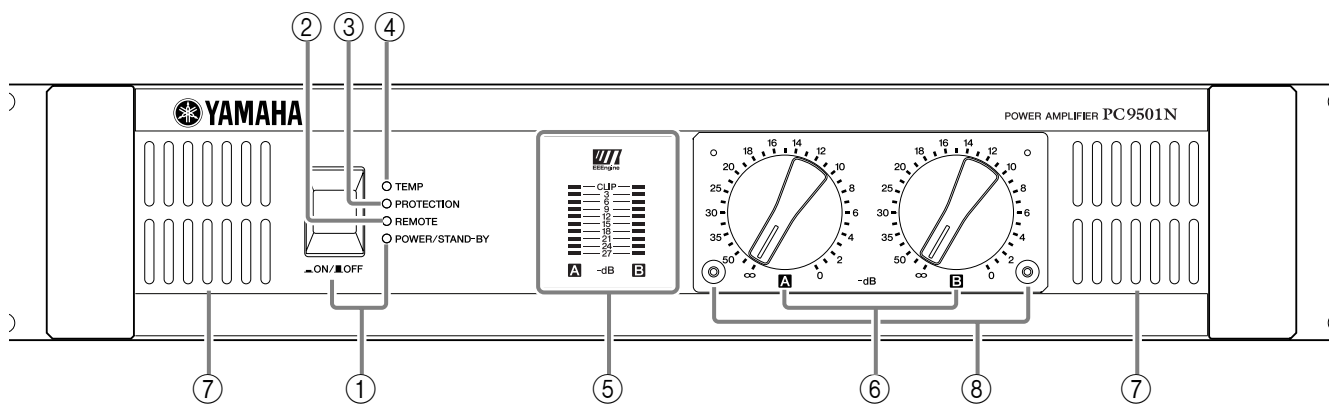

- ① **POWER/STAND-BY switch and indicator**  
This turns the power of the amplifier on/off. When you press the switch to turn on the power, the indicator will light green.  
If the amplifier is connected to an amp control unit ACU16-C and the amplifier has been commanded to enter STAND-BY mode, this indicator will light orange.

- ② **REMOTE indicator**  
This indicator will light green if the amplifier is being controlled from an external device connected to the DATA port located on the rear panel.

- ③ **PROTECTION indicator**  
This indicator lights up red when the protection circuit is operating. During this time, the amp will be disconnected from the speaker system, and no sound will be output from the speaker.  
The protection system activates in the following situations:

- **When the amplifier is turned on**

The protection system activates for approximately ten seconds when the amplifier is turned on. After ten seconds, the protection system deactivates automatically and the amplifier is ready for normal operation.

- **If a DC voltage is detected at the amplifier's outputs**

Turn off the power, and then turn the power back on again.

- **If the amplifier overheats**

When this occurs, the TEMP indicator will be lit. You should turn off the amplifier and allow it time to cool down. See the Precautions section of this Owner's Manual for ways to prevent the amplifier overheating.

- ④ **TEMP indicator**  
This indicator will light red if the heat sink temperature exceeds 85 degrees Celsius.

- ⑤ **Level meters**  
These are nine-segment level meters that indicate the output level of output jacks A and B. If the distortion of the output signal exceeds 1%, the red CLIP indicator will light.

- ⑥ **Volume knobs**  
These are detented volume knobs that attenuate the input signals of channels A and B over a range of  $-\infty$  – 0 dB.  
In BRIDGE mode, only the channel A knob is used.

- ⑦ **Air intakes**  
The amplifier has a forced-air cooling fan that takes in air from the front and exhausts it from the rear. You must make sure that these intakes are not obstructed.

- ⑧ **Security cover**  
If you want to keep the volume settings from being modified, attach the included security cover using the screw holes shown below, so that the volume controls are inaccessible.

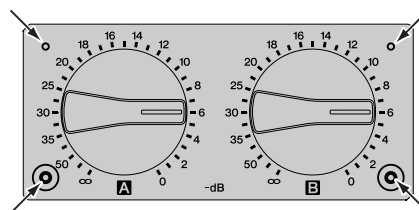

## ■ Rear Panel

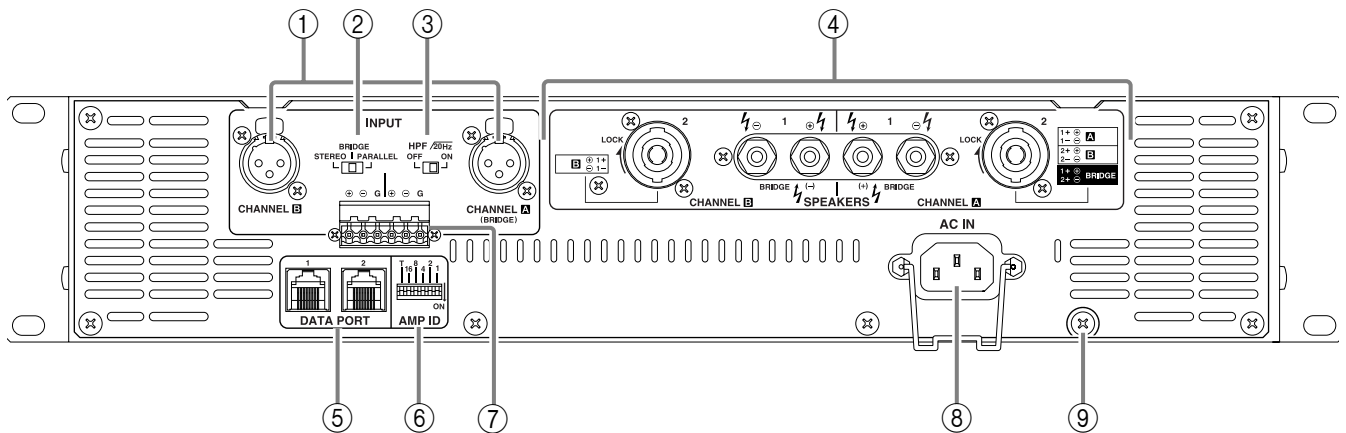

### ① XLR inputs

These balanced XLR-3-31 type connectors are used to connect input signals. They are wired pin 1–ground, pin 2–hot (+), and pin 3–cold (–).

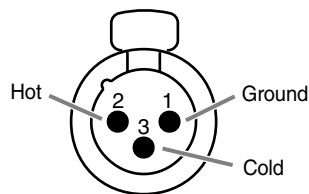

In Bridge mode, only the XLR input of the channel A is active.

### ② MODE switch

#### • STEREO mode

Channels A and B will operate independently.

#### • PARALLEL mode

In PARALLEL mode, the channel A input signal will be sent to the channel A power amp and to the channel B power amp. The channel B input jack is not used.

#### • BRIDGE mode

In BRIDGE mode, channels A and B will operate simultaneously, functioning as a single mono amp.

### ③ HPF/20 switches

These switches are used to turn on and off the HPF (High Pass Filter) for each channel. When set to ON, frequencies below 20 Hz are filtered using a 12 dB/octave high pass filter.

### ④ SPEAKERS jacks

- These are Speakon type output jacks. Speakon type cable plugs can be connected here.
- These are five-way binding post output jacks.

### ⑤ DATA PORT jack

An amp control unit, such as the ACU16-C, can be connected to the DATA PORT jack for monitoring or controlling the amplifier from the external device.

### ⑥ AMP ID switch

When an amp control unit, such as the ACU16-C, is connected to the DATA PORT jack ⑤, the AMP ID switch can be used to set the amplifier's ID.

### ⑦ Euroblock connector

This is a balanced input jack. The included Euroblock connector can be used to make connections here.

### ⑧ AC inlet

Connect the socket of the included AC cable to this inlet. Connect the plug of the AC cable to an AC outlet that meets the power supply conditions printed below this inlet.

### ⑨ GROUND Screw terminal

If you are having a problem with hum or noise, use this terminal to connect to ground or to connect to the chassis of the mixer, preamp, or other device in your system.

## ■ Speaker connections

Speakers can be connected to the amplifier as shown below. Note that speaker impedance will vary according to the connection method and the number of speakers. Please be sure that your speaker's impedance is not less than the relevant minimum value indicated below.

### Connection configurations for STEREO and PARALLEL modes

When using 5-way binding post output jacks

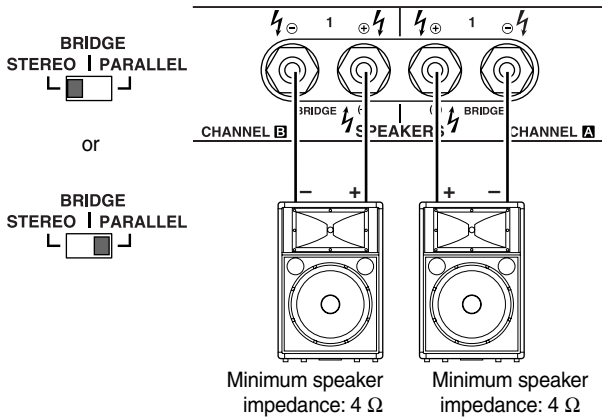

When using the Speakon connector

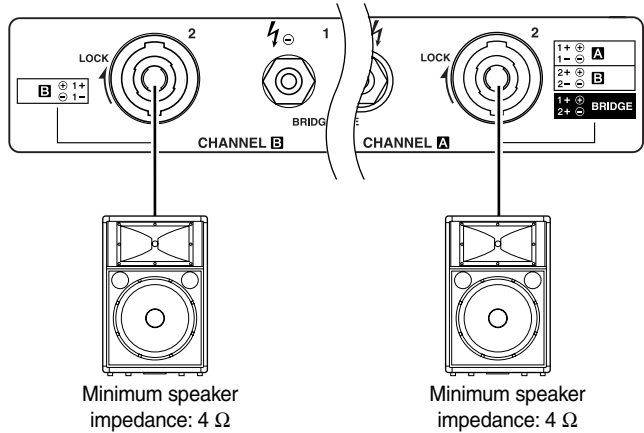

### Connection configurations for BRIDGE mode

When using 5-way binding post output jacks

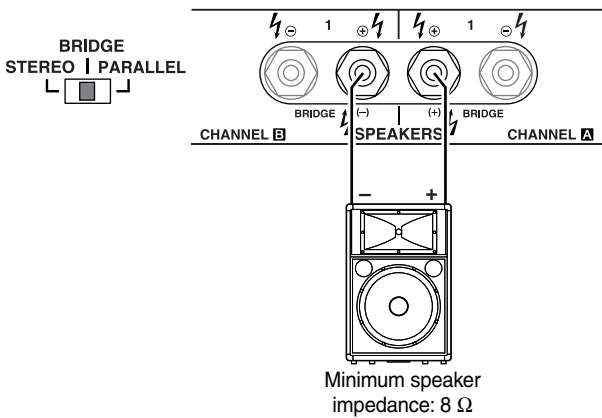

When using the Speakon connector

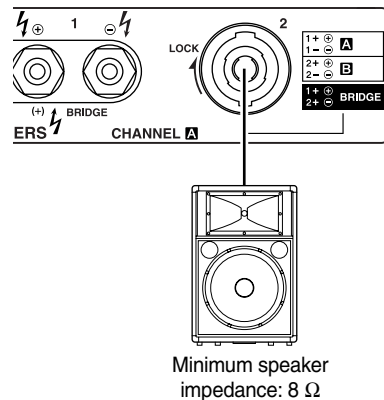

### When connecting high-impedance speakers in parallel (PC3301N only)

The number of speakers that can be connected varies depending on the rated input of the speakers. The PC3301N can be connected to speakers with a total rated input of up to 625 W. For example, if you connect five speakers with a rated input of 5 W (25 W), thirty speakers with a rated input of 10 W (300 W) and twenty speakers with a rated input of 15 W (300 W), the amplifier can be used with a total rated speaker input of 625 W as shown below:

**⚠ CAUTION** Be sure to use speakers that support the PC3301N's line-out voltage of 100 V.

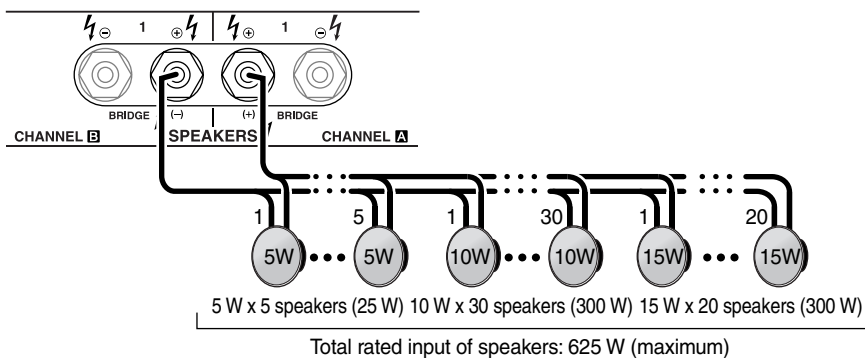



# Connection

## ■ Using a Euroblock connector

1. If the wire insertion ports are closed, turn the screws on top of the connector counterclockwise to open the ports.
2. Insert the wires into the appropriate ports, following the indication of the pole on the input terminal, turn the screws on top of the connector clockwise to fix the wires.
3. Attach the Euroblock connector to the input terminal on the unit.

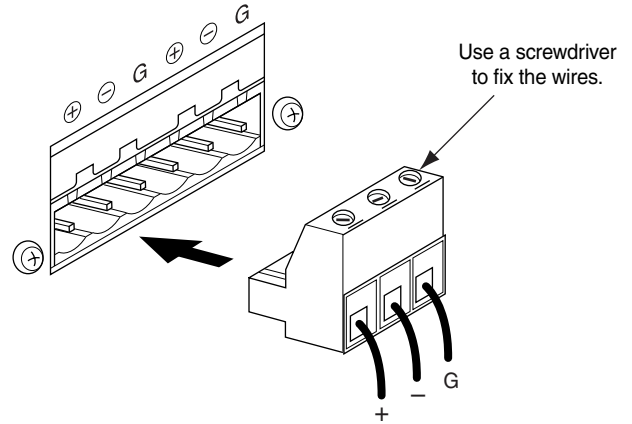

## ■ Speaker Connection

### 5-way binding post

1. Turn off the POWER switch.
2. Remove the cover attachment screws and remove the protective cover from the speaker terminals.

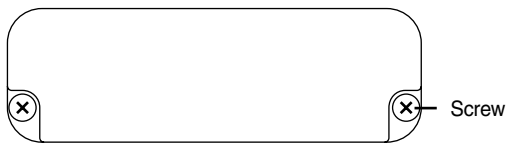

3. Remove about 15 mm of insulation from the end of each speaker cable, and pass the bare wire through the holes in the appropriate speaker terminals. Tighten the terminals to securely clamp the wires. Refer to page 8 for speaker polarities.

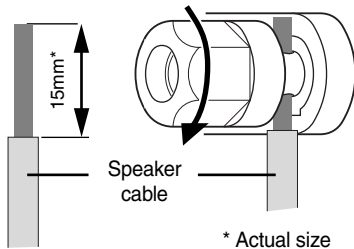

Be sure that the bare wire ends do not jut out from the terminals and touch the chassis. The following shows how the cable should look when correctly attached.

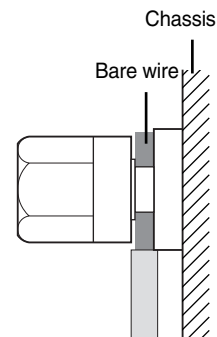

Note to users in the USA:  
Please use Class 3 wiring. (PC9501N, PC6501N, PC4801N)  
Please use Class 2 wiring. (PC3301N, PC2001N)

4. Reattach the protective cover over the speaker terminals.

### Speakon connector

1. Turn off the POWER switch.
2. Insert the Neutrik NL4FC plugs into the Speakon connector on the rear of the amplifier, and turn clockwise to lock.

### Neutrik NL4FC plugs

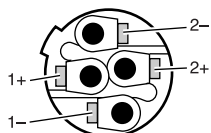

CHANNEL **A**  
STEREO or PARALLEL

Neutrik	Amplifier
1+	A+
1-	A-
2+	B+
2-	B-

BRIDGE

Neutrik	Amplifier
1+	+
1-	
2+	-
2-	

CHANNEL **B**

Neutrik	Amplifier
1+	B+
1-	B-

# Air Flow

This unit uses a forced cooling system in which air comes in through the front opening and goes out the rear.

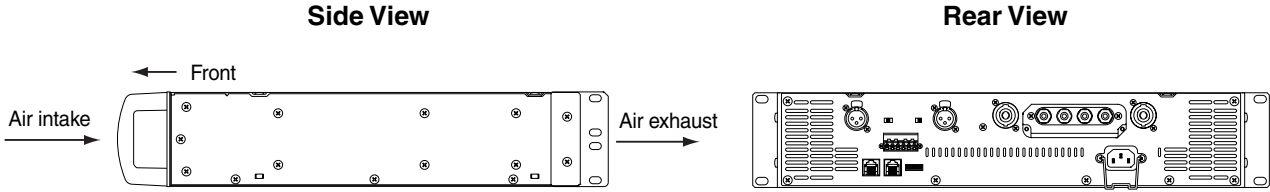

# Rack Mounting

If multiple high-power amp units are mounted in a rack with poor ventilation, the heat from the amps will cause the interior of the amp to become very hot, causing the performance of the amps to be impaired. In particular, when mounting in a rack whose back can not be left open, mount according to the following instructions.

- Rack:** Leave a gap of 10 cm or more between the rear panel of the rack and the rear panel of the amplifier.
- Fan:** Use a fan with 1.5 m<sup>3</sup>/min or more maximum wind and 5 mmH<sub>2</sub>O or more maximum static pressure.
- Mounting:** Install the fan kit on the top slot or the top panel of the rack and install a blanking panel between two amps.

If the unit is rack mounted and transported frequently, we recommend that the rear of the unit be supported by fitting a pair of metal brackets, one each side.

### Example of mounting

The top figure shows an example of a fan kit (panels and two fans) on the top slot of the rack. The fans are Minebea 3115PS-12T-B30 (with 0.9 m<sup>3</sup>/min maximum wind and 5 mmH<sub>2</sub>O maximum static pressure).

The bottom figure is a dimensional diagram of a panel on which two 3115PS-12T-B30 are installed.

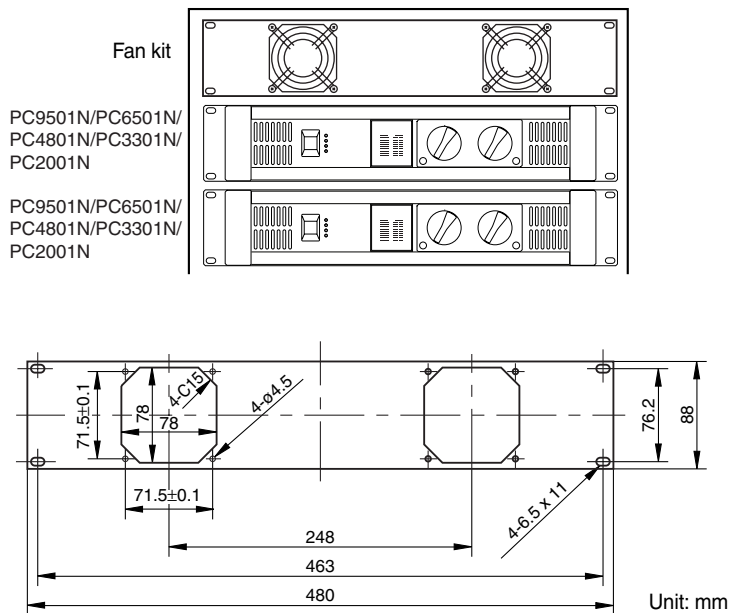

# Specifications

## General Specifications

		PC9501N		PC6501N		PC4801N		PC3301N		PC2001N	
<b>Output Power</b> 1 kHz, THD+N= 1% 8 Ω/STEREO 4 Ω/STEREO 8 Ω/BRIDGE	MIN	120V(US)/240V(A)	230V(EU)	120V(US)/240V(A)	230V(EU)	120V(US)/240V(A)	230V(EU)	120V(US)/240V(A)	230V(EU)	120V(US)/240V(A)	230V(EU)
		1000 W x 2	1050 W x 2	700 W x 2	750 W x 2	550 W x 2	500 W x 2	350 W x 2	400 W x 2	230 W x 2	250 W x 2
		1600 W x 2	1650 W x 2	1100 W x 2	1150 W x 2	850 W x 2	800 W x 2	600 W x 2	700 W x 2	400 W x 2	450 W x 2
		3200 W	3300 W	2200 W	2300 W	1700 W	1600 W	1200 W	1400 W	800 W	900 W
20 Hz–20 kHz THD+N= 0.1% 8 Ω/STEREO 4 Ω/STEREO 8 Ω/BRIDGE 16 Ω/BRIDGE(100V)	MIN	925 W x 2	950 W x 2	650 W x 2	650 W x 2	475 W x 2	450 W x 2	330 W x 2	350 W x 2	200 W x 2	230 W x 2
		1400 W x 2	1500 W x 2	930 W x 2	930 W x 2	725 W x 2	700 W x 2	525 W x 2	550 W x 2	325 W x 2	400 W x 2
		2800 W	3000 W	1860 W	1860 W	1450 W	1400 W	1050 W	1100 W	650 W	800 W
		–	–	–	–	–	–	625 W	625 W	–	–
1 kHz 20ms nonclip 2 Ω/STEREO 4 Ω/BRIDGE	MIN	2300 W x 2	2300 W x 2	1500 W x 2	1600 W x 2	1200 W x 2	1200 W x 2	800 W x 2	900 W x 2	500 W x 2	600 W x 2
		4600 W	4600 W	3000 W	3200 W	2400 W	2400 W	1600 W	1800 W	1000 W	1200 W
<b>Power Bandwidth</b> Half Power	MIN	10 Hz–40 kHz (THD+N= 0.5%)									
<b>Total Harmonic Distortion (THD + N)</b> 20 Hz–20 kHz, Half Power	MAX	0.1%									
<b>Frequency Response</b> RL= 8 Ω, Po= 1 W f=20 Hz–50 kHz	MAX	0 dB									
	TYP	0 dB									
	MIN	–1 dB									
<b>Intermodulation distortion (IMD)</b> 60 Hz:7 kHz, 4:1, Half Power	MAX	0.1%									
<b>Channel Separation</b> Half Power, RL= 8 Ω, 1 kHz, Vol. max., input 600 Ω shunt	MIN	70 dB									
<b>Residual Noise</b> Vol. min., 20 Hz–20 kHz (DIN AUDIO)	MAX	–70 dB									
<b>SN Ratio</b> 20 Hz–20 kHz (DIN AUDIO)	MIN	106 dB		105 dB		103 dB		101 dB		100 dB	
<b>Damping Factor</b> RL=8 Ω, f= 1 kHz	MIN	800								500	
<b>Sensitivity</b> (Vol. max.) Rated Power into 8 Ω	TYP	9 dB		8 dB		6 dB		4.5 dB		3 dB	
<b>Voltage Gain (Vol. max.)</b>	TYP	32 dB									
<b>Maximum Input Voltage</b>	MIN	22 dB									
<b>Input Impedance</b>	TYP	20 kΩ/Balanced, 10 kΩ/Unbalanced									
<b>Controls</b> Front Panel ----- Rear Panel	POWER switch (ON/OFF) Two 31-step Volume knobs (one per ch)										
	MODE switch (STEREO/BRIDGE/PARALLEL) HPF switch (ON/OFF) fc=20 Hz 12 dB/octave DIP switch (6P)										
<b>Connectors</b> Input ----- Output ----- Network ----- Power	XLR–3–31 type/ch Euroblock connector/ch										
	SPEAKON/ch, 5-way binding posts										
	RJ45 x 2										
	AC inlet										
<b>Indicators</b> POWER/STAND-BY ----- PROTECTION ----- TEMP ----- REMOTE	Green/Orange										
	Red										
	Red (heatsink temp ≥ 85 °C)										
	Green										
<b>Level Meters</b>	10 points LED meter/ch										
<b>Load protection</b>	POWER switch ON muting, DC detection										
<b>Amp. Protection</b>	Temp. detection (heatsink temp ≥ 90 °C), VI limiter (RL ≤ 1Ω)										
<b> Limiter</b>	Comp. : THD ≥ 0.5%										
<b>Cooling</b>	Dual Variable-speed fan										
<b>Power Consumption</b> Idling ----- Output power, 4 Ω	55 W			40 W							
	750 W (US)/1000 W(A)	1100 W	700 W (US)/800 W(A)	800 W	450 W (US)/600 W(A)	600 W	450 W (US)/500 W(A)	500 W	350 W		
<b>Dimensions (W x H x D)</b>	480 x 88 x 456 mm										
<b>Weight</b>	13 kg					12.5 kg					
<b>Included accessories</b>	Power cord, Security cover, Owner's Manual, 3-pin Euroblock connector x 2										

0 dB=0.775 Vrms, Half Power=1/2 Output Power (3 dB below rated power)  
Specifications and descriptions in this owner's manual are for information purposes only.  
Yamaha Corp. reserves the right to change or modify products or specifications at any time  
without prior notice. Since specifications, equipment or options may not be the same in  
every locale, please check with your Yamaha dealer.

European models  
Purchaser/User Information specified in EN55103-1 and EN55103-2.  
Inrush Current: 31A  
Conforms to Environments: E1, E2, E3 and E4

# Block Diagram

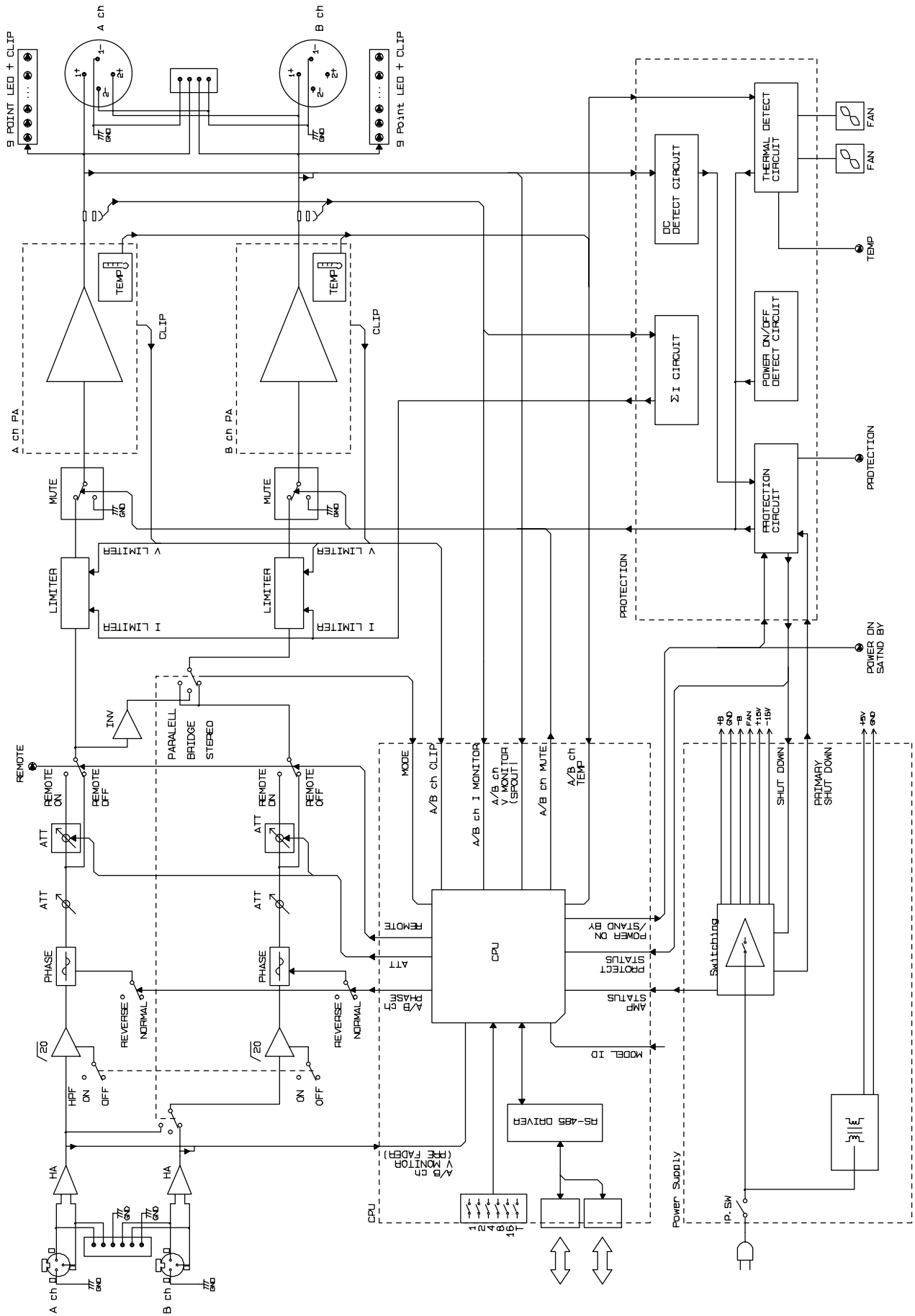

## ■ Dimensions

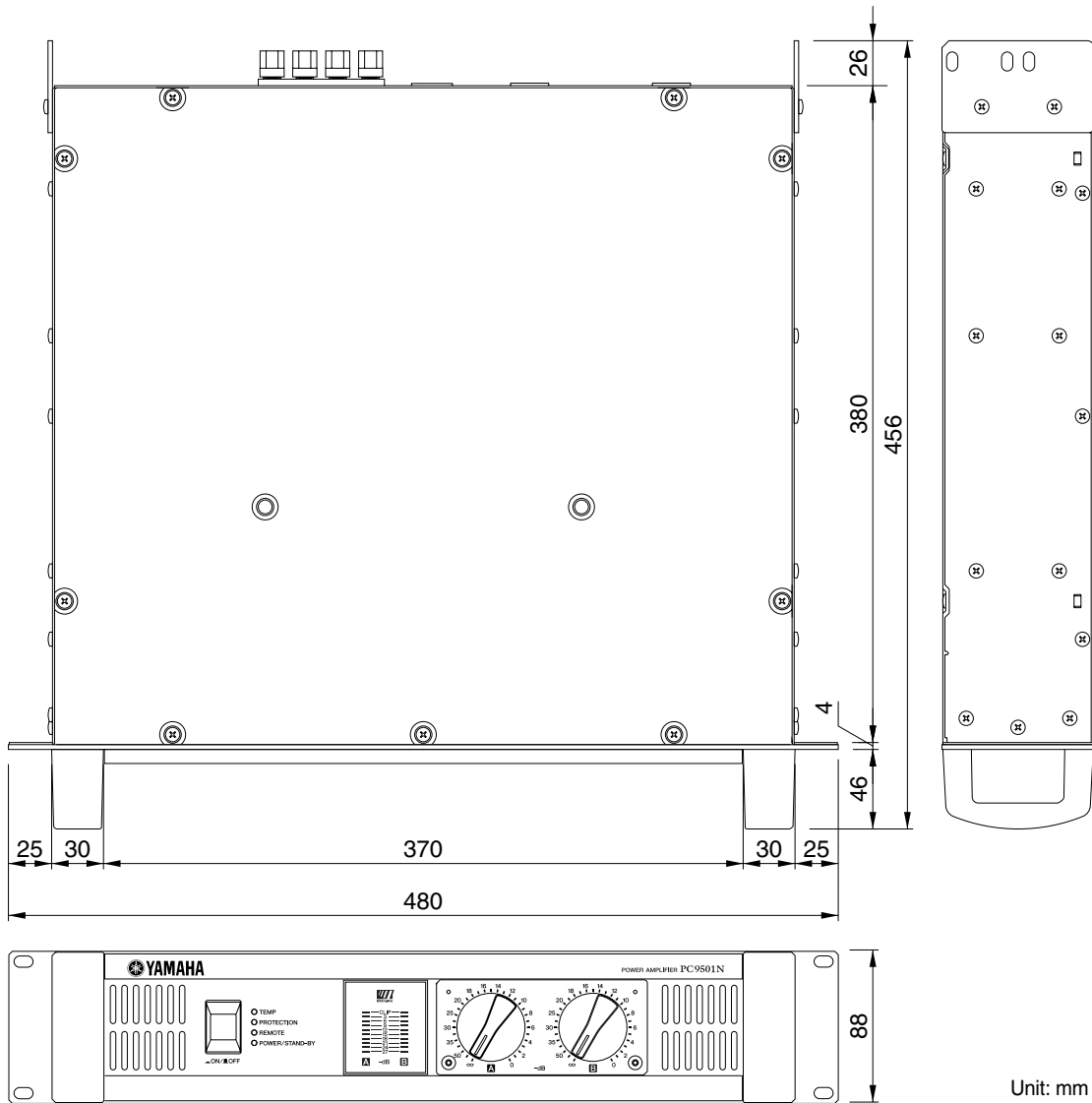

# Troubleshooting

The following table lists the main causes of abnormal operation and the corrective measures required as well as the protective circuit operation in each case.

Indicator	Possible Cause	Remedy	Protection Circuit
CLIP indicator lights up	There is a short at the amplifier's speaker outputs, the speaker's inputs, or in the wiring.	Locate and remove the short.	The PC limiter circuit activates to protect the power transistors.
	The impedance of the connected speaker is too low.	Use a speaker with a minimum impedance of 4Ω (8Ω in Bridge mode).	
PROTECTION indicator lights up	The heat sink temperature has exceeded 90°C.	Check the ventilation around the amplifier and improve the airflow if necessary.	The thermal protection circuit activates to protect the power transistors.
	A DC voltage of ±2 V or greater was detected in the amplifier's output circuit.	Consult your dealer or a Yamaha service center.	The output relay activates to protect the speaker system.

# Performance graph

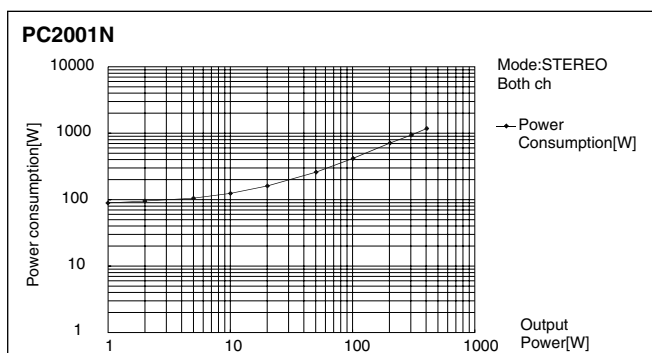
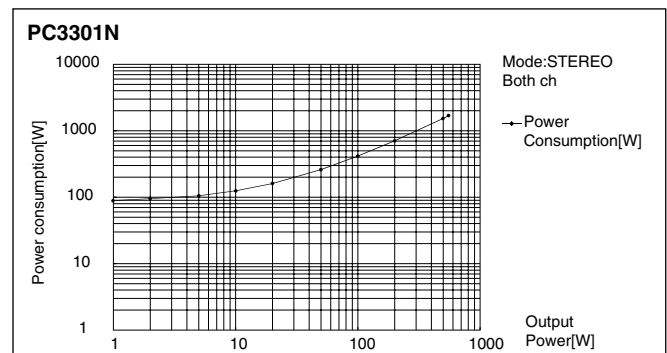
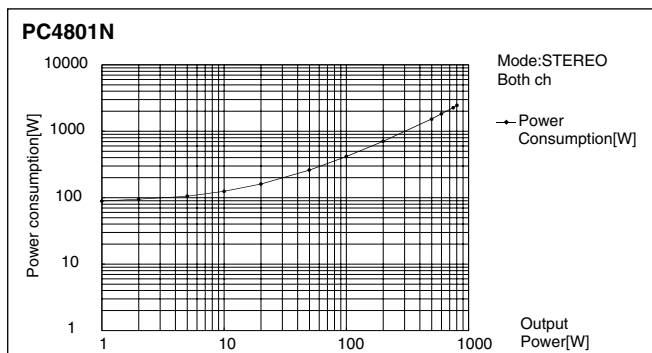
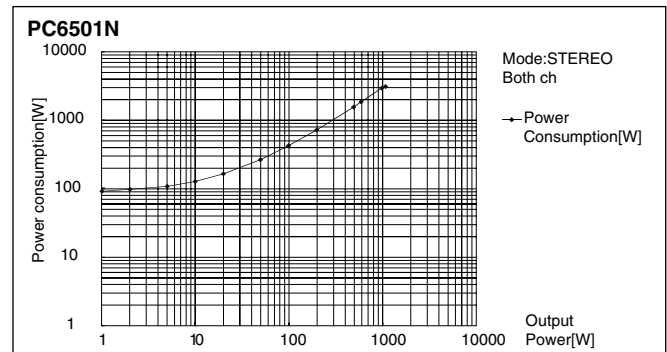
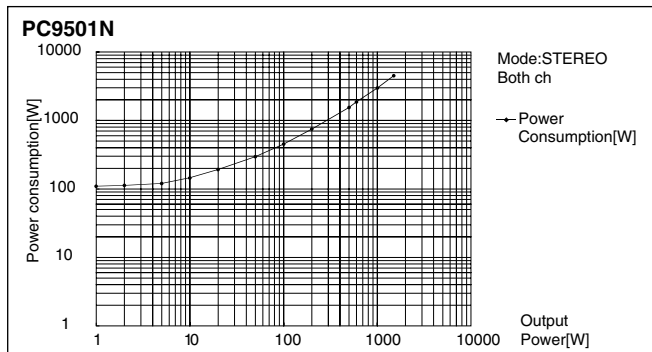

## IMPORTANT NOTICE FOR THE UNITED KINGDOM

### Connecting the Plug and Cord

**WARNING: THIS APPARATUS MUST BE EARTHED**  
IMPORTANT. The wires in this mains lead are coloured in accordance with the following code:

GREEN-AND-YELLOW : EARTH  
BLUE : NEUTRAL  
BROWN : LIVE

As the colours of the wires in the mains lead of this apparatus may not correspond with the coloured markings identifying the terminals in your plug proceed as follows:

The wire which is coloured GREEN-and-YELLOW must be connected to the terminal in the plug which is marked by the letter E or by the safety earth symbol  $\oplus$  or colored GREEN or GREEN-and-YELLOW.

The wire which is coloured BLUE must be connected to the terminal which is marked with the letter N or coloured BLACK.

The wire which is coloured BROWN must be connected to the terminal which is marked with the letter L or coloured RED.

• This applies only to products distributed by Yamaha-Kemble Music (U.K.) Ltd. (3 wires)

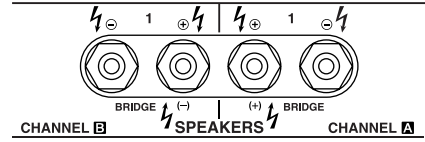

This ⚡ mark indicates a dangerous electrically live terminal.

When connecting an external wire to this terminal, it is necessary either to have "a person who have received appropriate guidance on handling" make the connection or to use leads or a cord that have been manufactured in such a way that the connection can be made simply and without problem.

For details of products, please contact your nearest Yamaha representative or the authorized distributor listed below.

Pour plus de détails sur les produits, veuillez-vous adresser à Yamaha ou au distributeur le plus proche de vous figurant dans la liste suivante.

Die Einzelheiten zu Produkten sind bei Ihrer unten aufgeführten Niederlassung und bei Yamaha Vertragshändlern in den jeweiligen Bestimmungsländern erhältlich.

Para detalles sobre productos, contacte su tienda Yamaha más cercana o el distribuidor autorizado que se lista debajo.

## NORTH AMERICA

### CANADA

**Yamaha Canada Music Ltd.**  
135 Milner Avenue, Scarborough, Ontario,  
M1S 3R1, Canada  
Tel: 416-298-1311

### U.S.A.

**Yamaha Corporation of America**  
6600 Orangethorpe Ave., Buena Park, Calif. 90620,  
U.S.A.  
Tel: 714-522-9011

## CENTRAL & SOUTH AMERICA

### MEXICO

**Yamaha de México S.A. de C.V.**  
Calz. Javier Rojo Gómez #1149,  
Col. Guadalupe del Moral  
C.P. 09300, México, D.F., México  
Tel: 55-5804-0600

### BRAZIL

**Yamaha Musical do Brasil Ltda.**  
Av. Reboucas 2636-Pinheiros CEP: 05402-400  
Sao Paulo-SP. Brasil  
Tel: 011-3085-1377

### ARGENTINA

**Yamaha Music Latin America, S.A.**  
**Sucursal de Argentina**  
Viamonte 1145 Piso2-B 1053,  
Buenos Aires, Argentina  
Tel: 1-4371-7021

### PANAMA AND OTHER LATIN AMERICAN COUNTRIES/ CARIBBEAN COUNTRIES

**Yamaha Music Latin America, S.A.**  
Torre Banco General, Piso 7, Urbanización Marbella,  
Calle 47 y Aquilino de la Guardia,  
Ciudad de Panamá, Panamá  
Tel: +507-269-5311

## EUROPE

### THE UNITED KINGDOM

**Yamaha-Kemble Music (U.K.) Ltd.**  
Sherbourne Drive, Tilbrook, Milton Keynes,  
MK7 8BL, England  
Tel: 01908-366700

### GERMANY

**Yamaha Music Central Europe GmbH**  
Siemensstraße 22-34, 25462 Rellingen, Germany  
Tel: 04101-3030

### SWITZERLAND/LIECHTENSTEIN

**Yamaha Music Central Europe GmbH,**  
**Branch Switzerland**  
Seefeldstrasse 94, 8008 Zürich, Switzerland  
Tel: 01-383 3990

### AUSTRIA

**Yamaha Music Central Europe GmbH,**  
**Branch Austria**  
Schleiergasse 20, A-1100 Wien, Austria  
Tel: 01-60203900

### THE NETHERLANDS

**Yamaha Music Central Europe,**  
**Branch Nederland**  
Clarissenhof 5-b, 4133 AB Vianen, The Netherlands  
Tel: 0347-358 040

## BELGIUM/LUXEMBOURG

**Yamaha Music Central Europe GmbH,**  
**Branch Belgium**  
Rue de Geneve (Genevestraat) 10, 1140 - Brussels,  
Belgium  
Tel: 02-726 6032

## FRANCE

**Yamaha Musique France**  
BP 70-77312 Marne-la-Vallée Cedex 2, France  
Tel: 01-64-61-4000

## ITALY

**Yamaha Musica Italia S.P.A.**  
**Combo Division**  
Viale Italia 88, 20020 Lainate (Milano), Italy  
Tel: 02-935-771

## SPAIN/PORTUGAL

**Yamaha-Hazen Música, S.A.**  
Ctra. de la Coruna km. 17, 200, 28230  
Las Rozas (Madrid), Spain  
Tel: 91-639-8888

## SWEDEN

**Yamaha Scandinavia AB**  
J. A. Wettergrens Gata 1  
Box 30053  
S-400 43 Göteborg, Sweden  
Tel: 031 89 34 00

## DENMARK

**YS Copenhagen Liaison Office**  
Generatorvej 6A  
DK-2730 Herlev, Denmark  
Tel: 44 92 49 00

## NORWAY

**Norsk filial av Yamaha Scandinavia AB**  
Grini Næringspark 1  
N-1345 Østerås, Norway  
Tel: 67 16 77 70

## OTHER EUROPEAN COUNTRIES

**Yamaha Music Central Europe GmbH**  
Siemensstraße 22-34, 25462 Rellingen, Germany  
Tel: +49-4101-3030

## AFRICA

**Yamaha Corporation,**  
**Asia-Pacific Music Marketing Group**  
Nakazawa-cho 10-1, Hamamatsu, Japan 430-8650  
Tel: +81-53-460-2313

## MIDDLE EAST

### TURKEY/CYPRUS

**Yamaha Music Central Europe GmbH**  
Siemensstraße 22-34, 25462 Rellingen, Germany  
Tel: 04101-3030

### OTHER COUNTRIES

**Yamaha Music Gulf FZE**  
LB21-128 Jebel Ali Freezone  
P.O.Box 17328, Dubai, U.A.E.  
Tel: +971-4-881-5868

## ASIA

### THE PEOPLE'S REPUBLIC OF CHINA

**Yamaha Music & Electronics (China) Co.,Ltd.**  
25/F., United Plaza, 1468 Nanjing Road (West),  
Jingan, Shanghai, China  
Tel: 021-6247-2211

### INDONESIA

**PT. Yamaha Music Indonesia (Distributor)**  
**PT. Nusantik**  
Gedung Yamaha Music Center, Jalan Jend. Gatot  
Subroto Kav. 4, Jakarta 12930, Indonesia  
Tel: 21-520-2577

### KOREA

**Yamaha Music Korea Ltd.**  
Tong-Yang Securities Bldg. 16F 23-8 Yoido-dong,  
Youngdungpo-ku, Seoul, Korea  
Tel: 02-3770-0660

### MALAYSIA

**Yamaha Music Malaysia, Sdn., Bhd.**  
Lot 8, Jalan Perbandaran, 47301 Kelana Jaya,  
Petaling Jaya, Selangor, Malaysia  
Tel: 3-78030900

### SINGAPORE

**Yamaha Music Asia Pte., Ltd.**  
#03-11 A-Z Building  
140 Paya Lebor Road, Singapore 409015  
Tel: 747-4374

### TAIWAN

**Yamaha KHS Music Co., Ltd.**  
3F, #6, Sec.2, Nan Jing E. Rd. Taipei.  
Taiwan 104, R.O.C.  
Tel: 02-2511-8688

### THAILAND

**Siam Music Yamaha Co., Ltd.**  
891/1 Siam Motors Building, 15-16 floor  
Rama 1 road, Wangmai, Pathumwan  
Bangkok 10330, Thailand  
Tel: 02-215-2626

### OTHER ASIAN COUNTRIES

**Yamaha Corporation,**  
**Asia-Pacific Music Marketing Group**  
Nakazawa-cho 10-1, Hamamatsu, Japan 430-8650  
Tel: +81-53-460-2317

## OCEANIA

### AUSTRALIA

**Yamaha Music Australia Pty. Ltd.**  
Level 1, 99 Queensbridge Street, Southbank,  
Victoria 3006, Australia  
Tel: 3-9693-5111

### COUNTRIES AND TRUST

### TERRITORIES IN PACIFIC OCEAN

**Yamaha Corporation,**  
**Asia-Pacific Music Marketing Group**  
Nakazawa-cho 10-1, Hamamatsu, Japan 430-8650  
Tel: +81-53-460-2313

**HEAD OFFICE** Yamaha Corporation, Pro Audio & Digital Musical Instrument Division  
Nakazawa-cho 10-1, Hamamatsu, Japan 430-8650  
Tel: +81-53-460-2441