

Model No.

ES-52T

In-Ceiling Speaker



INCLUDES:

- 5-1/4 inch coaxial driver
- C-ring with support rails
- 16W transformer (with bypass)
- Paper template for ceiling cut-outs
- Steel enclosure (with dog ears)
- Plastic paint shield for driver
- Press-fit grille, scrim, pull-tool

RECESSED SPEAKER produces excellent intelligibility for speech and full frequency response for music making it ideal for retail, commercial, industrial, institutional and residential applications. This self-contained speaker is for in-ceiling or in-wall installations.

FEATURES

PERFORMANCE: Suitable for a variety of applications that require clear speech and full frequency music.

DRIVER: 5-1/4 inch coaxial

- High frequency Mylar tweeter with acoustic lens to provide a crisp high-frequency response.
- Wide dispersion (165 degrees conical) can reduce the number of speakers required for even coverage in distributed speaker systems.

TRANSFORMER: 16W

- Tap selections for 25V, 70V or 100V speaker systems
- 8ohm transformer bypass position
- Selector switch behind grille

GRILLE: Fine mesh 20-gauge steel press-fit grille with white finish, scrim and pull tool.

ENCLOSURE: Factory-mounted enclosure ships attached to the driver (non-removable).

- Durable 20-gauge steel with grey finish.
- Ported enclosure tuned for extended bass response
- Built-in mounting dogs aid fast installation, while allowing the speaker to mount in drywall, wood, tile or almost any type of ceiling with thickness of 0.1 inches up to 1.4 inches.
- Removable (4 pin) Phoenix-style connector with 2 terminals for input to speaker and 2 parallel terminals for output to next speaker in string.
- Seismic restraint ring tie-off
- Internal volume 379 cu.in.

BAFFLE: Low-profile front baffle formed from UV-rated high impact plastic.

C-RING & SUPPORT RAILS: Ring reinforces edge of drywall ceiling cut-outs and works with the two support rails to help distribute weight of speaker assembly to help prevent sagging tiles in lay-in tile ceilings.

TEMPLATE: Paper template to properly mark ceiling cut-outs for mounting holes.

PAINT GUARD: Plastic shield fits over the driver to protect it when baffle is painted.

COMPLIANCE:

- UL1480A General Signaling, USA
- UL 2043 Return air plenum space
- CSA C22.2 No.205-12 General Signaling, Canada

ACCESSORIES (order separately)

- **ES-6-RIB Rough-in Bridge:** Galvanized steel bridge serves as a placeholder for speaker in new construction (drywall or plaster ceiling) before finished ceiling is installed.
- **ES-6-RTR Retrofit Trim Ring:** Mounts speaker to an existing (installed) 8-inch speaker enclosure with 11.25-inch diameter mounting bolt circle. See accessory spec sheet for additional requirements.



FEATURES



Enclosure dog ears help to speed in-ceiling installations.



Front tap selector switch is protected behind the press-fit grille.

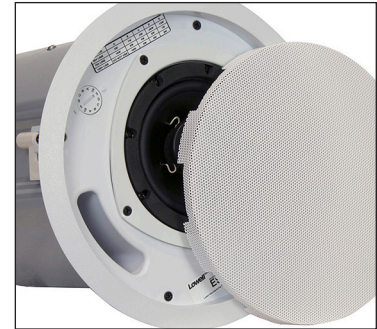

Fine mesh CRS white grille presses into position.

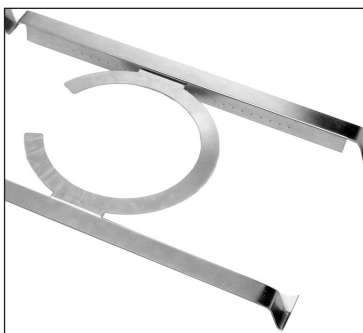

C-ring and support rails help distribute speaker assembly weight.



Plastic shield is included to protect driver if baffle is painted.



Use paper template to mark ceiling or wall cut-outs.

TECHNICAL DRAWINGS

Dimensions are inches and [mm] unless stated otherwise.

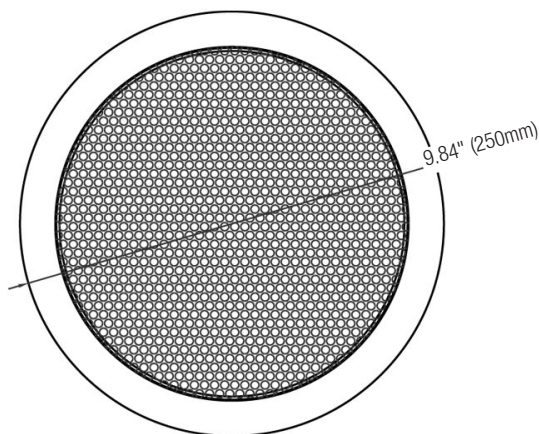

Cut-out is 8.875" (225mm)

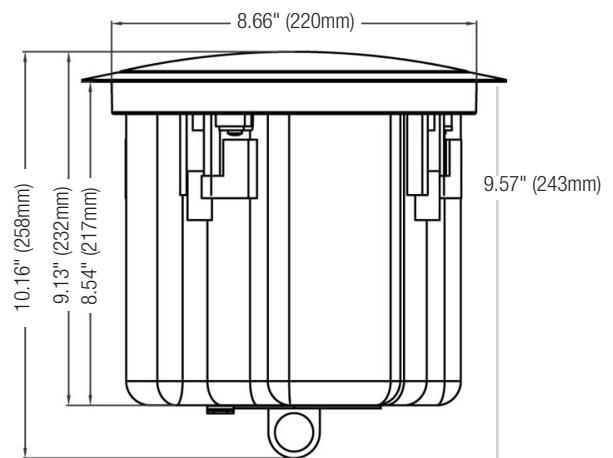

Note: If the seismic support ring is not used, an additional .42" (10.7mm) of rear clearance can be achieved by bending the ring over.

POLAR DATA

180 degrees (half space mounting)

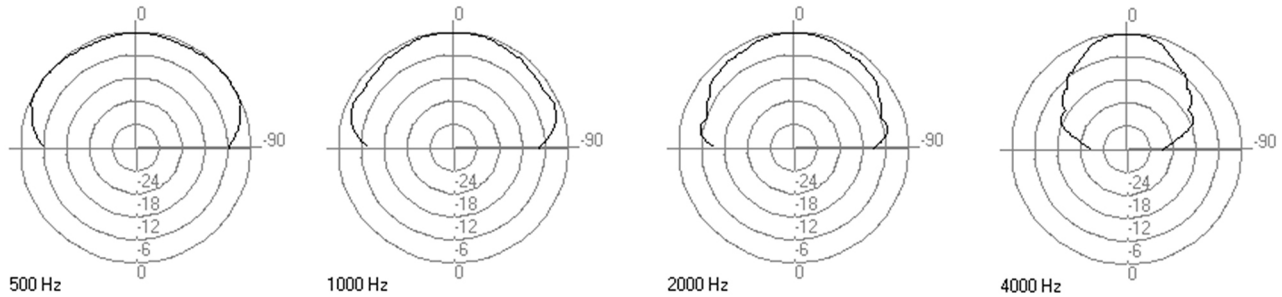

SPL VS. FREQUENCY (1W/1M)

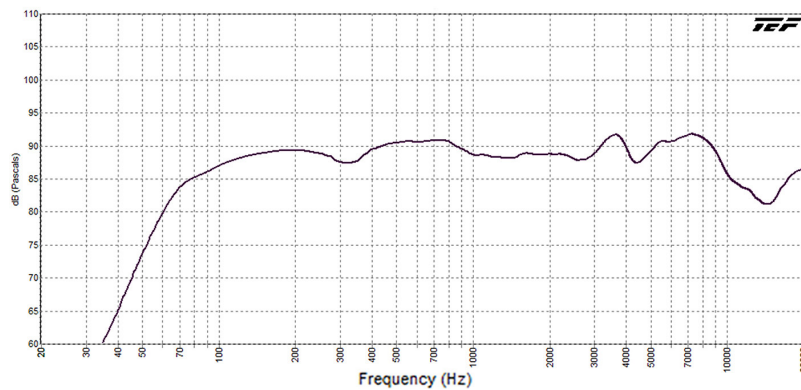

IMPEDANCE

Impedance reading expected from a typical 1kHz impedance meter is 9.5 ohms with the selector switch in the 8 ohm position.

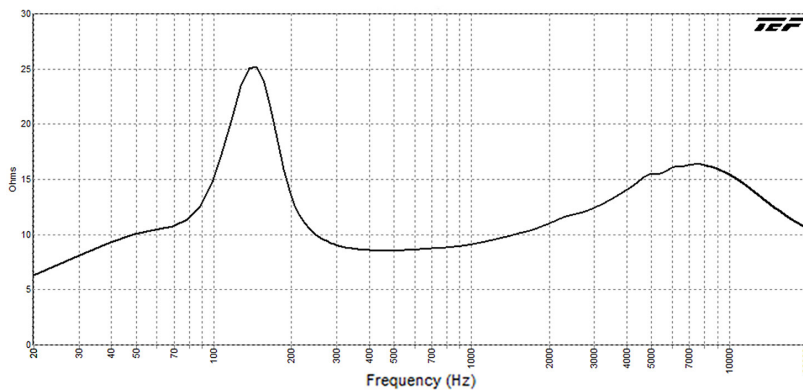

TEST METHODOLOGIES: Lowell speaker systems are thoroughly tested to provide specifiers and contractors with accurate data. Test equipment includes the GoldLine TEF-20 analyzer.

- **POWER HANDLING:** specification is based on E.I.A. Standard RS-426B.
- **FREQUENCY RESPONSE:** describes the usable response range defined by a ± 6 dB window, which is useful in predictive engineering calculations.
- **SENSITIVITY:** is a computer calculation of the log average sound pressure level (SPL) over the entire engineering bandwidth as given in the Frequency Response (± 6 dB).
- **MAXIMUM SPL:** is calculated based on the Power Handling and the measured log average Sensitivity where Maximum SPL = (Sensitivity @ 1W1M) + 10 log (Power Handling).
- **DISPERSION ANGLE:** is defined as the angle of coverage that is no more than 6dB down from the on-axis value averaged over the 2kHz octave band. Since speech intelligibility is dependent upon the 2kHz octave, this specification is useful in designing voice reinforcement and music systems that provide even coverage and intelligibility. The polar plots illustrate how the system performs when hung in free space (360°) or half-space (180°) in the case of a recessed speaker.

TECHNICAL DATA

PERFORMANCE:	Power Handling 30W RMS (at 8 ohms) measured per EIA Standard RS-426B
	Sensitivity 88.0 dB log average SPL (at 8 ohms) @1W/1M over the frequency response range, measured in half-space.
	Maximum SPL 102.8 dB (calculated based on power rating and measured 8 ohm sensitivity).
	Impedance 8 ohms (nominal), 8.5 ohms @ 508 Hz (min.)
	Frequency Response 70Hz – 20kHz (±6dB)
	Conical Dispersion Angle 165 degrees conical @2kHz octave (-6dB)
	Crossover Frequency 5kHz
	Transformer Taps 100V (16, 8, 4, 2W); 70V (16, 8, 4, 2, 1W); 25V (2, 1, .5, .25, .13W)
PHYSICAL (Full Range Speaker):	Woofer Cone Specially formulated polypropylene
	Surround Rubber
	Woofer Magnet Weight 10 oz. (283.5g)
	Woofer Voice Coil Dia. 1-inch (25.47mm)
	Tweeter Cone Mylar with acoustical lens
	Tweeter Magnet Weight 0.06 oz. (1.8g) neodymium magnet
	Tweeter Voice Coil Dia. 0.53 in. (13.5mm)
MECHANICAL:	Input Terminals 4-conductor removable Phoenix-style connector
	Net Weight (speaker & grille) . . 6.5 lbs. [2.95kg]
	Shipping Weight (pair) 20.4 lbs. [9.5kg]
MOUNTING:	C-ring One included per speaker
	Support Rail Two included per speaker

A&E SPECIFICATIONS

The loudspeaker shall be Lowell model ES-52T. It shall include a high-performance 5-1/4 inch coaxial loudspeaker, ported bass reflex enclosure and press-fit grille for recessed ceiling/wall installation. Frequency response shall be 70Hz-20kHz (±6dB). Average sensitivity for the system shall be 88.0dB @1W/1M over the frequency response range, measured in half-space. The speaker shall be constructed of a polypropylene cone with rubber surround and a Mylar tweeter. The woofer magnet weight shall be a minimum of 10 oz. (283.5g) and the woofer voice coil diameter shall be 1-inch (25.47mm). The transformer shall have primary taps for 100V (16, 8, 4, 2 watt); 70V (16, 8, 4, 2, 1 watt); and 25V (2, 1, .5, .25, .13 watt) with a selector switch mounted on the front under the grille that will include an 8 ohm transformer bypass position. The factory-mounted enclosure shall be 20-gauge steel (painted grey) with internal volume of 379 cu.in. It shall have a seismic restraint ring tie-point on the rear for use where required by code or ordinance. It shall feature four dog-mount ears that allow it to be mounted in a ceiling with a thickness of 0.1 in. (2.54mm) up to 1.4 in. (35.56mm). A template shall be provided to assist in cutting mounting holes. A rear access cable or flexible conduit entrance strain relief shall be provided with a termination cavity that encloses a four-pin Phoenix-style connector. The connector shall include two terminals for input to the speaker and two parallel terminals for output to the next speaker in the string. The system shall include a C-ring for use in reinforcing the edge of drywall ceiling cutouts, or for use with the included support rails to guard against ceiling tile sag from speaker weight. Front baffle shall have a diameter not more than 9.84 in. (249.9mm). The unit shall also include a press-fit, fine mesh 20-gauge CRS grille with UV rated powder epoxy coating (white), and shall include a thin piece of white scrim and grille-pulling tool.



ES SERIES OVERVIEW

Model No.	Driver	Transformer*	Overall Depth	Overall Diameter	Net Weight	Color	System Specs (measured half space)		
							Sensitivity**	Frequency Response	Dispersion***
ES-4T	4" 25W dual cone	16W	6.22"	8.27"	4.1 lbs.	white	85.7 dB	108Hz–20kHz (±6dB)	175°
THIS SPEC ES-52T	5-1/4" 30W coaxial	16W	10.16"	9.84"	6.5 lbs.	white	88.0 dB	70Hz–20kHz (±6dB)	165°
ES-62T	6-1/2" 50W coaxial	32W	10.16"	9.84"	7.5 lbs.	white	88.6 dB	64Hz–20kHz (±6dB)	120°
ES-82T	8" 120W coaxial	120W	11.03"	12.89"	14.6 lbs.	white	90.0 dB	64Hz–20kHz (±6dB)	105°
ES-82CDT	8" 150W coaxial compression	120W	11.03"	12.89"	18.0 lbs.	white	91.5 dB	67Hz–20kHz (±6dB)	70°
ES-8TSUB	8" 120W subwoofer	120W	11.03"	12.89"	16.6 lbs.	white	90.2 dB	57Hz–138Hz (±6dB)	omni-directional

* Includes transformer bypass position

** Average Sensitivity: SPL @ 1W/1M

*** Conical Dispersion @ 2kHz octave (-6dB)

Notes: Overall Depth includes grille and enclosure. Overall Diameter includes trim ring. Net Weight includes speaker, enclosure, grille (no installation aids). ES Speakers are sold in pairs.

Note on Speaker Spacing: Conical dispersion measurements are provided for comparison with other speakers. To determine correct speaker spacing, see the technical paper "Distributed System Speaker Spacing for the Integrator" (free download at www.Lowellmfg.com) which explains the difference between conical and linear dispersion and the measurements to use for best results. For quick calculations, a speaker spacing calculator is also available online under [Resources / Interactive Tools](#).