

CARVIN

audio



LT SERIES

POWER FACTOR CORRECTION
AUDIO AMPLIFIERS

INTRODUCTION

Carvin introduces three lightweight power amp models which provide pure amplification of the original source to extreme levels, covering all frequencies without added color. Each model features single space 1U frames, are 2 ohms capable, and include PFC Power Factor Correction, which is internationally recognized as the foremost self-regulating power supply for high-end amplifiers. Each power amp model has exceptional headroom with lower power requirements than amps with a traditional power supply.

LT MODELS

- » LT2000™ 2 Channel: 2x 340W RMS 8 ohms, 2x 580W RMS 4 ohms, 2x 1010W RMS 2 ohms, 1x 1180W RMS 8 ohms bridged or 1x 2010W RMS 4 ohms bridged for dual 18" subs.
- » LT5800™ 2 Channel for maximum headroom: 2x 1010W RMS 8 ohms, 2x 1690W RMS 4 ohms, 2x 2880W RMS 2 ohms, 1x 3380W RMS 8 ohms bridged or 1x 5760W RMS 4 ohms bridged.
- » LT5204™ 4 Channel for unlimited flexibility: 4x 440W RMS 8 ohms, 4x 780W RMS 4 ohms, 4x 1290W RMS 2 ohms, 2x 1520W RMS 8 ohms bridged, 2x 2575W RMS 4 ohms bridged. Typical set up: 2575W bridged for one 4 ohms dual 18" sub, plus 440W 8 ohms for L & R mains, or 2575W each for two dual 4 ohm 18" subs mono or stereo.

PFC POWER FACTOR CORRECTION

CARVIN has been building power amplifiers since 1976. Our experience results in advanced features like soft starting PFC Power Factor Correction, which corrects the incoming AC by synchronizing the AC voltage to the line current to reduce energy consumption and heat while producing substantially more power from the same AC input. Crystal clear transparency is provided by CLASS D output stages featuring linear circuits with a near theoretical zero distortion level. Fast slew rate 50V/μS circuits produce power at extreme levels delivering audio in its purest state with no added color.

ENGINEERING EXCELLENCE

Features include the 1U all steel 1.75" H X 19" W frames doubling rack amp capacities. Large output FETs deliver massive amounts of current without de-rating 4 ohm bridge and 2 ohm performance. 70V and 100V distribution systems are easily facilitated. Fail-safe features include variable speed cooling that draws cold air from the front while venting to the rear. All power ratings are for ambient temperatures up to 130° (54°C). AC voltages from 100-240VAC 50-60Hz are accommodated including unregulated generators. Custom



LT SERIES FEATURES

- » Active PFC Power Factor Correction
 - » Space saving lightweight 1-U frames
 - » High slew rate class D design
 - » Natural, pure-state amplification
 - » Up to 5760W, 1010W 8 ohms RMS
 - » 2 ohm operation, 4 ohm bridged design
 - » For 70V distribution systems
 - » Soft-Start 100-240VAC 50-60Hz
 - » PowerCON™ AC connector
 - » Front to rear cooling system
 - » IEC60065 compliant, CB certified
 - » Up to 12 LT amplifiers in one 12U rack case
- » The LT2000 2ch model delivers 340W RMS at 8 ohms, 580W at 4 ohms and 1010W at 2 ohms from each channel (2010W 4 ohms bridged).
 - » The LT5800 2ch model delivers 1010W RMS at 8 ohms, 1690W at 4 ohms and 2880W at 2 ohms from each channel (5760W 4 ohms bridged). Designed for the largest events with multiple subs, the LT5800 provides exceptional headroom for distortion-free performances.
 - » The LT5204 4ch model delivers 4x 440W RMS at 8 ohms, 4x 780W at 4 ohms and 4x 1290W at 2 ohms. The LT5204 may be configured into two bridged outputs to deliver 2575W into two bridged 4 ohms loads.

AC cables may be connected to the PowerCON™ connector replacing the factory heavy-duty cable. The safety certification includes the international CB™ mark. CARVIN's LT Series™ professional amplifiers offer technological advancements beyond the common power amp, providing the purest audio at the highest levels.

WARRANTY

This CARVIN product is guaranteed to be free from electrical and mechanical defects for a period of one year from date of purchase. Retain proof of purchase. This warranty is in lieu of any and all other guarantees or warranties expressed or implied. There shall be no recovery for any consequential or incidental damages.

LT2000



LT5800



LT5204

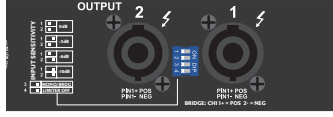

Model		LT2000	LT5800	LT5204
 <p>All ratings 1kHz 20ms</p>	8Ω/Stereo	2 x 340W	2 x 1010W	4 x 440W
	4Ω/Stereo	2 x 580W	2 x 1690W	4 x 780W
	2Ω/Stereo	2 x 1010W	2 x 2880W	4 x 1290W
	8Ω/Bridge	1 x 1180W	1 x 3380W	2 x 1520W
	4Ω/Bridge	1 x 2010W	1 x 5760W	2 x 2575W
70Vrms (70V Distribution Systems) Bridge Mode		1 x 900W	1 x 2300W	2 x 900W
Slew rate: bridged mode:		50V/μS		
Input Sensitivity Settings @8Ω		.97vrms(+2dBu)	1.2vrms(+4dBu)	1.95vrms(+8dBu) 3vrms(+12dBu)
THD (10% rated power, typical)		0.02%	0.02%	0.02%
Frequency Response (20-20kHz, 8Ω)		±0.2dB		
Input Impedance		20kΩ Balanced, 10kΩ Unbalanced		
Damping Factor		≥5000		
Signal to Noise Ratio		≥ 105dB	≥ 108dB	≥ 99dB
AC Input		100-240VAC 50-60Hz		
Protection Circuits:		Under Voltage, DC, Thermal, Overload, Short Circuit, Limiter		
Ambient Temperature Range		20°F - 130°F		
Dimensions		19"W x 14.56"D x 1.73"H		
Net Weight		19.8 lb	22.4 lb	22.4 lb

BALANCED XLR INPUT CONNECTION

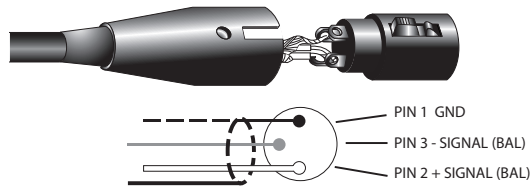

UNBALANCED XLR INPUT CONNECTION

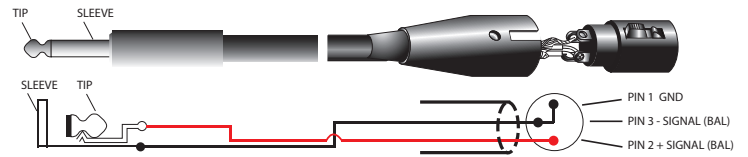

TWIST LOCK SPEAKER CABLE ASSEMBLY

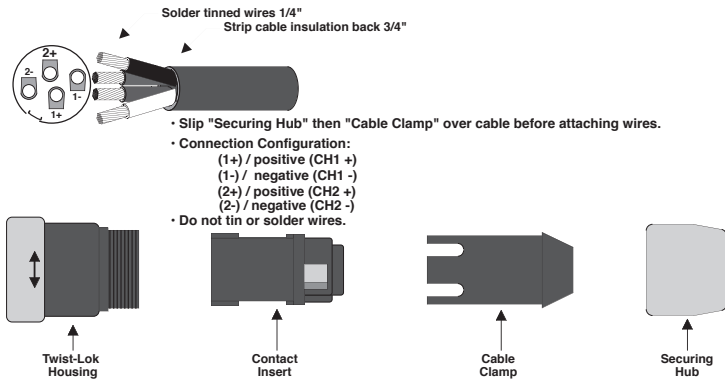

» Actual color of individual wire conductors may vary depending on cable manufacturer.

AIR FLOW DIRECTION

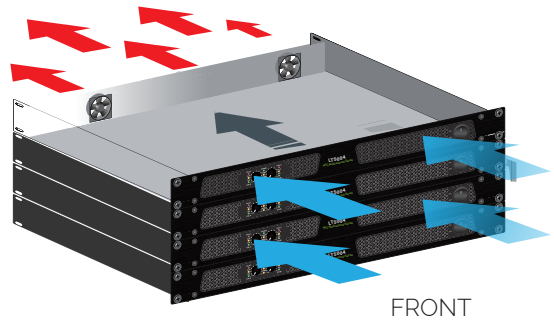

» For proper cooling make sure front panel has access to cool air and the rear panel maintains a minimum of 18-inches clearance from any wall or obstruction.

STEREO MODE - 2 CONDUCTOR CABLE

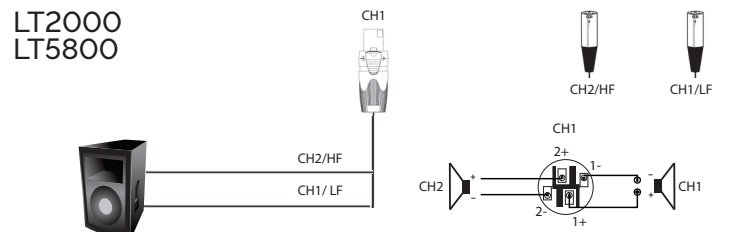
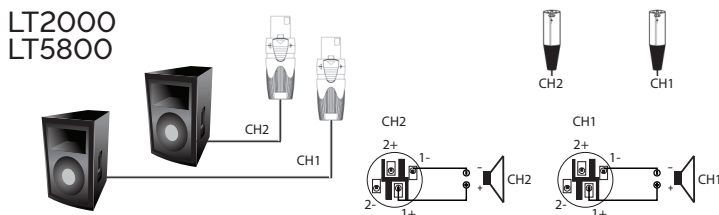
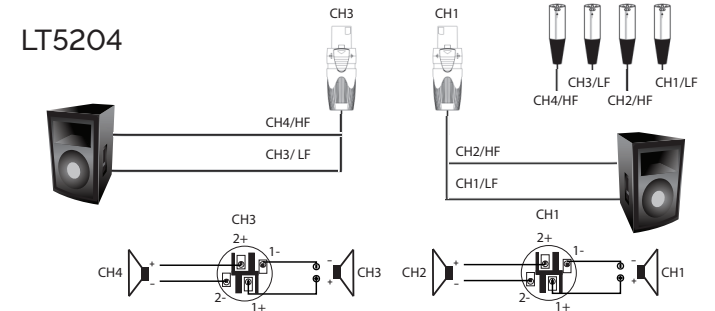
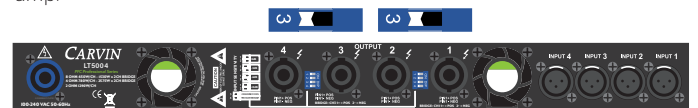
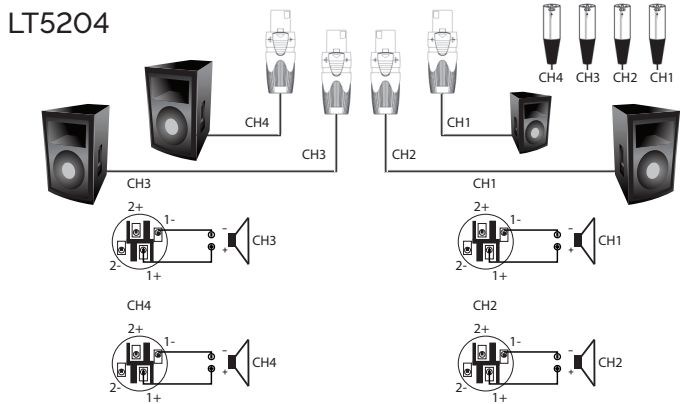

MONO/BRIDGE MODE

CH 3 & 4 CH 1 & 2



LT5204

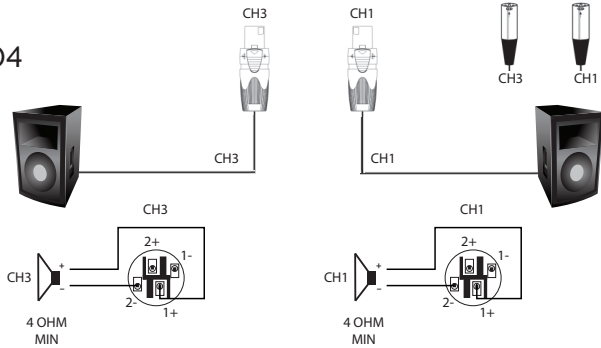

3 CHANNEL



LT5800
LT2000

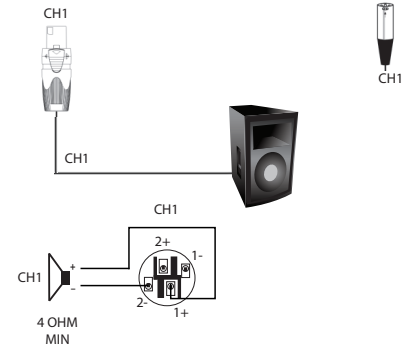

STEREO/2WAY
CH 3 & 4

MONO BRIDGE
CH 1 & 2



LT5204

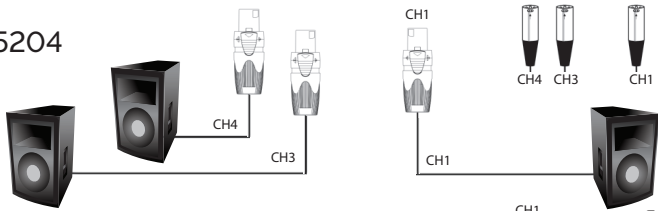

SUBWOOFER

AMPLIFIER DIMENSIONS

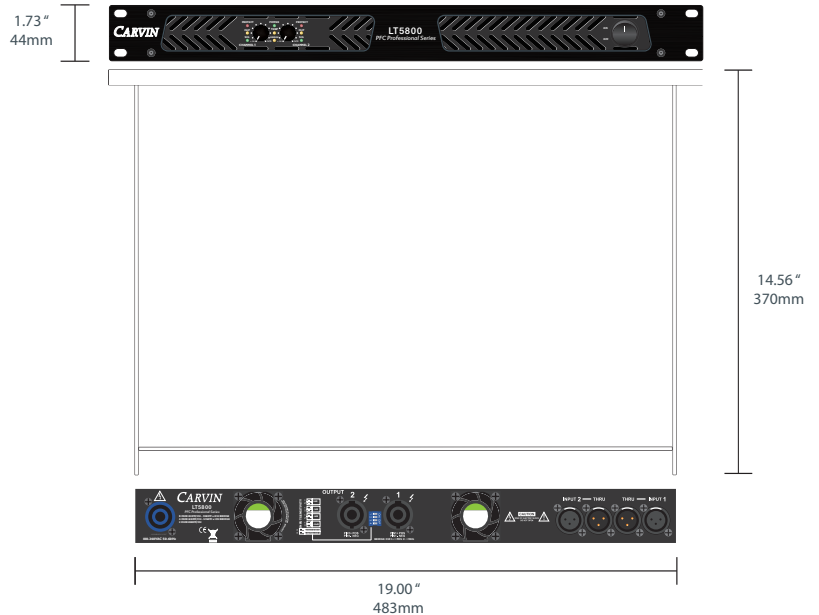

PowerCON™ WIRING

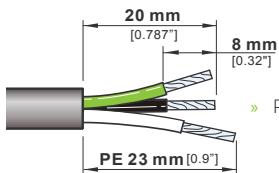

» Prepare the cable as shown.

» Insert the wire into the terminal and fasten the clamping device with a Phillips screwdriver. Do not tin or solder wires.

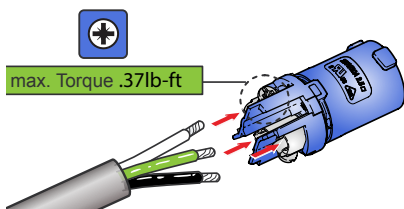

120V/240VAC
WIRING

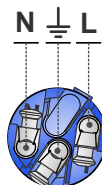

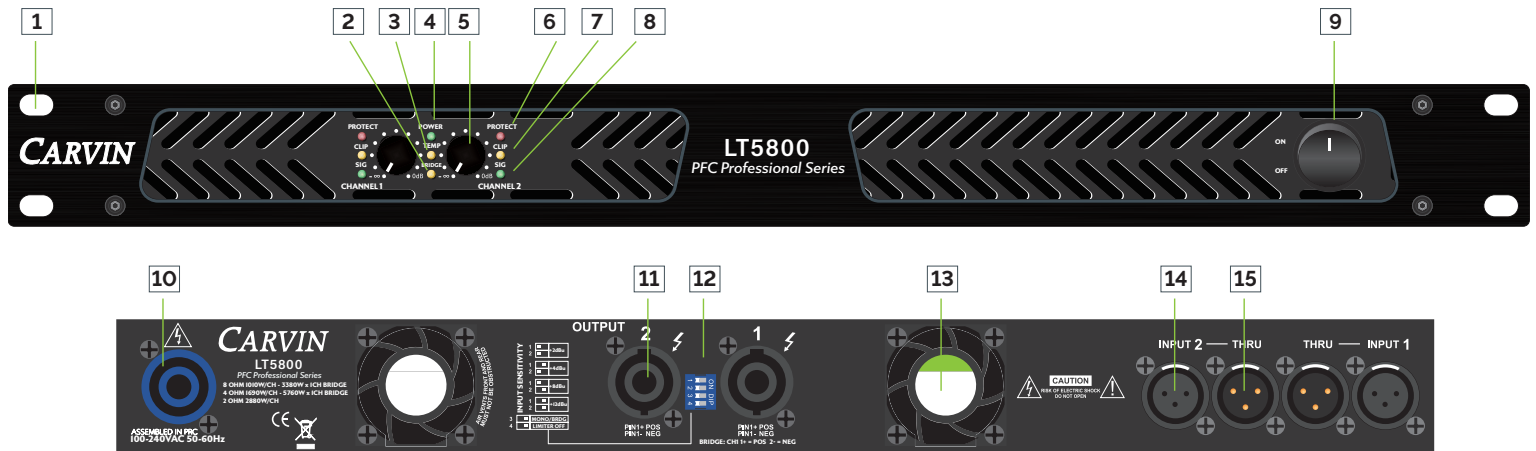

LT SERIES OPERATION

- » **1. MOUNTING:** Heavy duty one piece 8mm aluminum face plate accommodates standard 19" rack installation. The rack mounting holes are designed on ISO standard spacing. Eight 10-32x.75" Phillips machine screws are normally used to secure the amp to the front and rear of the gear rack. All LT amplifiers are 14.6-inches deep
- » **2. BRIDGE MODE:** With your amp off, slide the #3 dip switch (#12) on the rear of the amplifier to the right to enter into BRIDGE MODE. The LT5204 can be run with both channel pairs in bridge mode giving you two high powered output channels, or the LT5204 can be configured to run with one pair of channels in bridge mode and the other pair of channels in stereo, giving you a 3 Channel amplifier with one high powered channel for your subwoofer and two channels for your MID/HI connections (when tri-amping), or your LEFT/RIGHT speakers (Stereo). Refer to the SET UP wiring diagrams on page 5 for speaker cable configuration. **WARNING:** No other speaker connectors may be used at the same time when in bridge mode! Use Channel 1 INPUT and LEVEL for bridge mode (CH1&3 on LT5024). The minimum speaker impedance is 4 ohms.
- » **3. TEMP:** The yellow TEMP LED will illuminate when the internal operating temperature exceeds the safe operating limit of the amplifier and the temperature protection is activated. When activated, the power output of the amplifier is reduced, allowing the internal amplifier temperature to return to the safe operating range while still producing audio. The TEMP LED can be triggered prematurely by the following conditions: A) The front intake air is restricted, B) The intake air is extremely warm, C) The rear exhaust fans and vents are restricted or less than 18-inches from a wall, not allowing the hot air to escape, or D) Operation below rated minimum impedance.
- » **4. POWER:** The green POWER LED indicates that all circuits are properly powered up.
- » **5. CHANNEL LEVEL CONTROL:** Precision input LEVEL attenuators are used to adjust the volume levels. To deliver the amp's maximum power without reducing the headroom of the signal source, the level controls should be turned full on.
- » **6. PROTECT:** The red PROTECT LED will illuminate when the output load draws excessive current or a direct short is detected caused by a shorted speaker cable or speaker system. Reset this condition by turning the amp off for two seconds and then on again. Check for shorted cables and that the total speaker impedance is not below 2 ohms per channel or 4 ohms bridged.
- » **7. CLIP:** The yellow CLIP LED indicators flash when each channel has reached its maximum clean output. Occasional flashing caused by low frequency peaks are normal and will not harm speakers capable of handling the amplifier's output. However, consistent flashing (excessive clipping/square wave) will damage speakers if not reduced. This does not cause damage to the amp.
- » **8. SIGNAL:** The green SIGNAL LED indicates that an audio signal is present on the channel.
- » **9. POWER ON/OFF:** Turns the amplifier on and off. Check the power amp AC making sure the rear plug is fully inserted before engaging the power switch. The green POWER LED (#4) indicates that all circuits are properly powered up.
- » **10. AC POWER:** Your amp is designed to work with 100-240VAC 50-60Hz using a PowerCON™ AC receptacle. Included with your amplifier is a heavy duty PowerCON™ power cable with an EDISON plug. Amplifiers in use outside of North American will need to replace the EDISON plug with the local connector. To replace the PowerCON™ connector see page 5 for the wiring diagram. Check local laws and regulations. Be sure to check your power source before plugging into a grounded (3 prong) outlet.

- » **11. SPEAKER OUTPUT:** Twist-Lock connectors are featured for high power applications. Secure the Twist-Lock cable connection by turning to the right to the lock position. Twist-Lock outputs are compatible with standard 2-conductor Twist-Lock cables. A 4-conductor Twist-Lock cable will enable bi-amping with one 4 conductor cable. See Bi-amping on page 4.
- 70V DISTRIBUTION SYSTEM:** For distribution systems, you may connect a number of speakers with 70V transformers (in parallel) to the output of the amplifier. Transformer speakers usually have selections of 5, 10, 15, or 20 watts. To calculate the number of speakers that can be connected to an amplifier, divide the output wattage of the amplifier by the speaker wattage selected. Example: 900W/20W = 45 speakers. The LT2000 delivers 900W x 1, The LT5204 delivers 900W x 2 and the LT5800 delivers 2300W x 1. Speakers can be set to different wattages so use the average wattage of all the speakers as one number. Another advantage of a distribution system is the reduction of the wire size to drive a number of speakers.
- 12. SENSITIVITY / AMPLIFIER MODES:** The blue DIP switch cluster on the rear panel allows the user to make the following adjustments. 1. Amplifier sensitivity. 2. Stereo/Bridge Mode. 3. Limiter.

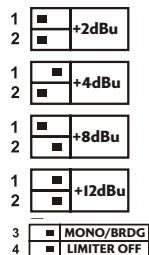

1 & 2. Amplifier Sensitivity adjustments allow you to decide how much input signal is required to achieve full power output from the amplifier. The lower the +dBu number, the more sensitive the amplifier becomes. To change the sensitivity, move the dip switches labeled 1 & 2 to the correct orientation as shown on the diagram.

3. To engage MONO/BRIDGE mode, move the dip switch labeled 3 to the right position.

4. LIMITER. Designed to protect against distortion, the limiter automatically reduces the signal to prevent hard clipping, which helps protect the drivers. It is recommended to keep the limiter ON. To turn the limiter off, move the dip switch labeled 4 to the right position.

13. COOLING FANS: The variable speed cooling fans are designed to draw cold air from the front panel and exhaust the heat from the rear panel. Maintain a minimum of 18-inches clearance from the rear wall when using for high powered applications. Inadequate ventilation will activate the thermal protection prematurely. The front cooling vents are not to be restricted.

» **14 & 15 CHANNEL INPUTS:** The XLR balanced inputs will help reduce signal interference and allow longer cable runs from your signal source (mixer, etc). XLR pin configuration: Pin 1: ground, Pin 2: positive balanced signal, Pin 3: negative balanced signal. The THRU XLR connector passes the input signal out for connection to another amplifier's input (except for LT5204).