

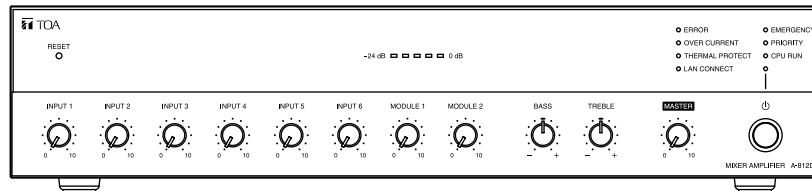

OPERATING INSTRUCTIONS

800D SERIES MIXER AMPLIFIER

A-812D, A-824D, A-848D



The figure represents the A-812D.

Note on Firmware Upgrade

Before using the device, upgrade the firmware.

The latest firmware can be downloaded from the product page of the A-812D, A-824D, A-848D on the TOA Corporation website.

Thank you for purchasing TOA's 800D Series Mixer Amplifier.

Please carefully follow the instructions in this manual to ensure long, trouble-free use of your equipment.

TABLE OF CONTENTS

1. IMPORTANT SAFETY INSTRUCTIONS	3
2. SAFETY PRECAUTIONS	4
3. GENERAL DESCRIPTION	6
4. FEATURES	6
5. HANDLING PRECAUTIONS	6
6. INSTALLATION PRECAUTIONS	7
7. THE DUCKER FUNCTION AND THE PRIORITY BROADCAST FUNCTION	7
8. NOMENCLATURE AND FUNCTIONS	8
Front	8
Rear	9
9. CONNECTIONS	12
9.1. Speaker Connection	12
9.2. Input Terminal Connections and Settings	13
9.3. Connecting to the Remote Master Volume Control Terminal	15
9.4. Connecting to the Power Remote Control Output Terminal	15
9.5. Connecting to the Emergency Control Output Terminal	16
9.6. Connecting to the Control Input Terminal	16
9.7. Connecting the External Equipment between the Pre-amplifier Output and the Power Amplifier	17
9.8. Removable Terminal Plug Connection	18
10. SETTINGS	19
10.1. Chime Tone Setting	19
10.2. Module Setting	19
11. DUCKER DEPTH ADJUSTMENT	20
12. VOLUME ADJUSTMENT	20
13. INSTALLING TO AN EQUIPMENT RACK	21
14. CONTROL SETTINGS	21
15. PRIORITY BROADCAST FUNCTION	22
15.1. Priority Broadcast	22
15.2. Priority Broadcast Mode	22
15.3. Emergency Broadcast	23
15.4. Normal Broadcast	23
15.5. Relationship between the Priority/Emergency Broadcasts and the Power On/Off State	23
15.6. Factory Default Settings	24
16. SETTINGS ON THE BROWSER	25
17. BLOCK DIAGRAM	26
18. SPECIFICATIONS	27
Accessories	28
Optional product	28

1. IMPORTANT SAFETY INSTRUCTIONS

- Read these instructions.
- Keep these instructions.
- Heed all warnings.
- Follow all instructions.
- Do not use this apparatus near water.
- Clean only with dry cloth.
- Do not block any ventilation openings. Install in accordance with the manufacture's instructions.
- Do not install near any heat sources such as radiators, heat registers, stoves, or other apparatus (including amplifiers) that produce heat.
- Do not defeat the safety purpose of the polarized or grounding-type plug. A polarized plug has two blades with one wider than the other. A grounding type plug has two blades and a third grounding prong. The wide blade or the third prong are provided for your safety. If the provided plug does not fit into your outlet, consult an electrician for replacement of the obsolete outlet.
- Protect the power cord from being walked on or pinched particularly at plugs, convenience receptacles, and the point where they exit from the apparatus.
- Only use attachments/accessories specified by the manufacturer.
- Use only with the cart, stand, tripod, bracket, or table specified by the manufacturer, or sold with the apparatus. When a cart is used, use caution when moving the cart/apparatus combination to avoid injury from tip-over.



- Unplug this apparatus during lightning storms or when unused for long periods of time.
- Refer all servicing to qualified service personnel. Servicing is required when the apparatus has been damaged in any way, such as power-supply cord or plug is damaged, liquid has been spilled or objects have fallen into the apparatus, the apparatus has been exposed to rain or moisture, does not operate normally, or has been dropped.

INSTRUCTIONS ESSENTIELLES POUR LA SÉCURITÉ

- Lire ces instructions.
- Conserver ces instructions pour référence ultérieure.
- Respecter tous les avertissements.
- Suivre toutes les instructions.
- Ne pas utiliser cet appareil à proximité d'eau.
- Nettoyer uniquement à l'aide d'un chiffon sec.
- Ne pas obstruer les orifices de ventilation. Installer conformément aux instructions du fabricant.
- Ne pas installer à proximité de sources de chaleur telles que des radiateurs, des registres thermiques, des chaudières ou d'autres appareils (notamment des amplificateurs) produisant de la chaleur.
- Ne pas contourner la fonction de sécurité de la fiche polarisée ou de mise à la terre. Une fiche polarisée est équipée de deux broches, dont l'une est plus large que l'autre. Une fiche de mise à la terre est équipée de deux broches et d'une troisième pour la mise à la terre. Cette dernière, la plus large, est prévue à des fins de sécurité. Si la fiche fournie ne peut être insérée dans la prise électrique souhaitée, consulter un électricien pour faire remplacer cette dernière.
- Protéger le cordon d'alimentation pour éviter qu'il ne soit piétiné ou pincé, notamment au niveau des fiches, des prises de courant ou de son point de sortie de l'appareil.
- Utiliser uniquement les accessoires spécifiés par le fabricant.
- Utiliser uniquement avec le chariot, support, trépied, la patte de montage ou la table spécifiés par le fabricant ou vendus avec l'appareil. En cas d'utilisation d'un chariot, manipuler la combinaison chariot/appareil pour éviter les blessures dues à un renversement.



- Débrancher cet appareil pendant les orages ainsi que lorsqu'il reste inutilisé pendant une période prolongée.
- La maintenance de l'appareil doit être confiée à un technicien après-vente qualifié. Une maintenance s'avère nécessaire si l'appareil est endommagé (au niveau du cordon d'alimentation ou de la fiche), a été mouillé par un liquide, un objet est tombé à l'intérieur, s'il a été exposé à la pluie ou l'humidité, s'il ne fonctionne pas normalement ou s'il est tombé.

2. SAFETY PRECAUTIONS

- Before installation or use, be sure to carefully read all the instructions in this section for correct and safe operation.
- Be sure to follow all the precautionary instructions in this section, which contain important warnings and/or cautions regarding safety.
- After reading, keep this manual handy for future reference.

Safety Symbol and Message Conventions

Safety symbols and messages described below are used in this manual to prevent bodily injury and property damage which could result from mishandling. Before operating your product, read this manual first and understand the safety symbols and messages so you are thoroughly aware of the potential safety hazards.



WARNING

Indicates a potentially hazardous situation which, if mishandled, could result in death or serious personal injury.

When Installing the Unit

- Do not expose the unit to rain or an environment where it may be splashed by water or other liquids, as doing so may result in fire or electric shock.
- Use the unit only with the voltage specified on the unit. Using a voltage higher than that which is specified may result in fire or electric shock.
- Do not cut, kink, otherwise damage nor modify the power supply cord. In addition, avoid using the power cord in close proximity to heaters, and never place heavy objects -- including the unit itself -- on the power cord, as doing so may result in fire or electric shock.
- Be sure to ground to the safety ground (earth) terminal to avoid electric shock. Never ground to a gas pipe as a catastrophic disaster may result.
- Avoid installing or mounting the unit in unstable locations, such as on a rickety table or a slanted surface. Doing so may result in the unit falling down, causing personal injury and/or property damage.
- Since the unit is designed for indoor use, do not install it outdoors. If installed outdoors, the aging of parts causes the unit to fall off, resulting in personal injury. Also, when it gets wet with rain, there is a danger of electric shock.
- The terminals marked with the symbol  are hazardous live. The external wiring to these terminals requires installation by an instructed person.

When the Unit is in Use

- Should the following irregularity be found during use, immediately switch off the power, disconnect the power supply plug from the AC outlet and contact your nearest TOA dealer. Make no further attempt to operate the unit in this condition as this may cause fire or electric shock.
 - If you detect smoke or a strange smell coming from the unit.
 - If water or any metallic object gets into the unit
 - If the unit falls, or the unit case breaks
 - If the power supply cord is damaged (exposure of the core, disconnection, etc.)
 - If it is malfunctioning (no tone sounds.)
- To prevent a fire or electric shock, never open nor remove the unit case as there are high voltage components inside the unit. Refer all servicing to your nearest TOA dealer.
- No objects filled with liquids, such as vases, shall be placed on the unit. If they accidentally spill into the unit, this may cause a fire or electric shock.
- Do not insert nor drop metallic objects or flammable materials in the ventilation slots of the unit's cover, as this may result in fire or electric shock.
- Do not touch a power supply plug during thunder and lightning, as this may result in electric shock.



CAUTION

Indicates a potentially hazardous situation which, if mishandled, could result in moderate or minor personal injury, and/or property damage.

When Installing the Unit

- Never plug in nor remove the power supply plug with wet hands, as doing so may cause electric shock.
- When unplugging the power supply cord, be sure to grasp the power supply plug; never pull on the cord itself. Operating the unit with a damaged power supply cord may cause a fire or electric shock.

- When moving the unit, be sure to remove its power supply cord from the wall outlet. Moving the unit with the power cord connected to the outlet may cause damage to the power cord, resulting in fire or electric shock. When removing the power cord, be sure to hold its plug to pull.
- Do not block the ventilation slots in the unit's cover. Doing so may cause heat to build up inside the unit and result in fire. Also, periodically clean the ventilation slots of dust.
- Avoid installing the unit in humid or dusty locations, in locations exposed to the direct sunlight, near the heaters, or in locations generating sooty smoke or steam as doing otherwise may result in fire or electric shock.
- Rack-mounting screws are not supplied with the unit. Prepare them that are appropriate for the equipment rack.
- Do not place heavy objects on the unit as this may cause it to fall or break which may result in personal injury and/or property damage. In addition, the object itself may fall off and cause injury and/or damage.
- Make sure that the volume control is set to minimum position before power is switched on. Loud noise produced at high volume when power is switched on can impair hearing.
- Do not operate the unit for an extended period of time with the sound distorting. Doing so may cause the connected speakers to heat, resulting in a fire.

When the Unit is in Use

- To avoid electric shocks, be sure to switch off the unit's power when connecting speakers.
- Be sure to follow the instructions below when rack-mounting the unit. Failure to do so may cause a fire or personal injury.
 - Install the equipment rack on a stable, hard floor. Fix it with anchor bolts or take other arrangements to prevent it from falling down.
 - When connecting the unit's power cord to an AC outlet, use the AC outlet with current capacity allowable to the unit.
- Contact your TOA dealer as to the cleaning. If dust is allowed to accumulate in the unit over a long period of time, a fire or damage to the unit may result.
- If dust accumulates on the power supply plug or in the wall AC outlet, a fire may result. Clean it periodically. In addition, insert the plug in the wall outlet securely.
- Switch off the power, and unplug the power supply plug from the AC outlet for safety purposes when cleaning or leaving the unit unused for 10 days or more. Doing otherwise may cause a fire or electric shock.

ATTENTION

L'appareil ne doit pas être exposé aux éclaboussures ou écoulements et tous objets remplis de liquide, tels que vases, ne doivent pas être sur l'appareil.

- The socket-outlet shall be installed near the equipment and the plug (disconnecting device) shall be easily accessible.
- The apparatus shall be connected to a mains socket outlet with a protective earthing connection.



The lightning flash with arrowhead symbol, within an equilateral triangle, is intended to alert the user to the presence of uninsulated "dangerous voltage" within the product's enclosure that may be of sufficient magnitude to constitute a risk of electric shock to persons.



The exclamation point within an equilateral triangle is intended to alert the user to the presence of important operating and maintenance (servicing) instructions in the literature accompanying the appliance.



L'éclair accompagné d'un symbole représentant une pointe de flèche à l'intérieur d'un triangle équilatéral avertit l'utilisateur de la présence d'une "tension dangereuse" à l'intérieur de l'enceinte du téléviseur, dont la magnitude peut être suffisante pour constituer un risque de choc électrique pour les personnes.



Le point d'exclamation à l'intérieur d'un triangle équilatéral avertit l'utilisateur de l'existence d'instructions d'utilisation et d'entretien (réparation) dans la documentation fournie avec l'appareil.

3. GENERAL DESCRIPTION

TOA's 800D Series mixer amplifier is a PA amplifier equipped with 4 microphone inputs, 2 auxiliary inputs, and 2 slots dedicated to the 900 Series modules. It employs a PFC circuit. It also features the following functions: Volume control function, Priority function, Chime function, and Remote confirmation function.

In addition, it is equipped with a 2-channel input BUS of AUDIO and DUCK, and the signal processing function. The 800D Series mixer amplifier is ideal for paging announcement and BGM applications in schools, offices, and super markets.

4. FEATURES

- 3 kinds of power amplifier outputs: 120 W (A-812D), 240 W (A-824D), and 480 W (A-848D)
- Lightweight owing to the built-in digital power amplifier unit
- Emergency broadcast and priority broadcast activated by way of the control input (contact)
- Voice detection function that allows the priority broadcast to be activated by voice
- Priority setting function
- Remote confirmation function that allows you to confirm the unit's status through the web browser using a PC
- Switchable speaker output ("4 Ω" or "70 V line")
- Module slots provided for mounting up to 2 units of 900 Series modules
- Electronically-balanced 4 microphone inputs (MIC 1 to MIC 4) with Input setting switches
- Fine sound adjustment possible by connecting a signal processor like an equalizer between the pre-amplifier output and the power amplifier input
- Bass and treble tone control knobs
- Output level meter
- Master volume control knob to simultaneously adjust all input levels
- Remotely controllable master volume
- Built-in chime unit (1-note chime, 2-note chime, and ascending 4-note chime)
- Equipped with the following signal processing functions:
Dynamic feedback filters, Equalizer (3 points), Gate, Software volume, Limiter, and Ducker

5. HANDLING PRECAUTIONS

- In this system, settings and control of the unit are performed on a PC via LAN (Local area network). It is not possible to perform them via the Internet.
- Some operations differ depending on this unit's power ON/OFF state. The table below shows the relationship between the power ON/OFF state and the corresponding operation.

Power state	LED lighting state		Normal broadcast		Priority broadcast/ Emergency broadcast	Web access
		CPU RUN	From Speaker output	From Recording output		
Not energized	Unlit	Unlit	Disabled	Disabled	Disabled	Disabled
Energized (Power turned OFF)	Unlit	Lit	Disabled	Disabled	Occasionally possible (Power is temporarily turned ON.)	Enabled
Energized (Power turned ON)	Lit	Lit	Enabled	Enabled	Enabled	Enabled

6. INSTALLATION PRECAUTIONS

- The supplied power supply cord is designed for exclusive use with the unit. Never use it with other equipment.
- Install the unit in a well-ventilated environment so that temperature inside the unit will not rise.
- When installing the unit on the desk, keep the unit over 10 cm (3.94") away from objects that may obstruct air flow as shown below.
- When installing the unit in an equipment rack, mount perforated panels. Refer to "INSTALLING TO AN EQUIPMENT RACK" on p. 21.

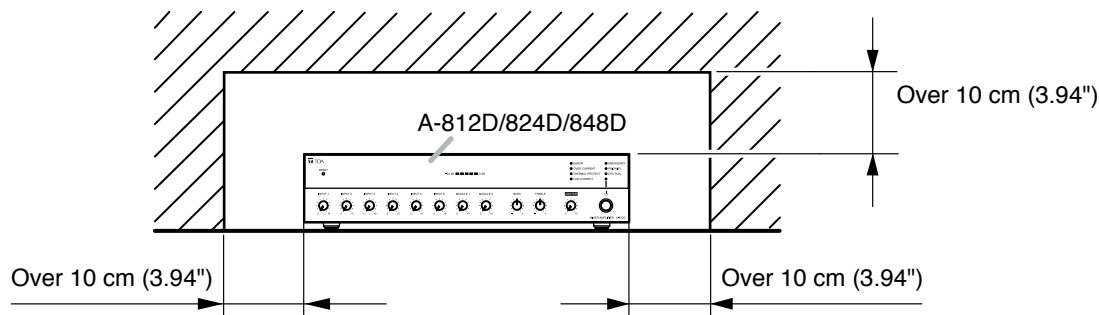

7. THE DUCKER FUNCTION AND THE PRIORITY BROADCAST FUNCTION

This unit is provided with Ducker function and Priority broadcast function that decrease the output level of other broadcasts while a specific broadcast is being made.

A Ducker function refers to the function to place a priority order between the audio signal groups divided into 2 groups. Use this function to make a simple usage such as to decrease the BGM level when making microphone announcement while the BGM broadcast is in progress.

For the details of the Ducker function, refer to "DUCKER DEPTH ADJUSTMENT" on p. 20.

A Priority broadcast function is the function to assign one of 8 priority levels to each broadcast content. Use this function to make a complicated usage compared with the Ducker function such as to select the audio signal to mute.

For the details of the Priority broadcast function, refer to "PRIORITY BROADCAST FUNCTION" on p. 22.

8. NOMENCLATURE AND FUNCTIONS

[Front]

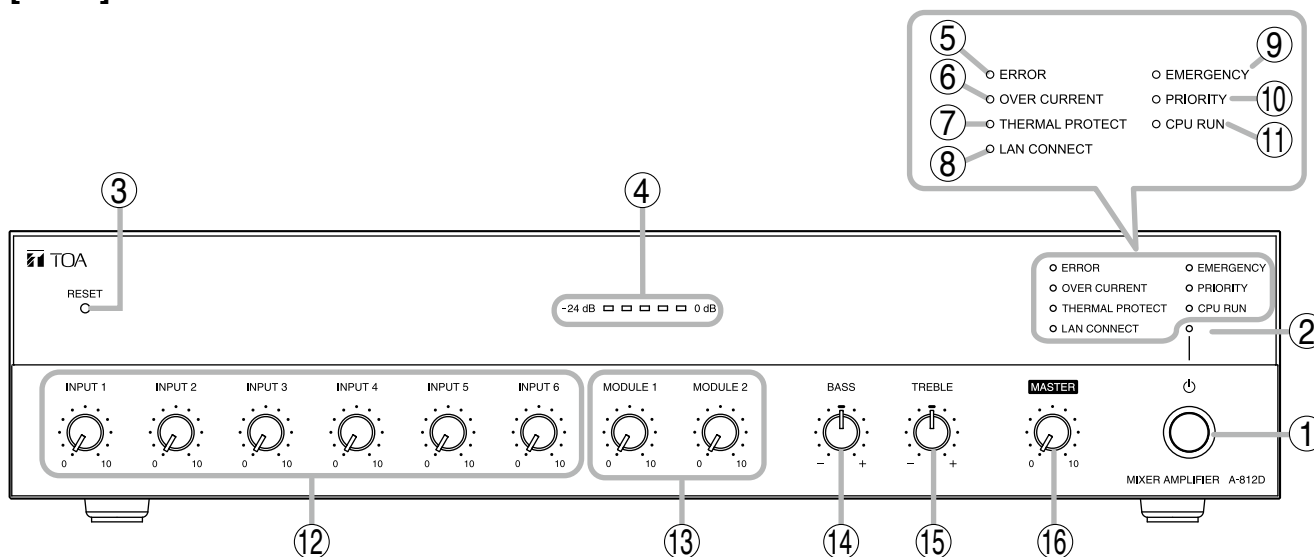

The figure represents the A-812D.

1. Power switch

Press this switch to turn on the power. To turn off the power, press this switch again.

Note

The power switch is disabled while the priority broadcast or the emergency broadcast is in progress.

2. Power indicator (Green)

Lights when the power is switched on and goes off when it is switched off.

3. Reset key

Press this key for 1 second or more to reset the unit.

Use a fine-tipped object to press in this switch.

Note

Perform the following steps before pressing the Reset key.

- Turn all volume knobs fully counterclockwise to minimize the volume value.
- Confirm that both the Priority broadcast indicator (9) and the Emergency broadcast indicator (10) are unlit.
- Press the Power switch (1) to turn it OFF.

4. LED level meter (Green x 3, Orange x 1, Red x 1)

Displays the output level.

Adjust each volume control knob for an appropriate output sound so that the red indicator does not light.

Operating the unit while the red indicator remains lit causes the sound quality to degrade.

5. Error indicator (Red)

Lights when the unit's internal abnormality has occurred.

6. Overcurrent protection indicator (Red)

Lights while the overcurrent protection circuit is operating if overcurrent flows through the speaker output.

7. Thermal protection indicator (Red)

Lights while the thermal protection circuit is operating.

8. Network connection confirmation indicator (Green)

An indicator to identify the unit using a web browser.

- Flashes for 5 seconds when the identification confirmation is performed using a web browser.
- Flashes 3 times when the unit is started up.
- Lights when in the manual mode.

(See the separate setup manual, which can be downloaded from the TOA DATA Library (<https://www.toa-products.com/international/>.)

9. Emergency broadcast indicator (Red)

Lights while the emergency broadcast is in progress.

(See "PRIORITY BROADCAST FUNCTION" on p. 22.)

10. Priority broadcast indicator (Green)

Lights while the priority broadcast is in progress.

(See "PRIORITY BROADCAST FUNCTION" on p. 22.)

11. CPU running indicator (Green)

Lights while the CPU is running.

12. Volume control knobs for Inputs 1 through 6

Adjust the volume values of the Inputs 1 through 6. Rotate each knob clockwise to increase the volume value and counterclockwise to decrease it. (See "VOLUME ADJUSTMENT" on p. 20.)

13. Volume control knobs for Module inputs 1 and 2

Adjust the volume values of the rear-mounted modules. Rotate each knob clockwise to increase the volume value and counterclockwise to decrease it.

14. Bass control knob

Rotate the knob clockwise to boost the bass and counterclockwise to cut it. Setting the knob at the center makes the frequency characteristic flat.

15. Treble control knob

Rotate the knob clockwise to boost the treble and counterclockwise to cut it. Setting the knob at the center makes the frequency characteristic flat.

16. Master volume control knob

Adjusts all the volume levels simultaneously. Rotate the knob clockwise to increase the whole volume level and counterclockwise to decrease it. (See "VOLUME ADJUSTMENT" on p. 20.)

[Rear]

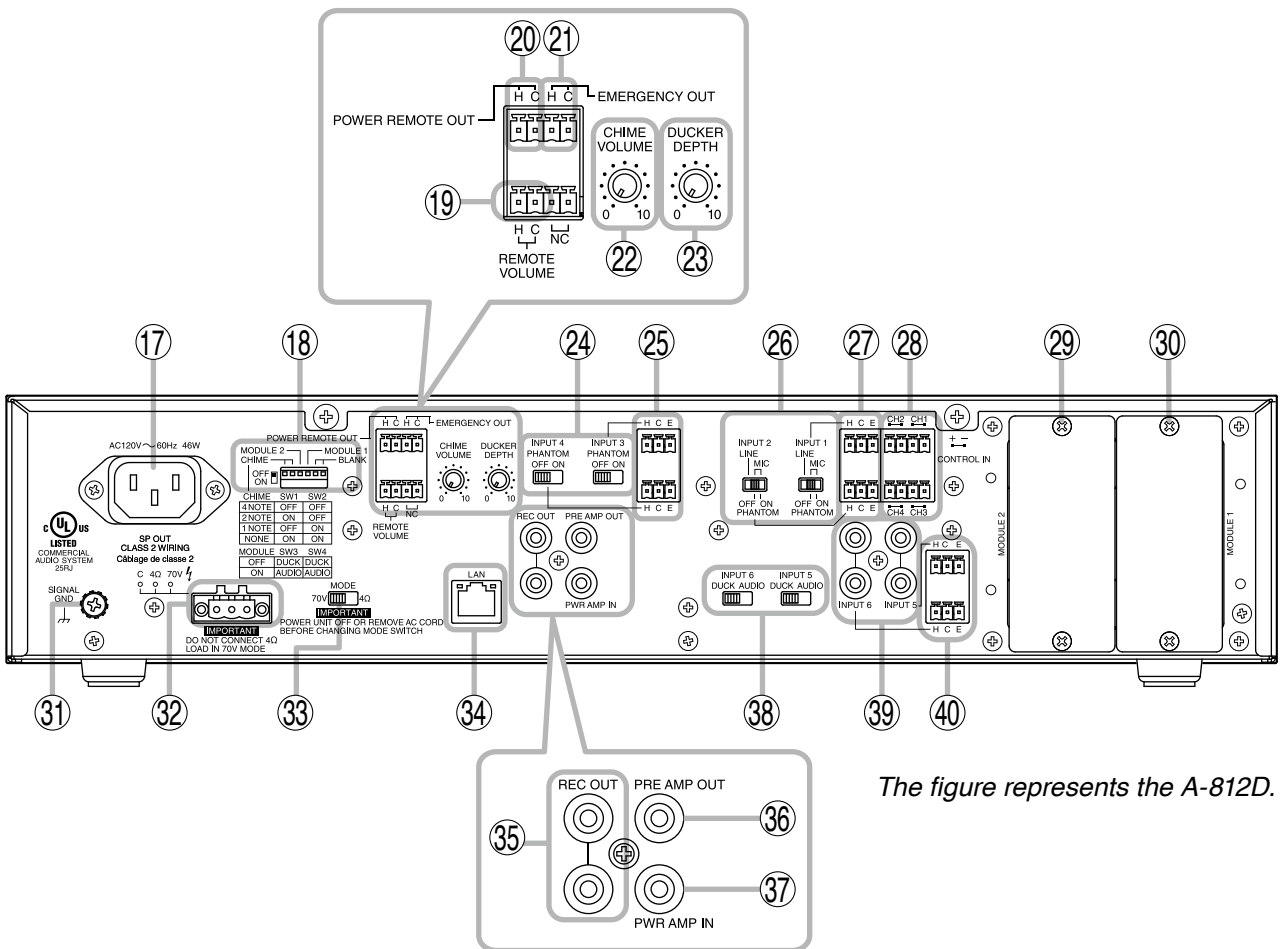

The figure represents the A-812D.

17. AC inlet

Connect the supplied power cord to this receptacle.

⚠ WARNING

Be sure to use the supplied power cord. Using any other power cord may cause electric shock.

18. DIP switch

- **Switches 1 and 2 (Chime tone setting switch)**
Set the chime tone to be used. (See "Chime Tone Setting" on p. 19.)
- **Switches 3 and 4 (Module setting switch)**
Set which to send the audio signals input from the Module slots 1 and 2 (30 and 29) to the AUDIO or DUCK using the DIP switch. (See "Module Setting" on p. 19.)
- **Switches 5 and 6**
Not used.

19. Remote master volume control terminal
 Short-circuit current: 10 mA or less,
 open voltage : 35 V DC or less,
 removable terminal block (3.50 mm, 4 pins)
 Sound volume can be adjusted by connecting the
 10 kΩ B-taper potentiometer.
 (See "Connecting to the Remote Master Volume
 Control Terminal" on p. 15.)

20. Power remote control output terminal
 Open collector output, withstand voltage: 30 V
 DC or less, current: 25 mA or less, removable
 terminal block (3.50 mm, 4 pins)
 An output terminal that can be used for remote
 control of other equipment. Operates in
 synchronization with the unit's power ON/OFF.
 When the unit's power is on, it is activated.

21. Emergency control output terminal
 Open collector output, withstand voltage: 30 V
 DC or less, current: 25 mA or less, removable
 terminal block (3.50 mm, 4 pins)
 An output terminal that can be used for remote
 control of other equipment.
 It is activated during the emergency broadcast
 made from the unit.

22. Chime volume control knob
 Adjusts the chime volume.
 Rotate the knob clockwise to increase the chime
 volume and counterclockwise to decrease it.

23. Ducker depth control knob
 Adjusts the automatically attenuated level of the
 sound volume on the DUCK while the broadcast
 is being made using the AUDIO.
 Rotate the knob clockwise to increase the
 attenuation on the DUCK and counterclockwise
 to decrease it.
 (See "DUCKER DEPTH ADJUSTMENT" on p. 20.)

24. Input setting switches (Inputs 3 and 4)
 Set whether or not to supply phantom power to
 the microphones connected to Inputs 3 and 4 (25).

Tip
 Phantom power is a 24 V DC.

25. Input terminals (Inputs 3 and 4)
 -60 dB*, 600 Ω, electronically-balanced,
 removable terminal block (3.81 mm, 3 pins)
 Input terminals dedicated for microphones

26. Input setting switches (Inputs 1 and 2)
 Set the input sensitivity level (LINE or MIC) of
 the Inputs 1 and 2 (27). When switched to the
 microphone input, set the phantom power to ON
 or OFF.

Switch position		Input specification at the time of setting
MIC	PHANTOM ON	-60 dB*, 600 Ω, phantom power ON
	PHANTOM OFF	-60 dB*, 600 Ω, phantom power OFF
LINE		-20 dB*, 600 Ω, with no phantom power

Tip
 Phantom power is a 24 V DC.

27. Input terminals (Inputs 1 and 2)
 -20 dB* (LINE)/-60 dB* (MIC), 600 Ω,
 electronically-balanced, removable terminal block
 (3.81 mm, 3 pins)
 Input sensitivity can be switched either to the
 Line input sensitivity or the Microphone input
 sensitivity.
 The input sensitivity can be changed with the
 Input setting switch (26).

**28. Control input terminals
 (Control inputs 1 through 4)**
 Short-circuit current: 10 mA or less,
 open voltage: 35 V DC or less,
 Removable terminal block (3.81 mm, 4 pins)
 Input the contact signals for controlling the priority
 broadcast.

29. Module slot 2
 Insert the optional module dedicated to the 900
 Series amplifier.

30. Module slot 1
 Insert the optional module dedicated to the 900
 Series amplifier.

31. Functional ground terminal
 Noise may be generated when external equipment
 is connected to the unit. In this case, connect
 this terminal to the functional ground terminal of
 the external equipment, and the noise may be
 reduced.

Note
 This ground is not for protective ground.

* 0 dB = 1 V

32. Speaker output terminal

Removable terminal block (5.00 mm, 3 pins)
Outputs the audio signals of the MAIN output or power amplifier output.
(See "BLOCK DIAGRAM" on p. 26.)

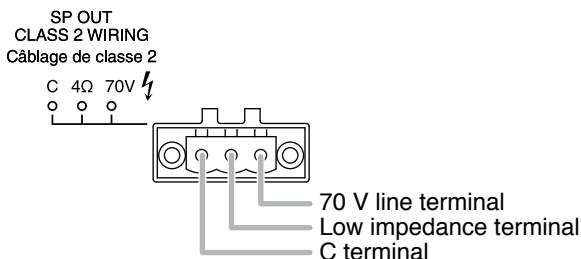

The table below shows the specifications of each output.

	A-812D	A-824D	A-848D
Rated output	120 W	240 W	480 W
Low impedance	4 to 16 Ω		
High impedance (70 V line)	42 Ω	21 Ω	10 Ω

Notes

- Never use the low impedance and high impedance terminals simultaneously. Doing so may cause damage to the unit or the peripheral equipment.
- Never make connection to 4 Ω terminal when the Impedance setting switch (33) is set to 70 V.

Tip

To change impedance between high and low, use the Impedance setting switch (33).

33. Impedance setting switch

Changes the speaker output impedance either to low or high.

70 V: High impedance
4 Ω: Low impedance

Notes

- Make sure that the power is switched OFF before changing this switch setting. Change cannot be performed when the power is on.
- The impedance remains as it is even if you change the switch setting when the power is ON. However, the impedance will change when you turn the power ON again after turning the power OFF.

34. Network terminal

RJ45 jack
Connect this terminal to the 100BASE-TX network using a STP Category 5 or greater straight through cable. A PC can be connected directly to this terminal without using a hub.

35. Recording output jacks

0 dB*, 600 Ω, unbalanced type, RCA jack x 2
Outputs the audio signals of the SUB output.
(See "BLOCK DIAGRAM" on p. 26.)
Used to record the broadcast contents by connecting the external recording device to these jacks.

36. Pre-amplifier output jack

0 dB*, 600 Ω, unbalanced type, RCA jack
Used to input the same audio signal as a speaker output of the unit into another power amplifier.

37. Power amplifier input jack

0 dB*, 600 Ω, unbalanced type, RCA jack
Input the output of the signal processor or other devices connected to the preamplifier output jack. (See "Connecting the External Equipment between the Pre-amplifier Output and the Power Amplifier" on p. 17.)
Connecting a pin plug to this jack disconnects the power amplifier section from the preamplifier section inside the unit.

38. Input setting switches (Inputs 5 and 6)

Set which to send the audio signals input from the Inputs 5 and 6 to the AUDIO or DUCK using the slide switches.
(See "BLOCK DIAGRAM" on p. 26.)

Output destination selection switch	Usable input terminal
AUDIO	AUDIO input terminal (Removable terminal block)
DUCK	DUCK input terminal (RCA jack)

39. DUCK input jacks (Inputs 5 and 6)

-20 dB*, 10 kΩ, unbalanced type, RCA jack x 2
To use these jacks, select "DUCK" with the Input setting switches (38).
(See "BLOCK DIAGRAM" on p. 26.)

40. AUDIO input terminals (Inputs 5 and 6)

-60 dB*, 600 Ω, electronically-balanced, removable terminal block (3.81 mm, 3 pins)
To use these terminals, select "AUDIO" with the Input setting switches (38).
(See "BLOCK DIAGRAM" on p. 26.)

* 0 dB = 1 V

9. CONNECTIONS

External cable wiring must be only carried out by qualified and trained personnel.

9.1. Speaker Connection

For cable wiring to the removable terminal block, refer to p. 18.

Notes

- Never make connection to both 4 Ω (low impedance) and 70 V line (high impedance) terminals simultaneously.
- Never make connection to 4 Ω terminal when the Impedance setting switch is set to 70 V.

Tip

Recommended speaker cable is IV or HIV cable with thickness described below.

Solid copper cable: $\varnothing 0.32 - 2.0 \text{ mm}$

Stranded copper cable: $0.05 - 3.3 \text{ mm}^2 \text{ (AWG 30 - 12)}$

A-812D/824D/848D

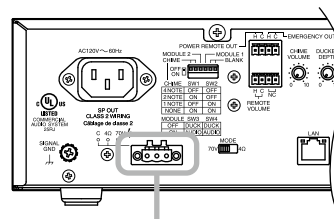

Speaker output terminal

[Low impedance connection]

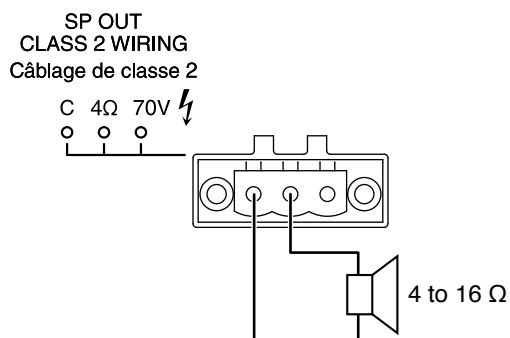

[High impedance connection]

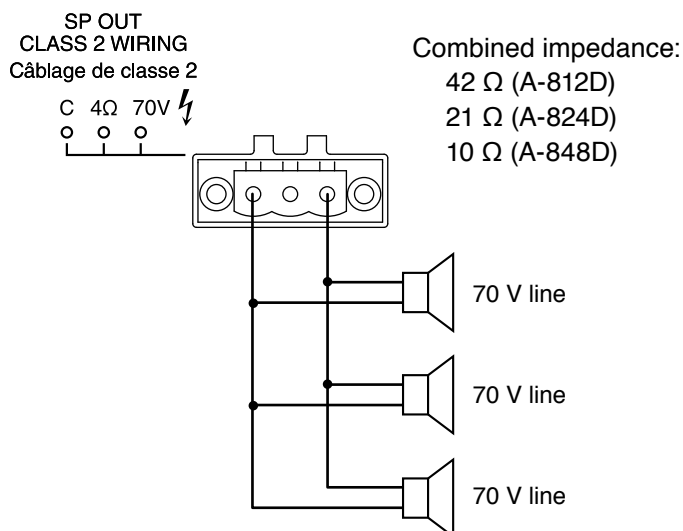

For the audio output at high impedance application setting, refer to "32. Speaker output terminal" on p. 11.

9.2. Input Terminal Connections and Settings

9.2.1. Connections

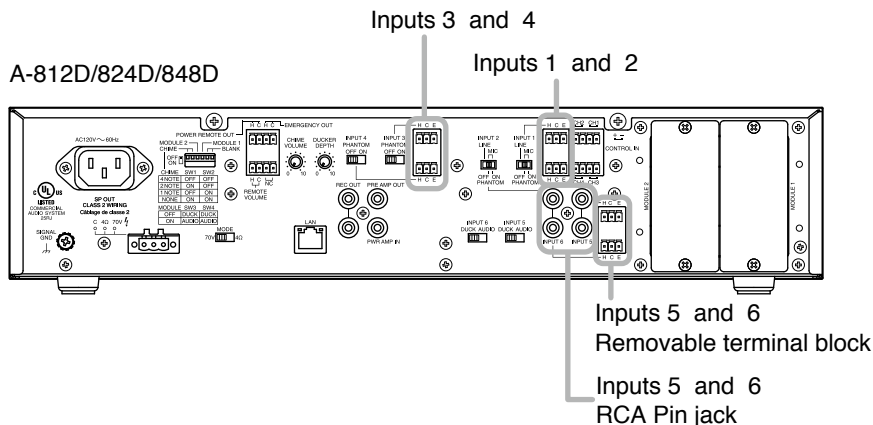

The terminal used for each of the Inputs 5 and 6 differs depending on the Input setting switches (input 5 and 6). (See the next page.)

Connect the cable to the correct terminal according to the input terminal to use.

[Inputs 1 through 6 (Inputs 5 and 6 connections are for routing to AUDIO)]

(When connecting a 2-core shielded cable)

(When connecting a single core shielded cable)

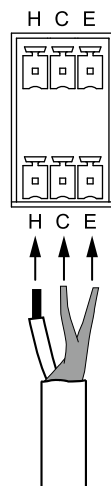
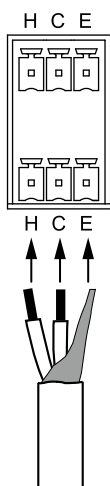

For cable wiring to the removable terminal plug, refer to p. 18.

[Inputs 5 and 6 (for routing to DUCK)]

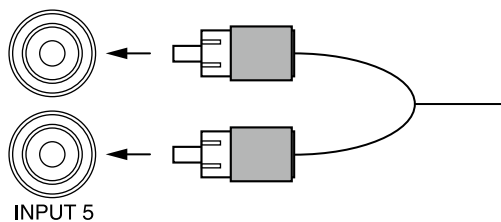

9.2.2. Inputs 1 through 6 settings

Each of Inputs 1 through 6 has its own setting switch corresponding to each input. Perform their settings as shown below as needed.

[Inputs 1 and 2]

Set the sound source level to connect and whether or not to use the phantom power when the microphone input is selected.

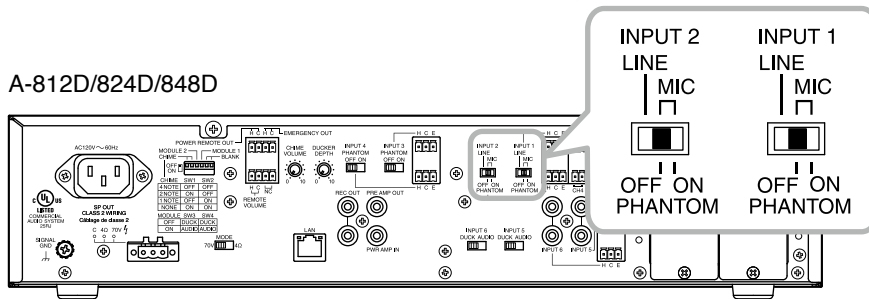

Input sound source	Switch position	Input specification
Line level	LINE	-20 dB*, 600 Ω
Microphone level, phantom power not required	MIC – PHANTOM OFF (Factory-preset)	-60 dB*, 600 Ω
Microphone level, phantom power required	MIC – PHANTOM ON	-60 dB*, 600 Ω

[Inputs 3 and 4]

Set whether or not to use phantom power on the Inputs 3 and 4 (dedicated microphone inputs).

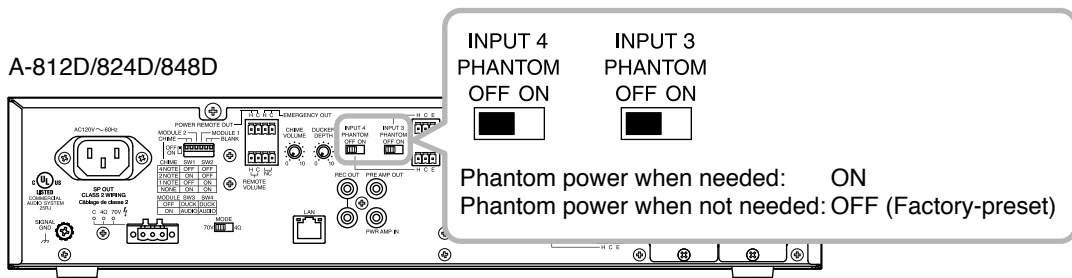

Input specifications: -60 dB*, 600 Ω, electronically balanced

[Inputs 5 and 6]

Set which to send the input audio signals to AUDIO or DUCK. Operation when the Ducker function works is different between AUDIO and DUCK. (See "DUCKER DEPTH ADJUSTMENT" on p. 20.)

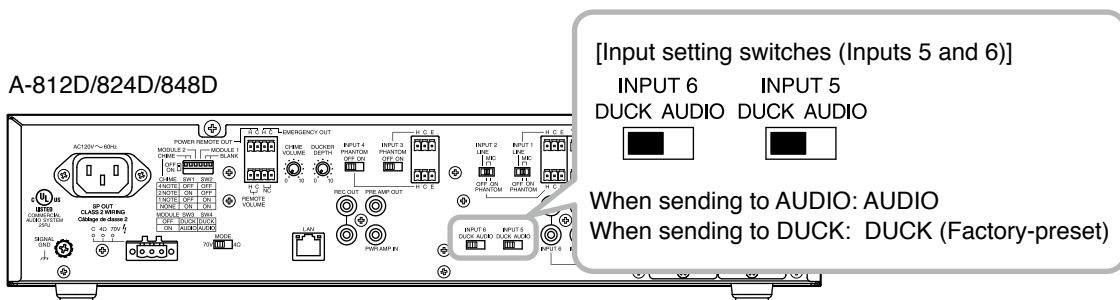

Input specifications: -60 dB*, 600 Ω, electronically balanced (when outputting to AUDIO)
 -20 dB*, 10 kΩ, unbalanced (when outputting to DUCK)

* 0 dB = 1 V

9.3. Connecting to the Remote Master Volume Control Terminal

You can remotely control the unit's volume level by connecting a volume controller. To remotely control the volume level, adjust the unit's volume level with the master volume control knob in advance. The level adjusted with the master volume control knob is the maximum volume level that you can remotely control.

For cable wiring to the removable terminal plug, refer to p. 18.

Note

Never set the master volume control knob to the minimum position. If set to the minimum, no sound is output even if you maximize the volume level through this terminal. (See "VOLUME ADJUSTMENT" on p. 20.)

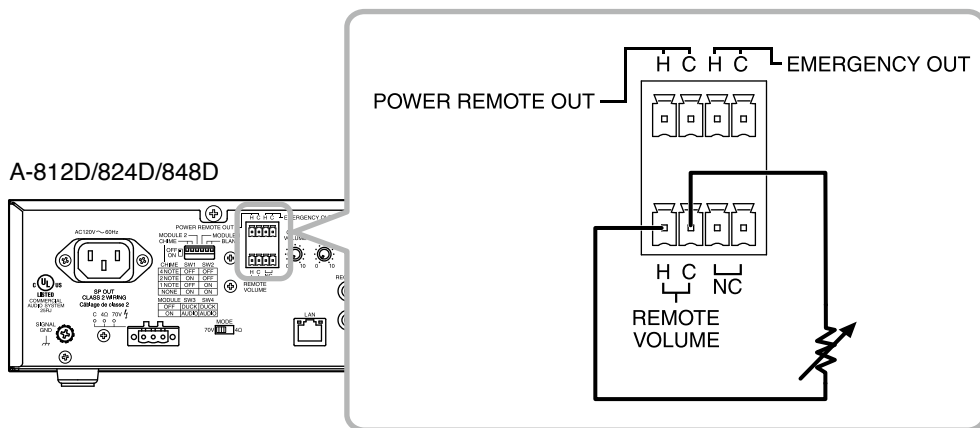

Connectable volume controller: 10 kΩ B-taper potentiometer

9.4. Connecting to the Power Remote Control Output Terminal

Use this terminal when remotely controlling other equipment. This terminal is activated when the unit is turned ON.

For cable wiring to the removable terminal plug, refer to p. 18.

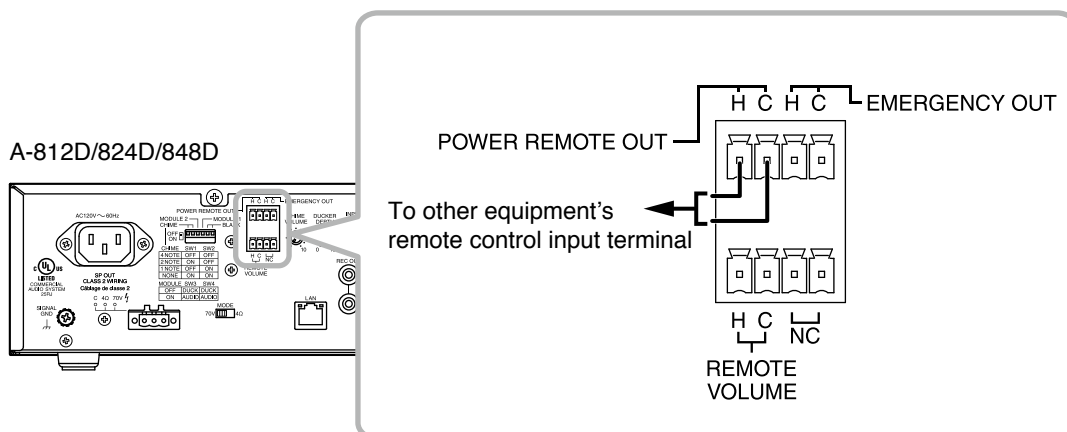

Output specifications: Open collector output, withstand voltage: 30 V DC or less, current: 25 mA or less

9.5. Connecting to the Emergency Control Output Terminal

Use this terminal when remotely controlling other equipment. This terminal is activated while the emergency broadcast is in progress from this unit.
 For cable wiring to the removable terminal plug, refer to p. 18.

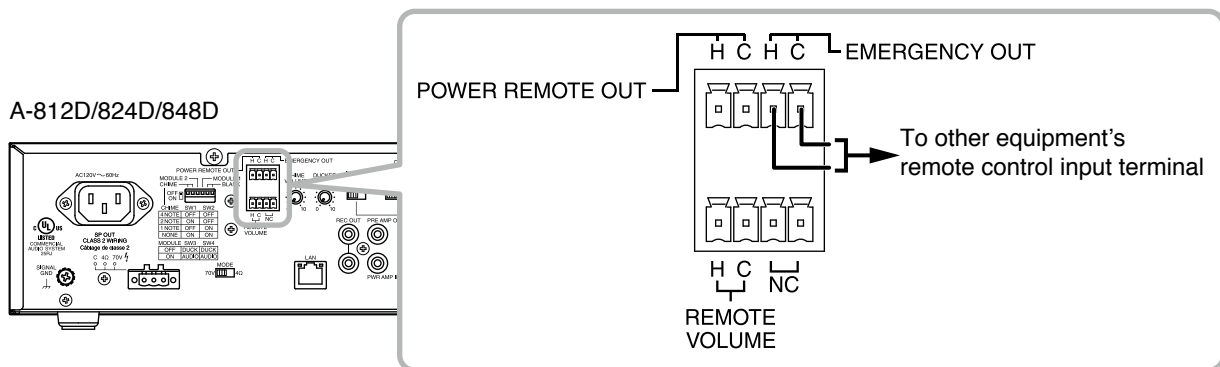

Output specifications: Open collector output, withstand voltage: 30 V DC or less, current: 25 mA or less

9.6. Connecting to the Control Input Terminal

Priority broadcast can be controlled by inputting the contact signal to these terminals.
 For the priority setting, refer to the separate setup manual, which can be downloaded from the TOA DATA Library (<https://www.toa-products.com/international/>).

For cable wiring to the removable terminal plug, refer to p. 18.

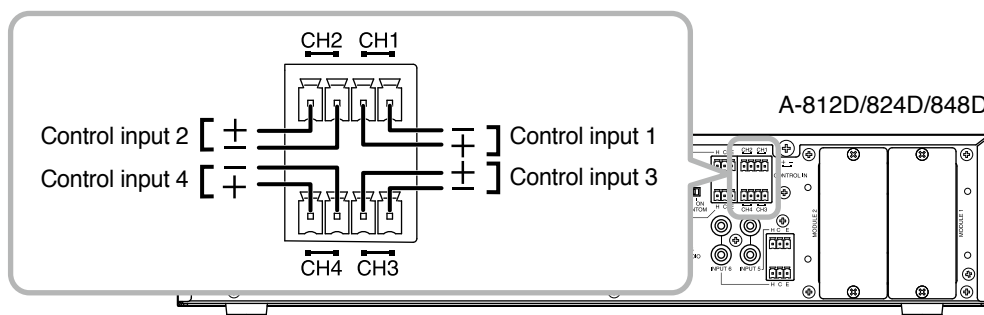

Input signal specifications: Short-circuit current: 10 mA or less, open voltage: 35 V DC or less

9.8. Removable Terminal Plug Connection

Step 1. Wiring the supplied removable terminal plug.

- 1-1. Loosen the terminal screws to insert the wire.
- 1-2. Tighten the terminal screws.
Ensure that the wire does not break free when pulled. If the wire does pull free, repeat the connection procedure from the start.

Step 2. Insert the wired terminal plug into the corresponding terminal block in the unit's rear panel.

Step 3. Only when the fixing screw is inserted, tighten the fixing screw.

Notes

- Do not reverse **Steps 1 and 2** above. Poor contact may result if force is applied to the unit's internal circuit board pins while the terminal screws are being tightened.
- When detaching the terminal plug, pull it straight out. Pulling it out at an angle may cause the terminal plug or terminal block to break.

Tips

- Applicable cable size

	For speaker output terminal	For other terminals
Conductor cross-section area	0.05 – 3.3 mm ²	0.08 – 2.0 mm ²
AWG	AWG 30 – 12 or equivalent	AWG 28 – 14 or equivalent

- Cable sheath to trim

Solid cable and stranded cable

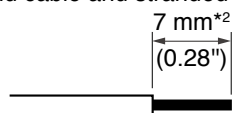

*2 Expose 8 mm (0.31") or more when using the above ferrule terminal, and cut off an extra conductor protruding from the sleeve.

Shielded cable

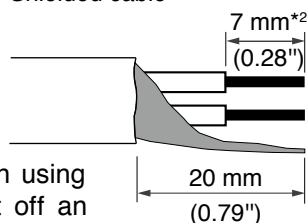

Note

Avoid soldering stranded or shielded cable, as contact resistance may increase when the cable is tightened and the solder is crushed, possibly resulting in an excessive rise in joint temperatures.

- When connecting 2 cables or a shielded cable to a single terminal, use a ferrule terminal with an insulation sleeve to crimp the cables because such cable conductors could become loose.

(1) Recommended ferrule terminals for signal cables

(made by Phoenix Contact)

Unit: mm (in)

	Model Number	a	b	l ₁	l ₂
①	AI 0,34-8 TQ	2 (0.08)	0.8 (0.03)	12.5 (0.49)	8 (0.31)
②	AI 0,5-8 WH	2.5 (0.1)	1.1 (0.04)	14 (0.55)	8 (0.31)

(2) Recommended ferrule terminals for speaker cables

(made by Phoenix Contact)

Unit: mm (in)

	Model Number	a	a ₁	a ₂	b	l ₁	l ₂
③	AI 1,5-8 BK	3.4 (0.31)	—	—	1.8 (0.07)	14 (0.55)	8 (0.31)
④	AI-TWIN 2 x 1,5-8 BK	—	6.6 (0.26)	3.6 (0.14)	2.3 (0.09)	16 (0.63)	8 (0.31)

Crimping tool: CRIMPFOX 10S (made by Phoenix Contact)

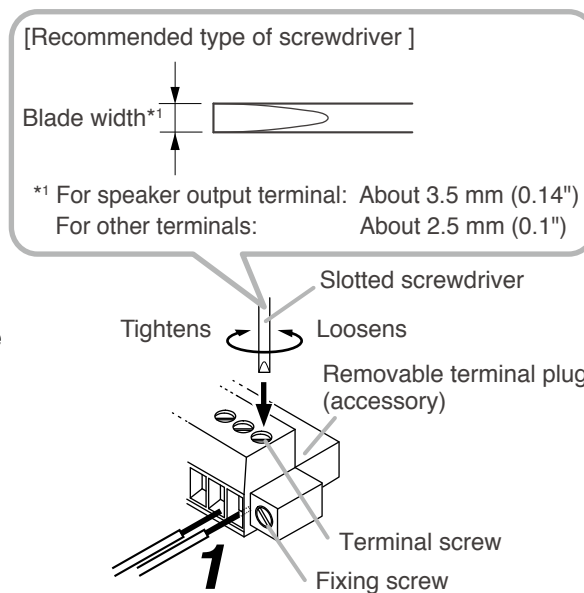

10. SETTINGS

10.1. Chime Tone Setting

Set the chime tone to use with the DIP switches 1 and 2.

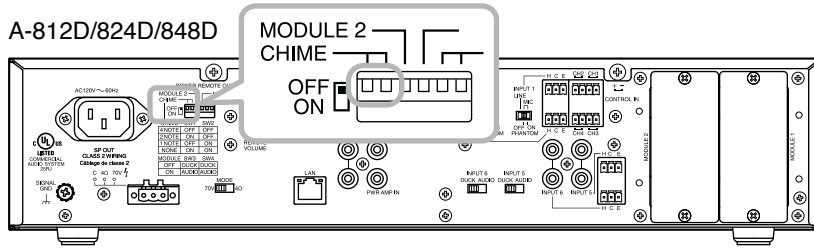

Chime tone to use	Switch 1	Switch 2	Switch's figures
4-note (Factory-preset)	OFF	OFF	OFF ON
2-note	ON	OFF	OFF ON
1-note	OFF	ON	OFF ON
Not used	ON	ON	OFF ON

10.2. Module Setting

Set which to send the output from the module input to the AUDIO or DUCK using Switches 3 and 4 of the DIP switch. (See "BLOCK DIAGRAM" on p. 26.)

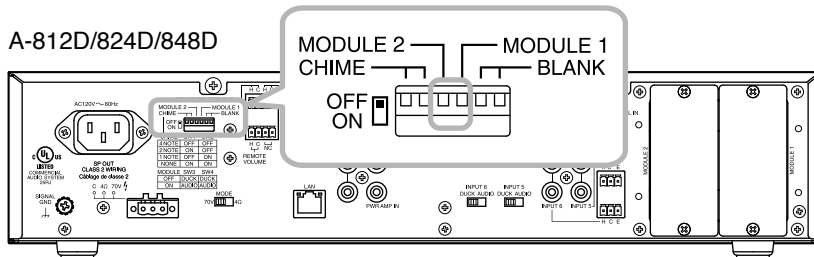

OFF: Output from the module input is sent to the DUCK.
 ON: Output from the module input is sent to the AUDIO.

11. DUCKER DEPTH ADJUSTMENT

The unit is equipped with Ducker function. When broadcast is made through AUDIO, the volume level of the audio signals input to DUCK is automatically attenuated.

Each input is sent to either AUDIO or DUCK as shown below.

Input No.	Input destination
Inputs 1 through 4	AUDIO
Inputs 5 and 6	AUDIO or DUCK selectable
Modules 1 and 2	AUDIO or DUCK selectable

Attenuation amount can be adjusted with the Ducker depth control knob. Rotate the knob clockwise to increase the attenuation amount and counterclockwise to decrease it.

When signals stop entering AUDIO, the volume level on DUCK automatically returns to its original level. (See "BLOCK DIAGRAM" on p. 26.)

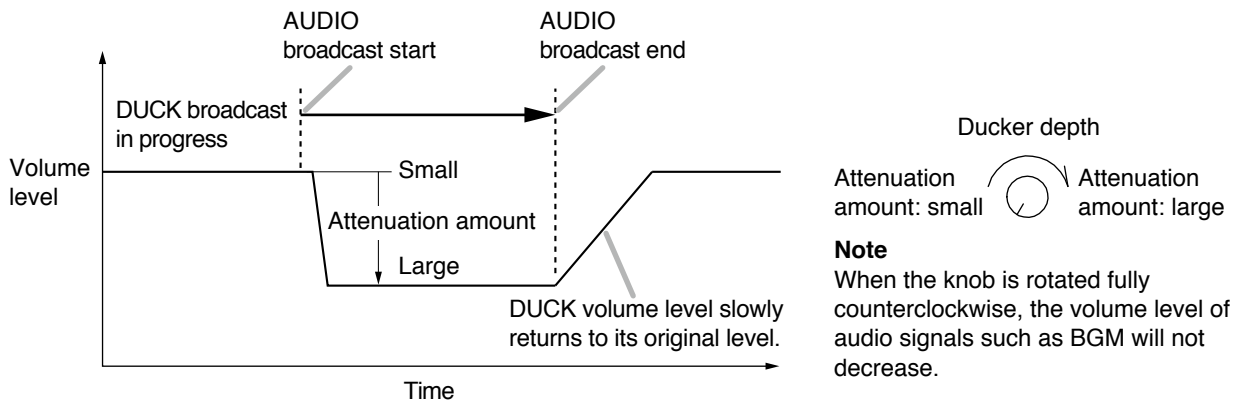

12. VOLUME ADJUSTMENT

The unit's volume value can be adjusted in 4 steps with the different means as described below.

- Inputs 1 to 6/Module inputs 1 and 2 volume control knobs
- Software master volume control
- Remote master volume control
- Master volume control knob

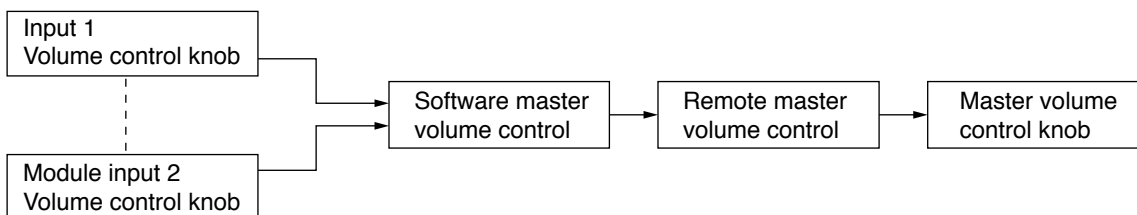

If any one of the volume controls is set to the minimum, no sound is output even if other volume control is set to the maximum. If you intend to adjust the volume value with the Software master volume control*¹ or the Remote master volume control (see p. 15), adjust the volume value using the master volume control knob in advance. The value adjusted with the master volume control knob is the adjustable upper limit.

When set to the Emergency broadcast, the broadcast is made at the maximum level regardless of the set values of the master volume, software master volume, and remote master volume*². Also, the chime is sounded at the maximum volume, and the characteristics of the EQ, tone control, and bass control are made flat.

The front-mounted emergency broadcast indicator lights during emergency broadcast, making the Emergency control output terminal closed.

*¹ Adjust the Software master volume control using the browser. For details, refer to the separate setup manual, which can be downloaded from the TOA DATA Library (<https://www.toa-products.com/international/>).

*² Volume control knobs for each input remain effective.

13. INSTALLING TO AN EQUIPMENT RACK

When installing the unit to an equipment rack, remove the four plastic feet screwed on the unit's base as shown below.

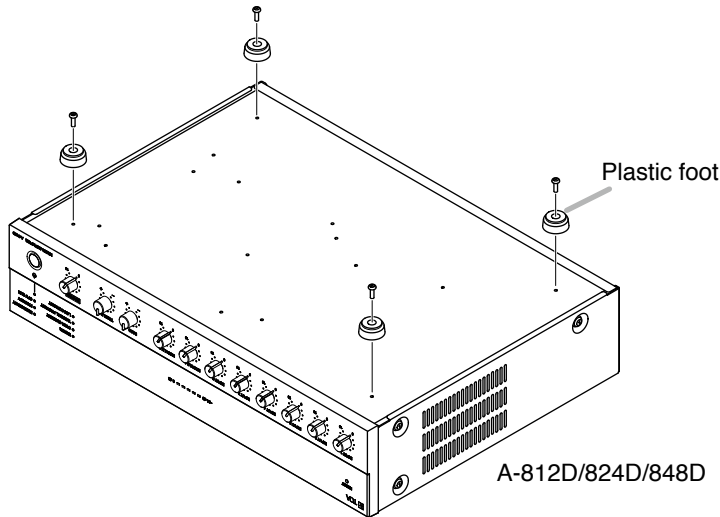

When installing the unit to an equipment rack, use the supplied rack mounting brackets.

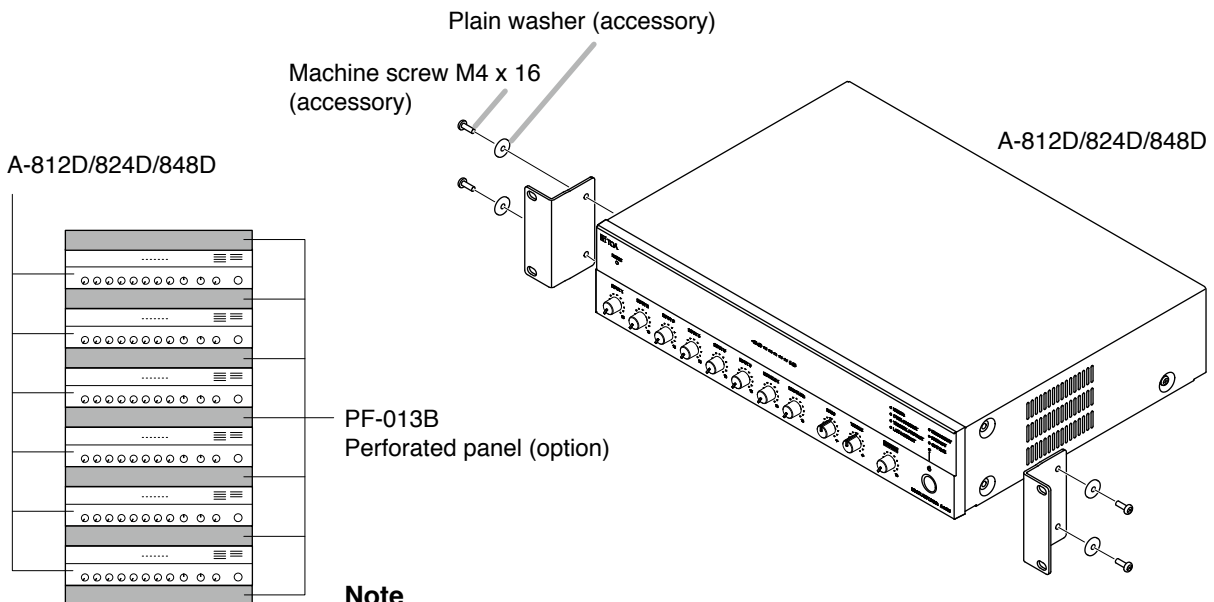

Note
To improve ventilation, ensure that a perforated panel (panel with air openings) of 1-unit size or greater is mounted over and under each unit, as well as on the top and at the bottom of the rack.

14. CONTROL SETTINGS

Output levels are adjustable with individual volume controls. For music play or announcements, adjust the corresponding volume control so that the red indicator doesn't light. Note that the sound quality is downgraded when the red indicator remains lit.

To prevent the accidental change of the settings of input volume and tone (Bass and Treble) controls, remove their knobs after setting them to the desired position and attach the supplied volume control covers instead.

A-3606D/3612D/3624D/3648D

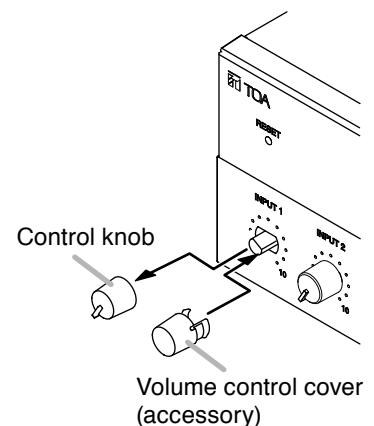

15. PRIORITY BROADCAST FUNCTION

Perform the settings related to the priority broadcast using a web browser. For details, refer to the separate setup manual, which can be downloaded from the TOA DATA Library (<https://www.toa-products.com/international/>).

15.1. Priority Broadcast

Priority broadcast function refers to a function that mutes the designated audio signal by means of the control signal or audio signal as a trigger when it is input.

One of 8 priority levels can be assigned to the signal that works as a trigger. When multiple triggers are input, the one with higher priority assigned takes precedence.

The Priority broadcast indicator on the front panel is lit while the priority broadcast is in progress.

Two modes are available for the priority broadcast: Standard mode and Manual mode. The unit will start in Standard mode when energized.

The mode can be changed using the web browser. For details, refer to the separate setup manual, which can be downloaded from the TOA DATA Library (<https://www.toa-products.com/international/>).

15.2. Priority Broadcast Mode

15.2.1. Standard mode

When making the priority broadcast in Standard mode, the following 8 signals can be used as triggers to activate the priority broadcast.

- Control inputs 1 through 4
- Audio detection (Inputs 1 and 2)
- Audio detection (Module inputs 1 and 2)

You can edit the following items related to the priority broadcast on the browser for each trigger. Designated audio signals can be muted in the case of normal broadcast that is not activated by any trigger. For details, refer to the separate setup manual, which can be downloaded from the TOA DATA Library (<https://www.toa-products.com/international/>).

Item	Setting contents
Valid/Invalid	When set to "Valid," priority broadcast will start if the corresponding trigger is input.
Priority level	<ul style="list-style-type: none">• You can set 8 different levels of priority. However, you cannot assign the same priority level to the multiple triggers. It means only 1 priority level can be assigned to a single trigger.• A trigger with the highest priority level assigned can be set to emergency broadcast. Note Emergency broadcast can be assigned only to the control input.• If a higher-priority trigger is input while a priority broadcast is in progress, the higher-priority broadcast takes precedence, overriding the current broadcast.• If a lower-priority trigger is input while a priority broadcast is in progress, the lower-priority trigger is ignored.
Chime ON/Chime OFF	Sounds the set chime when the trigger set to "Chime ON" is input. However, no chime sounds when the trigger is ignored. Note Chime can be assigned only to the control input.
Input to be muted/ Input not to be muted	Mutes the input set to "Input to be muted" when the priority broadcast is activated. Note It may take a few seconds before the volume level returns to the original level after mute is released.

Note

If the lower priority trigger that is so set to sound a chime is kept applied when the higher priority trigger stops, the chime will not sound even when the broadcast is switched to the lower priority one.

15.2.2. Manual mode

The designated audio signal can be muted from the browser in Manual mode. Use this mode to check the device operation. (See the separate setup manual*.) The unit's Network connection confirmation indicator lights in the manual mode.

* Can be downloaded from the TOA DATA Library (<https://www.toa-products.com/international/>).

15.3. Emergency Broadcast

You can set the priority broadcast with the highest priority level to the emergency broadcast. When set to the Emergency broadcast, the broadcast is made at the maximum level regardless of the set values of the master volume, software master volume, and remote master volume*. Also, the chime is sounded at the maximum volume, and the characteristics of the EQ, tone control, and bass control are made flat. The front-mounted emergency broadcast indicator lights during emergency broadcast, making the Emergency control output terminal closed.

* Volume control knobs for each input remain effective.

Note

Priority broadcast activated by way of the audio detection cannot be set to emergency broadcast.

15.4. Normal Broadcast

The broadcast that stays in the state where the unit's power is ON with no trigger input is referred to as the Normal broadcast.

Note

Chime at normal broadcast cannot be set to ON.

15.5. Relationship between the Priority/Emergency Broadcasts and the Power On/Off State

[When this unit is in power OFF state]

- This unit is turned ON when the Priority or Emergency broadcast by the control input starts.
- Even if you attempt to turn OFF the power* while the Priority or Emergency broadcast is in progress, this operation is invalid.
- This unit will be turned OFF when the Priority or Emergency broadcast terminates. However, if the higher priority broadcast by audio detection overlaps, the power will be turned OFF after this priority broadcast by audio detection is terminated.

[When this unit is in power ON state]

- This unit remains in power ON state regardless whether the Priority or Emergency broadcast starts or terminates.
- Even if you attempt to turn OFF the power* while the Priority or Emergency broadcast is in progress, this operation is invalid.

* Refers to the operation of pressing this unit's front-mounted power switch or clicking the Power ON checkbox to uncheck on the browser screen.

15.6. Factory Default Settings

[Factory default setting list]

Trigger	Priority level	Emergency	Chime	Audio inputs						Module		Status
				1	2	3	4	5	6	1	2	
Control input 1	High	Set	🔊	●	🔊	🔊	🔊	🔊	🔊	🔊	🔊	Valid
Control input 2		—	●	🔊	●	🔊	🔊	🔊	🔊	🔊	🔊	Valid
Control input 3		—	●	●	●	●	●	●	●	●	●	Valid
Control input 4		—	🔊	●	●	●	●	●	●	●	●	Valid
Audio detection (Input 1)	Low	—	🔊	●	🔊	🔊	🔊	🔊	🔊	🔊	🔊	Invalid
Audio detection (Input 2)		—	🔊	🔊	●	🔊	🔊	🔊	🔊	🔊	🔊	Invalid
Audio detection (Module 1)		—	🔊	🔊	🔊	🔊	🔊	🔊	🔊	●	🔊	Invalid
Audio detection (Module 2)		—	🔊	🔊	🔊	🔊	🔊	🔊	🔊	🔊	●	Invalid
Normal broadcast	—	—	🔊	●	●	●	●	●	●	●	●	—

Notes

- Inputs marked "🔊" in the Chime field are set to "Chime OFF," while those marked "●" are set to "Chime ON."
- Inputs marked "🔊" in the Audio input field are set to "Muted," while those marked "●" are set to "Not muted."
- The unit starts up in Standard mode.

Shown below are the operations by the factory default.

[Operation image]

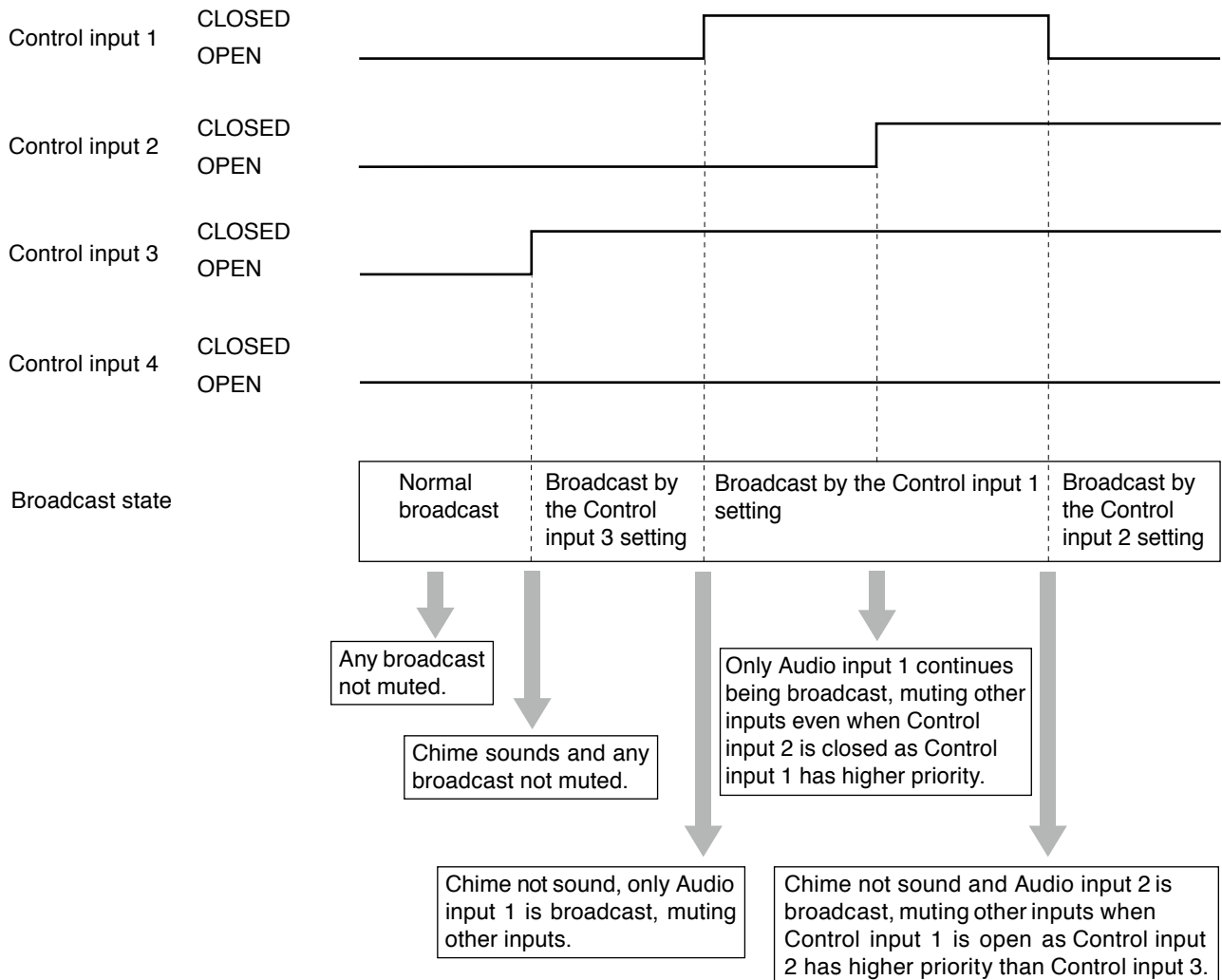

16. SETTINGS ON THE BROWSER

You can perform the settings and the displays shown below via the network by connecting a PC to the 800D Series mixer amplifier from the browser *¹.

- Status display*²
- EQ parameter control and display
- Setting content display
- Input priority setting and display
- Network setting
- Account setting
- Firmware update

*¹ The browsers that have been verified to work are Microsoft Edge, Google Chrome, and Mozilla Firefox.

Notes

- Microsoft Edge is the registered trademark of Microsoft Corporation in the United States and other countries.
- Google Chrome is the trademark of Google LLC in the United States and other countries.
- Mozilla and Firefox are the trademarks of The Mozilla Foundation in the United States and other countries.

*² If the volume value is set to the minimum on this screen, no sound is output even if you set the unit's front-mounted volume control knobs to the maximum position. Also, the volume value set on this screen becomes the maximum setting value, disabling the unit's front-mounted volume control knobs to increase the volume value exceeding this value.

For the details of the browser settings, refer to the separate setup manual, which can be downloaded from the TOA DATA Library (<https://www.toa-products.com/international/>).

17. BLOCK DIAGRAM

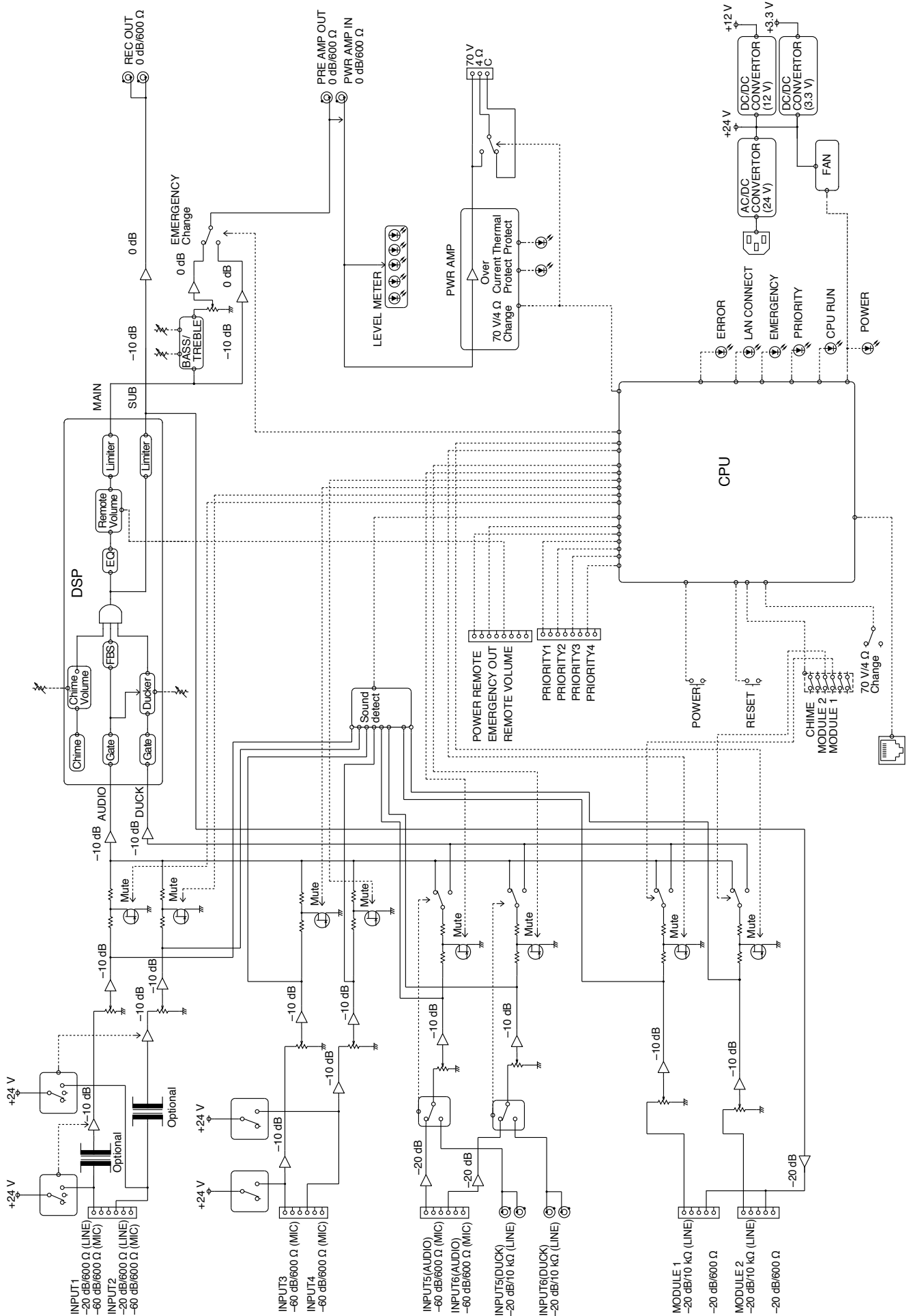

18. SPECIFICATIONS

MODEL	A-812D	A-824D	A-848D
Power Source	120 V AC, 60 Hz		
Rated Output	120 W	240 W	480 W
Power/Current Consumption	170 W (rated output), 46 W (based on UL62368), 200 mA or less (when power switch is OFF)	317 W (rated output), 62 W (based on UL62368), 200 mA or less (when power switch is OFF)	621 W (rated output), 103 W (based on UL62368), 200 mA or less (when power switch is OFF)
Frequency Response	50 Hz to 20 kHz \pm 3 dB (1/8 rated output)		
Distortion	1% or less at 1 kHz, rated power (20 kHz LPF (AUX-0025))		
Tone Control	Bass: \pm 10 dB at 100 Hz, Treble: \pm 10 dB at 10 kHz		
Signal to Noise Ratio	88 dB or more (Master volume: min) 76 dB or more (Master volume: max) 55 dB or more (INPUT 1 to 6) (A-weighted)		
Audio Input			
INPUT 1, 2	-60 dB* (MIC)/-20 dB* (LINE) selectable, 600 Ω , electronically-balanced, removable terminal block (3.81 mm, 3 pins) Note MIC inputs are equipped with phantom power (24 V DC, ON/OFF switchable).		
INPUT 3, 4	-60 dB*, 600 Ω , electronically-balanced, removable terminal block (3.81 mm, 3 pins) Note Equipped with phantom power (24 V DC, ON/OFF switchable).		
INPUT 5, 6	MIC/LINE selectable MIC: -60 dB*, 600 Ω , electronically-balanced, removable terminal block (3.81 mm, 3 pins) LINE: -20 dB*, 10 k Ω , unbalanced, RCA pin jack x 2		
MODULE 1,2	-20 dB*, 10 k Ω		
PWR AMP IN	0 dB*, 600 Ω , unbalanced, RCA pin jack (An equalizer or other signal processor connectable between PRE AMP OUT and PWR AMP IN terminals.)		
Input Bus			
Input 1 to 4	AUDIO		
Input 5, 6	AUDIO/DUCK selectable		
Module 1, 2	AUDIO/DUCK selectable		
Audio Output			
SPEAKER OUT	High impedance : (70 V line/42 Ω)/ Low impedance : (4 to 16 Ω) selectable	High impedance (70 V line/21 Ω)/ Low impedance (4 to 16 Ω) selectable	High impedance (70 V line/10 Ω)/ Low impedance (4 to 16 Ω) selectable
	removable terminal block (5.00 mm, 3 pins)		
REC OUT	0 dB *, 600 Ω , unbalanced, RCA pin jack x 2		
PRE AMP OUT	0 dB *, 600 Ω , unbalanced, RCA pin jack		
Control Input	4 channels, no-voltage make contact input, open voltage: 35 V DC or less, short-circuit current: 10 mA or less, removable terminal block (3.81 mm, 4 pins) REMOTE VOLUME: Removable terminal block (3.50 mm, 4 pins)		
Control Output	POWER REMOTE: Open collector output, withstand voltage: 30 V DC or less, control current: 25 mA or less, removable terminal block (3.50 mm, 4 pins) EMERGENCY OUT: Open collector output, withstand voltage: 30 V DC or less, control current: 25 mA or less, removable terminal block (3.50 mm, 4 pins)		
Chime	1-note, 2-note, or ascending 4-note chime or None selectable with switch setting		
Indicators	LED level meter, Power indicator, Network connection confirmation indicator, Priority broadcast indicator, Emergency broadcast indicator, Thermal protection indicator, Overcurrent protection indicator, CPU running indicator, Error indicator		
Operating Temperature	-10 to +40 $^{\circ}$ C (14 to 104 $^{\circ}$ F)		
Operating Humidity	85%RH or less (no condensation)		
Finish	Panel: ABS resin, black Case: Surface-treated steel plate, black, paint		
Dimensions	420 (w) x 96.1 (h) x 313.1 (d) mm or 16.54" x 3.78" x 12.33"		
Weight	5.2 kg or 11.46 lb		5.4 kg or 11.9 lb

* 0 dB = 1 V

Note: The design and specifications are subject to change without notice for improvement.

• **Accessories**

Power cord (2 m or 6.56 ft)	1	Volume control cover	4
Audio input removable terminal plug (3.81 mm,3 pins)	6	Rack mounting bracket	2
Control input removable terminal plug (3.81 mm,4 pins)	2	Machine screw M4 x 16	4
Remote control removable terminal plug (3.50 mm, 4 pins)	2	Plain washer	4
Speaker out removable terminal plug (5.00 mm, 3 pins)	1		

• **Optional product**

Input transformer: IT-450
Perforated panel: PF-013B

FCC REQUIREMENTS

Note

This equipment has been tested and found to comply with the limits for a Class A digital device, pursuant to Part 15 of the FCC Rules. These limits are designed to provide reasonable protection against harmful interference when the equipment is operated in a commercial environment. This equipment generates, uses, and can radiate radio frequency energy and, if not installed and used in accordance with the instruction manual, may cause harmful interference to radio communications.

Operation of this equipment in a residential area is likely to cause harmful interference in which case the user will be required to correct the interference at his own expense.

Modifications

Any modifications made to this device that are not approved by TOA Corporation may void the authority granted to the user by the FCC to operate this equipment.

This Class A digital apparatus complies with Canadian ICES-003.
Cet appareil numérique de la classe A est conforme à la norme NMB-003 du Canada.

DECLARATION

Any modification to the unit, unless expressly approved by TOA Electronics, Inc., could void your authority to operate the equipment.

DECLARATION OF CONFORMITY

TOA Electronics, Inc.
1 Harmon Plaza, Suite 602 Secaucus, New Jersey 07094, USA
TEL 650-452-1200

declare under our sole responsibility that the product
800D SERIES MIXER AMPLIFIER
A-812D 3CU, A-824D 3CU, A-848D 3CU

comply with Part 15 of FCC Rules.

Operation is subject to the following conditions: (1) this device may not cause harmful interference, and (2) this device must accept any interference received, including interference that may cause undesired operation.

Traceability Information for USA

Manufacturer:
TOA Corporation
7-2-1, Minatojima-Nakamachi, Chuo-ku, Kobe, Hyogo,
Japan

Authorized representative:
TOA Electronics, Inc.
1 Harmon Plaza, Suite 602 Secaucus,
New Jersey 07094,
USA

URL: <https://www.toa.jp/>