

MIPRO®

Rechargeable Wireless Microphone

ACT-52HC UHF

ACT-32HC UHF

ACT-24HC 2.4 GHz

User Guide

ACT-52HC



ACT-32HC



ACT-24HC

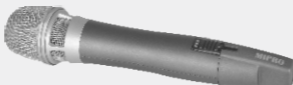

I. Parts Name, Fig. 1

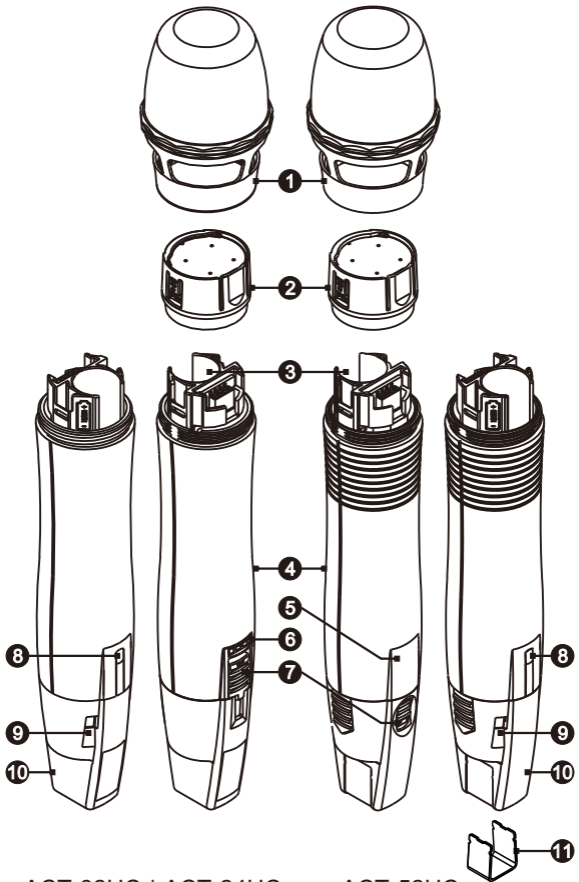

ACT-32HC | ACT-24HC

ACT-52HC

Fig. 1

- ① Microphone Capsule Module.
- ② Fixed Ring.
- ③ Battery Compartment.
- ④ Housing.
- ⑤ LCD Screen.
- ⑥ Battery Meter Indicators.
- ⑦ Power Switch.
- ⑧ ACT Sync Window.
- ⑨ Battery Charging Contacts.
- ⑩ Protection Cover.
- ⑪ Channel ID Clip. (Additional)

II. LCD Display, Fig. 2



Fig. 2

- ⑫ Transmitter Functions.
- ⑬ Transmitter Parameters.
- ⑭ Transmitter Battery Display.

III. Battery Installation, Fig. 3

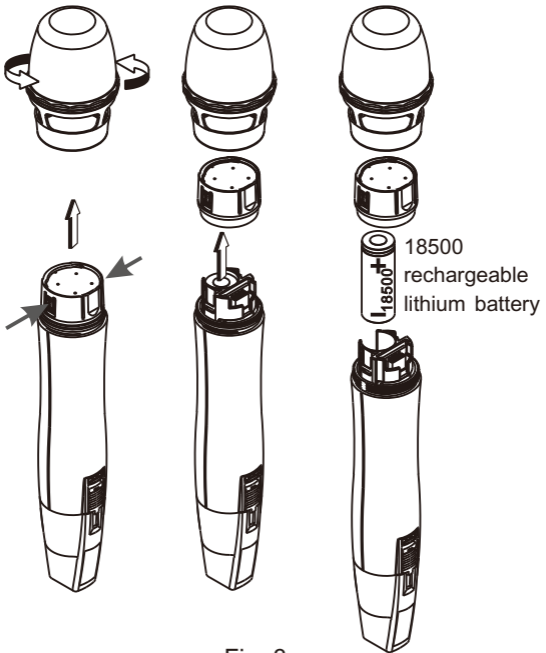

Fig. 3

1. Rotate and remove microphone capsule module ❶ counterclockwise.
2. Press both sides of Fixed Ring ❷ to pull out Fixed Ring. Insert or remove a 18500 rechargeable battery.

3. Insert a 18500 rechargeable battery with positive + facing up. Put the Fixed Ring back and ensure the hook is positioned and then rotate the capsule module tight.
4. Notice:
 - (A) If inserted with correct polarity and still cannot be powered on, it could be due to battery protection mechanism is activated. Insert the whole transmitter back to the charging station for 10 seconds to deactivate and power on again.
 - (B) If charging station is not used, reverse battery polarity for 10 seconds then re-inserted with correct polarity to wake up the battery. Power on again.

IV. Operating Instructions

ACT-32HC | ACT-24HC:

1. Power on: Push the Power Switch ⑦ to ON, the Battery Meter Indicators ⑥ are lit.
Power off: Push to OFF, the Battery Meter Indicators are dim.
2. Do ACT synchronization according to the operating instructions of receiver's ACT Set-up.
3. When microphone catches sound, the AUDIO signal indicators on the receiver panel will blink. It indicates the wireless transmission between microphone and receiver is normal.

ACT-52HC:

1. Remove protection rear cover to expose MODE and SET buttons, Fig. 4.

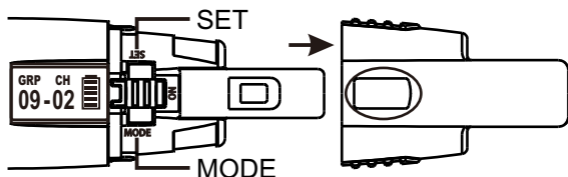

Fig. 4

2. Press MODE button to access one of the 5 parameters below and press SET button to activate parameters for changing, Fig. 5.

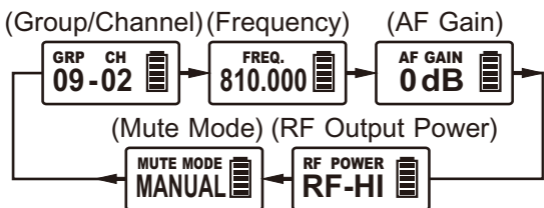

Fig. 5

3. Under GROUP / CHANNEL and FREQUENCY modes, it display message in accordance with receiver, Fig. 6.

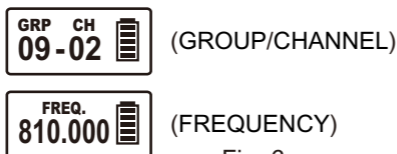

Fig. 6

4. AF GAIN: Audio Gain, Fig. 7

- (A) Adjusts audio level from 0dB to 6dB in 3dB step.
- (B) Press MODE button to access AF GAIN parameter. Press SET button, the parameter value flashes. Press SET button again and the values rotate by each press. Press MODE button to save the selected value or the value will save automatically when it stops flashing.
- (C) The higher the gains, the lower the dynamic range for signal input and the greater the danger of unwanted noises and higher chances of feedback.
- (D) The default value of AF Gain is 0dB.



Fig. 7

5. RF POWER: PF Power, Fig. 8

- (A) Two parameter values: RF-HI and RF-LOW.
- (B) Press MODE button to access RF POWER parameter. Press SET button, the parameter value flashes. Press SET button again and the values rotate by each press. Press MODE button to save the selected value or the value will save automatically when it stops flashing.



Fig. 8

6. MUTE MODE: audio mute, Fig. 9

- (A) Two parameters: MANUAL and DISABLE.
- (B) Press MODE button to access RF POWER parameter. Press SET button, the parameter value flashes. Press SET button again and the values rotate by each press. Press MODE button to save the selected value or the value will save automatically when it stops flashing.
- (C) MANUAL: MUTE is controllable by pressing the external MUTE button.
- (D) DISABLE: Mute is disabled and cannot be muted in any method.



Fig. 9

V. Battery Level Status

1. ACT-32HC | ACT-24HC:

When the battery is in low voltage and the red indicator is lit, it needs to be charged. If low voltage condition continues, it will power off automatically, Fig. 10.

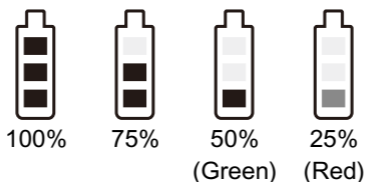

Fig. 10

2. ACT-52HC:

When the battery has less than 10% power remaining (0-bar displayed), it needs to be recharged. If under voltage condition continues, the screen will show “OFF...” and it will power off automatically, Fig. 11.

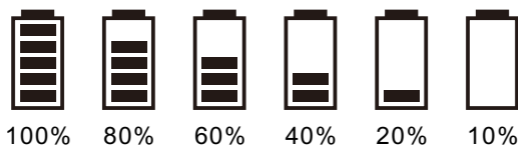

Fig. 11

VI. Power On/Off

ACT-52HC:

1. Slide up or down the Power Switch **7** to power on or off. LCD screen **5** is lit once it's powered.
2. "OFF..." appears during power off, Fig. 12.



Fig. 12

3. Error codes:
 - (A) ERR no01→Transmitter does not have the initial programmed data.
 - (B) ERR no02→(for test)RF circuitry failure, frequency cannot be programmed.
 - (C) ERR no03→The frequency to be set exceeds the upper limit of the microphone. It cannot be synced, thus, no RF and audio transmission. Power on the microphone again to reset.
 - (D) ERR no04→ The frequency to be set exceeds the lower limit of the transmitter. It cannot be synced, thus, no RF and audio transmission. Power on the microphone again to reset.

4. GROUP CHANNEL: The preset frequency of receiver.
5. Only "CHANNEL" displays: User-defined frequency of receiver and needs to be changed via PC.

VII. MUTE setting, Fig.13

ACT-52HC:

1. Press MUTE button to enter mute status.
2. Press MODE and SET buttons to change other parameters, but it will return to MUTE mode after 5 seconds.
3. Press MUTE button again to unmute.
4. "UNMUTE" only shows for 1 second and then go back to the main display.
5. MUTE button can work only under MANUAL mode.

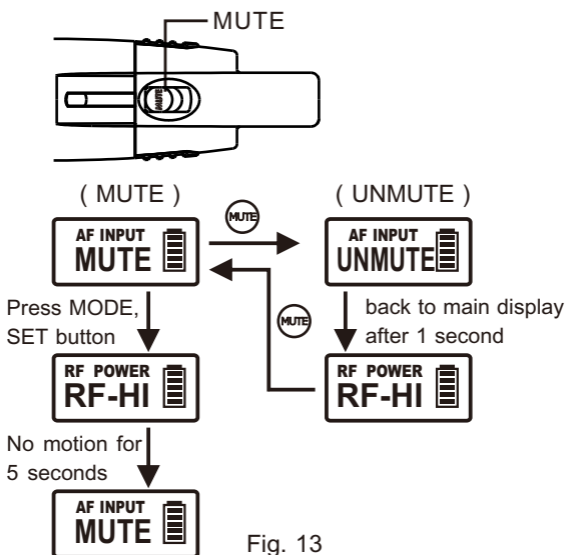

VIII. Protection rear cover to prevent accidental power on/off

1. To prevent users from powering off the microphone accidentally, take out and reverse the protective rear cover, Fig. 14 & 15.
2. We recommend the rear cover is installed during usage.

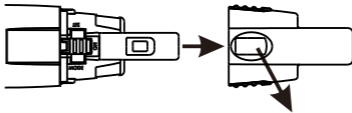

Fig. 14: Power switch is exposed

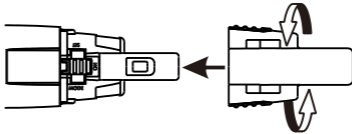

Fig. 15:

Power switch is covered after 180-degree reversal

IX. Caution

1. Turn off to save battery life when not in use. Remove the battery not use for an extended period of time.
2. To improve efficiency of transmitting antenna, do not cover the hands over the rear housing section.
3. To prevent degraded microphone sound quality, directionality and annoying feedback, do not cover the hands over microphone grill.
4. Correct posture of holding the handheld microphone is required because the distance between the microphone and the mouth will have a significant impact on the sensitivity and sound quality.
5. Keep the microphone grill clean and unblocked to enhance pick-up sound quality.

X. Transmitter Battery Chargers (optional)

1. Transmitter(s) can be recharged by docking into a MP-8 or MP-80 charger, Fig. 16 and 17. Or charge up to two 18500 batteries in MP-80, Fig. 18.
2. MP-8 Single-slot Docking Charger, Fig. 16.
3. MP-80 Dual-slot Docking Charger, Fig. 17.

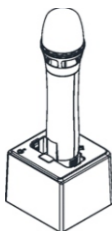

Fig. 16:
Handheld
transmitter
charging
in MP-8

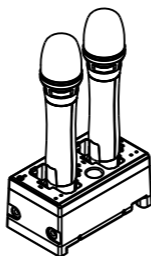

Fig. 17:
Handheld
transmitter
charging
in MP-80

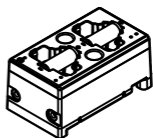

Fig. 18:
18500
rechargeable
battery charging
in MP-80

XI. Notes

1. Refer to actual product in the event of product description discrepancy.
2. Frequency range and maximum deviation comply with the regulations of different countries.

FCC

FCC Caution: To assure continued compliance, any changes or modifications not expressly approved by the party responsible for compliance could void the user's authority to operate this equipment. (Example - use only shielded interface cables when connecting to computer or peripheral devices).

This device complies with Part 15 of the FCC Rules. Operation is subject to the following two conditions:

- (1) This device may not cause harmful interference, and
- (2) This device must accept any interference received, including interference that may cause undesired operation.

This device complied with FCC radiation exposure limits as set forth for an uncontrolled environment. This device should be installed and operated so that its antenna(s) are not co-located or operating in conjunction with any other antenna or transmitter.

IC

This device complies with Industry Canada's RSSs. Operation is subject to the following two conditions:

- (1) This device may not cause interference; and
- (2) This device must accept any interference, including interference that may cause undesired operation of the device.

Le présent appareil est conforme aux CNR d'Industrie Canada applicables aux appareils radio. L'exploitation est autorisée aux deux conditions suivantes :

- (1) l'appareil ne doit pas produire de brouillage;
- (2) l'utilisateur de l'appareil doit accepter tout brouillage radioélectrique subi, même si le brouillage est susceptible d'en compromettre le fonctionnement.

MIPRO[®]
MICROPHONE PROFESSIONALS

MIPRO Electronics Co., Ltd

Headquarters : 814 Pei-Kang Road, Chiayi,60096,Taiwan

Tel : +886.5.238.0809

www.mipro.com.tw

Fax : +886.5.238.0803

mipro@mipro.com.tw

All rights reserved. MN 018/11

Do not copy or forward without prior approvals MIPRO.

Specifications and design subject to change without notice.



2 CE6 17 A