

TAS-2

Install Manual



Introduction

Thank you for purchasing the AtlasIED TAS-2 Temporary Audio System. This speaker/microphone system is designed to provide high intelligibility and coverage in applications including DJ/festivals, house of worship, public speaking, schools, temporary emergency staging areas, and other locations where fixed installation is not a requirement or is not possible including multi-purpose facilities.

This system has been configured for a fast installation that can be set up and functional in less than an hour.

Contents



- (12) SM42-T 4" 2-way speakers
- (12) T3664 stands
- (4) Carrying bags for up to (3) mic stands; all wires and cables needed



(1) AC Power Conditioner (AP-C15D)



(1) Mixer Amplifier for Multi-Source Master Control (AA100PHD) with Message Repeater



(1) M600-DT Desktop Microphone



(1) Portable rack

Speaker Placement

The first step in properly setting up the system is to determine the required area the speakers need to cover. The speakers can be placed in a straight line spaced up to 20' apart to cover a single field, see Figure 1.

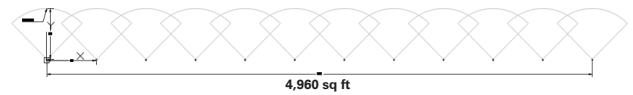

Figure 1

The speakers can also be placed back to back to cover an area in two directions. Figure 2

The system includes twelve (12) speakers. The speakers can be used all together in combination based on need and area to cover making the system extremely versatile.

Once the speaker placement has been determined the T3664 speaker stands can be positioned.

CAUTION: The speaker stands **MUST** be positioned on a firm flat surface and the pole must be perpendicular to the ground.

NOTE: In windy areas AtlasIED strongly recommends placing sandbags on the legs of the stand. (Supplied by others)

1. Loosen the leg clamp knob and slide the clamp down the pole to extend the legs to their maximum diameter, then re-tighten the knob.
2. Loosen the top pole clamp and raise the inner tube 2" then retighten the clamp.
3. Place the SM42T bracket on the inner pole of the stand, install the nut on top of the bracket and tighten the nut so that the bracket cannot move. Position the speaker in the bracket and install the screw knobs on both sides of the speaker, aim the speaker toward the area that it needs to cover and then tighten the knobs. Repeat this process for the all speakers needed to cover the area. Figure 3

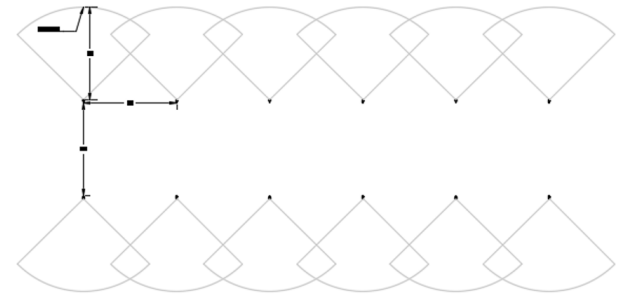

Figure 2

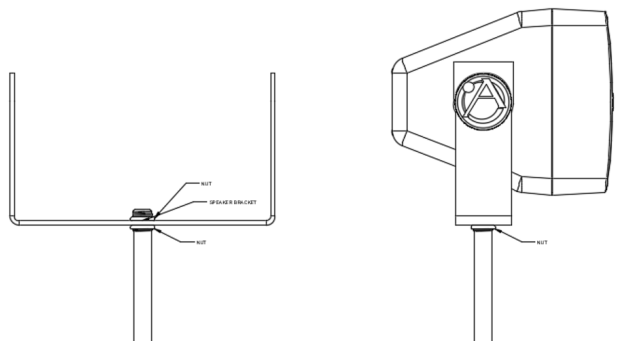

Figure 3

System Wiring

1. Setup the portable control rack at least 10' to one side of the first speaker, connect the microphone cable to the microphone and the "Mic In" connector on the back of the amplifier.
2. Unwind the included speaker wire located in the back of the control rack and route the end of the wire with bare copper ends to the closest speaker. Locate another spool of wire and connect them both to the first speaker as shown in Figure 4.

NOTE: It may be necessary to adjust the Power Selector, confirm it is set to the 5W 70.7V setting before replacing the back cover. Figure 5

3. Continue wiring one speaker to the next until they are all connected. Figure 6
4. Locate the 120V, 15-amp power cord in the rear of the control rack and connect it to a suitable 120VAC, 15-amp receptacle.

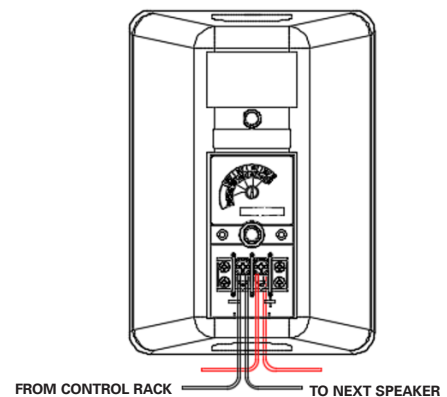

Figure 4

System Setup

Please refer to Figure 7 for product identification.

1. Ensure all the level controls on the AA100PHD amplifier are all turned to zero (counterclockwise).
2. Turn on the AP-C15D's power switch
3. Press the power button on the AA100PHD amplifier
4. Turn the "Master Level" control up to 5
5. Press the button on the M600-DT microphone and begin speaking into the microphone while slowly turning up the "1" control on the AA100PHD amplifier until the appropriate audio can be heard from the speakers.

It is best practice to push the mic switch to the Off position after announcements are made and to turn the power switch to the Off position on the AP-C15D if the system will not be used for an extended period of time.

This system includes a built-in message repeater that can be used to make announcements that will need to be repeated on a regular basis. The message repeater does not contain any messages from the factory so a message will need to be stored in the unit before it can be used. Figure 8

Please refer to the attached install sheet for the RDL FP-MR2 message repeater programming instructions. Once the unit is ready to record a message, make sure the AA100PHD amplifier is turned on and the level controls 1 and Master are set to a volume that can be heard from the speakers.

Start the recording session on the FP-MR2 while pressing the talk button on the microphone and speaking directly into the microphone to record the message. Once the message has been recorded, press the start button on the FP-MR2 and slowly turn the 2 level control up on the AA100PHD until the recorded audio can be heard from the speakers.

Refer to the attached FP-MR2 install sheet for instruction for playing the recorded message on a timer schedule.

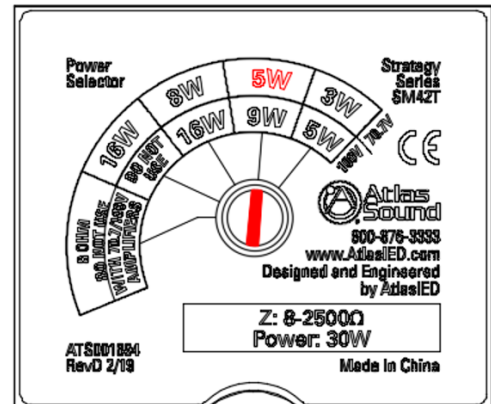

Figure 5

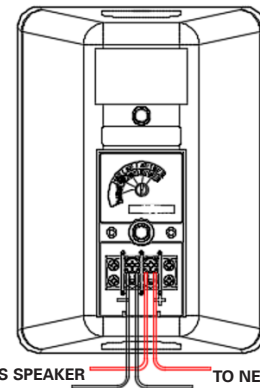

Figure 6

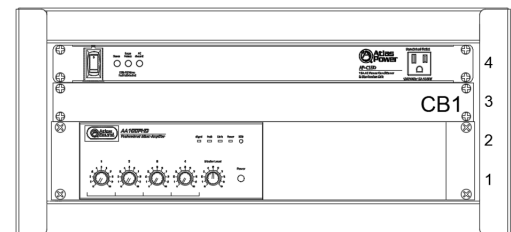

Figure 7

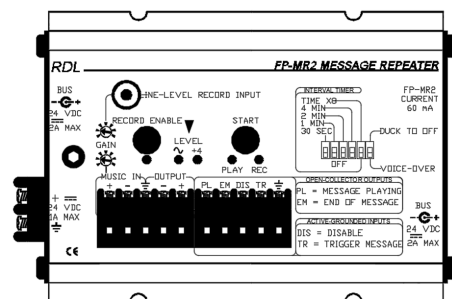

Figure 8



RDL[®]
Radio Design Labs

SPECIALISTS IN PRACTICAL PRECISION ENGINEERING™

FLAT-PAK™ SERIES

Model FP-MR2

Message Repeater

- Repeating Single Message
- Music Quality Message Recording
- Up to 1.7 Minute Digital Message Storage
- External/Remote Message Actuation
- Interval Timer to Repeat Message Playback
- Background Music Input
- Automatic Voice-Over or Music Ducking

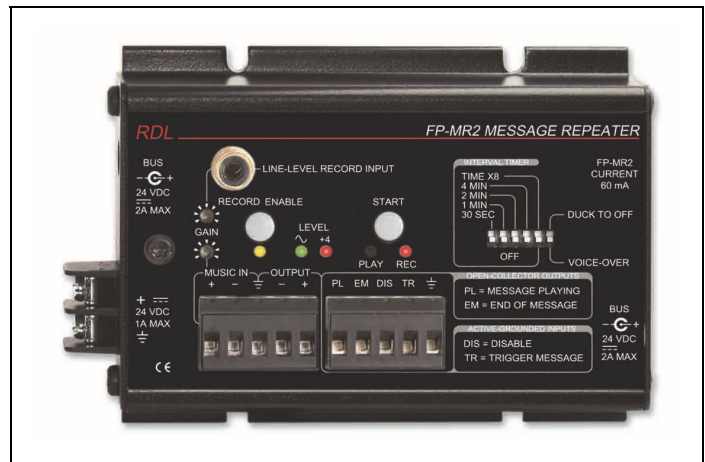

The FP-MR2 is part of the group of versatile FLAT-PAK products from Radio Design Labs. The unique FLAT-PAK case can be directly screwed or bolted to cabinets or shelves. Optionally available rack-mounting accessories permit single or multiple FLAT-PAK module mounting.

APPLICATION: The FP-MR2 is a message repeater that permits electronic storage of a single recording up to one minute forty seconds in duration. This message may be played back manually using an external contact closure to ground or using the front-panel **START** button. The message may also be played back periodically using the interval timer included in the FP-MR2. A balanced line-level music input allows background music to be connected and the associated input potentiometer allows the installer to set the music level. When message playback is triggered, the music is faded down. At the conclusion of the message, the music level fades back up. A front-panel DIP switch sets the music to fade under the message (-20 dB nominal) or completely off (used for messages containing music). The module output level is a nominal +4 dBu balanced. The output level is indicated on an RDL dual-LED VU meter which is used to set the proper music and recording levels.

The message may be recorded once, at installation, then played back repeatedly. The message may be re-recorded at any time and is retained when power is removed from the module. The recording input is a standard -10 dBV consumer level unbalanced phono jack. An input level trimmer is provided to set the correct recording level which is indicated on the dual-LED meter. The front-panel **RECORD ENABLE** pushbutton erases the message in memory and enables recording, indicated by the **RECORD ENABLE** LED. The module begins recording when the **START** button is pushed and continues until the button is released. The **REC** LED is illuminated during recording. An integral audio compressor maintains a consistent average recording level over 20 dB of input level variation without significant audible effect on the signal dynamics.

Message playback is triggered when the front-panel **START** button is pressed with the FP-MR2 *not* in the **RECORD ENABLE** mode. Playback may also be activated by a remote momentary closure to ground on the **TR** terminal or by using the internal interval timer. The external trigger causes the message to play each time the terminal is grounded. A **DIS** (disable) terminal is provided to prevent the module from ducking the music audio and playing the message. As long as the **DIS** terminal is grounded, the module will not play. When released, the module will play the next time it is triggered either externally or internally. Grounding the **DIS** terminal while a message is playing will abort the playback. If the internal timer calls for message playback while the **DIS** terminal is grounded, the message will play upon release of the terminal. While the module is playing, the **PL** (playing) output terminal is held low. This terminal is used to control other equipment, and is particularly useful for disabling another FP-MR2 in installations where FP-MR2s are connected in series for multiple repeated announcements. At the conclusion of each playback, the **EM** (end of message) terminal pulses to ground for >100 mS. This terminal may be used to trigger other equipment or additional FP-MR2 module playback. The internal interval timer is controlled by front-panel DIP switches. The time between messages is selected in 30 second increments from 30 seconds to 7.5 minutes. The selected increment is multiplied x1 or x8 for a maximum time interval of 60 minutes.

The FP-MR2 operates from ground-referenced 24 Vdc. Use the FP-MR2 individually, or combine it with other RDL products as part of a complete audio/video system.



RDL[®]
Radio Design Labs

SPECIALISTS IN PRACTICAL PRECISION ENGINEERING™

FLAT-PAK™ SERIES

Model FP-MR2

Message Repeater

Installation/Operation

Declaration of Conformity available from rdlnet.com.
Sole EMC specifications provided on product package.
Specifications are subject to change without notice.

RECORDING

- CONNECT AUDIO INPUT →
- ADJUST 'RECORD INPUT' GAIN USING LEVEL METER (GREEN LED BRIGHT, RED FLASHING OCCASIONALLY)
- PRESS 'RECORD ENABLE' BUTTON (HOLD 2 SECONDS) LED WILL FLASH WHILE ERASING OLD MESSAGE (IF ANY) WHEN LED GLOWS STEADY, UNIT IS READY TO RECORD
- PRESS AND HOLD 'START' BUTTON WHILE RECORDING NOTE: 'REC' LED WILL BE ON DURING RECORDING
- RELEASE 'START' BUTTON WHEN FINISHED; NOTE: 'REC' LED WILL GO OFF
- IF DESIRED, LISTEN TO YOUR MESSAGE USING THE CONNECTED POWER AMPLIFIER AND SPEAKERS (OR RDL PT-AMG2) BY MOMENTARILY PUSHING THE START BUTTON; NOTE: 'PLAY' LED WILL BE ON DURING PLAYBACK

SETTING MUSIC LEVEL

WHILE A MESSAGE IS NOT PLAYING, ADJUST MUSIC LEVEL USING VU METER INDICATION

The maximum required input current is 2 A with the maximum load current connected to the power bus output. Module may be powered from a current limited dc power supply of up to 3 A.

OR
24 VDC POWER SOURCE

BALANCED WIRING

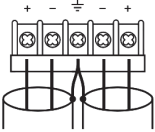

UNBALANCED WIRING

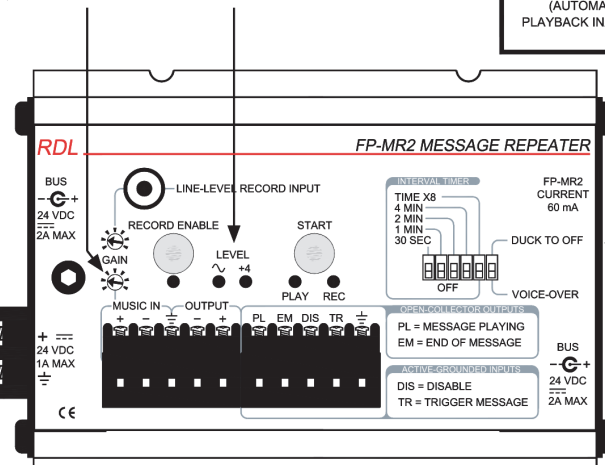
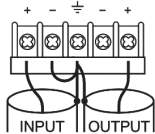

SETTINGS

DUCKING

MUSIC FADES UNDER MESSAGE DURING MESSAGE PLAYBACK (FOR VOICE-ONLY MESSAGES)

MUSIC FADES COMPLETELY OFF DURING MESSAGE PLAYBACK (REQUIRED FOR MESSAGES WITH MUSIC)

INTERVAL TIMER

ANY TIME SWITCH TURNS TIMER ON

SET TIME SWITCHES TO TOTAL DESIRED INTERVAL BETWEEN AUTOMATIC MESSAGE PLAYBACK; SET 'X8' TO MULTIPLY TIME SWITCH SETTINGS BY 8

TIMER OFF (AUTOMATIC PLAYBACK INACTIVE)

Power to Additional Flat-Pak Modules, Total Current Not to Exceed 2 A or Available Supply Current if less than 2 A.

NOTE: This equipment has been tested and found to comply with the limits for a Class B digital device, pursuant to part 15 of the FCC Rule. These limits are designed to provide reasonable protection against harmful interference in a residential installation. The equipment generates, uses and can radiate radio frequency energy and, if not installed and used in accordance with the instructions, may cause harmful interference to radio communications. However, there is no guarantee that interference will not occur in a particular installation. If this equipment does cause harmful interference to radio or television reception, which can be determined by turning the equipment off and on, the user is encouraged to try to correct the interference by one or more of the following measures:

- Reorient or relocate the receiving antenna
- Increase the separation between the equipment and receiver
- Connect the equipment into an outlet on a circuit different from that which the receiver is connected.
- Consult the dealer or an experienced radio/TV technician for help.

TYPICAL PERFORMANCE

Music Input

Input: 50 kΩ balanced or unbalanced
 Input Level (for +4 dBu out): -18 dBu bal. (-20 dBV unbal.) to +18 dBu bal. (+16 dBV unbal.)
 Frequency Response: 30 Hz to 40 kHz (+/- 1 dB)
 THD+N: < 0.05% (1 kHz)
 Noise below +4 dBu: < -70 dB (unity gain)
 CMRR: >70 dB (50 to 150 Hz)

Recording Input

Input: 10 kΩ unbalanced
 Input Signal: -20 dBV to 0 dBV
 Frequency Response: 80 Hz to 12 kHz (+/- 1.5 dB)
 Noise below +4 dBu: < -65 dB

Output: 150 Ω balanced or 75 Ω unbalanced
 Output Level: +4 dBu nominal

Control

Control Inputs (2): TRIG and DISABLE, Pull to ground, 1 mA
 Control Outputs (2): Open-collector @ 25 mA

Power Requirement:

24 Vdc @ 60 mA, Ground-referenced
 Width: 3.25 in. (8.26 cm); Length: 5.00 in. (12.70 cm); Height: 1.36 in. (3.46 cm)

Radio Design Labs Technical Support Centers

U.S.A. (800) 933-1780, (928) 778-3554; Fax: (928) 778-3506

Europe [NH Amsterdam] (+31) 20-6238 983; Fax: (+31) 20-6225-287