

Overview

The DXR10 mk3 is a 2-way, bi-amped, powered loudspeaker and is the most compact model in the series, delivering exceptional clarity, precision, and a powerful 132 dB SPL output. Thanks to its compact, lightweight enclosure, it can function as a versatile utility speaker suitable for a wide variety of environments. Advanced DSP capabilities and a dedicated remote app add significantly more flexibility, with powerful features that enhance the overall user experience.



Features

- 10" LF + 1.75" HF proprietary high-durability speaker units
- The large-diameter horn secures directivity control across a wide frequency range
- Optimized port positioning reduces standing wave effects
- Lightweight, high-performance, form-injection molded enclosure with a symmetrical, functional design
- Newly developed 2000W Class-D amplifier
- FIR-X™ tuning, provides FIR filtering and corrective EQ, minimizing phase distortion
- Drive Motion Calibration™, corrects the motion of the LF unit, producing a more linear low-frequency sound with high reliability
- DSP modes tailored for specific arrangements or applications. In particular, FOH/MAIN and MONITOR modes have an automatic setting function "AUTO V/H POSITION"
- Can be controlled remotely via an iOS or Android device using the dedicated D-Remote app
- Compatible with audio streaming via Bluetooth® device
- Intelligent feedback suppressor automatically eliminates unpleasant feedback
- Optional UB-DXRDR10A U-bracket allows both for vertical or horizontal use
- Optional SPCVR-DXR103 speaker cover protects speakers from rigors of equipment transport, lengthy storage, or outdoor performances
- Rigging points for use with eye bolts
- Dual-angle pole sockets offer both 0° or a -7° down tilt

Specifications

General Specifications

Speaker type	2-way, Bi-amped Powered Speaker, Bass-reflex	
Frequency range (-10 dB)	53 Hz - 20 kHz	
Coverage area	H90° x V60°	
Crossover	1.8 kHz: FIR-X tuning™ (linear phase FIR filter)	
Maximum Output Level (Measured peak, IEC noise @ 1 m)	132 dB SPL	
Components	LF	Diameter: 10" cone, Voice Coil: 2.5"
	HF	Diaphragm: 1.75", Type: 1" throat compression driver
Amplifier class	Class-D	
Power rating	PEAK	2000 W (LF:1700 W, HF:300 W) *1
	RMS	1000 W (LF:850 W, HF:150 W) *2
Cooling	Fan Cooling, 5 Speeds	
Power consumption	120 W (1/8 power), 35 W (Idle)	
Power requirements	100 V - 240 V 50/60 Hz	
A/D D/A Converters	32 bit/96 kHz Sampling	
Processors	HPF: OFF, 50 Hz - 118 Hz, 12 dB - 48 dB/Oct.; DSP-MODE: FOH/MAIN, MONITOR, DJ, LIVE MUSIC, SPEECH, OFF	
I/O	Inputs	INPUT1: Combo x1, Impedance 20 kΩ (balance) 10 kΩ (unbalance), Maximum Input Level +24 dBu; INPUT2: Combo x 1, Impedance 6 kΩ (balance) 3 kΩ (unbalance), Maximum Input Level +24 dBu (Line) -6 dBu (Mic)
	Outputs	OUTPUT1: XLR3-32 THRU; OUTPUT2: XLR3-32 THRU or DSP OUT
	Bluetooth®	Ver. 5.0, A2DP (SBC, AAC), Class 1
	Control and others	D-Remote (iOS/Android app)
Cabinet material	Plastic (PP)	
Finish	Black	
Handle	Top x1	
Pole socket	Φ35 mm x 2 (Bottom, 0° or -7°)	
Rigging	Top x 2, Rear x 1 (Fit for M8 x 15 mm Eyebolts), Bottom x 2, Side x 2 (Fit for M8 x 25 mm UB-DXRDR10A)	
Floor Monitor Angle	55°	
Dimensions	W	310 mm (12.2")
	H	502 mm (19.8")
	D	310 mm (12.2")
Net weight	14.5 kg (32.0 lbs)	
Options	U-bracket: UB-DXRDR10A, Cover: SPCVR-DXR103	

*1: Total peak power of individual outputs. Measured by recording the highest peak-to-center voltage produced at minimum load impedance, with protection released.

*2: Measured by recording the highest RMS voltage produced at minimum load impedance, with protection released.

Dimensions

Unit: mm (inch)

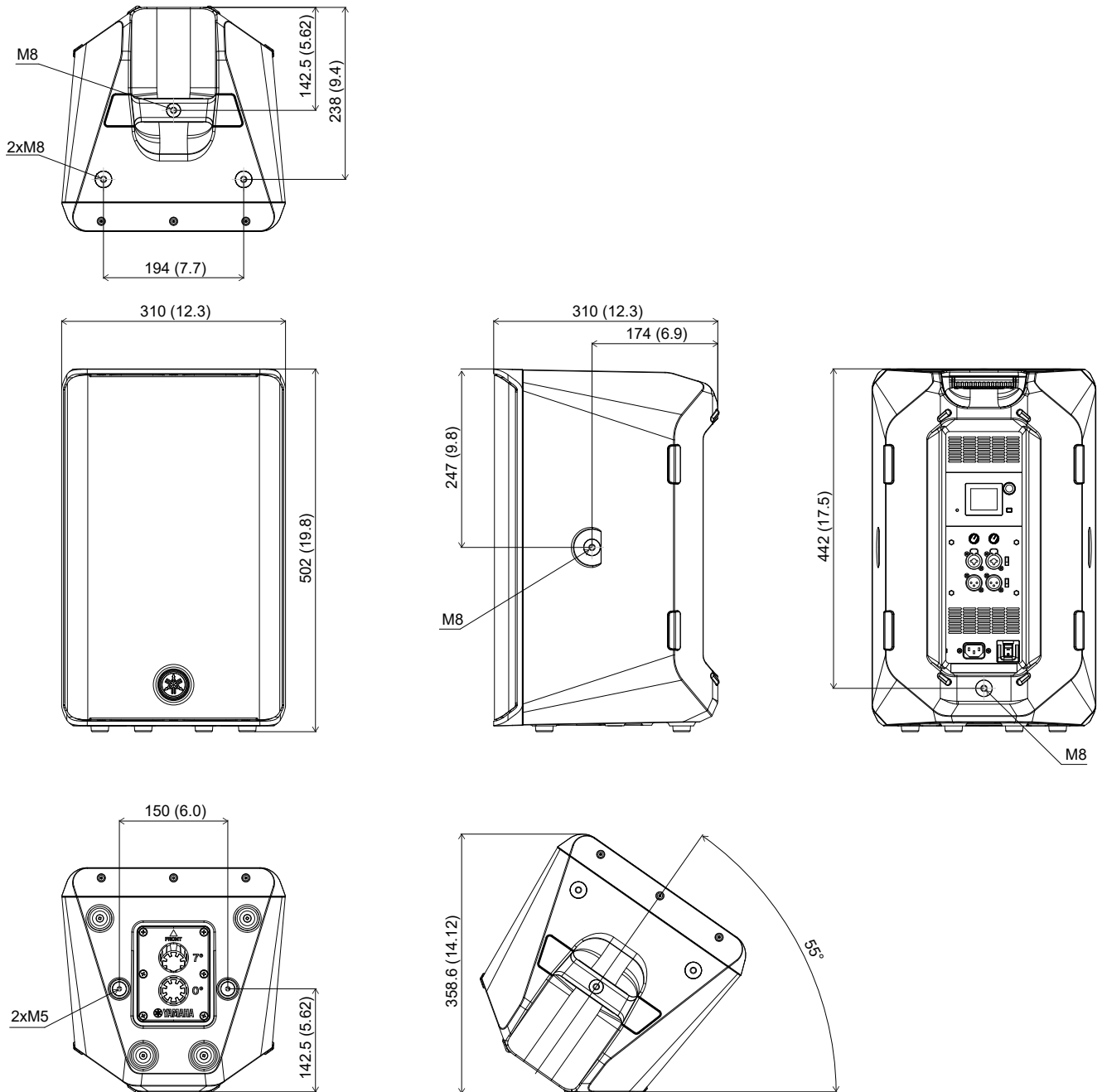

Options

- U-bracket UB-DXRDHR10A
- Cover SPCVR-DXR103

Architectural and Engineering Specifications

The Yamaha DXR10 mk3 shall be a powered loudspeaker for sound reinforcement applications. The loudspeaker shall be a full-range, two-way, bi-amplified, bass-reflex type with configurable built-in digital signal processing. The loudspeaker shall have one 10" cone low-frequency transducer with a 2.5" voice coil, and one 1" throat high-frequency compression driver with a 1.75" polyimide diaphragm. The total peak power rating shall be 2000 watts, with a total RMS power rating of 1000 watts (bi-amplified, with 850 watts delivered to the LF transducer and 150 watts delivered to the HF transducer). The loudspeaker's amplifiers shall be efficient class-D types, with idle power consumption of 35 watts. The crossover frequency shall be 1.8 kHz using a linear phase FIR filter. The loudspeaker shall be capable of meeting the following performance criteria: reproduction frequency range shall be 53 Hz to 20 kHz (-10 dB), and maximum output SPL shall be 132 dB (peak, pink noise @ 1m). Coverage angles shall be 90° horizontal and 60° vertical.

Two XLR/TRS combo connectors shall be provided for line-level analog audio input. Input 2 shall be switchable to mic-level. Two XLR connectors shall be provided for analog audio THRU output, one of which shall be switchable for DSP output. Bluetooth® connectivity shall be provided for stereo audio input from mobile smart devices.

The loudspeaker shall provide digital signal processing at a sample rate of 96 kHz, using 96 kHz analog-to-digital and digital-to-analog converters. Digital signal processing functions shall be accessible via an LCD display panel and include delay, input and output level adjustment, mute, HPF, 4-band input EQ, 6-band output EQ, ducker, feedback suppressor and link mode. A feature called D Mode shall be provided for switching dynamic multiband compression characteristics to suit FOH, Monitor and other usage. Panel lock, panel setup and password protection features shall also be provided. Digital signal processing shall further be used to provide system-wide protection. Preset setups shall be provided, with on-board memory for internal user setting storage. A smart device app called D-Remote shall be available to control the loudspeaker's DSP functions and manage preset memories via Bluetooth® control.

The loudspeaker enclosure shall be constructed of form-injection molded black plastic, and shall allow for two angles of pole mounting as well as symmetrical floor monitor use, with a 55° angle. The front grille shall be made of black matte powder coated steel and shall not include any visible mounting screws on the front panel. Rigging points shall be provided for use with standard eyebolts, and optional U Brackets will offer a variety of mounting configurations. The loudspeaker cabinet shall include one handle for manual lifting. The dimensions of the loudspeaker shall be 310 x 502 x 310 mm (W x H x D). The weight shall be 14.5 kg.

Block Diagrams

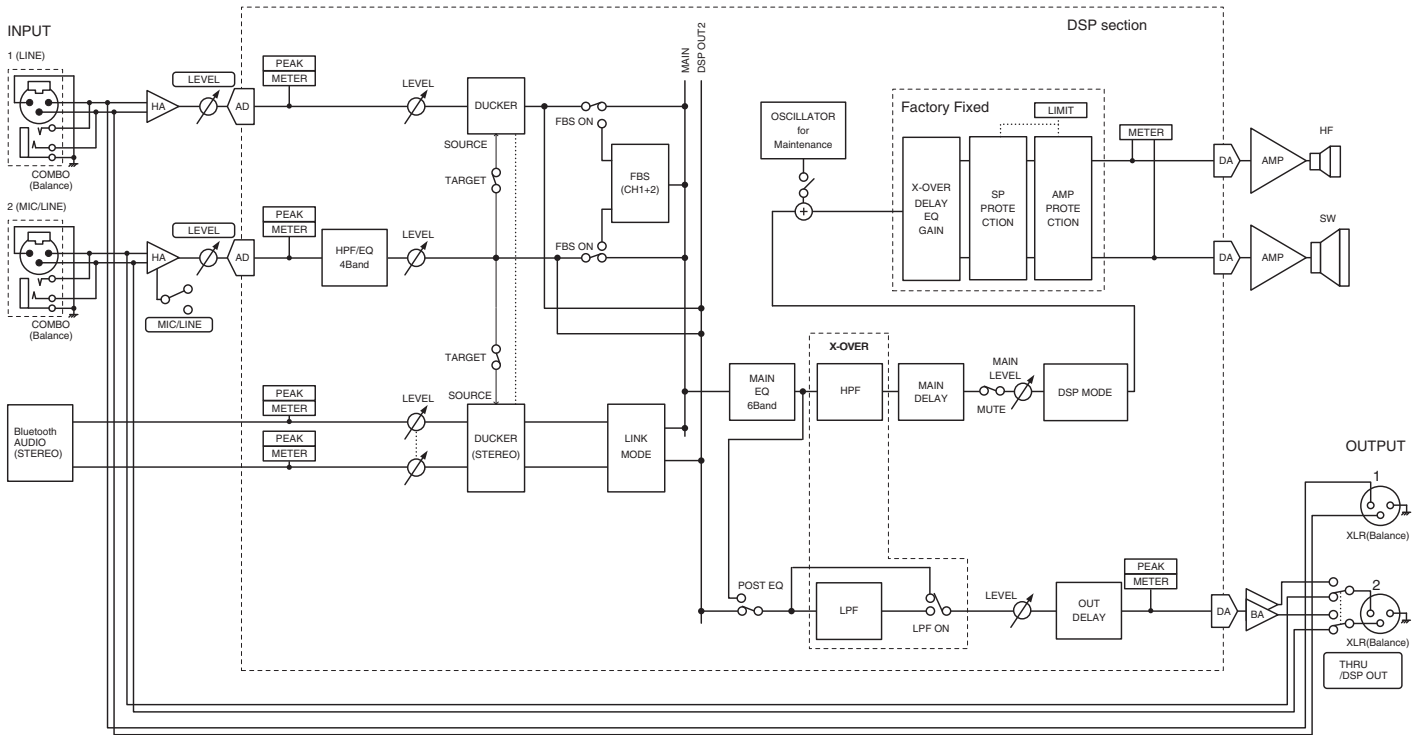

Frequency Response

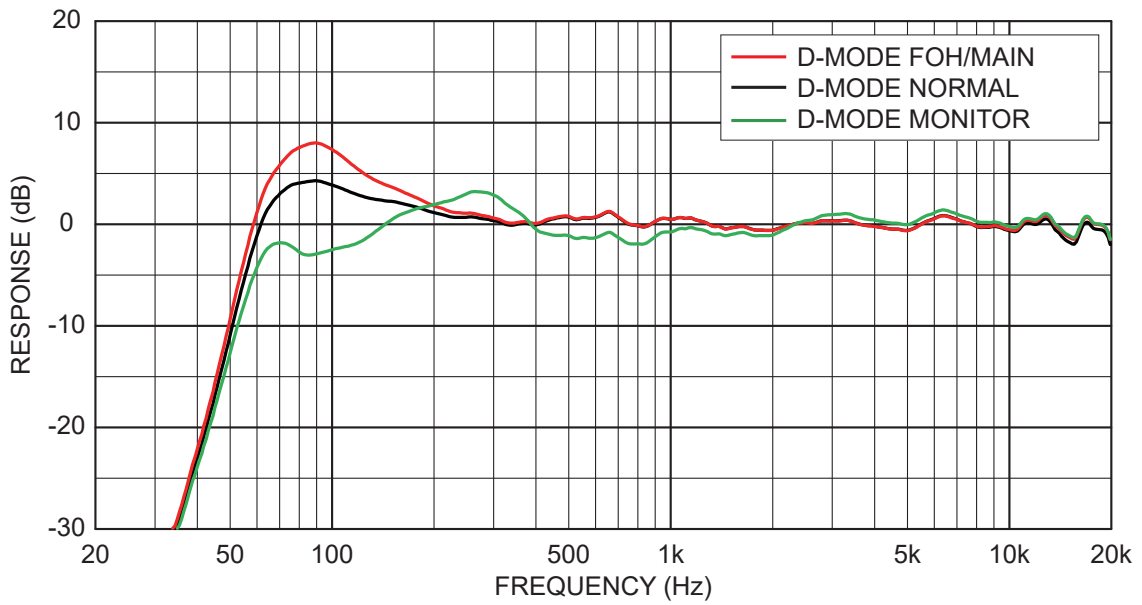

Phase Response

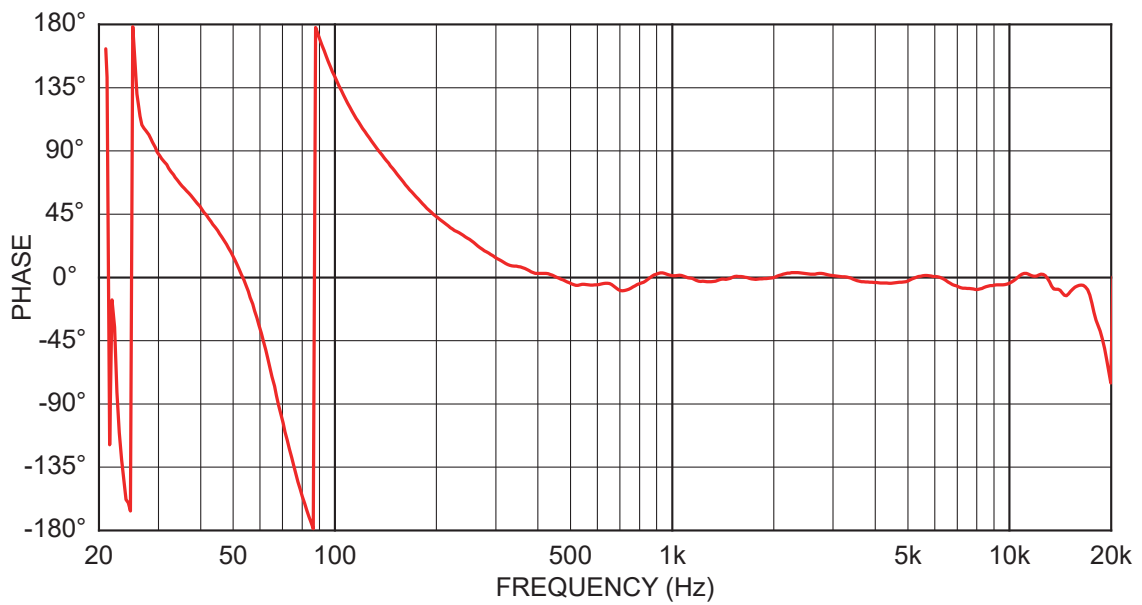

Horizontal Polar Plots

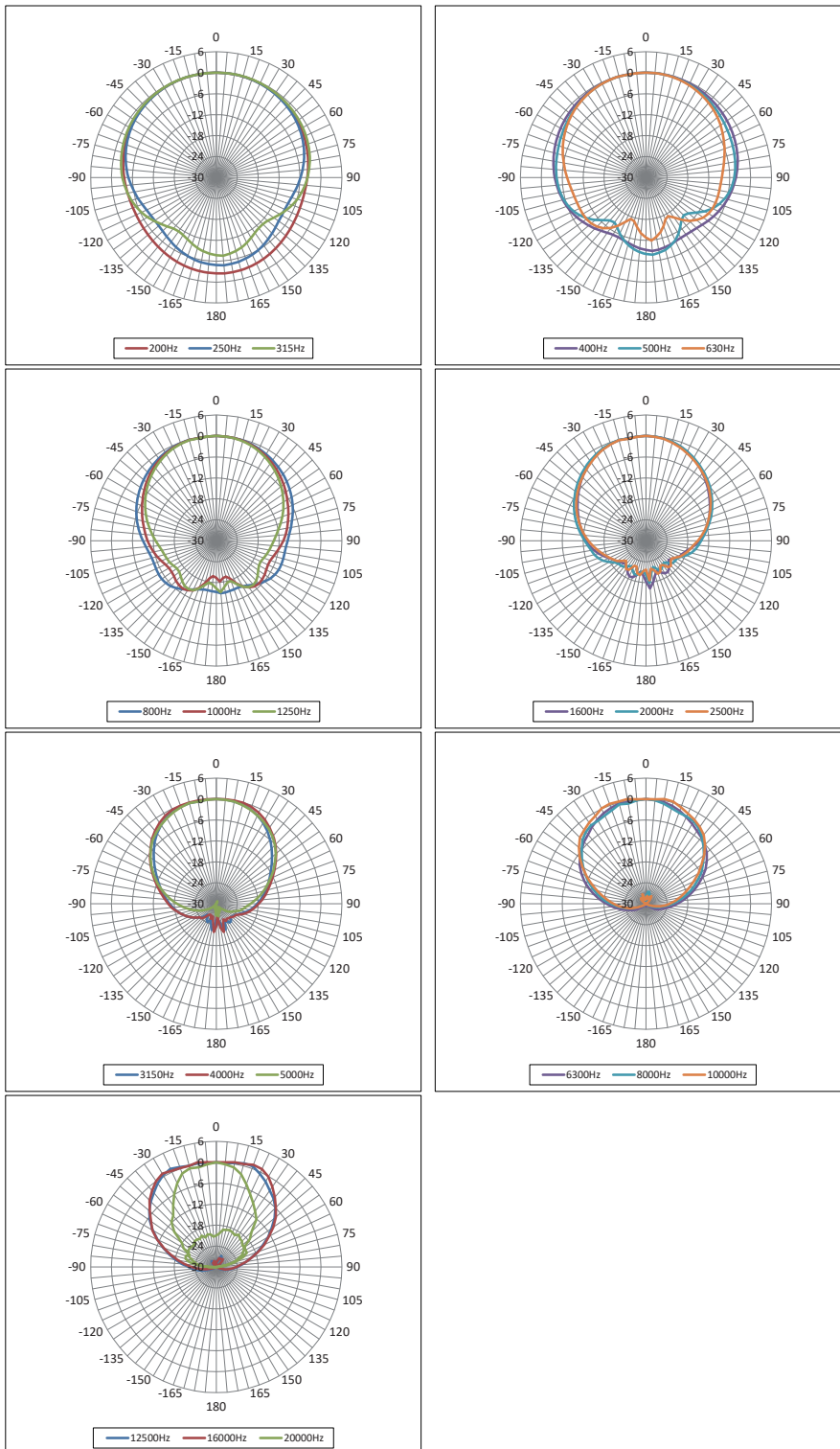

Vertical Polar Plots

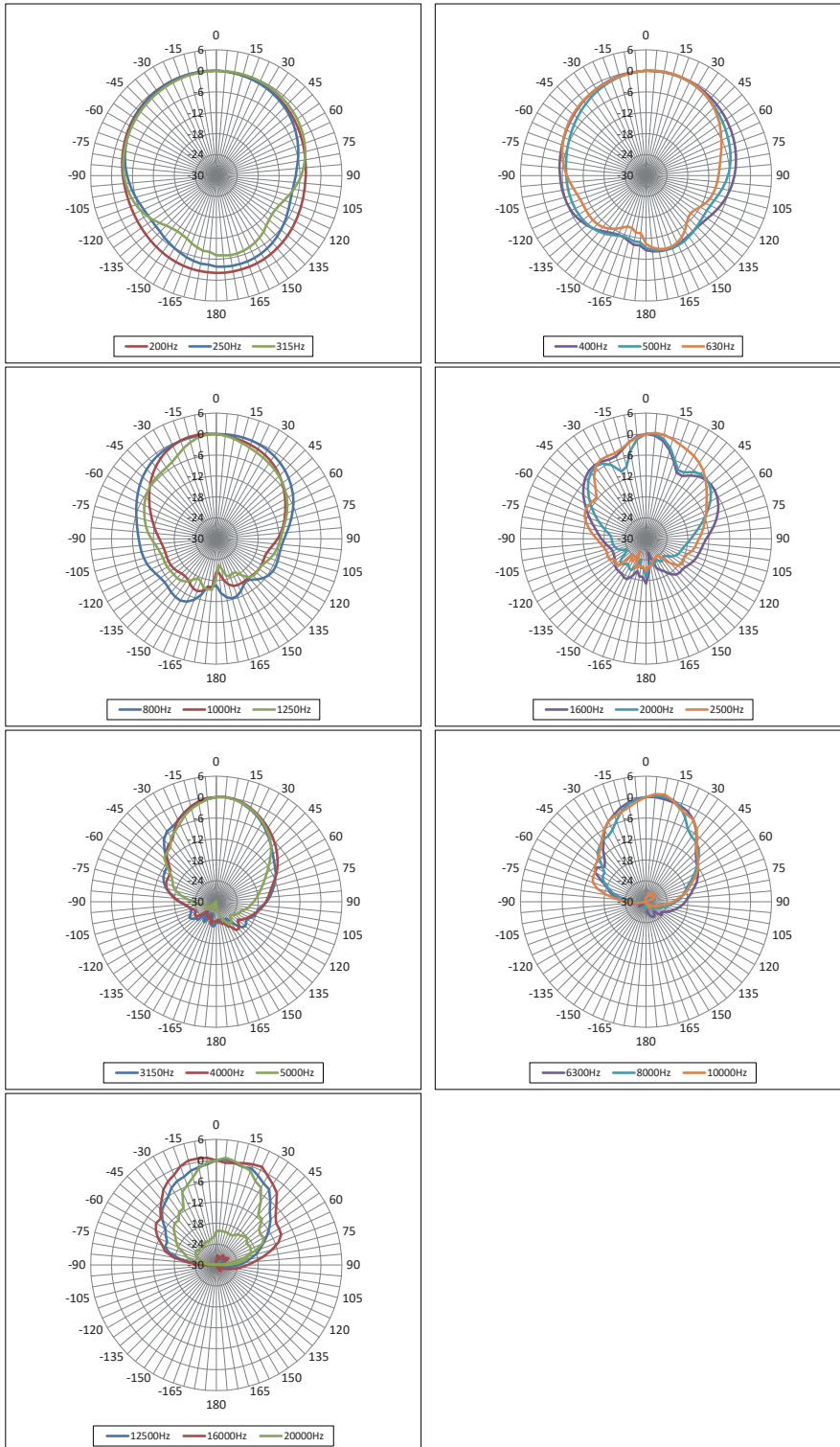

*All information subject to change without notice.

*All trademarks and registered trademarks are property of their respective owners.

Created in April, 2026

YAMAHA CORPORATION
P.O.BOX 1, Hamamatsu Japan