

Rocknustics®

ULTRA-FIDELITY OUTDOOR SPEAKERS



ESCAPE SERIES | OWNER'S MANUAL

ESCAPE SERIES | OWNER'S MANUAL

Please read the following instructions carefully before installing your Rockustics® Rock speaker. If you have any questions regarding installation that are not answered in the following directions, please contact your local sound contractor or the Rockustics®/MSE Audio® technical support team. Contact information can be found on the back of the manual.

Optimizing Speaker Placement for Best Sound

All Rockustics speakers can generate a high SPL (sound pressure level). Be ready to rock, but be considerate of your neighbors! Maximum acoustic performance should be an important factor in determining speaker placement. Here is how to achieve it:

- 1) Establish where the most likely or average listening position will be.
- 2) The speakers should be placed at or close to the same distance from that point.
- 3) The actual distance between the listening position and the location of the speakers is not critical. However, keep in mind that as the distance between listening area and speaker is increased, there will be a noticeable decrease in perceived volume.
- 4) Be sure to confirm amp power matches the power rating on the speaker. Over-driving the speaker can lead to permanent damage that is not covered under warranty.

Optimizing Aesthetics with Speaker Placement

All Rockustics products are designed with a boost in high frequency response to accommodate for placement near plants and other landscaping features. Feel free to position the product within your landscaping, camouflaged near bushes or shrubs. Rockustics products strive to blend into the natural aesthetic of their surroundings.

Be sure to account for the wires which will run from the rock to your stereo or audio source. Camouflage wires by running them an inch below ground level when possible.

Cautions and Maintenance

All Rockustics Rock Series speakers are sealed and fully weatherproof. However, DO NOT place speakers where the grille will be in the path of a sprinkler system. Sprinklers typically have a high water pressure level that can damage speaker cones if hit directly.

DO NOT place soil or wood chips over the speaker grille. If the grilles accumulate a build up of soil, the speaker may become damaged. If build up does occur, simply rinse the grille with a garden hose set to a low pressure level. Accumulated soil may also promote undesired insect traffic into the speaker. Insects may eat through the speaker surround. Chemical sprays may also cause damage to the rubber of the speaker surround. This includes bug spray, deck sealant, some fertilizers and oil based products. Speakers MUST be covered when applying these treatments or chemicals in your yard.

Cautions and Maintenance (Continued)

For environments that get snow and ice during the winter months, be sure to check that the openings and woofer cone are clear and there is no hard-packed snow or ice built up in these areas before playing. If there is ice or snow present on the cone, use a hair dryer set on a low setting to melt it away. If the speakers are not going to be used during winter months, it is recommended that they either be disconnected and brought indoors, or covered with a plastic bag to help protect the speaker components.

Wiring for Low Impedance Applications

If using 8 ohm wiring instead of 70V, only use tap position 1 on Periscope units. Subscape units require specific preparation for 8 ohm use, outlined in step 5 of the Subscape instructions section. Use the supplied silicone wire nut to connect the positive (+) leads of the speaker and input wires. Repeat this step with the negative (-) leads. Rockustics recommends using 14ga or heavier direct burial cable for the connection between the amplifier and the speakers.

Wiring for 70V/100V Applications

For speakers with transformers, use [Diagram C and D](#) to find the proper wire selection for your desired tap setting. Once the desired tap setting is confirmed, trim the unused wires to minimize corrosion. For harsh and wet environments, it is recommended to apply a bead of silicone to the end of the unused wires for added protection.

If daisy-chaining, follow wire preparations as outlined in the [Basic Wiring](#) section. Review [Diagram F](#) for a typical daisy-chain wiring system for 70V and 100V applications. Be sure to connect the wires going to the next speaker in the chain as shown in [Diagram E](#). There should be three pairs of wires at each speaker, but the last speaker in the chain will only have two pair. Follow standard protocol for polarity and make sure all units are wired with the same polarity.

Subscape Tap Wire Key	Wire Color	Subscape 8	Subscape 10	Subscape 12
	Black	70V-Common	70V-Common	70V-Common
	Yellow	150W	250W	300W
	Blue	75W	125W	150W
	Brown	38W	63W	75W

Diagram C

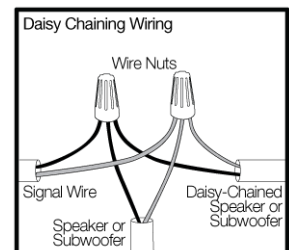

Diagram E

Periscope Tap Wire Key	Switch Position	Periscope 4	Periscope 6
	I	8 Ohm	8 Ohm
	II	25W	50W
	III	13W	25W
	IV	7W	13W
	V	4W	7W

Diagram D

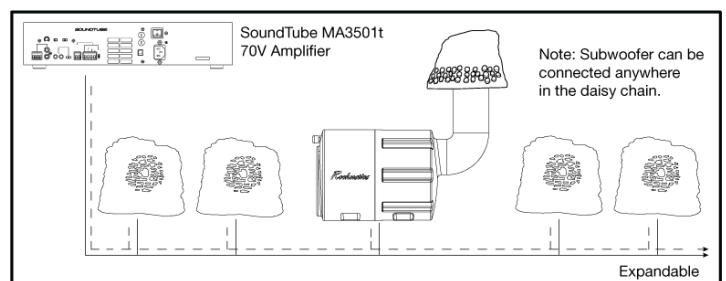
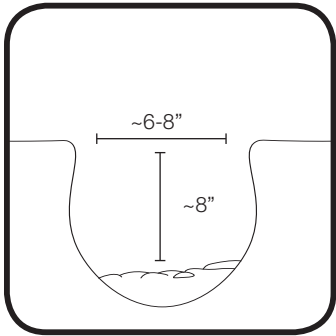

Diagram F

PERISCOPE INSTRUCTIONS



1. Digging

Dig a hole sufficient to bury the speaker(s) to the correct depth (noted above) in the precise location where the speaker will be placed.

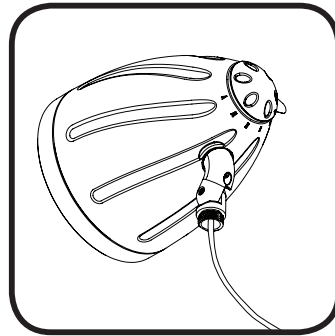

2. Strip Wire

Strip and prepare wire ends for your speaker configuration.

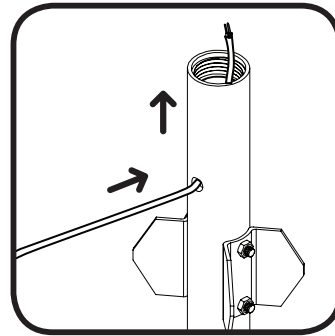

3. Thread Wire

Pass the wire from the amp through the side hole in the mounting spike and out the top end. Repeat this process if daisy-chaining. Do NOT pass the speaker wire(s) out of the bottom of the mounting spike.

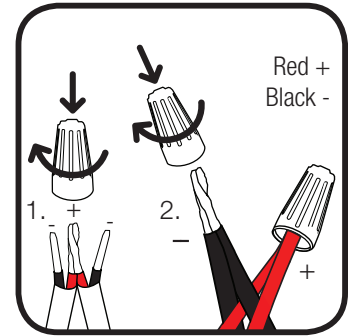

4. Trim Wire

Trim the wire to the appropriate length and connect the positive (+) leads on the input wire with the wire nut. If daisy-chaining, connect the positive (+) wire for the next speaker in the chain. Repeat for negative (-) leads.

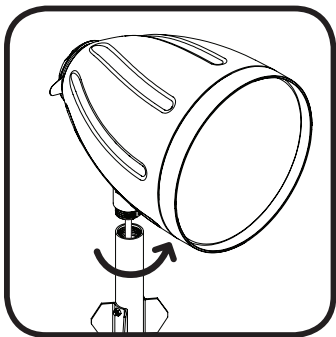

5. Screw on Spike

With the speaker wires inside the spike, begin threading the speaker until it's tight. Gently pull on the speaker wires coming out of the side to remove any excess wire.



6. Test

Fully wire the rest of your system and test to make sure sound is coming from each unit.

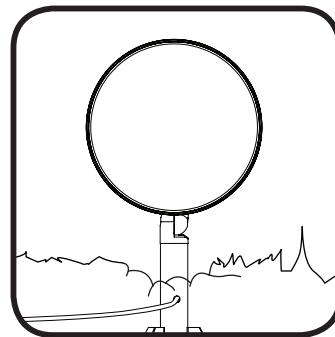

7. Position Speaker

Position the speaker in the desired direction in the hole. The speaker should be deep enough that the wire(s) can be buried at least 1" below the ground. Backfill the hole.

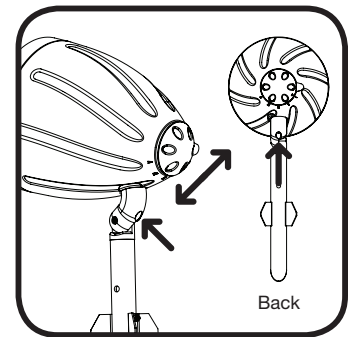

8. Fine-Tune Aiming

Angle the speaker in your desired position with the allen wrench. Loosen screw in the bottom of the gooseneck and gently rotate. Re-tighten when angled properly.

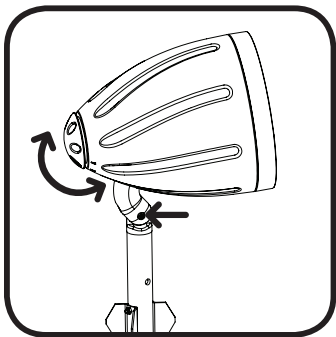

9. Vertical Aiming

Adjust angle by loosening the screw on the side of the mounting bracket. Adjust speaker to the desired angle and re-tighten screw. Do NOT angle speaker more than 45°.

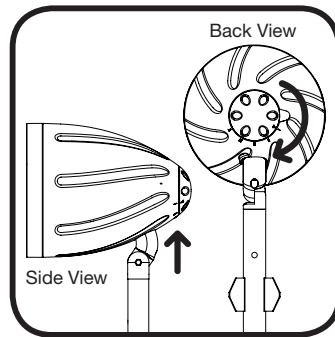

10. Tap Switch Settings

See the tap switch key on page 3 to determine which tap power setting corresponds to the markings on the exposed tab. Push the tap switch onto the speaker and select accordingly.

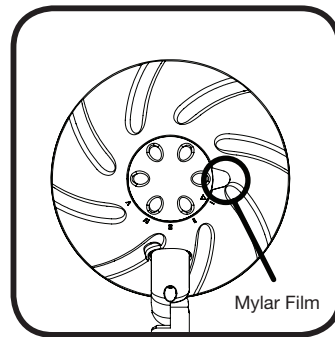

11. Mylar Film

Remove the mylar film from under the tap switch knob by pulling on the exposed tab. Push the tap switch onto the speaker to lock into position.

Note:

To reset the tap position after the knob has been locked in place, gently pry the tap switch knob 1/8" from speaker. Re-position the tap switch to the desired setting and then push the knob back in place to be locked in its new position. If desired, the tap switch locking mechanism may be permanently disabled by cutting off the short pin on the back of the speaker. Simply remove the tap knob, cut off the locking pin on the back of the speaker and replace the knob.

SUBSCAPE INSTRUCTIONS

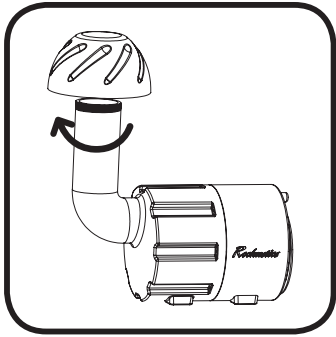

1. Install Cap

Install the cap by threading it onto the end of the port tube clockwise.

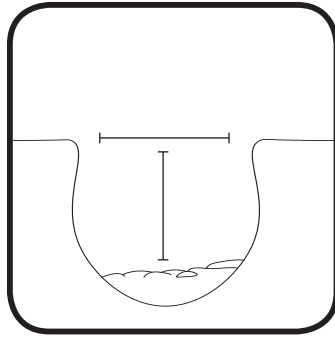

1. Digging

Dig a hole sufficient to bury the Subscape so that there is 3-5" clearance between the bottom of the port and the ground level. Be sure to account for several inches of gravel at the bottom to assist with drainage.

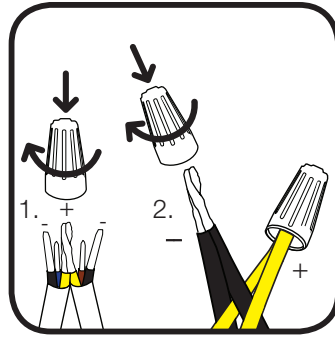

3. 70V Applications

For 70V (or 100V) applications, select the appropriate tap wires from the chart on page 3 and connect them to the input wire from the amp. Skip to step 5 if using 8 ohm.

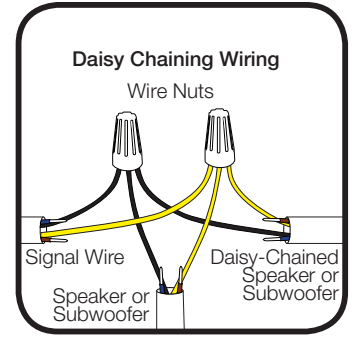

4. Daisy Chaining

If daisy-chaining, be sure to also connect the wires going to the next speaker in the chain. Follow standard protocol for polarity and make sure the subwoofer is wired with the same polarity as the Periscope units.

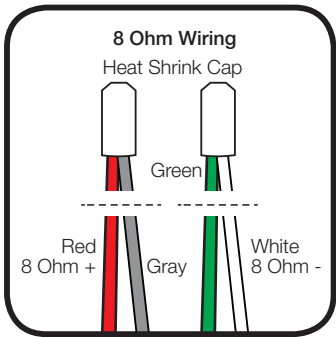

5. 8 Ohm Operation

Locate the red, gray, green, and white wire pairs and cut off the heat shrink cap on each pair. Use the supplied wire nuts and connect the positive (+) lead from the amp to the red wire and connect the negative (-) lead from the amp to the white wire. Do not use the gray or green wire. Disregard if using 70V Wiring.

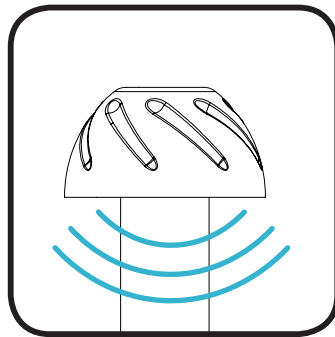

6. Test

Fully wire the rest of your system and test to make sure sound is coming from each unit.

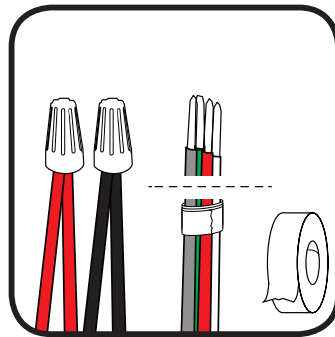

7. Trim Wires

Trim unused wires on the subwoofer and wrap the loose ends with electrician's tape or a suitable alternative to protect the bare wires from corroding.

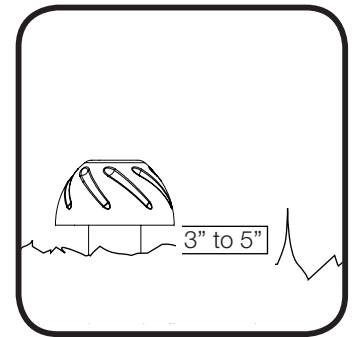

8. Complete Install

Place subwoofer in hole and fill. Leave 3-5" of space from the bottom of the cap to the ground.

Applicable Models

Periscope™ 4

Periscope™ 6

Subscape™ 8

Subscape™ 10

Subscape™ 12