

TABLE OF CONTENTS

1. SAFETY PRECAUTIONS	2
2. GENERAL DESCRIPTION	3
3. FEATURES	3
4. NOMENCLATURE AND DIMENSIONS	3
5. SYSTEM EXAMPLE	4
6. INSTALLATION	5
7. WIRING	7
8. CABLE CONNECTION TO TERMINAL CONNECTOR	8
9. SPEAKER INSTALLATION	9
10. REMOVING THE SPEAKER FOR MAINTENANCE	11
11. SPECIFICATIONS	12

Thank you for purchasing TOA's In-Ceiling Subwoofer.
Please carefully follow the instructions in this manual to ensure long, trouble-free use of your equipment.

1. SAFETY PRECAUTIONS

- Be sure to read the instructions in this section carefully before use.
- Make sure to observe the instructions in this manual as the conventions of safety symbols and messages regarded as very important precautions are included.
- We also recommend you keep this instruction manual handy for future reference.

Safety Symbol and Message Conventions

Safety symbols and messages described below are used in this manual to prevent bodily injury and property damage which could result from mishandling. Before operating your product, read this manual first and understand the safety symbols and messages so you are thoroughly aware of the potential safety hazards.



WARNING

Indicates a potentially hazardous situation which, if mishandled, could result in death or serious personal injury.



CAUTION

Indicates a potentially hazardous situation which, if mishandled, could result in moderate or minor personal injury, and/or property damage.



WARNING

- Leave the installations to your TOA dealer because the installation requires expert knowledge. Improper installation may cause the unit to fall, resulting in personal injury and/or property damage.
- Install the unit in a location that can structurally support the weight of the unit and its mounting hardware. Doing otherwise may result in the unit falling down and causing personal injury and/or property damage.
- Do not use other methods than specified to mount the unit. Extreme force is applied to the unit and the unit could fall off, possibly resulting in injuries.
- Attach the safety wire to the unit. If not attached, unit could fall off, resulting in personal injury.
- Tighten each screw securely. Ensure that the unit has no loose joints after installation to prevent accidents that could result in personal injury.
- Do not push speaker surface when installation unit to ceiling. Resulting in unit damage.

- Use the specified mounting hardware in combination. Doing otherwise may cause the unit or component to fall off, resulting in personal injury.
- Should the following irregularity be found during use, immediately stop operating the unit and contact your nearest TOA dealer. Further attempt to use under this condition may cause fire or electric shock.
 - If you detect smoke or a strange smell coming from the unit
 - If no tone sounds



CAUTION

- Avoid installing the unit in humid or dusty locations, in locations exposed to the direct sunlight, near the heaters, or in locations generating sooty smoke or steam as doing otherwise may result in fire or electrical shock.
- Do not operate the unit for an extended period of time with the sound distorting. This is an indication of a malfunction, which in turn can cause heat to generate and result in a fire.
- Avoid touching the unit's sharp metal edge to prevent injury.

2. GENERAL DESCRIPTION

The FB-3862CU-AM is a flush-mount ceiling subwoofer assembly for low frequency enhancement of distributed loudspeaker systems. A 60W 70/100V transformer is included, and the bandpass design eliminates the need for a bi-amplified system. The FB-3862CU-AM has low impedance (8Ω) bypass that is suited to applications that include electronic crossovers and dedicated low impedance power amplifiers.

3. FEATURES

- 8" long excursion low frequency driver for great bass response.
- 100W continuous, 200W peak power handling.
- Transformer taps for 70V, 100V and Low Impedance (8Ω) Bypass accessible behind the grille.
- UL1480A UEAY/UEAY7 certified for general signaling, and suitable for use in air-handling spaces.
- The mounting C-ring, tile rails and cutout template sheet are included.
- Removable grille for custom painting.
- Service eyebolts for safety wire installation.

4. NOMENCLATURE AND DIMENSIONS

[Front]

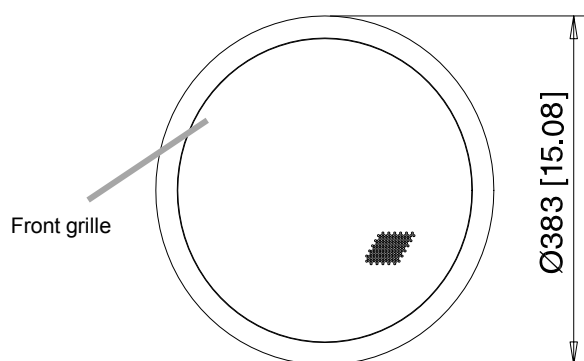

[Side]

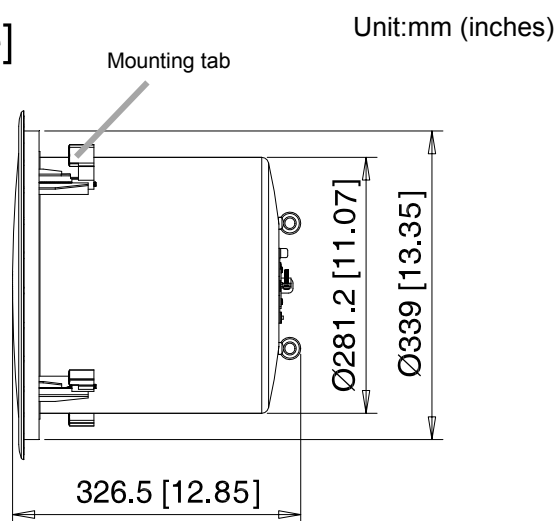

Unit:mm (inches)

[Rear]

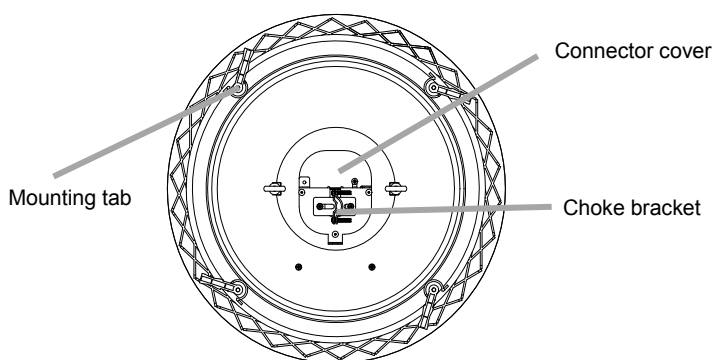

[Ceiling mounting]

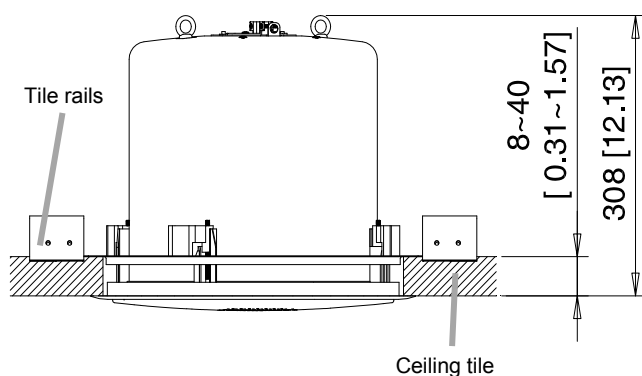

5. SYSTEM EXAMPLE

Example 1- 70V system (one power amplifier)

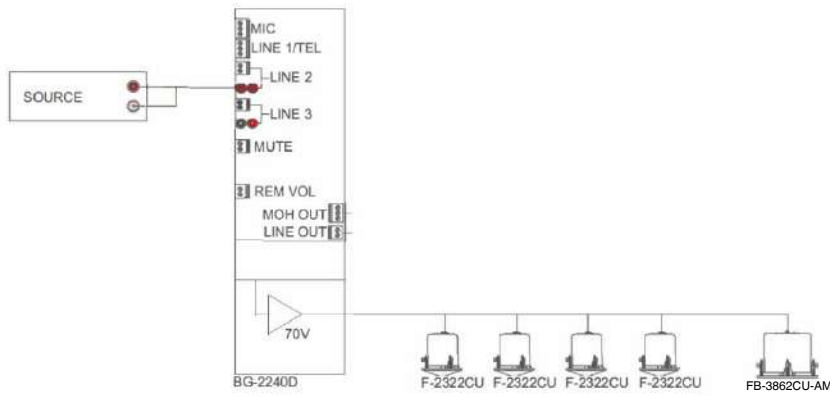

Example 2- Bi-amplified mono 70V system

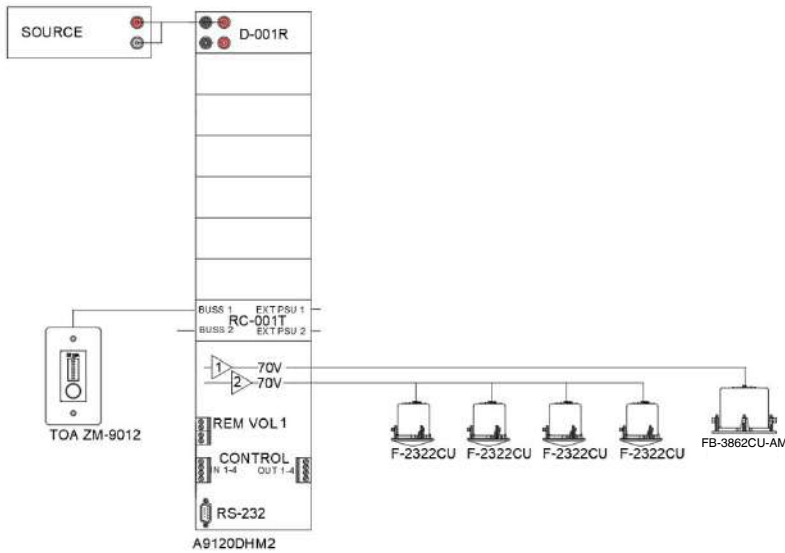

Example 3- Bi-amplified stereo low impedance system

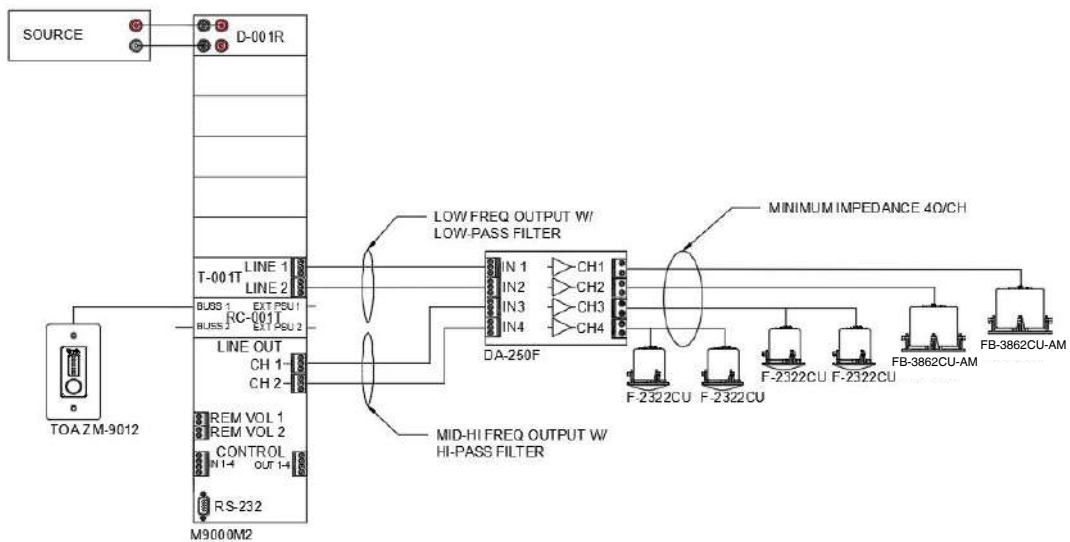

6. INSTALLATION

[Installation view on Drop Ceilings]

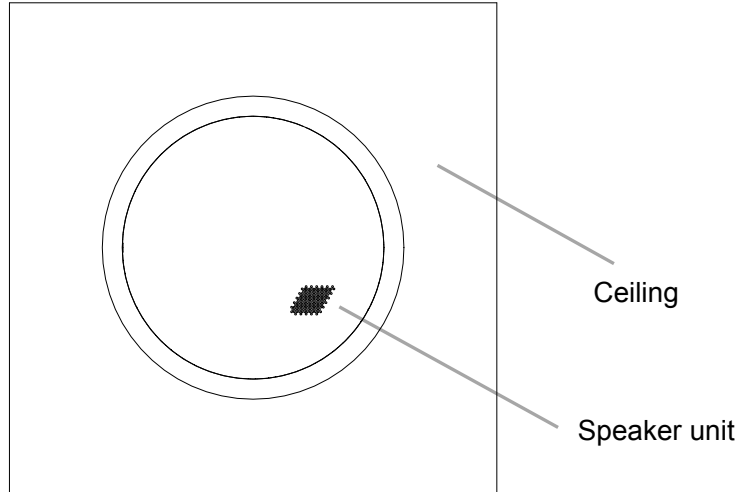

WARNING

This speaker must be installed in accordance with local building codes using support and safety cables attached to building structure. Failure to properly install these support and safety cables can lead to serious injury to persons or property. Always use load rated stranded steel cable or equal for support and safety cables. Place the supplied tile rails above the ceiling with the edge triangle parts are catching the T-grids in case the ceiling tile accidentally falls off.

Prior to installation- make sure that you have all the components from the carton, plus safety cables and attachment hardware (not included). There are two separate cartons (shipped together) that contain the loudspeaker assembly and mounting accessories-

FB-3862CU-AM loudspeaker with grill

Installation cutout template

Support ("C")ring

Support rails (qty 2) in a separate box

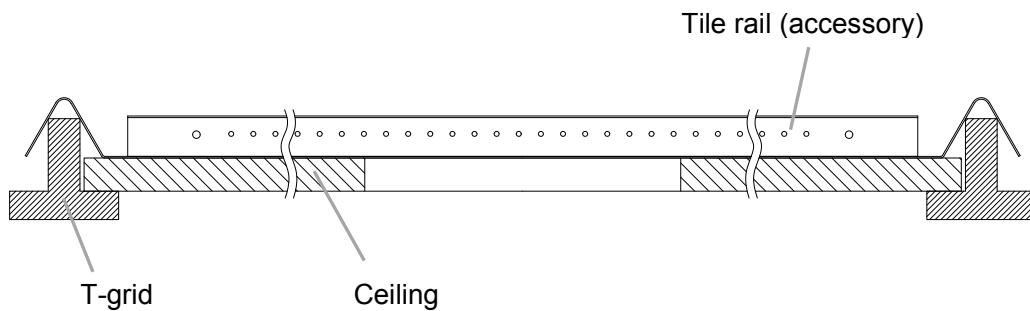

[Installation Procedures]

Step 1. Place the tile that will be used for the speaker finished side down on a clean flat surface. Using the template, cut a $\text{Ø } 350\text{mm}$ (13.8") diameter hole.

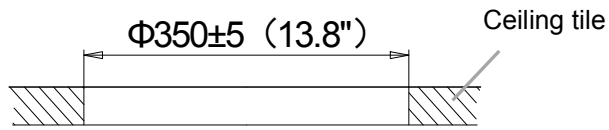

Step 2. Install mounting hardware on the ceiling.

2-1. Place the supplied tile rails on the 2-foot tile as shown below.

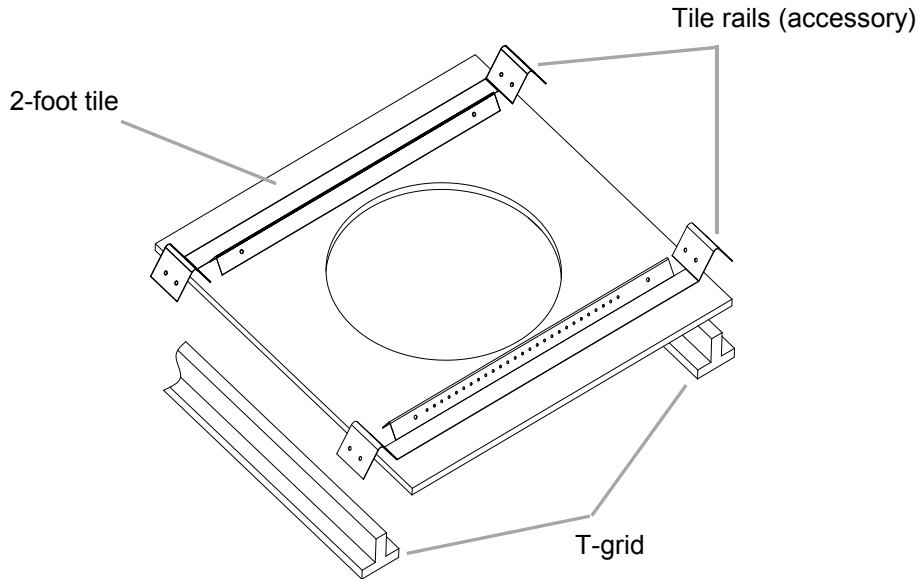

2-2. Place the support ring over the hole. Insert the tile supports into the C-ring grooves. Adjust the position of the assembly as required, then fix the tile rails to the support ring using the provided screws.

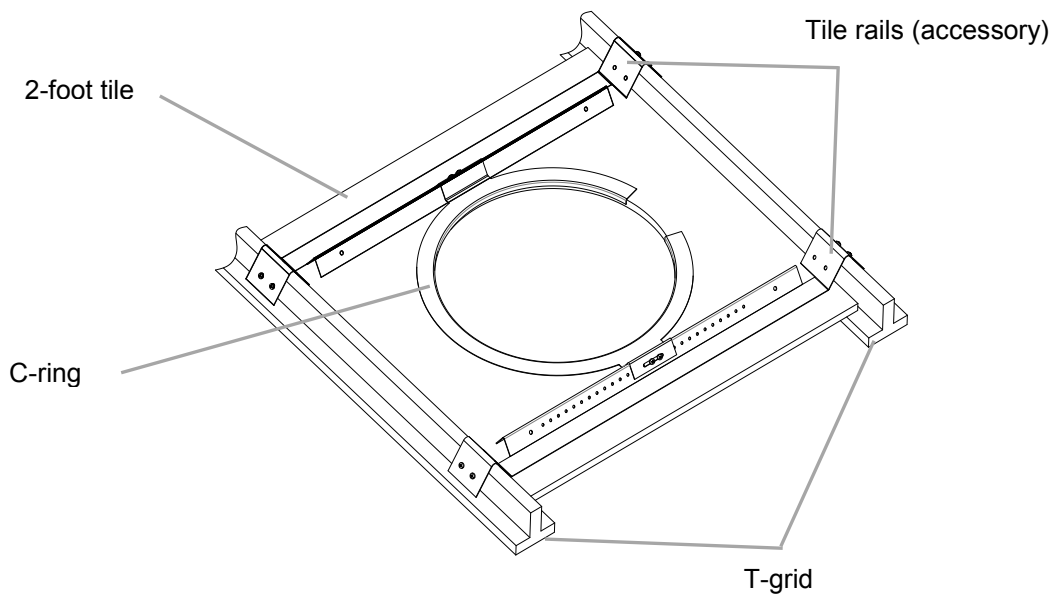

Step 3. Attach a safety wire from the speaker to the building structure to prevent accidental fall. Securely attach one end of the safety wire to the eye bolts located on the top of the speaker, and securely attach the other end to stable building structure.

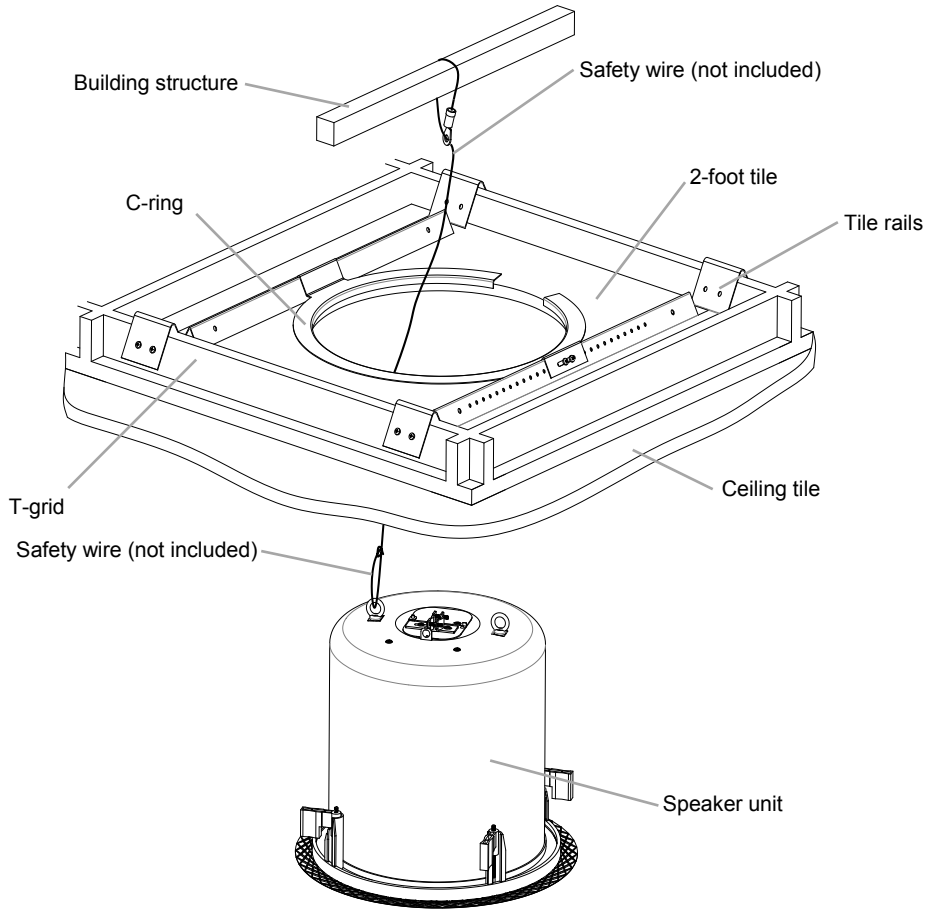

7. WIRING

Step 1. Loosen the screws on the choke bracket to allow the speaker cable to pass through.

Step 2. Loosen the screw on the connector cover plate and rotate the plate to open.

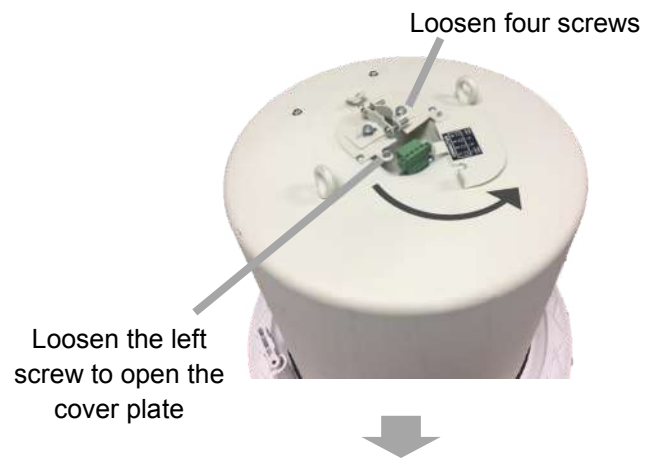

Step 3. Put the speaker cable through the choke bracket.

Step 4. Detach the removable terminal connector then wire speaker cable by referring to page 8.

Step 5. Plug the wired removable terminal connector back into the speaker's socket.

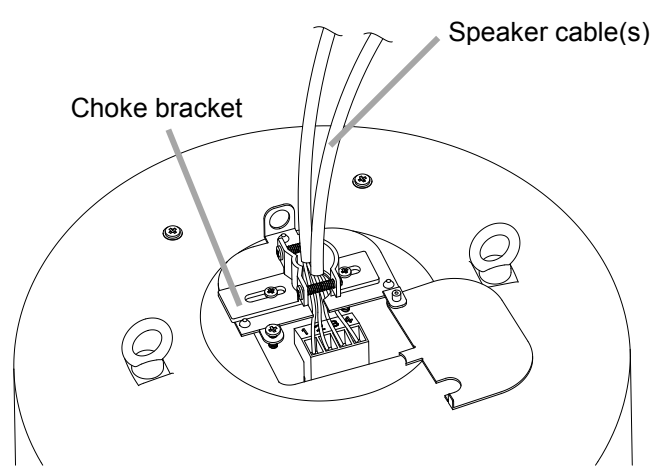

Step 6. Retighten the screws on the choke bracket to fix the speaker cable not to be pulled off.

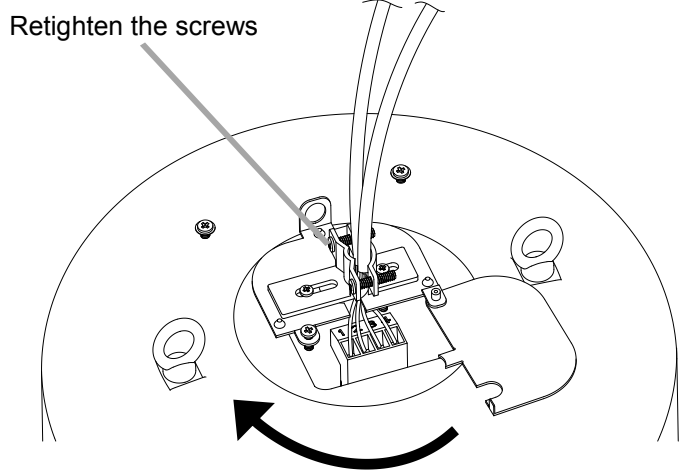

Step 7. Rotate the cover plate to close and fix it by retightening the screw.

8. CABLE CONNECTION TO TERMINAL CONNECTOR

Recommended cable types

- Solid copper wire: $\varnothing 1.0 - \varnothing 2.0$ mm (equivalent to AWG 18 – 12)
- Stranded copper wire: $0.8 - 3.3$ mm² (equivalent to AWG 18 – 12)

Step 1. Loosen the cover mounting screw, and rotate the Cover plate in the direction indicated by the arrow in the figure at right.

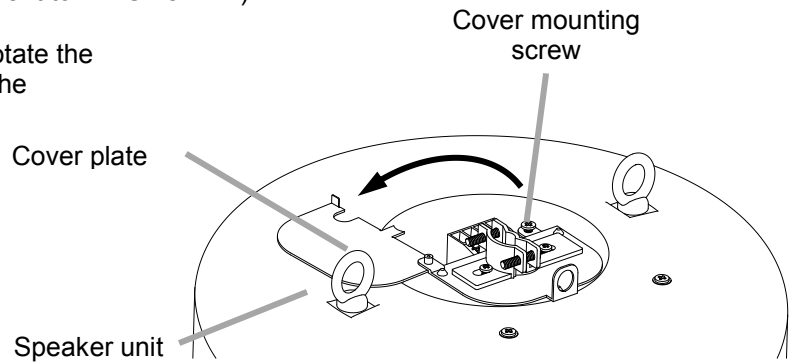

Step 2. Detach the removable terminal connector from the speaker's socket, and loosen the screws of the terminal to insert wires.

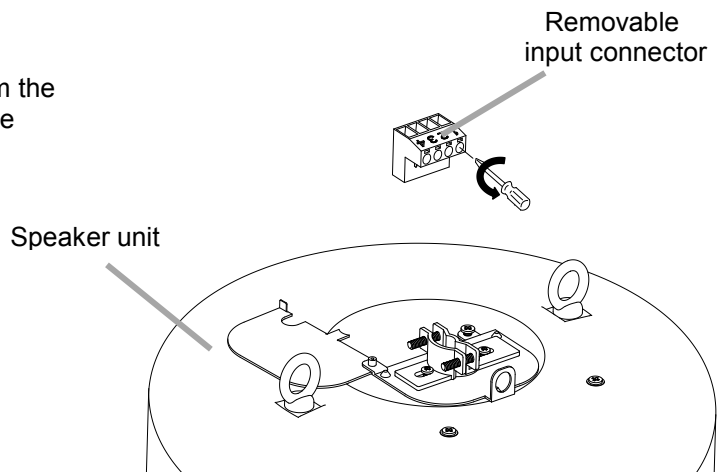

Step 3. Insert the stripped cable end into the terminal and tighten the terminal screws with a screwdriver.

[If not bridging]

[If bridging]

Note

If not making bridge connections, be sure to tighten unused terminal screws to avoid their vibration.

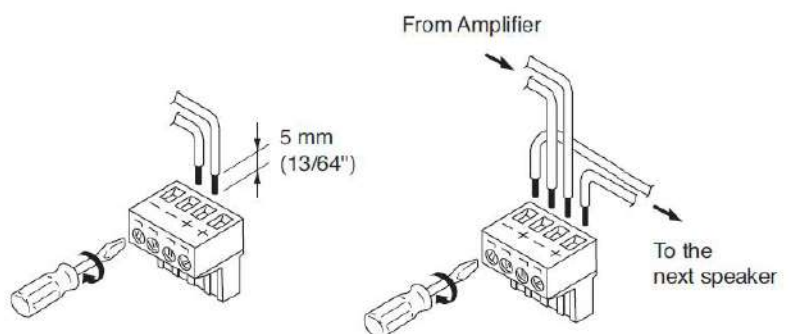

9. SPEAKER INSTALLATION

- Step 1.** Remove the front grille.
Turn the mounting tabs out and push them up towards the grille so that the grille comes off.

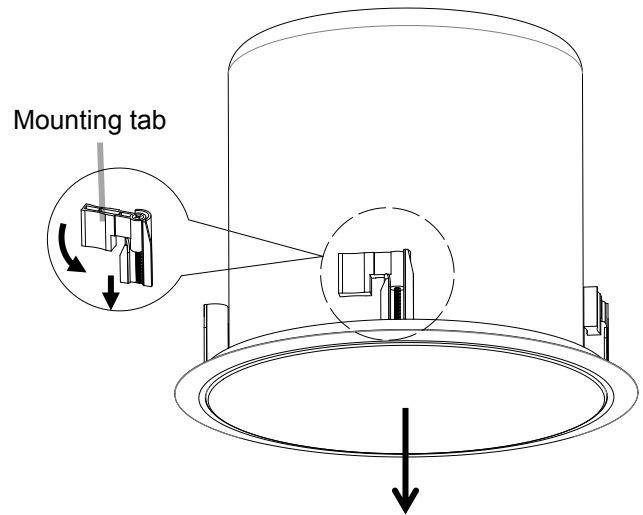

Caution

Before mounting, check to be sure that the speaker's 4 mounting tabs are turned inside the unit as shown in the figure. If turned outward, the speaker cannot be inserted through the mounting hole.

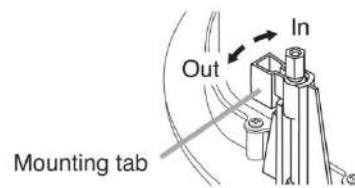

- Step 2.** Insert the speaker through the mounting hole till it contacts the ceiling panel.

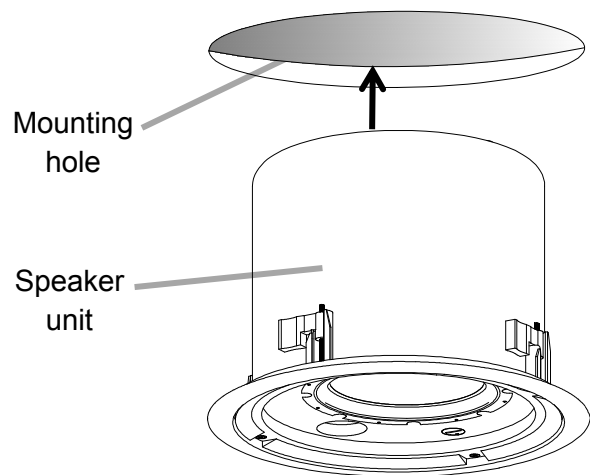

- Step 3.** Rotate and tighten the mounting tab axis screws (4 places) on the unit clockwise to their full stop in order to grip the ceiling panel with the mounting tabs.

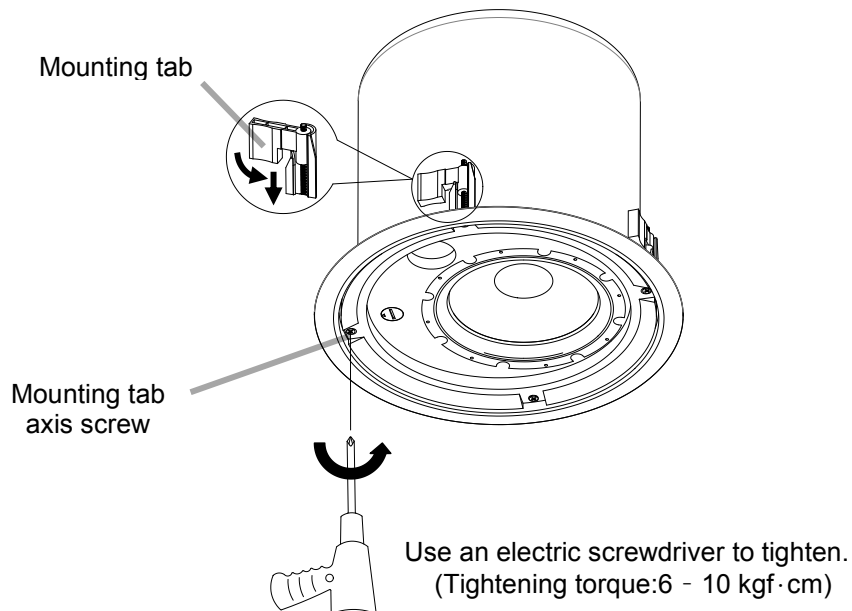

Step 4. Set the input power.

Adjust the loudspeaker tap using the 70V range until an acceptable balance between high/mid loudspeakers and the FB-3862CU-AM is achieved. (Factory-preset: 30W@70.7 Volt)

Note

Setting position "Low-Z" can be used in **UL1480A Category UEAY** and **CAN/CSA C22.2 No.205 Category UEAY7**.

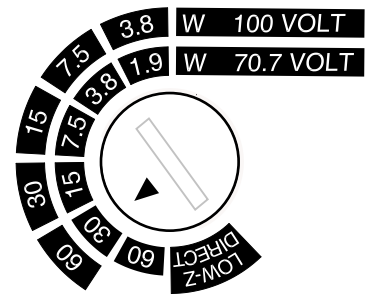

CAUTION

Do not use the Low-Z setting with an amplifier that is designed for use with a 70V system. Damage to the amplifier and/or speaker may occur. If you are installing the FB-3862CU-AM as part of a bi-amplified system (electronics crossover feeding high/mid and low frequency amplifier channels) with low impedance amplifiers (4Ω or 8Ω outputs), use the Low-Z direct setting. A high pass filter set at 40Hz and low pass filter set at 100Hz will help protect the FB-3862CU-AM from extreme low frequencies and provide an omnidirectional low frequency source.

Step 5. Attach the front grill.

Push the grille up with the edge slides into the slit of the speaker till it gets flat to the speaker frame.

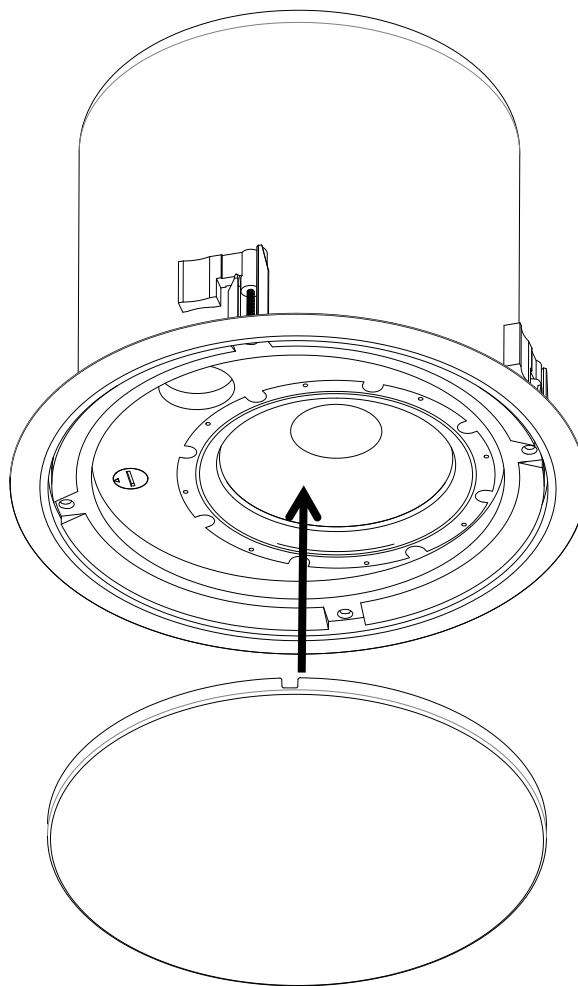

10. REMOVING THE SPEAKER FOR MAINTENANCE

Step 1. Remove the front grill

Find the small gap (see illustration) on the front grill, then use a small flat screwdriver to remove the front grill.

Caution
The width of the gap is less than 9mm.

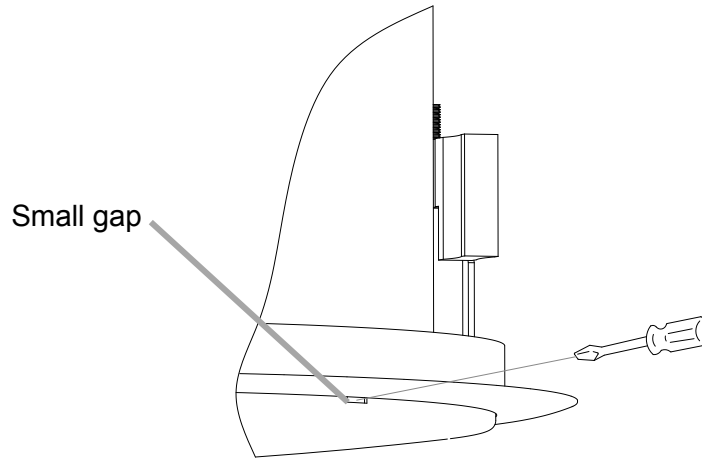

Step 2. Loosen the mounting tab

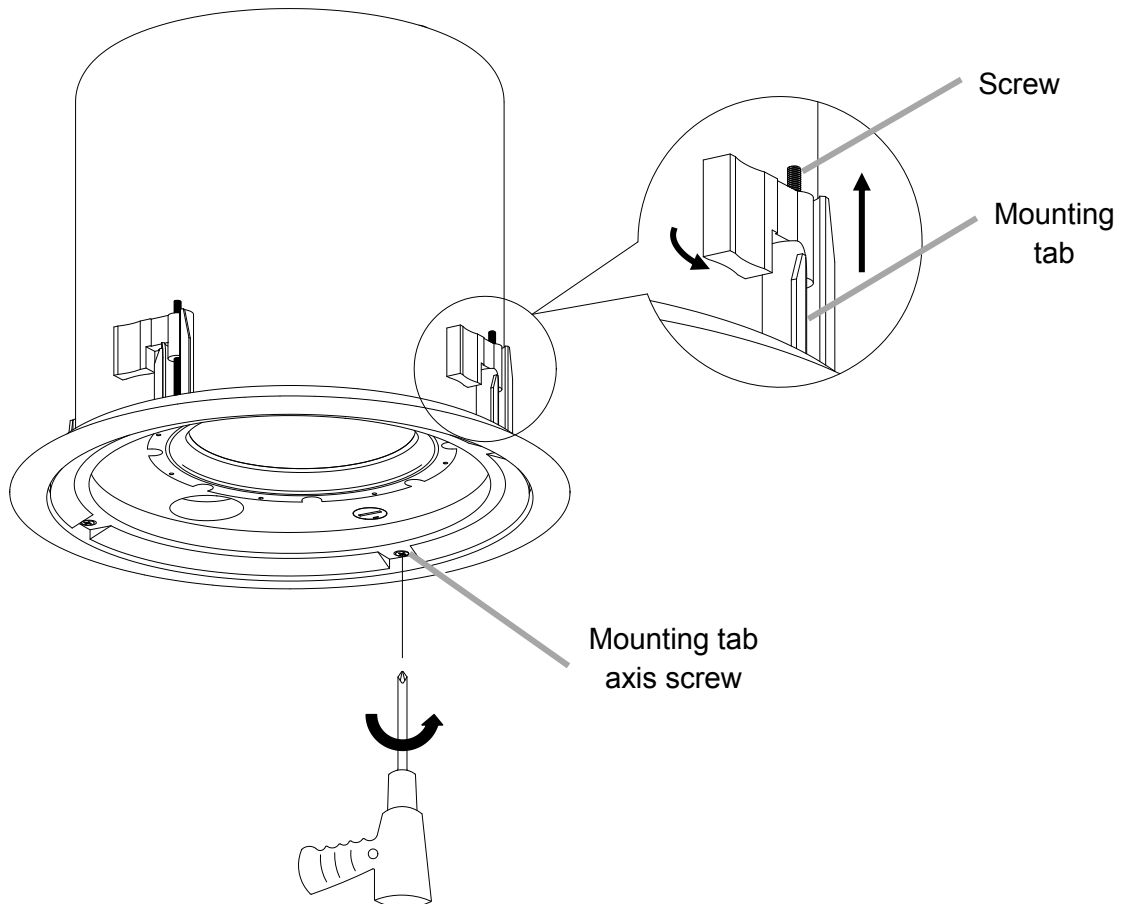

Use an electric screwdriver to detach.

Caution

Be sure to set the screwdriver's torque for under 4 kgf·cm. Failure to do so may cause the screw cap and the mounting tab to fall off on the rear of ceiling panel.

11. SPECIFICATIONS

Enclosure	Bandpass
Rated Input	60W (70/100V)
Power Handling Capacity	100W RMS 200W Peak (Low-impedance)
Impedance	70V line- 60W/30W/15W/7.5W/3.8W/1.9W with Low Impedance (8Ω) bypass
Sensitivity	91dB 1W/1m
Frequency Response	45-200 Hz (-10dB)
Speaker Component	8" driver with oiled paper cone and foam surround
Certifications	UL2043/UL1480A/CSA C22.2 No. 205, Baffle meets UL 94-V0, RoHS compliant.
Mounting Hole	350mm diameter(13.8")
Input Terminal	Phoenix-type with bridging outputs (max 12AWG stranded cable)
Recommended Cable	Max 12AWG stranded unshielded twisted pair (jacket per code)
Finish	White
Dimensions	383mm diameter x 326.5 mm height
Weight	6.71 kg (14.79 lb)
Included Accessories	Steel support ring (C-ring), qty 1 steel support rails, qty 2 speaker hole template, qty 1 operation manual,qty 1
Optional Accessories	Support and safety cables (load rated chain or load rated aircraft cable)

Note: The design and specifications are subject to change without notice for improvement