

HX-5W

SPEAKER SYSTEM



The HX-5W is a 2-way compact speaker system that permits both constant directivity control over a wide frequency range and changes in directivity. It is ideal for reproducing clear sound in spaces with long reverberation times or high background noises. The HX-5W is designed for indoor use.

Key features

- Power handling: 600W Continuous Program@8 ohms
- One module is composed of 1 x 4.72" cone-type LF driver and 3 x 1" balanced dome tweeters
- Adjustable dispersion angle 15°, 30°, 45° and 60°
- Maximum four speaker units can be stacked

Specifications

Enclosure	Bass-reflex type
Power Consumption	Continuous pink noise: 200 W, Continuous program: 600 W
Impedance	8 Ω
Sensitivity	96 dB (60° mode), 97 dB (45° mode), 98 dB (30° mode), 99 dB (15° mode)
Frequency Response	70 Hz - 20 kHz (-10 dB) (60° mode), 75 Hz - 20 kHz (-10 dB) (45° mode), 80 Hz - 20 kHz (-10 dB) (30° mode), 85 Hz - 20 kHz (-10 dB) (15° mode)
Crossover Frequency	4 kHz
Directivity Angle	Horizontal: 100° (over 2,000 Hz) Vertical: 60° (over 800 Hz), 45° (over 1.2 kHz), 30° (over 1.6 kHz), 15° (over 3.2 kHz) variable
Speaker Component	Low frequency: 12 cm cone-type x 4, High frequency: Balanced dome-type x 12
Input Terminal	Speakon NL4MPXX x 2 and M4 screw terminal
Finish	Enclosure: Polypropylene, white Punched net: Surface-treated steel plate, white
Dimensions	408 (W) x 546 (H) x 342 (D) mm
Weight	16 kg
Included Accessories	Hanging bracket x 2, Hex. wrench x 1
Optional Accessories	Matching transformer : MT-200 Speaker mounting bracket: HY-PF1W, HY-CW1W, HY-WM1W, HY-WM2W, HY-CN1W Speaker stand adapter: HY-ST1

Dimensions

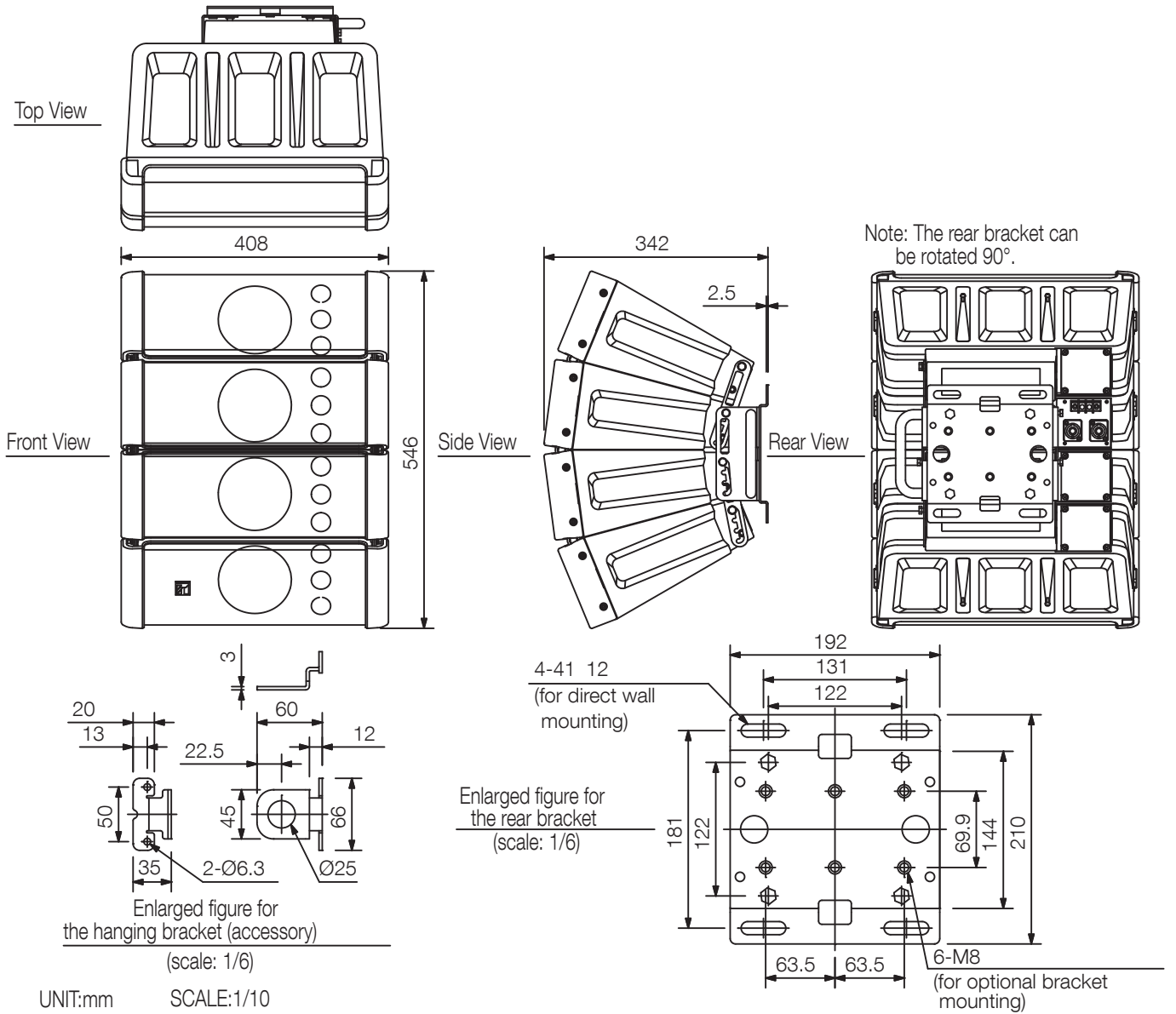

Dimensions

Example for directivity angle modes

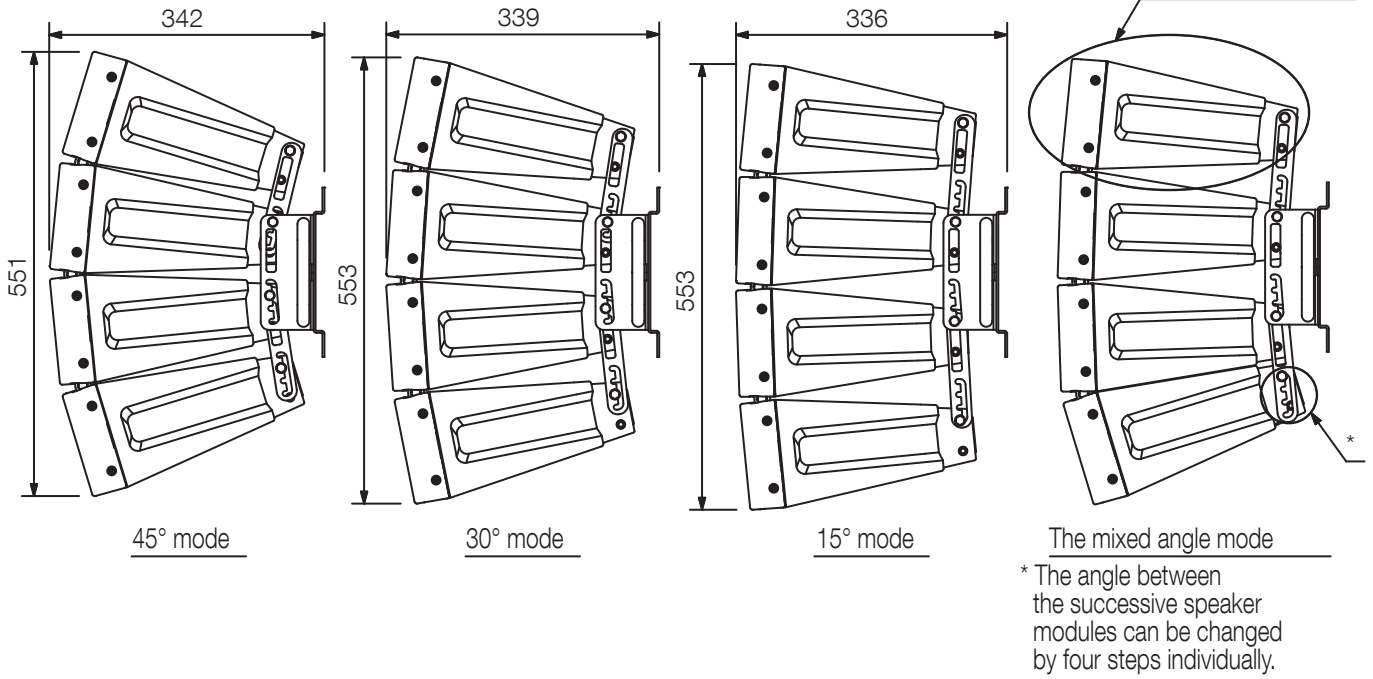

Example for hanging bracket mounting

(scale: 1/15)

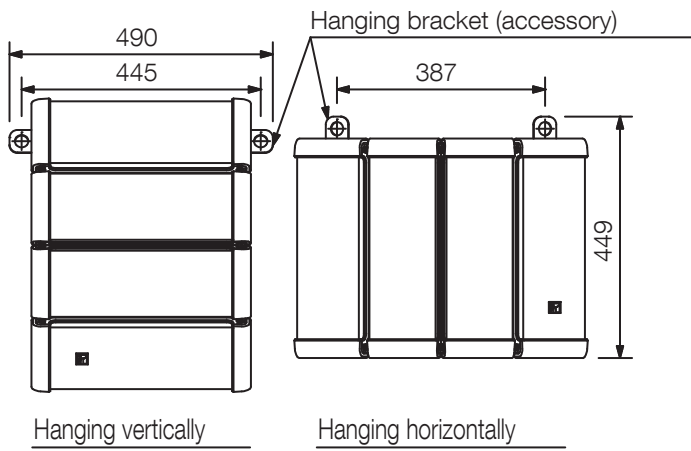

Dimensions

Example for direct wall mounting

(scale: 1/15)

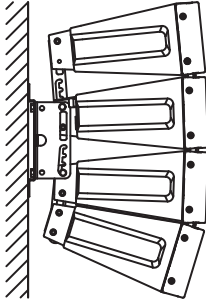

Dimensions for direct wall mounting

(scale: 1/15)

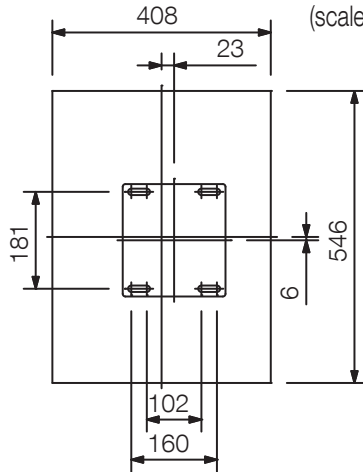

When the speaker is set vertically
(60° mode)

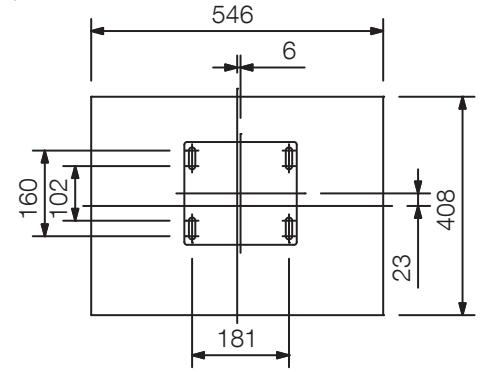

When the speaker is set horizontally
(60° mode)

UNIT:mm

SCALE:1/10

A&E specifications

The speaker shall be a modular, compact, direct-radiating two-way design with integral mounting bracket. The low-frequency section shall consist of four direct-radiating 4.72" (12 cm) cone-type drivers arranged in a vertical line, with each driver housed in a separate tuned and ported enclosure module. The high frequency section shall consist of twelve direct-radiating 1" (25 mm) balanced-dome tweeters arranged in a vertical line, mounted adjacent to the low frequency drivers, with 3 tweeters per enclosure module. The speaker shall incorporate line array design elements to achieve highly controlled directivity in the vertical plane, and a contoured waveguide-baffle design for controlled directivity in the horizontal plane. Speaker construction shall be modular and shall allow on-site adjustment of directivity in the vertical plane over a range from 15 degrees to 60 degrees nominal coverage angle, in 15 degree increments. Horizontal coverage shall be 100 degrees nominal, irrespective of the adjustment of the vertical angle. The integral mounting bracket shall be made of 12 gauge steel and shall allow for a 90 degree rotation of the speaker orientation. The integral frequency dividing network shall include both low pass and high pass filter sections and shall be optimized for smooth on-and off-axis frequency response in all directional configurations. The crossover frequency shall be 4 kHz. The speaker input connectors shall include one screw terminal connection and two Neutrik NL4 type sockets, wired in parallel for pass-through to additional speakers.

The speaker shall meet the following performance criteria. Power handling: 200 watts continuous pink noise, 600 watts continuous program. Frequency response (10 dB below rated pressure sensitivity, without external equalization): 70 Hz to 20 kHz in 60 degree mode, 75 Hz to 20 kHz in 45 degree mode, 80 Hz to 20 kHz in 30 degree mode, 85 Hz to 20 kHz in 15 degree mode. Pressure sensitivity (1 watt at 1 m): 96 dB in 60 degree mode, 97 dB in 45 degree mode, 98 dB in 30 degree mode, 99 dB in 15 degree mode. Impedance: 8 ohms nominal. When the optional line matching transformer model MT-200 is installed, the available power taps for 70.7 volt line applications shall be 30, 60, 100 and 200 watts (167, 83, 50, and 25 ohms respectively).

The speaker's design approach shall be such that two or more may be combined in a linear array to increase output and/or coverage with no degradation of the consistency of the coverage pattern. When two are combined, the available vertical coverage angles (-6 dB cutoff) shall be 30 degrees (+ 12/- 5 degrees from 500 Hz to 16 kHz), 60 degrees (+/- 15 degrees from 400 to 12.5 kHz), 90 degrees (+10/-20 degrees from 250 Hz to 20 kHz), and 110 degrees (+/- 20 degrees from 200 Hz to 20 kHz). Horizontal coverage shall remain 100 degrees nominal. Available accessory brackets shall allow for both the co-joining of multiple units in a linear array and the suspension of the array in vertical or horizontal orientation.

The modular enclosure shall be made of polypropylene, with steel brackets and hardware. The dimensions (W x H x D) shall be 16.1" x 21.5" x 13.5" (408 mm x 546 mm x 342 mm) and weight shall be 35.3 lbs. (16 kg). Suspension brackets shall be supplied with the speaker to allow suspension in either vertical or horizontal orientation. Available accessory brackets for wall, ceiling and stand mounting shall be made of steel.

The loudspeaker shall be TOA model HX-5B / HX-5W.

The subwoofer shall be TOA model FB-120B / FB-120W.

The indoor connection bracket shall be TOA model HY-CN1B / HY-CN1W.

The ceiling mount bracket shall be TOA model HY-CW1B / HY-CW1W.

The pre-install rigging frame shall be TOA model HY-PF1B / HY-PF1W.

The stand adapter shall be TOA model HY-ST1.

The wall/ceiling mounting bracket shall be TOA model HY-WM1B / HY-WM1W.

The wall/ceiling direct mounting bracket shall be TOA model HY-WM2B / HY-WM2W.

The matching transformer shall be TOA model MT-200.