

MA/E9/S2/T8

SOUND MASKING

617 CID Grid Mount, Composite Back Box Assembly,
4W-70V rotary select transformer



GENERAL DESCRIPTION

The MA/E9/S2/T8 is an 617 CID, ceiling grid mount, sound masking loudspeaker assembly consisting of an 8C10PAX - 8" O.D. dual cone loudspeaker with a 10 oz. magnet and a TBL70 - 4W-70V rotary select transformer. Support chain is supplied.

INTENDED USE - Indoor Environment

Installation	Placed upward-facing on 24" wide ceiling tile on conventional suspended ceiling grid
Primary Use	Equalized random noise
Secondary Use	Signal tones or equalized voice



AUDIO SPECIFICATIONS

Average Sensitivity	95 dB-SPL 1W/1M
Loudspeaker Power Rating	20W RMS, EIA 426A Standard
Calculated Output	101 dB SPL, 5W/ 1M
Magnet Type, Weight	BeFe Ceramic, 10 oz
Frequency Response	65 Hz - 17 kHz EIA 426A Standard
Nominal Coverage Angle	100° Included Angle, -6 dB / 2 kHz, Half space
Audio Connection	Pre-cut 7" color coded leads
Mechanical Connection	Seismic tie-offs provided on top of unit if required by AHJ

SYSTEM COMPONENTS

Loudspeaker	8C10PAX
Transformer	70V 4W-5 tap Color Coded Leads (4W, 2W, 1W, 0.5W, 0.25W)

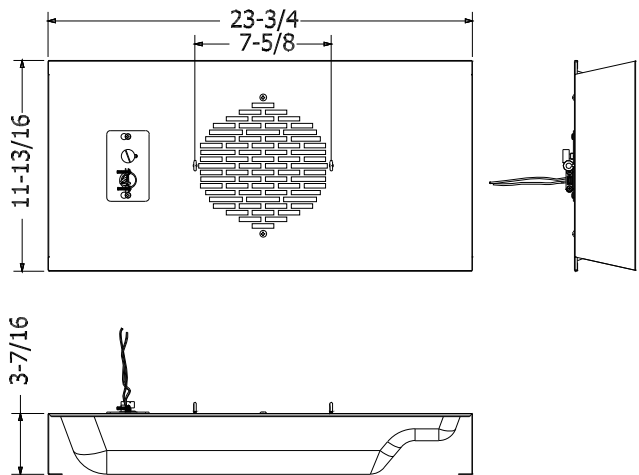

Recommended construction sequences, installation instructions, and A&E Specifications are available in various formats in the QUAM Architects' and Engineers' Resources section on the web at:
www.QuamSpeakers.com

© 2013 Quam-Nichols Company reserves the right to make changes and/or improvements to its products at any time and without notice.



QUAM-NICHOLS COMPANY, INC.
234 East Marquette Rd.
Chicago, IL. 60637
Tel: 1-800-NEED-NOW (800-633-3669)
Fax: 1-888-NEED-NOW (888-633-3669)
e-mail: NeedNow@QNC.com
www.QuamSpeakers.com