



MV88plus Video

MV88+ Video Kit

The ShurePlus MV88 video app user guide.
Version: 4 (2020-D)

Table of Contents

MV88plus VideoMV88+ Video Kit	3	Equalizer	15
General Description	3	Recording Tips	15
Features	3	Turn Off Notifications	15
Standby Mode	3	Adjust your Sample Rate	15
Visual Settings	4	Get the Best-looking Video Image	16
Record Mode	5	Record in Mono	16
Using the ShurePlus MOTIV™ App with the MV88+ microphone	5	Record in Stereo	16
Aiming the Microphone	5	Capture the Complete Performance	16
MV88+ Outputs	10	Record with Confidence with Automatic Save	16
Mic Setup	11	Sharing MOTIV Recordings	16
Preset Modes	13	Troubleshooting	16
Monitor Mix Blend	14	System Requirements	17
Advanced Mic Settings	14	System Requirements and Compatibility: iOS	17
Limiter	14	System Requirements and Compatibility: Android	18
Compressor	14	Specifications	18
High Pass Filter	14	Bit DepthSampling Rate2448 kHz2444.1 kHz1648 kHz1644.1 kHz	19
Left-Right Channel Swap	15	Supported Audio Formats	19
		Certifications	19

MV88plus Video MV88+ Video Kit

General Description

The Shure® MV88+ Video recording app provides instant video recording with uncompressed audio for your mobile device. Customize the sound with digital signal processing (DSP) preset modes, adjustable gain, and stereo width control.

Features

- Compatible with iOS, Android, PC and Mac devices.

Note: See <https://www.shure.com/MOTIVcompatibility> for information on recommended Android devices.

- Plug-and-Play Operation supporting landscape and portrait recording
- Flexible Recording Control includes gain adjustment settings
- Support for mono and stereo audio devices
- When used with MOTIV microphones, preset modes are available for a variety of recording situations.

Tip: Turn on Airplane Mode and Do Not Disturb to prevent interruptions to the recording caused by phone calls, text messages, or alerts.

Standby Mode

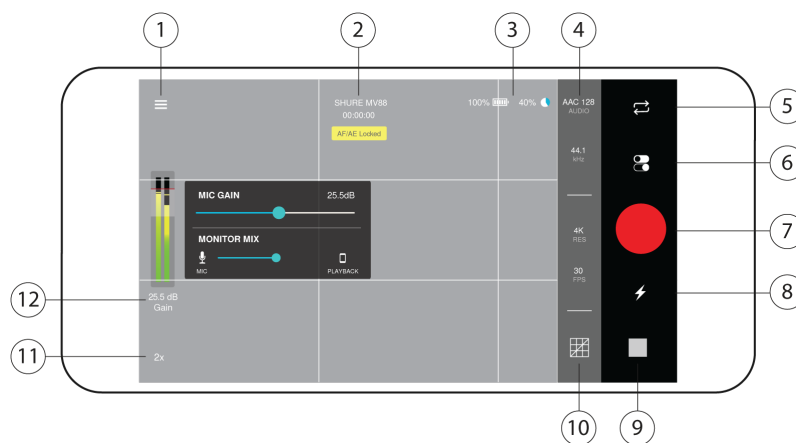

① **Menu** Tap the menu to access general app settings or to open the about window for version information, help materials, and to send feedback.

② **Connected Device Status/Recording Length/Focus Lock** Status will display the model name of the connected MOTIV device. Recording length is displayed in hours, minutes, and seconds. See the Visual Settings topic for more information on focus and exposure.

③ **Device Status** Displays remaining battery life and available storage space for your recording device.

④ **File Information** Displays video format options

Note: Option availability may vary based on your mobile device specifications.

- **Audio file formats:** (iOS) WAV, AAC 96, AAC 128, AAC 256 (Android) AAC 96, AAC 128, AAC 256
- **Sample rate:** 44.1 kHz, 48 kHz
- **Video resolution:** 720p, 1080p, 4K
- **Frame rate:** 24 fps, 30 fps, 60 fps

⑤ **Reverse Camera** Use the front-facing camera to shoot selfie videos.

⑥ **Mic Setup** Access advanced microphone settings. See Mic Setup section for more information.

⑦ **Record/Stop Button**

⑧ **Flash** Use the flash when recording in low light situations.

⑨ **Preview Window** Tap to review the most recently recorded video.

⑩ **Grid/Level/Off Display** Tap through to display grid lines or a level for easy image composition. Or turn this feature off if you prefer a clean display.

⑪ **Zoom Level** Adjust your zoom level for a closer view of your subject.

⑫ **Input Meter/Microphone Gain** Tap the input meter to bring up the mic gain slider. Tap to adjust microphone gain during recording to match the volume of the sound source. Make live adjustments to ensure levels are in the target range (indicated by the shaded region of the input meter). Displays the strength of the mono or stereo input signal.

Note: Display will read AGC when using the app with the built-in microphone. Automatic Gain Control (AGC) adjusts levels to ensure consistent volume. Weaker signals are boosted and stronger signals are attenuated to control gain. The dynamic range is decreased but the result is a more even recording.

Visual Settings

Set your visual settings to get the best-looking video image.

Zoom: Pinch to zoom in or out and frame your shot.

Brightness: Swipe up and down to set brightness level.



Focus: Tap to focus or tap and hold to lock brightness and focus. Tap again to release the lock.



Record Mode

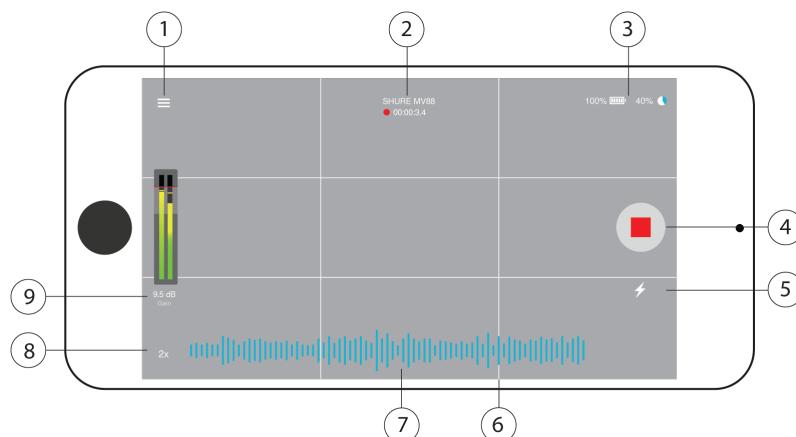

① **Menu** Select the menu to access general app settings and the About window for version information.

② **Connected Device Status/Recording Length/Focus Lock** Status will display the model name of the connected MOTIV device. Recording length is displayed in hours, minutes, and seconds. See the Visual Settings topic for more information on focus and exposure.

③ **Device Status** Displays remaining battery life and available storage space for your recording device.

④ **Record/Stop Button** Start and stop video recording.

Note: Stopping the recording creates a video file that is saved in the Photos folder on your mobile device.

⑤ **Flash** Use the flash when recording in low light situations.

⑥ **Grid** Use the grid lines to assist in composing your image.

⑦ **Audio Recording** The MOTIV Video App displays the waveform of the audio as it is recording.

⑧ **Zoom Level** Adjust your zoom level for a closer view of your subject.

⑨ **Input Meter** Displays the strength of the mono or stereo input signal. Tap to adjust microphone gain during recording. The loudest peaks should reach within the target range (indicated by the shaded region of the input meter).

Note: The maximum file size for a recording is 2GB, which will result in approximately 2 hours of record time. This limitation was put in place to maximize app performance. Continuous recording for more than 2 hours will generate a second file.

Using the ShurePlus MOTIV™ App with the MV88+ microphone

The MOTIV app controls microphone settings to optimize performance for specific uses. The device stores the most recently used settings for quick setup each time you record.

Aiming the Microphone

The following suggestions are for typical use cases. Keep in mind that there are many effective ways to record a source. Experiment with horizontal or landscape orientation, microphone placement and settings to find what works best for you.

Portrait (Vertical)

Position your recording device so you can monitor the recording. Aim the front of the microphone toward the source, with left and right sides facing the appropriate directions.

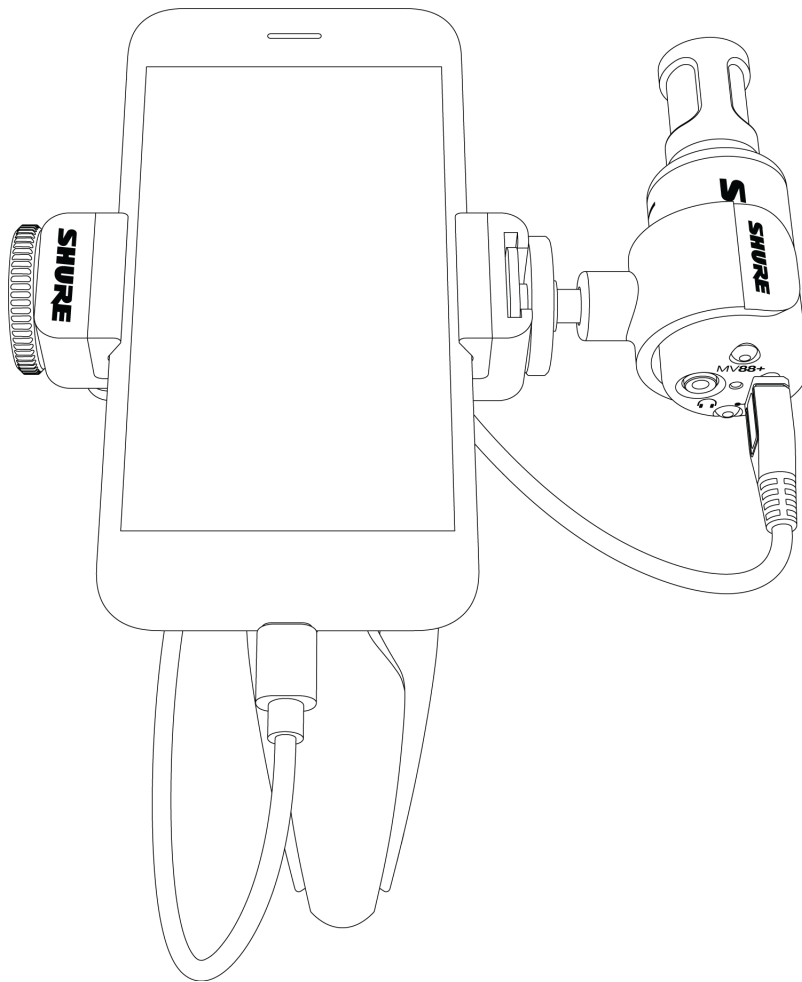

Landscape (Horizontal) Video Recording

Aim the front of the microphone toward the source. Ensure that the left and right sides of the microphone barrel are facing the appropriate sides.

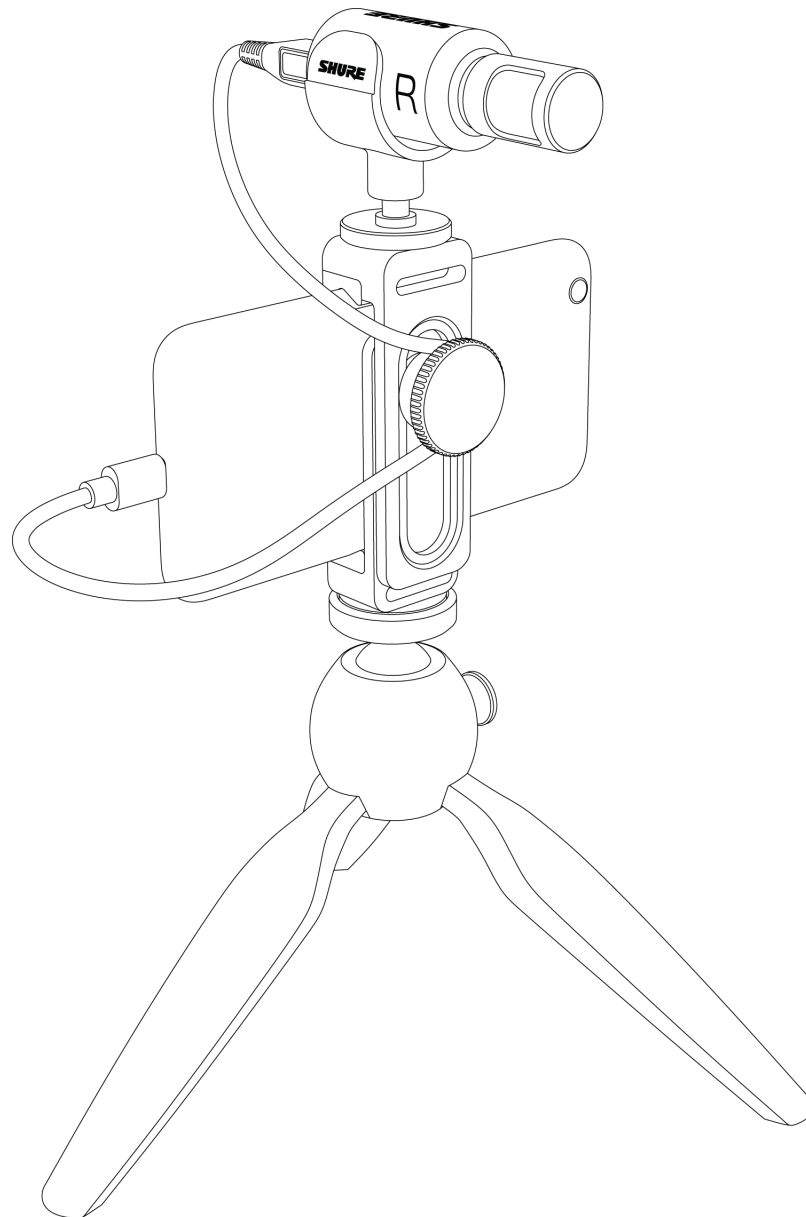

Portrait/Selfie (Vertical) Video Recording

Aim the microphone toward yourself and select Left - Right Swap.

Tip: If you begin shooting in portrait mode, video will remain in portrait mode even if device orientation is turned to landscape.

Video Interview

- To record audio from on-camera audio only, select the CARDIOID polar pattern and point the microphone toward your subject.

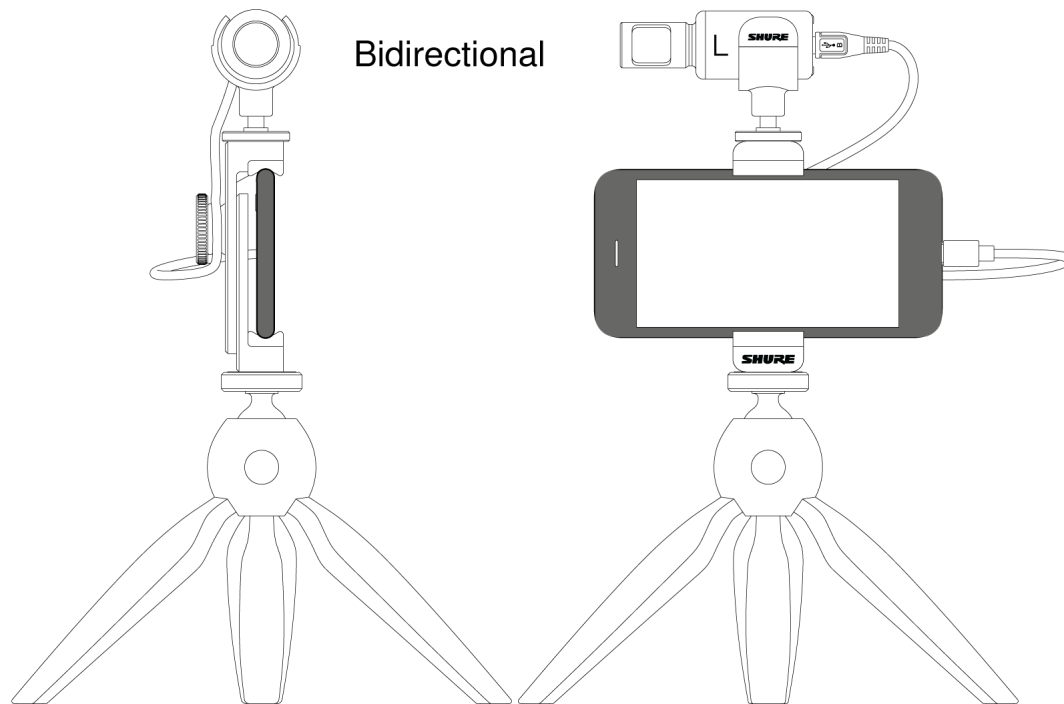

- To capture the voices of both the on-camera subject and the off-camera interviewer, select the MONO BIDIRECTIONAL polar pattern in the app. Position the microphone with the left and right sides facing each person.

Self-Recording (Video Streaming)

Set the device on a flat surface and angle the microphone toward your mouth. Select the MONO CARDIOID preset in the MOTIV app to reduce ambient noise.

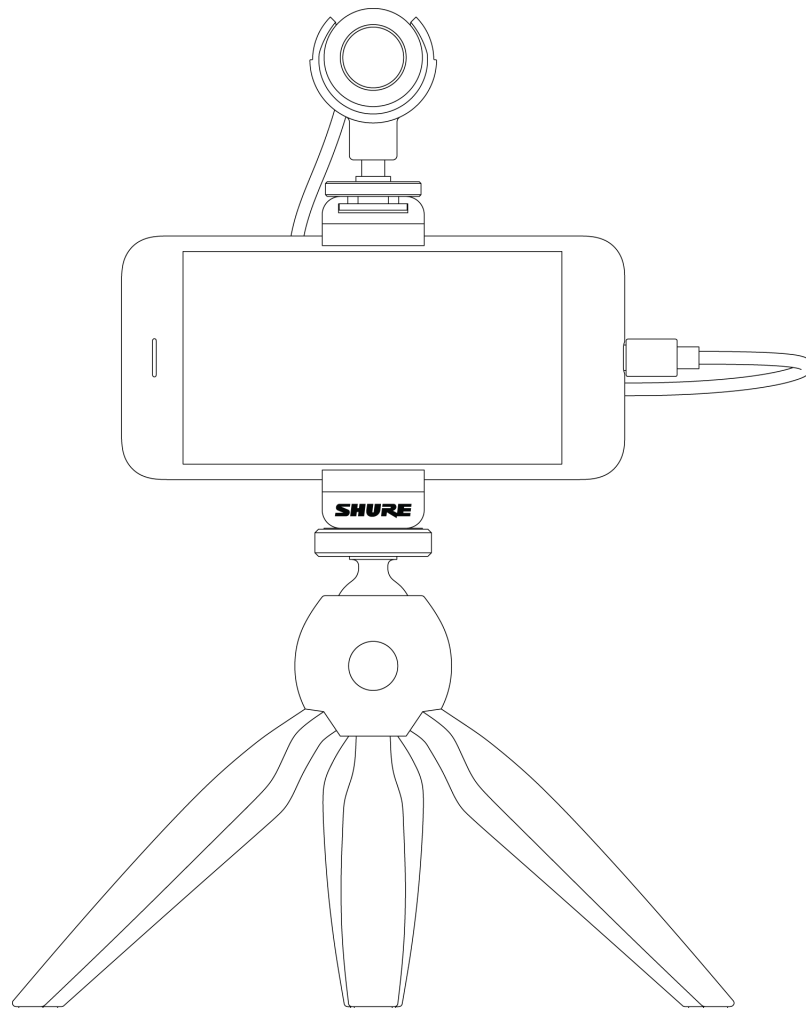

Handheld Recording

The legs collapse to create a portable hand-held stand.

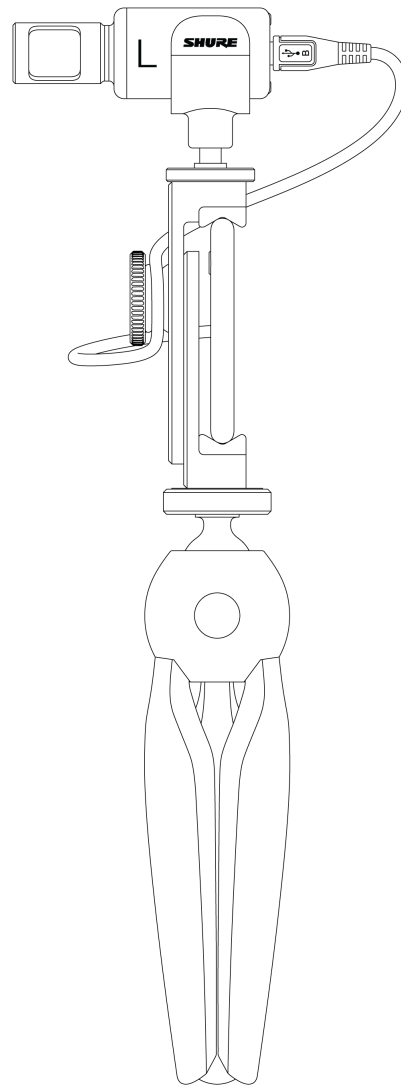

MV88+ Outputs

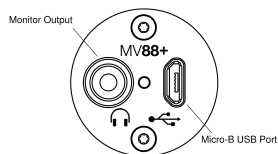

- 3.5mm monitor output for connecting to headphones and earphones
- Send audio to your recording device using the micro-B USB port

MV88+ LEDs

iOS	Android/Mac/PC
Green: Mic active, audio flowing	Green: Power is on
Amber: Error	

iOS	Android/Mac/PC
Flash Amber: Firmware is updating	
Red: Microphone is muted	
Flash Red: Audio is clipping	



Mic Setup

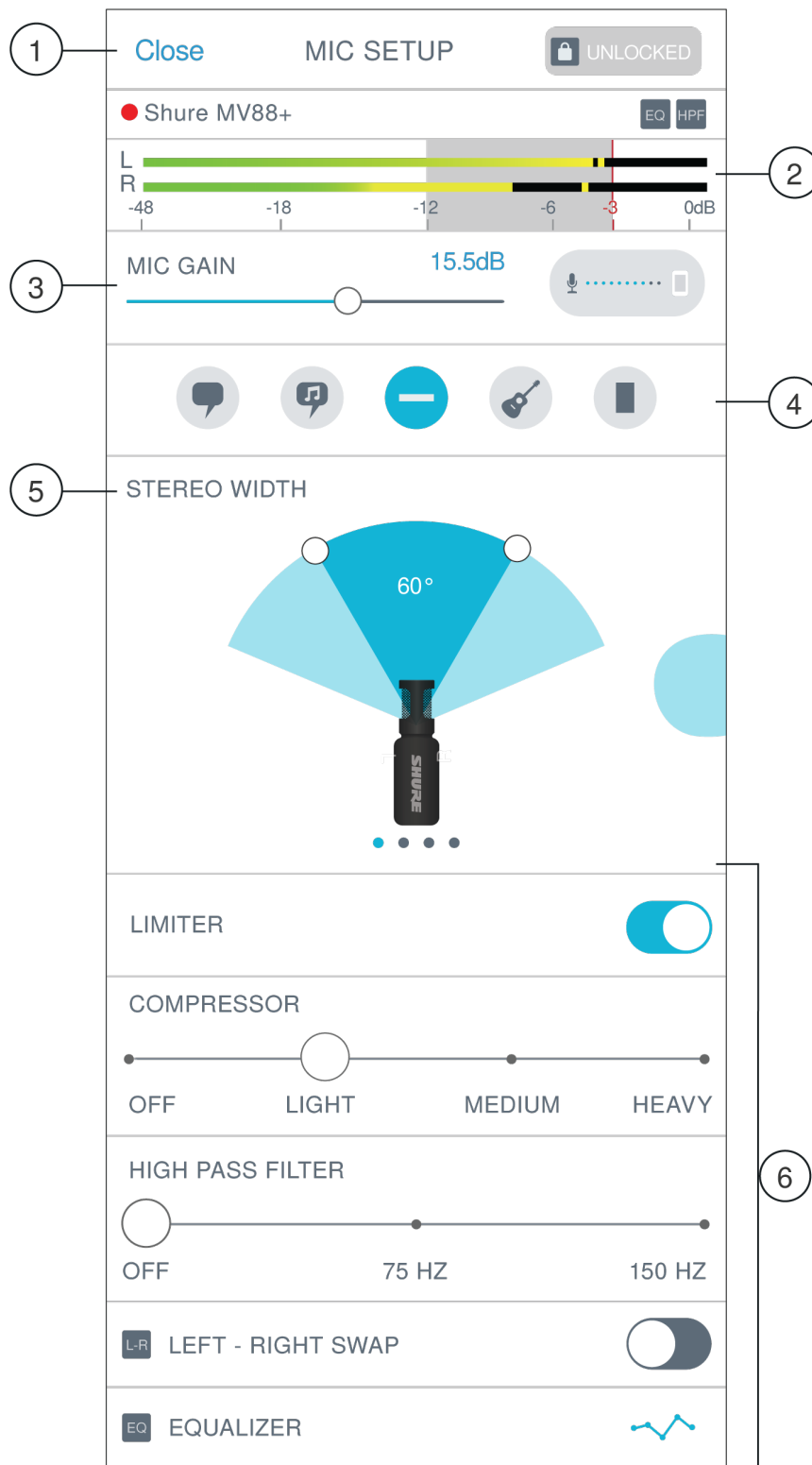

① **Header** Tap Close to return to the record window. Toggle between Locked and Unlocked options to prevent accidental bumps or finger taps from changing your sound and to lock in your mic gain, presets and advanced settings. When mic settings

are Locked, the setting screen is grayed out. The line above the input meter displays the connected microphone and indicates which effects are in use and recording status.

② **Input Meter** Displays the strength of the input signal and whether that signal is mono or stereo. The loudest peaks should reach within the target range (indicated by the shaded region).

③ **Microphone Gain/Monitor Mix** Adjust the mic gain slider to match the volume of the sound source. Levels are in the target range when they peak in the shaded region of the input meter. Tap the oval button to access monitor mix settings. See the monitor mix section for information on making monitoring adjustments.

④ **Preset Modes** Select a mode to set stereo width, equalization, and compression for specific applications. Refer to the "Preset Modes" topic for more details.

⑤ **Polar Pattern Selection** Swipe to choose between Stereo, Mono Cardioid, Mono Bidirectional or Raw Mid-Side pick-up patterns. Then adjust the width of the stereo microphone pickup area.





Tip: Consider the location of the microphone and the size of the sound source when adjusting the width. For example, a large orchestra or ensemble recording will benefit from a wide stereo image to achieve increased separation between instruments. Other applications, such as speech, benefit from a narrow width for improved clarity with rejection of ambient (room) sound.

⑥ **Advanced Features** Fine tune your audio recording with limiter and compressor controls, high pass filter, left-right swap, and equalization settings. Your settings will be retained in the microphone. See "Wind Noise Reduction" and "Left-Right Channel Swap" for more details on these topics.

- **Limiter:** Use the Limiter to control volume peaks by setting an input threshold.
- **Compressor:** Use the Compressor when your sound source is very dynamic. The compressor will narrow the dynamic range; quiet signals are boosted and loud signals are lowered. There are light and heavy compression options available.
- **Equalizer:** Use the Equalizer to boost or cut bands of frequencies to improve sound clarity. The EQ icon in the Mic Setup screen displays user-selected equalization.

Preset Modes

Five selectable modes optimize settings for gain, stereo width, equalization, and compression. Set the microphone level and try the modes to find which sounds best. Preset modes can affect the strength of the input signal, so adjust the microphone level as needed after changing presets.

Mode	Application	Characteristics
 Speech	speech	Narrow stereo width to reject background noise, equalization that emphasizes clarity and fullness, and gentle compression.
 Singing	solo or group vocal performances	Medium stereo width with subtle equalization to add richness and clarity for a natural sound.
 Flat	any	An unprocessed signal (no equalization or compression settings used). Adds flexibility when processing the audio after recording.
 Acoustic	acoustic instruments and quiet music	Medium stereo width with transparent compression to smooth out volume spikes and bring out quiet passages. The equalizer setting emphasizes detail and an overall natural sound.
 Loud	live performance and louder sources	Wide stereo to increase separation between sources. Equalization further improves definition by reducing frequencies that can make the instrumentation sound crowded.

Monitor Mix Blend

Tap the Monitor Mix button to view monitoring controls.

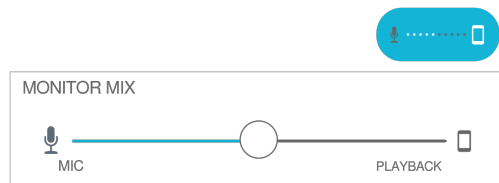

Use the monitor mix slider to determine how much of each input you hear. For best results, start monitoring at the midpoint and adjust.

- Move the slider towards the microphone icon (MIC) to hear more of the currently recorded audio.
- Move the slider towards the device icon (PLAYBACK) to hear more of the previously recorded audio.

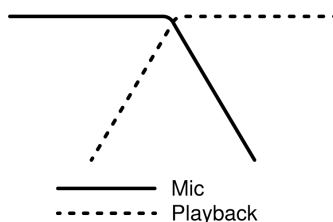

Advanced Mic Settings

After selecting the preset mode, fine-tune your sound with limiter, compressor, and equalizer settings. These settings are retained in the microphone when using other audio and video recording applications.

Limiter

Toggle the limiter on or off to prevent distortion from volume peaks in your recording.

Compressor

Choose no compression, or select light or heavy compression to control volume when your sound source is dynamic. Quiet signals are boosted and loud signals are lowered.

High Pass Filter



Choose no HPF for the most natural sound. Or select 75 Hz or 150 Hz to reduce wind noise, room noise, or proximity effect.

75 Hz Low frequency cutoff Provides a 6 dB-per-octave cutoff at 75 Hz. Helps eliminate floor rumble and low-frequency room noise from heating and air conditioning systems. This setting may also be used to compensate for proximity effect or to reduce low frequencies that make an instrument sound dull or muddy.

150 Hz Low frequency rolloff Provides a 6 dB-per-octave rolloff filter at 150 Hz. Use this to compensate for proximity effect or to reduce low frequencies that could make an instrument sound dull or muddy.

Left-Right Channel Swap



For stereo recordings, use Left - Right Swap to flip the left and right audio channels to match the stereo image to the video. For example, when using video to record yourself.

Tip: Use the L and R indicators on the microphone barrel. This way you can set Left - Right Swap before you start to record.

Equalizer



Change the preset modes to hear the DSP changes, and use the equalizer to boost or cut bands of frequencies to improve sound clarity.

Note: Equalization within presets will not be displayed. However, the EQ icon in the advanced settings status bar indicates user-selected equalization.



Equalization changes are displayed in the equalizer image.

EQ persists between preset mode changes.

Recording Tips

Turn Off Notifications

When you open the MOTIV app, a message prompts you to enable airplane mode and do not disturb mode. It's important to do this to avoid recording interference from phone calls, messages, and various notifications which can add static to your recordings.

Note: Enable airplane mode and then turn Wi-Fi back on to add geolocation information to your audio file.

Adjust your Sample Rate

Select a lower sample rate when it is useful to have a smaller file, for example, when recording speech or a podcast for download. Select a higher sample rate for music and dynamic recordings.

Get the Best-looking Video Image

Pinch to zoom in or out and frame your shot. Swipe up and down to set brightness. Tap to focus or tap and hold to lock brightness and focus. Tap again to release the lock.

Record in Mono

Record in mono to increase your available record time or when recording a single source, like vocals, that would benefit from less ambient noise. Select the Mono Cardioid or Mono Bidirectional polar pattern and audio from all capsules are summed to a single channel. The input meter will indicate mono recording by displaying the top half of the waveform. MOTIV supports third-party microphones with mono recording.

Record in Stereo

Rotate the MV88+ barrel in the mic clip to accommodate portrait or landscape recording. L and R are labeled to show stereo orientation of the microphone. The stereo image is accurate if the Shure logo is facing upward.

Capture the Complete Performance

To ensure that you capture the entire sound source, start your recording before the performance starts and edit the recording later to trim any silence.

Note: If your microphone accidentally becomes disconnected during recording, MOTIV will automatically stop the recording. The save file dialog will appear, prompting you to name and save your audio.

Record with Confidence with Automatic Save

If your microphone accidentally becomes disconnected during recording, MOTIV will automatically stop the recording. The save file dialog will appear, prompting you to name and save your audio.

Sharing MOTIV Recordings

Stop the recording to create a video file that is saved in the Photos app on your mobile device. You can share videos created with the MOTIV Video recording app from Photos.

- On an iOS device, find your video in Photos > MOTIV or in Photos > Media Types > Videos
- On an Android device, find your video in the main Photos library or in Photos > Albums > Camera

Troubleshooting

Issue	Solution
Microphone is plugged in, but the volume meter does not register a signal.	Edit the privacy setting for your recording device under SETTINGS > PRIVACY > MICROPHONE to give the app permission to use the microphone.
Microphone is plugged in, but not detected.	Unplug and reconnect the cable connections so that the app recognizes the microphone. You'll know that the connection is secure when you see the microphone name visible in the status bar.

Issue	Solution
You hear no audio despite LEDs and the volume meter responding as if audio is present.	Check the Monitor Mix blend to ensure that audio is passing and you can monitor playback. Move the Monitor Mix slider to the center to hear audio that is being currently recorded and previously recorded audio.
Audio sounds bad or distant.	To ensure that you are receiving audio from the MOTIV microphone and not a built-in microphone; unplug and reconnect the microphone. You'll know that the connection is secure when you see the microphone name visible in the status bar.
Audio is distorted.	Use the audio meter to ensure that volume peaks are within the target range (the gray area). If the level reaches the red peak indicator of the input meter, turn the gain down.
Left/right stereo channels do not match video.	Depending on the orientation of the recording device, it may be necessary to engage the Left-Right swap in MOTIV settings. If the audio has already been recorded, you can switch the left and right channels in most audio editing software.
Audio is not in sync with video	Switch to a lower frame rate or resolution size. You might achieve better performance with a less system intensive frame rate.
Unable to share file.	<p>If a file is too large to be shared, there are a couple options for reducing file size.</p> <p>Convert your file to a compressed file format.</p> <p>Connect your mobile device to your computer and use file transfer, like iTunes, to download the file to your desktop.</p> <p>Split your track in two, export both files and recombine them using audio editing software.</p>
General troubleshooting.	<p>Ensure that your app is updated to the most current version.</p> <p>Make sure that your phone's operating system is updated to the most current version.</p> <p>Check to see how the microphone works using a different connection cable or different device.</p> <p>Close and restart the application.</p> <p>Powering down and rebooting the device will clear the cache and can sometimes help with software performance.</p>

Note: It may be useful to reset the app to restore functionality. Perform a hard reset by unplugging and re-plugging the microphone.

System Requirements

System Requirements and Compatibility: iOS

- **iOS:** iOS 12 and higher
- **iPhone:** iPhone 6 and higher
- **iPod Touch:** 6th gen

System Requirements and Compatibility: Android

Will work with any Android device that has:

- Android Oreo 8.0 and higher
- USB Host Power Requirement of ≥ 100 mA
- USB Audio Class 1.1 support and higher

Android is a trademark of Google Inc.

Specifications

MFi Certified

Yes

DSP Modes (Presets)

Speech/Singing/Acoustic/Loud/Flat

Polar Pattern

Adjustable Width Stereo/Mono Bidirectional/Mono Cardioid/Mid-Side

Stereo Principle

Mid-Side

Supported Audio Format

iOS

WAV, AAC (Up to 256 KHz)

Supported Audio Format

Android

AAC (Up to 256 KHz)

Frequency Response

20 Hz to 20,000 Hz

Adjustable Gain Range

0 to +36 dB

Sensitivity

-37 dBFS/Pa at 1 kHz ^[1] ^[2]

Maximum SPL

120 dB SPL ^[2]

Limiter

Yes

Compressor

Yes

Equalizer

5-band

^[1] 1 Pa=94 dB SPL^[2] At Minimum Gain, Flat Mode

Bit Depth	Sampling Rate
24	48 kHz
24	44.1 kHz
16	48 kHz
16	44.1 kHz

Supported Audio Formats

Android

PCM/WAV	Up to 352 KHz
AAC	256, 128, 96

iOS

PCM/WAV	Up to 352 KHz
MP4 Audio	Audio file extensions: .mp4, .m4a, .m4p, .m4b
AAC	256, 128, 96

Certifications

Industry Canada ICES-003 Compliance Label: CAN ICES-3 (B)/NMB-3(B)

Note: Testing is based on the use of supplied and recommended cable types. The use of other than shielded (screened) cable types may degrade EMC performance.

This product meets the Essential Requirements of all relevant European directives and is eligible for CE marking.

The CE Declaration of Conformity can be obtained from: www.shure.com/europe/compliance

Authorized European representative:

Shure Europe GmbH

Headquarters Europe, Middle East & Africa

Department: EMEA Approval

Jakob-Dieffenbacher-Str. 12

75031 Eppingen, Germany

Phone: +49-7262-92 49 0

Fax: +49-7262-92 49 11 4

Email: info@shure.de



Made for iPhone Xs Max, iPhone Xs, iPhone XR, iPhone X, iPhone 8 Plus, iPhone 8, iPhone 7 Plus, iPhone 7, iPhone SE, iPhone 6s Plus, iPhone 6s, iPhone 6 Plus, iPhone 6, iPhone 5s, iPhone 5c, iPhone 5, iPad Pro (10.5-inch), iPad Pro (12.9-inch) 2nd generation, iPad Pro (12.9-inch) 1st generation, iPad Pro (9.7-inch), iPad mini 4, iPad mini 3, iPad mini 2, iPad Air 2, iPad Air, iPad (6th generation), iPad (5th generation), iPad (4th generation), iPod touch.

iPad, iPhone, iPod, and iPod touch are trademarks of Apple Inc., registered in the U.S. and other countries. iPad Air, iPad mini, and Lightning are trademarks of Apple Inc. The trademark "iPhone" is used in Japan with a license from Aiphone K.K.

PIXI[®] and Manfrotto[®] are registered trademarks of Vitec Imaging Solutions. Mini tripod maximum weight: 1Kg/2.2 lbs.