



# **PL-1000 PINSPOUT PAR LIGHT**

user manual

©2018 ADJ PRODUCTS LLC all rights reserved. Information, specifications, diagrams, images, and instructions herein are subject to change without notice. ADJ logo and identifying product names and numbers herein are trademarks of ADJ PRODUCTS LLC. Copyright protection claimed includes all forms and matters of copyrightable materials and information now allowed by statutory or judicial law or hereinafter granted. Product names used in this document may be trademarks or registered trademarks of their respective companies and are hereby acknowledged. All non-ADJ brands and product names are trademarks or registered trademarks of their respective companies.

**ADJ PRODUCTS LLC** and all affiliated companies hereby disclaim any and all liabilities for property, equipment, building, and electrical damages, injuries to any persons, and direct or indirect economic loss associated with the use or reliance of any information contained within this document, and/or as a result of the improper, unsafe, insufficient and negligent assembly, installation, rigging, and operation of this product.

**ADJ PRODUCTS LLC USA**

6122 S. Eastern Ave. Los Angeles, CA. 90040  
323-582-2650 | Fax 323-532-2941 | [www.adj.com](http://www.adj.com) | [info@adj.com](mailto:info@adj.com)

**ADJ SUPPLY Europe B.V**

Junostraat 2 6468 EW Kerkrade, The Netherlands  
+31 (0)45 546 85 00 | Fax +31 45 546 85 99 | [www.adj.eu](http://www.adj.eu) | [info@americandj.eu](mailto:info@americandj.eu)

**ADJ PRODUCTS GROUP Mexico**

AV Santa Ana 30 Parque Industrial Lerma, Lerma, Mexico 52000  
+52 (728) 282-7070 | [ventas@adj.com](mailto:ventas@adj.com)

**CUSTOMER SUPPORT**

Contact ADJ Service for any product related service and support needs. Please visit [forums.adj.com](http://forums.adj.com) with questions, comments or suggestions.

**REPLACEMENT PARTS** please visit [parts.americandj.com](http://parts.americandj.com)

**ADJ SERVICE USA - Monday - Friday 8:00am to 4:30pm PST**

800-322-6337 | Fax 323-832-2941 | [support@adj.com](mailto:support@adj.com)

**ADJ SERVICE EUROPE - Monday - Friday 08:30 to 17:00 CET**

+31 45 546 85 60 | Fax +31 45 546 85 96 | [support@adj.eu](mailto:support@adj.eu)

**D O C U M E N T V E R S I O N**

An updated version of this document may be available online. Please check [www.adj.com](http://www.adj.com) for the latest revision/update of this document before beginning installation and use.

Date	Document Version	Notes
08/20/18	1	Initial release.

# CONTENTS

General Information	4
Limited Warranty (USA Only)	6
Safety Guidelines	7
Maintenance Guidelines	8
Overview	9
Installation Instructions	10
Trouble Shooting Tips	14
Frequently Asked Questions	14
Technical Specifications and Optional Accessories	15

# GENERAL INFORMATION

## INTRODUCTION

Please read and understand all instructions in this manual carefully and thoroughly before attempting to operate these products. These instructions contain important safety and use information.

## UNPACKING

The product has been thoroughly inspected and has been shipped in perfect operating condition. Carefully check the shipping carton for damage that may have occurred during shipping. If the carton appears to be damaged, carefully inspect each unit included for damage and be sure all accessories necessary to operate the units have arrived intact. In the event damage has been found or parts are missing, please contact our customer support team for further instructions. Please do not return this kit to your dealer without first contacting customer support at the number listed below. Please do not discard the shipping carton in the trash. Please recycle whenever possible.

## CUSTOMER SUPPORT

ADJ provides a customer support line, to provide set up help and to answer any question should you encounter problems during your set up or initial operation. You may also visit us on the web at [www.adj.com](http://www.adj.com) for any comments or suggestions. For service related issue please contact ADJ.

**ADJ SERVICE USA - Monday - Friday 8:00am to 4:30pm PST**

**323-582-2650 | Fax: 323-532-2941 | [support@americandj.com](mailto:support@americandj.com)**

## WARRANTY RETURNS

All returned service items whether under warranty or not, must be freight pre-paid and accompany a return authorization (R.A.) number. The R.A. number must be clearly written on the outside of the return package. A brief description of the problem as well as the R.A. number must also be written down on a piece of paper and included in the shipping container. If the unit is under warranty, you must provide a copy of your proof of purchase invoice. Items returned without a R.A. number clearly marked on the outside of the package will be refused and returned at customer's expense. You may obtain a R.A. number by contacting customer support.

## LIMITED WARRANTY (USA ONLY)

- A. ADJ Products, LLC hereby warrants, to the original purchaser, ADJ Products, LLC products to be free of manufacturing defects in material and workmanship for a prescribed period from the date of purchase (see specific warranty period on reverse). This warranty shall be valid only if the product is purchased within the United States of America, including possessions and territories. It is the owner's responsibility to establish the date and place of purchase by acceptable evidence, at the time service is sought.
- B. **For warranty service, you must obtain a Return Authorization number (RA#) before sending back the product-please contact ADJ Products, LLC Service Department at 800-322-6337.** Send the product only to the ADJ Products, LLC factory. All shipping charges must be pre-paid. If the requested repairs or service (including parts replacement) are within the terms of this warranty, ADJ Products, LLC will pay return shipping charges only to a designated point within the United States. If the entire instrument is sent, it must be shipped in its original package. No accessories should be shipped with the product. If any accessories are shipped with the product, ADJ Products, LLC shall have no liability whatsoever for loss of or damage to any such accessories, or for the safe return thereof.
- C. This warranty is void if the serial number has been altered or removed; if the product is modified in any manner which ADJ Products, LLC concludes, after inspection, affects the reliability of the product, if the product has been repaired or service by anyone other than ADJ Products, LLC factory unless prior written authorization was issued to purchaser by ADJ Products, LLC; if the product is damaged because not properly maintained as set forth in the instruction manual.
- D. This is not a service contract, and this warranty does not include maintenance, cleaning or periodic check up. During the period specified above, ADJ Products, LLC will replace defective parts at its expense with new or refurbished parts, and will absorb all expenses for warrant service and repair labor by reason of defects in material or workmanship. The sole responsibility of ADJ Products, LLC under this warranty shall be limited to the repair of the product, or replacement thereof, including parts, at the sole discretion of ADJ Products, LLC. All products covered by this warranty were manufactured after August 15, 2012, and bear identifying marks to that effect.
- E. ADJ Products, LLC reserves the right to make changes in design and/or improvements upon its products without any obligation to include these changes in any products theretofore manufactured.
- F. No warranty, whether expressed or implied, is given or made with respect to any accessory supplied with products described above. Except to the extent prohibited by applicable law, all implied warranties made by ADJ Products, LLC in connection with this product, including warranties of merchantability or fitness, are limited in duration to the warranty period set forth above. And no warranties, whether expressed or implied, including warranties of merchantability or fitness, shall apply to this product after said period has expired. The consumer's and/or Dealer's sole remedy shall be such repair or replacement as is expressly provided above; and under no circumstances shall ADJ Products, LLC be liable for any loss or damage, direct or consequential, arising out of the use of, or inability to use, this product.
- G. This warranty is the only written warranty applicable to ADJ Products, LLC Products and supersedes all prior warranties and written descriptions of warranty terms and conditions heretofore published.

### LIMITED WARRANTY PERIODS

- **Non L.E.D. Lighting Products = 1-year (365 days) Limited Warranty** (Such as: Special Effect Lighting, Intelligent Lighting, UV lighting, Strobes, Fog Machines, Bubble Machines, Mirror Balls, Par Cans, Trussing, Lighting Stands etc. excluding LED and lamps)
- **Laser Products = 1 Year (365 Days) Limited Warranty** (excludes laser diodes which have 6 month limited warranty)
- **L.E.D. Products = 2-year (730 days) Limited Warranty** (excluding batteries which have a 180 day limited warranty)  
Note: 2 Year Warranty only applies to purchases within the United States.
- **StarTec Series = 1 Year Limited Warranty** (excluding batteries which have a 180 day limited warranty)
- **ADJ DMX Controllers = 2 Year (730 Days) Limited Warranty**

# SAFETY INSTRUCTIONS AND GUIDELINES

To guarantee a smooth operation, it is important to follow all instructions and guidelines in this manual. ADJ PRODUCTS LLC is not responsible for injury and/or damages resulting from the misuse of these devices due to the disregard of the information printed in this manual. Only qualified and/or certified personnel should perform installation of these devices and only the original rigging parts included with these devices should be used for installation. Any modifications to these devices and/or the included mounting hardware will void the original manufactures warranty and increase the risk of damage and/or personal injury.



## **PROTECTION CLASS 1 – DEVICES MUST BE PROPERLY GROUNDED**



**THERE ARE NO USER SERVICEABLE PARTS INSIDE THIS DEVICE. DO NOT ATTEMPT ANY REPAIRS YOURSELF; DOING SO WILL VOID YOUR MANUFACTURES WARRANTY. DAMAGES RESULTING FROM MODIFICATIONS TO THIS DEVICE AND/OR THE DISREGARD OF SAFETY INSTRUCTIONS AND GUIDELINES IN THIS MANUAL VOID THE MANUFACTURES WARRANTY AND ARE NOT SUBJECT TO ANY WARRANTY CLAIMS AND/OR REPAIRS.**



**NEVER TOUCH LIGHT DURING OPERATION, AS IT MAY BE HOT!  
ALWAYS DISCONNECT FROM THE MAIN POWER BEFORE REPLACING LAMPS!  
ALWAYS REPLACE WITH SAME LAMPS AND FUSES!  
KEEP FLAMMABLE MATERIALS AWAY FROM THESE DEVICES!**



**INDOOR / DRY LOCATIONS USE ONLY!  
DO NOT EXPOSE DEVICES TO RAIN AND/OR MOISTURE!**



**NEVER LOOK DIRECTLY INTO THE LIGHT SOURCE!  
RETINA INJURY RISK - MAY INDUCE BLINDNESS!  
SENSITIVE PERSONS MAY SUFFER AN EPILEPTIC SHOCK!**

# SAFETY INSTRUCTIONS AND GUIDELINES

**DO NOT** position devices close to any **FLAMMABLE MATERIALS** while operating.

**DO NOT** attempt installation and/or operation of devices without knowledge how to do so.

**DO NOT** permit operation by persons who are not qualified to operate these types of devices.

**DO NOT** shake devices, avoid brute force when installing and/or operating.

**DO NOT** operate these devices if the main power cord has become frayed, crimped and/or damaged. Replace any damaged power cords with a similar power rating.

**DO NOT** remove or break-off the ground plug from the device power cords.

**DO NOT** remove disassemble devices, there are NO user serviceable parts inside.

**ALWAYS** disconnect devices from main power source before performing any cleaning.

**ALWAYS** disconnect light from main power before replacing lamp.

**ALWAYS** be sure to install these devices in an area that will allow proper ventilation.

**NEVER** remove the ground prong from the power cable.

Power cords should be safely routed and secured so they are not likely pinched.

Disconnect power cords during long periods of non-use.

Only use recommended rigging hardware as described in this guide.

Use the original packaging and materials to transport these devices in for service.

These devices should be serviced by qualified service personnel when:

- The power cords or plugs have become damaged.
- Objects have fallen on and/or liquid has spilled into the devices.
- The devices have been exposed to rain and/or moisture.
- The devices do not operate normally or exhibit a marked change in performance.

# MAINTENANCE GUIDELINES



**DISCONNECT POWER BEFORE PERFORMING ANY MAINTENANCE!**

## **CLEANING**

Frequent cleaning is recommended to insure proper function, optimized light output, and an extended life. The frequency of cleaning depends on the environment in which the device operates in: damp, smoky or particularly dirty environments can cause greater accumulation of dirt on the mirror ball and/or light fixture optics. Clean the external surface of the mirror ball and the front lens of the light at least every 20 days with a soft cloth to avoid dirt/debris accumulation

**NEVER** use alcohol, solvents, or ammonia-based cleaners.

## **MAINTENANCE**

Regular inspections are recommended to insure proper function and extended life.

There are no user serviceable parts inside these devices, please refer all other service issues to an authorized ADJ service technician. Should you need any spare parts, please order genuine parts from your local ADJ dealer.

Please refer to the following points during routine inspections:

A detailed review by an approved electrical engineer every three months, to make sure the circuit contacts are in good condition and prevent overheating.

Be sure all screws and fasteners are securely tightened at all times. Loose screws may fall out during normal operation resulting in damage or injury as larger parts could fall.

Check for any deformations on the mirror ball, mirror ball motor, and light housings, lenses, rigging hardware and rigging points (ceiling, suspension, trussing). Deformations could allow for dust to enter into the devices. Damaged rigging points or unsecured rigging could cause the devices to fall and seriously injure a person(s).

Electric power supply cables must not show any damage, material fatigue or sediments.



# OVERVIEW

## INCLUDED ITEMS

(1) Pinspot Par Light (PL-1000)



1. Light Housing
2. Light Bulb (LL-4515)
3. Yoke / Mounting Bracket
4. 4-Point Knob
5. Power Cord

# INSTALLATION INSTRUCTIONS



## **FLAMMABLE MATERIAL WARNING**

Keep devices minimum 5.0 feet (1.5m) away from flammable materials and/or pyrotechnics.



## **ELECTRICAL CONNECTIONS**

A qualified electrician should be used for all electrical connections and/or installations.



## **DO NOT INSTALL THE DEVICES IF YOU ARE NOT QUALIFIED TO DO SO!**

**OVERHEAD RIGGING REQUIRES EXTENSIVE EXPERIENCE, INCLUDING AMONGST OTHERS CALCULATING WORKING LOAD LIMITS, INSTALLATION MATERIAL BEING USED, AND PERIODIC SAFETY INSPECTION OF ALL INSTALLATION MATERIAL AND THE MOTOR. IF YOU LACK THESE QUALIFICATIONS, DO NOT ATTEMPT THE INSTALLATION YOURSELF. IMPROPER INSTALLATION CAN RESULT IN BODILY INJURY.**

**BEFORE RIGGING/MOUNTING DEVICES TO ANY METAL TRUSS/STRUCTURE OR CEILING, A PROFESSIONAL EQUIPMENT INSTALLER MUST BE CONSULTED TO DETERMINE IF THE METAL TRUSS/STRUCTURE OR CEILING IS PROPERLY CERTIFIED TO SAFELY HOLD THE COMBINED WEIGHT OF THE LIGHT FIXTURE<sup>1</sup>, CLAMPS, CABLES, AND ACCESSORIES.**

**BEFORE MOUNTING DEVICES TO ANY SURFACE OR STRUCTURE, MAKE SURE THE SURFACE OR STRUCTURE CAN HOLD A MINIMUM POINT LOAD OF 10 TIMES THE WEIGHT OF THE DEVICES.**

**MAKE SURE SCREWS AND/OR ANCHOR BOLTS (NOT INCLUDED) FIT INTO MOUNTING HOLES!**

**MAKE SURE TO DRILL SCREWS AND/OR ANCHOR BOLTS INTO WOOD OR METAL!**

**DO NOT MOUNT THE MOTOR TO A CEILING SURFACE MADE OF DRY WALL!**

**MOTOR MUST ONLY BE INSTALLED IN A VIBRATION-FREE POSITION!**

**MOTOR MUST ONLY BE INSTALLED IN AN OSCILLATION-FREE LOCATION!**

**FOR ADDED PROTECTION, MOUNT DEVICES IN AREAS OUTSIDE WALKING PATHS, SEATING AREAS, OR IN AREAS WHERE UNAUTHORIZED PERSONNEL CAN REACH THE DEVICES.**

**SECURE MIRROR BALL WITH A SECONDARY SAFETY ATTACHMENT, SUCH AS AN APPROPRIATE SAFETY CABLE. (NOT INCLUDED)**

**NEVER STAND DIRECTLY BELOW THE DEVICES WHEN MOUNTING, REMOVING OR SERVICING.**

**DEVICES MUST ALL BE INSTALLED FOLLOWING ALL LOCAL, NATIONAL, AND COUNTRY COMMERCIAL ELECTRICAL AND CONSTRUCTION CODES AND REGULATIONS.**

**DO NOT EXCEED AMBIENT OPERATING TEMPERATURE RANGE OF 140°F. (60°C)**

# INSTALLATION [continued]

## AIMING THE LIGHT SOURCE

Experiment with different angles and distances before mounting light to achieve desired result.

## MOUNTING LIGHT SOURCE

Light can be mounted onto a truss using an ADJ (not included) clamp, or to a flat surface using the mounting yoke holes along the inside. Ceiling surface must support 10 times the total weight of the light. **Please consult a professional for ceiling installation guidance.**



## ADJUSTING THE AIM

To adjust the aim of the fixture, loosen the 4-point knobs on each side of the yoke by turning counter-clockwise. Adjust light as needed and tighten knobs by turning knobs clockwise.



## TO REPLACE LAMP

Unscrew ring on the head of the fixture. Replace bulb and reassemble.

## TROUBLE SHOOTING TIPS

### The light does not turn on

1. Confirm the motor has AC power.
2. Check if circuit breaker that controls the AC outlet the light is plugged into is not tripped.
3. Confirm the AC power cord from the light is not damaged or cut.
4. Confirm the light bulb is not damaged or loose.
5. If none of these solutions work, please contact ADJ Customer Service.

## FREQUENTLY ASKED QUESTIONS

Listed below are a few answers to common questions users may have.

### 1. Can the PL-1000 be mounted onto to a ceiling?

Yes, it can be installed onto a flat ceiling surface that can support 10 times the combined total weight of the attached fixture and any mounting accessories. Careful planning must be used when calculating the combined weight and determining if the flat ceiling surface can support the weight of the fixture. **PLEASE CONSULT A PROFESSIONAL FOR CEILING INSTALLATION GUIDANCE!**

### 2. What is the replacement bulb?

Replacement Lamp: 6V 30W Halogen PAR-36 (LL-4515)

### 3. Is there a replacement fuse?

No, the PL-1000 does not have a replacement fuse.

### 4. How do you clean the light fixture?

Clean the external surface and lens at least every 20 days with a soft cloth to avoid dirt/debris accumulation. **NEVER** use alcohol, solvents, or ammonia-based cleaners.

### 5. Is the light DMX compatible?

No. However, a variety of lighting fixtures and options are available at [www.adj.com](http://www.adj.com).

# TECHNICAL SPECIFICATIONS

## PL-1000 Pinspot Par Light

INDOOR USE ONLY

Par 36 Metal Pinspot with screw on front cap and 4-foot power cord (no fuse protection)

### DIMENSIONS/LAMP

Dimensions: 6.75x5.75" (171x146mm)

Weight: 3.2 lbs. (1.45 kg)

Lamp: 4515 6V 30W, Par 36

Specifications subject to change without any prior written notice.

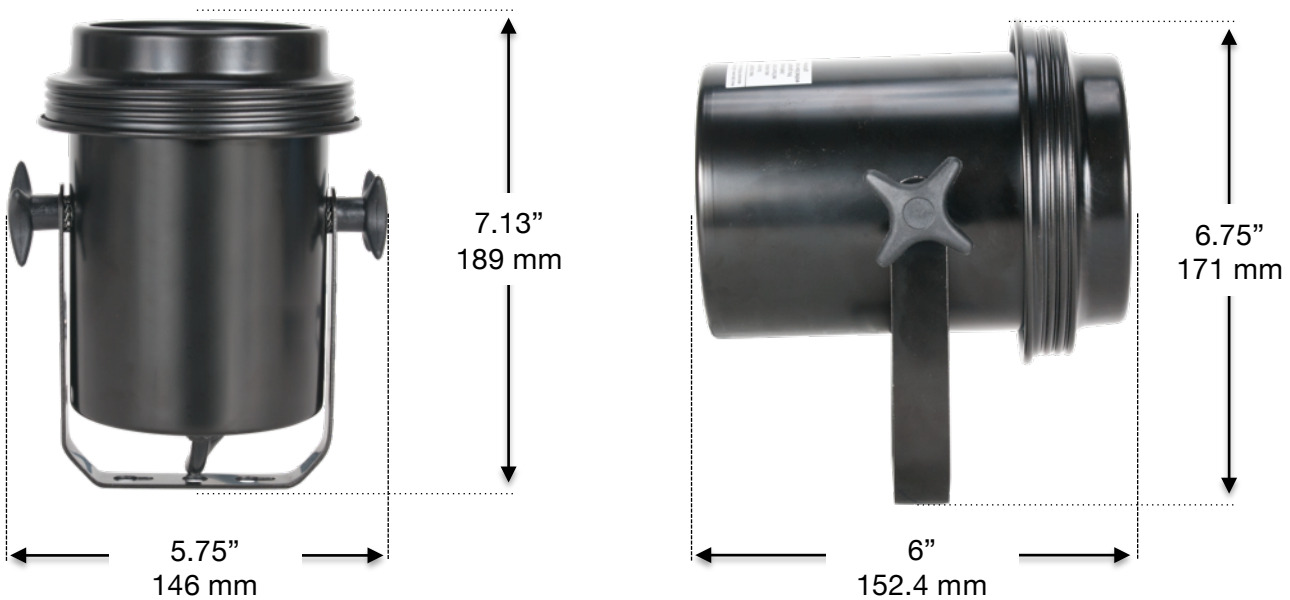

# OPTIONAL ACCESSORIES

Order Code	Description
O-Clamp	Truss O-Clamp available in 3 sizes: 2, 1.5, & 1
LL-4515	Replacement Lamp: 6V 30W Halogen PAR-36 – LL-4515
S-CABLE 60	Safety Cable 60lb Rating, 24" Length
M-1616	16" (51cm) Mirror Ball

