



Specifications: RS31-EZ

System Type	3 inch full-range, pendant mount speaker
Impedance (nominal) ¹	8 ohm
Sensitivity dB @ 2.83 V/1 m	85.0 dB
Sensitivity dB @ 1 W/1 m ²	85.0 dB
Frequency Response (-3 dB) ³	170 Hz - 14 kHz
Frequency Response (-10 dB) ³	120 Hz - 22 kHz
Max. Program Power ⁴	40 W
Max. Continuous Power RMS ⁵	20 W
Max. Power SPL @ 1 m ⁶	98.0 dB
Coverage Angle (-6 dB @ 2 kHz)	70°
Coverage Angle (-6 dB @ 10 kHz)	45°
Coverage Angle (averaged from 2 to 10 kHz)	85°
Directivity Factor (Q)	4.9 (averaged 100Hz - 10kHz), 7.1 (2kHz)
Directivity Index (DI) dB	5.1 (averaged 100Hz - 10kHz), 8.5 (2kHz)
Tap Selector	Selectable terminal input strip
Transducer - Full-Range Driver	76.1 mm (3.0 in.) Polypropylene driver with butyl rubber surround
Enclosure Material	Injection molded ABS
Grille	Corrosion-resistant, powder-coated aluminum
Inputs	Terminal strip
Colors	Black or white
Height	125.4 mm (4.9 in.)
Height (with stabilizing arm)	139.7 mm (5.5 in.)
Diameter	110.4 mm (4.4 in.)
Weight	0.6 kg (1.3 lbs.)
Shipping Weight	0.9 kg (2.0 lbs.)
Packaging	One per box
Included Accessories	Ceiling mount, cover plate, and 10 ft speaker signal/hanging cable
Optional Accessories	N/A
Regulatory - UL	UL 1480 (UEAY) approved
Regulatory - CE	Approved
RoHS	Approved

¹ Impedance listed per IEC 60268-5 with a minimum less than 80% the nominal impedance

² 1 W 1 m sensitivity determined using nominal impedance

³ Frequency response measured in half or full space as dictated by speaker mounting configuration

⁴ Max program power is 3 dB above max continuous power

⁵ Continuous power rating, EIA-426-B test

⁶ Max output based on max continuous power

Key Features

- 3 inch one (76.1 mm) polypropylene driver with butyl rubber surround
- Weatherized components for indoor/outdoor applications.
- Ultra-low profile ZeroReflection™ ABS enclosure (4.35 in diameter by 4.35 in height without stabilizing arm.)
- Corrosion-resistant, powder-coated aluminum grille.
- UL 1480 (UEAY) approved
- High quality black or white paint finish.
- Included accessories: Mounting element, cover plate, 10ft speaker signal/hanging cable.

Description

The RS31-EZ is a premium full-range 3 inch pendant-mount speaker, with overall dimensions smaller than a 4 inch sphere. The RS31-EZ incorporates a 10ft length of speaker signal/hanging cable for on-ceiling applications. Components have been weatherized for indoor/outdoor applications.

The RS31-EZ is an 8 ohm speaker without transformer. The speaker utilize the all-in-one ceiling mount system designed to retrofit in most j-boxes. Cover plate is included to hide mounting element and hold excess signal/hanging cable.

Applications

Engineered for rapid installation and low profile mounting for smaller venues, the RS31-EZ is ideal for finished ceiling applications in retail, restaurants, conference rooms, patio areas, educational facilities or any setting where full-range intelligibility, unobtrusive design and installation ease are paramount.



Patented SoundTube Technologies

SoundTube Entertainment and the MSE Audio Group constantly develop new technologies which enhance audio product performance. SoundTube Entertainment innovations are protected by multiple U.S. and international patents, which explicitly cover SoundTube dome, enclosure and dispersion technologies. The MSE Audio Group actively defends its patents in order to protect SoundTube resellers and end-users.

Technical Data and Specification Tools

Technical Data

SoundTube Entertainment strives to provide complete and effective technical information and data to dealers, engineers and designers. All data are available from SoundTube Entertainment or at www.soundtube.com.

Technical data and downloads include:

EASE™ data – 3-D polar plots.

EASE™ Address – 2-D modeling for distributed systems

Autodesk® Revit® software

Tech Sheets – Technical information and architectural specs for system engineers

SoundTubeSPEC™ – Proprietary speaker placement software

Acquisition and Verification

All data for SoundTube speakers are independently collected from and verified by NWAALabs (www.nwaalabs.com) using their proprietary MACH testing system. All data are collected and analyzed according to ASTM, ISO and AES standards using EASERA, TEF and MLSSA. Full balloon data including both phase and magnitude is compiled into a variety of formats including EASE 4.x, GLL and CLF.

Architectural Specifications

The loudspeaker transducer shall consist of one full-range 76.1mm (3.0in.) polypropylene cone with butyl rubber surround.

Performance specifications for a typical production unit shall be as follows: Useable frequency response shall extend from 120Hz – 22kHz (-10dB). Measured sensitivity (2.83volt input, 1 meter) shall be at least 85.0dB. Rated power capacity shall be at least 20watts continuous (RMS) and conform to EIA-426-B. Maximum continuous power output at 1 meter shall be 98dB.

Installation shall be by mounting element designed to retro-fit in most junction boxes. The speaker will hang via 10foot signal/hanging cable (included). Cover plate is included to store excess signal/hanging cable as it is screwed into place, concealing the mounting element and junction box. The speaker utilizes weatherized components for indoor and outdoor applications.

External wiring shall be by low-profile screw terminal and shall accept from 10–22-gaugewire.

The enclosure shall be constructed of injection-molded, ABS. The grille shall be constructed of powder-coated aluminum for lasting performance and affix to the speaker baffle via pressure fit. Overall cabinet dimensions shall be no more than 125.4mm (4.9in.) in height by 110.4mm (4.4in.) in diameter. The unit height with stabilizing arm shall be no more than 139.7mm (5.5in.).

The system shall be the RS31-EZ for low-impedance applications.

SoundTube Entertainment

13720 W 109th St.

Lenexa, KS 66215

Phone 913.663.5600

Fax 913.663.3200

Toll Free 800.647.TUBE

www.soundtube.com

All SoundTube products come with a 5-year limited warranty.



Graphs and Plots

Frequency Response

Phase/Impedance Response

Vertical Beamwidth (-6 dB)

Directivity Index (DI)

Polar Plots

—— Horizontal
 - - - - Vertical

125 Hz

250 Hz

500 Hz

1,000 Hz

2,000 Hz

4,000 Hz

8,000 Hz

10,000 Hz

Technical data, EASE™ plots, SoundTubeSPEC™ software and product downloads available at www.soundtube.com

Mechanical Drawings

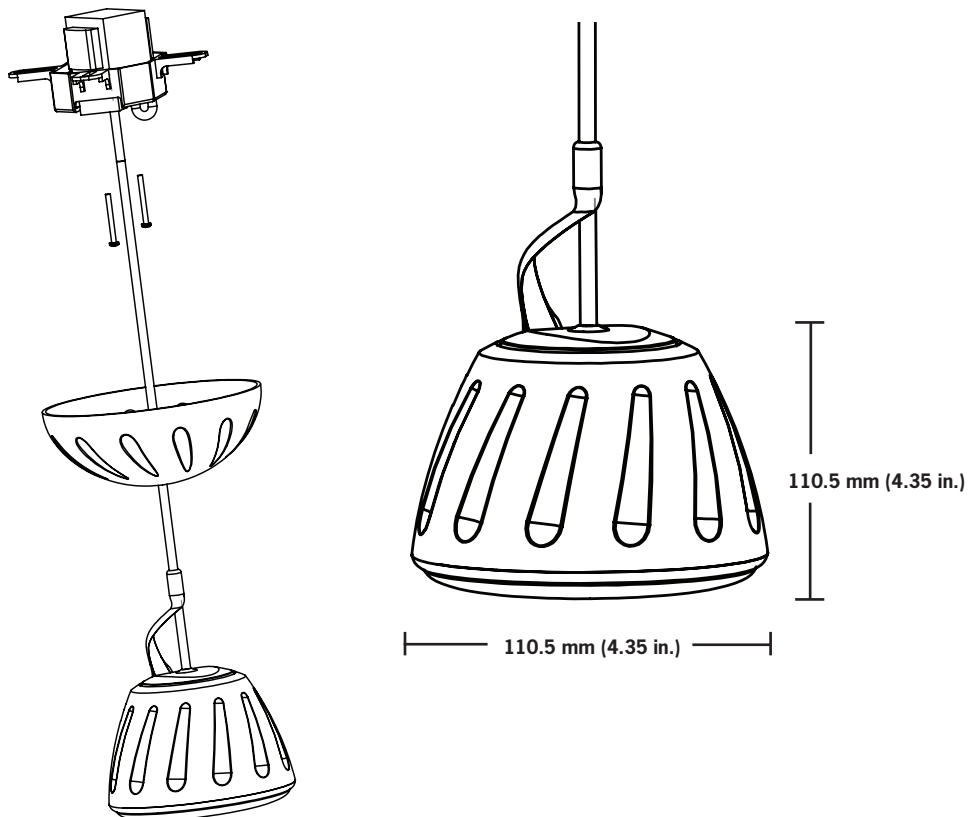

SoundTube Entertainment manufactures a complete line of speakers for:
Open-Ceiling • In-Ceiling • Surface-Mount • Outdoor • Sound-Focusing

All SoundTube products are designed and engineered in the USA.