

Contents

| | |
|--|----------|
| Key Features | 2 |
| Modules | 3 |
| Block Diagram - Inputs | 4 |
| Block Diagram - Master Section | 5 |
| Typical Specifications | 6 |
| Dimensions | 7 |
| Architect's and Engineer's Specifications | 8 |





Technical Data

Key Features

16, 24 and 32 channel configurations.

Individually switched 48V phantom power on every input module.

6 Aux sends.

4 Sub groups (paired).

6 X 2 Output Matrix.

GB30 mic pre-amp.

4-band GB30 EQ.

Integral power supply, with an external power supply link option.

All metal TRS jacks and Neutrik XLRs.

Direct outputs on all mono input channels.

GB 2

Technical Data

Modules

Mono Input

Stereo Input

Master Section

Soundcraft

GB 2

1

48V

MIC GAIN

LINE = 5 80dB

100Hz

HF

HI MID

LO MID

LF

EQ

AUX1 PRE

AUX2 PRE

AUX3 PRE

AUX4 PRE

AUX5 POST

AUX6 POST

PAN

MUTE

10 5 0 5 10 15

1-2

3-4

MIX

PK ●

SIG ●

PFL ●

+

1

STE1

48V

MIC GAIN

LINE TO MIX

LINE TO CHAN

LINE

MONO

L

R

HF

HI MID

LO MID

LF

EQ

AUX1 PRE

AUX2 PRE

AUX3 PRE

AUX4 PRE

AUX5 POST

AUX6 POST

BAL

MUTE

10 5 0 5 10 15

1-2

3-4

MIX

PK ●

SIG ●

PFL ●

+

STE1

HEADPHONES

48V

±17V

TALK BACK

AUX 1-4

GRPS

+18 +15 +12 +9 +6 +3 0 -3 -6 -9 -12 -15 -18 -20

L R

2 TK TO MIX

2 TK LEVEL

2TK

1-2

3-4

MIX

MONITOR SOURCE PFL

AFL

MONO

C/ROOM

H/PHONES

+

GRP 1

GRP 2

GRP 3

GRP 4

MIX L

MIX R

MTX 1

MTX 2

MUTE

AUX1

AUX2

AFL

AUX3

AFL

AUX4

AFL

AUX5

AFL

AUX6

AFL

WIDTH

MIX

PFL ●

GRP1 GRP2

+

10 5 0 5 10 15

+

10 5 0 5 10 15

+

10 5 0 5 10 15

+

1 GRP 2 **3 GRP 4** **MIX**

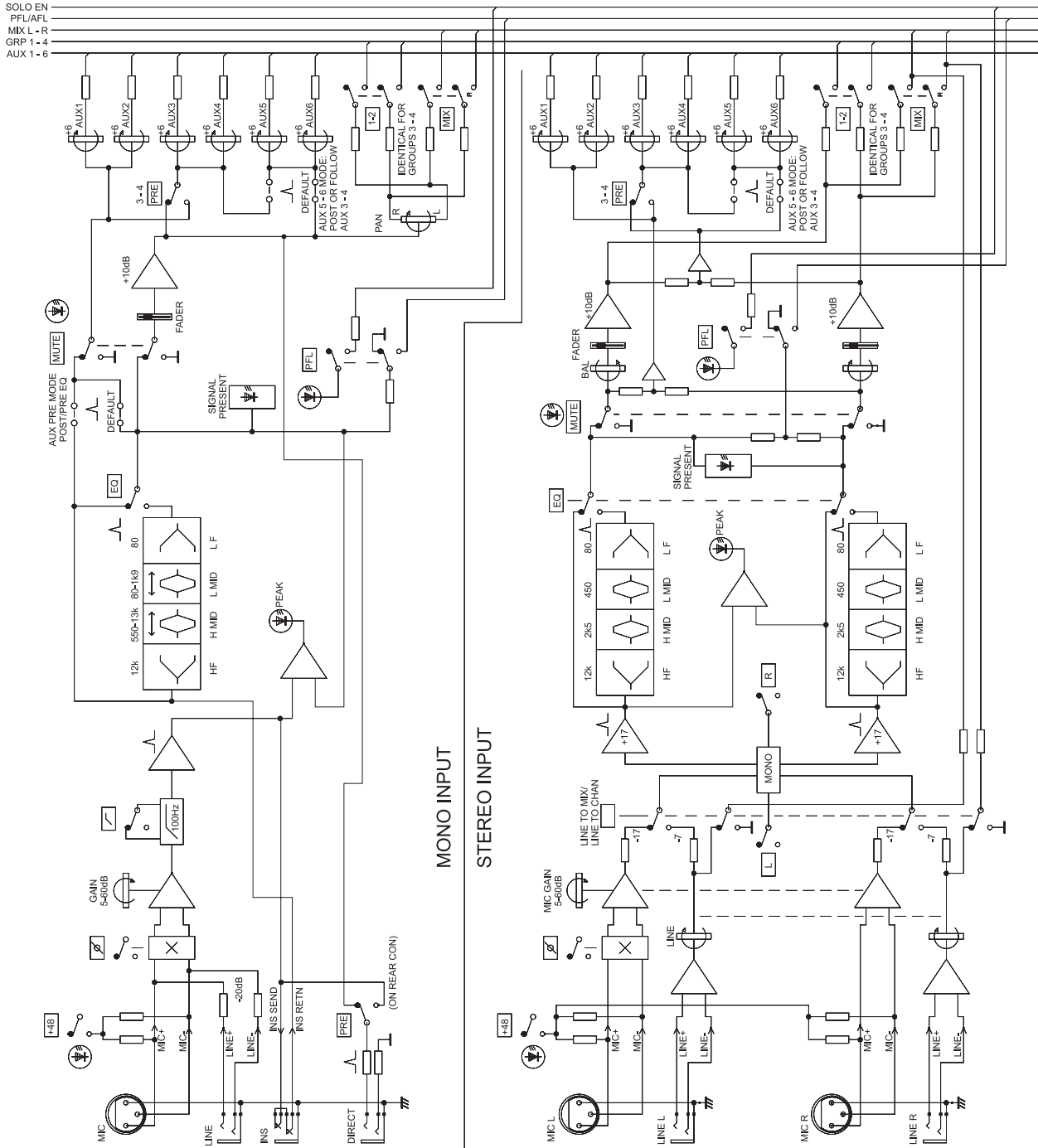

GB2

Technical Data Block Diagram - Master Section

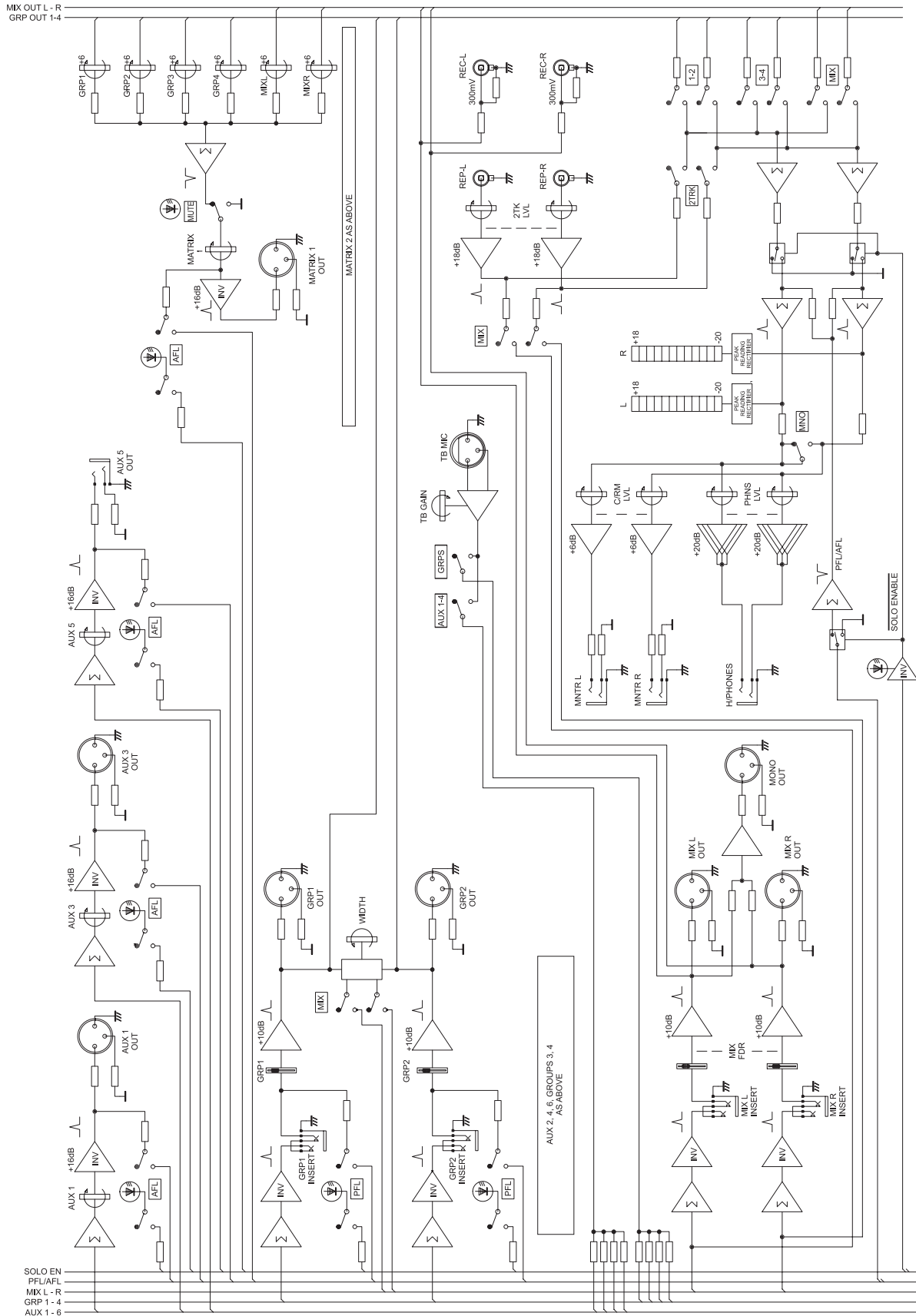



Technical Data

Typical Specifications

Noise

| | |
|--|---------|
| Measured RMS, 22Hz to 22kHz Bandwidth | |
| Mic E.I.N. @ unity gain, 150Ω source impedance | -128dBu |
| Mix Output, 32 inputs routed to mix | <-85dBu |
| Group Outputs | <-85dBu |
| Aux Outputs | <-83dBu |
| Matrix Outputs | <-89dBu |

Crosstalk (@1kHz, typical)

| | |
|------------------------------------|--------|
| Input Channel Mute | <-93dB |
| Input Fader cut-off | <-92dB |
| Pan isolation | <-70dB |
| Mix route isolation | <-93dB |
| Group route isolation | <-93dB |
| Adjacent channel crosstalk | <-99dB |
| Group to Mix | <-90dB |
| Aux Send pots offness (typical) | <-80dB |
| Matrix Send pots offness (typical) | <-80dB |

Frequency Response

| | |
|--|------|
| Mic/Line Input to any output, 20Hz - 20kHz | <1dB |
|--|------|

THD + N

| | |
|---|---------|
| Mic sens. -30dBu, +20dBu at all outputs @1kHz | <0.006% |
|---|---------|

CMRR

| | |
|----------------|------|
| Typical @ 1kHz | 80dB |
|----------------|------|

Input & Output Max Levels

| | |
|--------------------------|-------------------|
| Mono & Stereo Mic Inputs | +15dBu |
| Mono Line Inputs | +30dBu |
| Stereo Line Inputs | +20dBu |
| Insert Returns | +20dBu |
| Any output | +20dBu |
| Nominal Operating Level | 0dBu |
| Headphone Power | 2x250mW into 200Ω |

Input & Output Impedances

| | |
|--|-------------------------------|
| Mic Inputs | 2kΩ |
| Line Inputs and Stereo Returns | 10kΩ |
| Input channels Insert Return | 5kΩ with EQ in, otherwise 3kΩ |
| Mix, Group, Aux, Matrix & Direct outputs | 150Ω |
| Insert sends | 75Ω |
| Recommended Headphone Impedance | 50 - 600Ω |

Weight

| | |
|------------|------|
| 16 Channel | 22kg |
| 24Channel | 25kg |
| 32Channel | 30kg |

GB2

Technical Data Dimensions

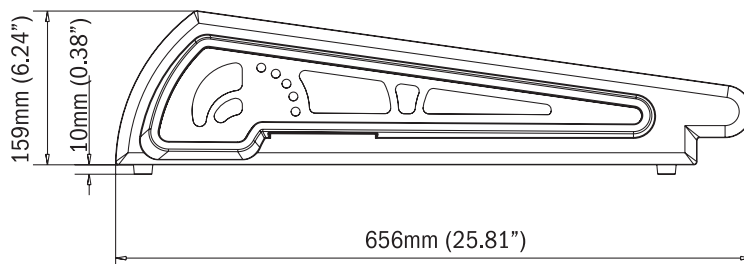
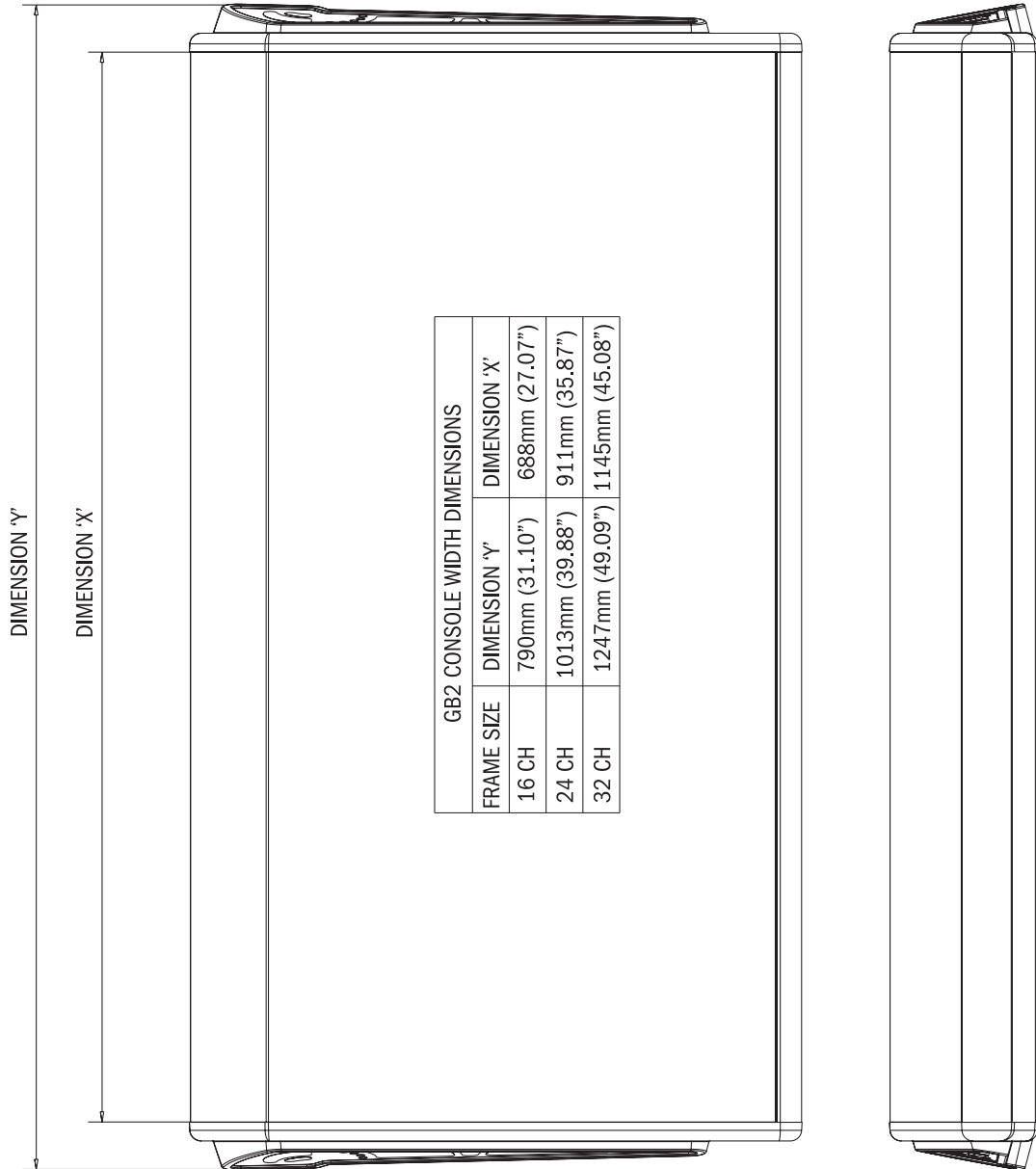



Technical Data

Architect's and Engineer's Specifications Soundcraft GB2 May 2006

The Mixing Console shall be constructed in an all-steel chassis, with removable side cheeks, and shall be available in 16, 24 and 32 input configurations. There shall be one PCB per channel and master section. There shall be one Main mix output, 4 Sub Group outputs arranged as 2 stereo pairs, 2 Matrix outputs, and L/R recording outputs. There shall be 6 auxiliary send outputs and Direct outputs on each channel with a switch to select the Direct Output to be sourced either pre or Post fade. There shall be 2 fully featured stereo Mic/Line channels. A Talkback facility shall be included, assignable to the Aux sends and Group outputs. A minimum of two lamp sockets shall be provided on each frame size. The unit will be supplied with an integral power supply and an optional external back-up supply shall be available.

Each Mono Input shall have a balanced low-impedance input via an XLR socket and a line-level ¼" balanced TRS connector. Input Gain shall be continuously variable from +5 dBu to +60 dBu, and a Peak LED shall also be provided. Phantom power will be switchable on an individual basis with an LED to indicate that it is active. There shall be a switchable 100Hz High Pass filter with an 18db per octave slope, along with a Phase switch. The EQ shall be a 4-band type with a Shelving HF at 12kHz, Shelving LF at 80Hz, and two sweepable mid-range controls from 80Hz - 1.9kHz, and 550Hz - 13kHz respectively. The Q for Mid-range control shall be fixed at 1.5. Gain shall be cut or boosted by 15db on all bands (centre detented). The EQ circuit shall be engaged via a switch. Six external Aux sends shall be provided. Auxes 1-2 shall be fixed pre-fader, 3-4 will be globally switchable between pre and post fader. Auxes 5-6 shall be fixed post-fader operation. All Aux sends will be post-mute and post EQ. There shall be a pre-EQ, pre-mute TRS ¼" insert point. Routing shall be assigned, post-pan, to the Mix, Group 1-2 and Group 3-4 buses via a switch adjacent to each fader. Faders shall be of the 100mm variety. There shall be provided a main channel Mute switch and Mute LED indicator, as well as a PFL switch and LED indicator. Each mono input channel shall have a peak and signal LED indicator adjacent to the channel fader.

Each Stereo Input shall have 2 x balanced low-impedance inputs via XLR sockets and 2 x line-level ¼" balanced TRS connectors. Input Gain shall be continuously variable from +5 dBu to +60 dBu, and phantom power will be switchable on an individual basis. There shall be a switchable Phase switch that reverses the phase of the Left input signal. Left Only/Right Only and Mono Sum switches shall be provided. The EQ shall be a 4-band fixed frequency type. Gain shall be cut or boosted by 15db on all bands (centre detented). The EQ circuit shall be engaged via a switch. Six external Aux sends shall be provided. Auxes 1-2 shall be fixed pre-fader, 3-4 will be globally switchable between pre and post fader. Auxes 5-6 shall be fixed post-fader operation. All Aux sends will be post-mute and post EQ. Routing shall be assigned, post-pan, to the Mix, Group 1-2 and Group 3-4 buses via a switch adjacent to each fader. Faders shall be of the 100mm variety. There shall be provided a main channel Mute switch and Mute LED indicator, as well as a PFL switch and LED indicator. Each stereo input channel shall have a peak and signal LED indicator adjacent to the channel fader.

There shall be 4 sub group busses arranged as 2 stereo pairs on 100mm faders situated to the left of the Mix fader. Outputs will be routed to dedicated balanced XLR jacks with TRS insert points. A switch to route Group channels to the mix bus will be provided along with a mono/stereo width control and PFL buttons for each individual group bus.

The Master section shall consist of one 100mm master fader which controls the mix bus master level. Six master Aux sends with AFL switches shall be provided. Two Matrix Master controls will be included with an AFL and mute button for each Matrix. A Talkback facility, assignable to the Aux sends (in pairs) and Group outputs shall be provided. There shall be a 12 segment multi-coloured LED meter switchable between the 2 Track, Groups 1-2 and 3-4 and the mix output. The Monitoring section shall allow the selection of either the 2 Track, Groups 1-2 and 3-4 and the mix output to the headphones and Control Room speaker outputs. A 2 Track to Mix button shall also be provided that allows the Main stereo mix output to be replaced by the 2 Track input. A ¼" stereo headphone jack will be provided with dedicated level control. Master outputs shall be balanced XLR with ¼" TRS inserts available

The console dimensions and weight shall be published in product literature according to frame size. The console shall be the **Soundcraft GB2**.



H A Harman International Company

SOUNDCRAFT, Harman International Industries Ltd., Cranborne House, Cranborne Road, Potters Bar, Herts., EN6 3JN U.K.
Tel: +44 (0) 1707 665000 Fax: +44 (0) 1707 660742 EMAIL: info@soundcraft.com

SOUNDCRAFT USA, Harman Pro North America, 8500 Balboa Blvd., Northridge, CA 91329, USA
Main tel: +1 818 920 3212, Main fax: +1 818 920 3208, Direct toll free: 888 251 8352
EMAIL: soundcraft-usa@harman.com

www.soundcraft.com