



# Forum™ (IMA-240)

## Classroom Audio System Installation Manual



# Welcome

Congratulations on the purchase of your new TeachLogic® classroom audio system. You can be assured that this product fulfills all specifications and was produced to high quality control standards.

TeachLogic incorporates the latest state of the art technology, employs the most advanced manufacturing methodology and uses only premium quality components to assure many years of reliable performance. We appreciate your confidence by your selection of our product. It is TeachLogic's intent to uphold that confidence by providing factory assistance and reseller support. This manual will help you learn to use and gain the maximum benefit of the system.

**We hope you will take the time to review this manual to familiarize yourself with the product operation and features.**

**TeachLogic, LLC**  
Longmont, Colorado USA  
[www.teachlogic.com](http://www.teachlogic.com)

# Safety Instructions

## Read Instructions

All safety and operation instructions should be read before operating this TeachLogic product.

## Retain Instructions

Safety and operating instructions should be kept for future reference.

## Water & Moisture

This product should not be operated near water.

## Heat Environment

Do not subject this product to excessive heat conditions.

## Power Source

This product must be connected to an AC power source per the voltage input specified and marked on the power supply.

Do not insert any power cable not provided by the manufacturer into the product. Long prongs can penetrate inside electrical components or current charging conductors.

## Certifications



TeachLogic systems are manufactured using lead-free processes and are free of materials harmful to the environment. They conform to European RoHS guidelines for consumer products.

## Power Cord Caution

Power cable should be routed clear of foot traffic and supported clear of kinking or abrasion.

## Object Protection

Locate the operating unit so it will not be subjected to falling objects or water entry. Do not drill hole in or screw objects into the product except as specified by manufacturer.

## Internal Service

User should not attempt to service this product. All internal service must be accomplished by a qualified technician.

## Electric Shock

Do not adapt or modify the AC power plug. Do not remove thus lifting the earth ground connection (3<sup>rd</sup> prong) or use power supply without a connector to a 3-prong grounded outlet.

## CAUTION

**Recycle**—Do not dispose rechargeable batteries in trash. It is unlawful to do so in numerous states. **Go Green.** Save our resources and do not contaminate.

Contact: [Earth911.com](http://Earth911.com)  
1-800-CLEANUP



## System info

---

Date of Purchase

---

Model Number

---

Serial Number

### Notes

---

---

---

---

---

---

---

---

## Contact

If you should encounter an unresolved issue, please contact the TeachLogic customer service department for further assistance.

760-631-7800 | [support@teachlogic.com](mailto:support@teachlogic.com) | [teachlogic.com](http://teachlogic.com)

## Limited warranty

For full warranty details refer to [teachlogic.com/warranty](http://teachlogic.com/warranty).

# Contents

System Overview .....	5
System Diagram .....	6
<b>Installation .....</b>	<b>7</b>
<a href="#">Installation Planning .....</a>	<a href="#">7</a>
<a href="#">Connection of Speakers.....</a>	<a href="#">8-9</a>
<a href="#">Installation of Ceiling Sensor .....</a>	<a href="#">10</a>
<b>Integration .....</b>	<b>11</b>
<a href="#">Computer Anti-Hum .....</a>	<a href="#">11</a>
<a href="#">Video Conferencing Connection .....</a>	<a href="#">12</a>
<b>Configuration .....</b>	<b>13</b>
<a href="#">Final Setup.....</a>	<a href="#">13</a>
<a href="#">Power Button Lights   Standby Function.....</a>	<a href="#">14</a>
<a href="#">Troubleshooting .....</a>	<a href="#">15</a>
<a href="#">System Specifications.....</a>	<a href="#">16</a>

### Front Panel

1. Power Button/ Indicator LED
2. Channel A Microphone Volume Control
3. Channel A Connectivity Indicator LED
4. Channel B Microphone Volume Control
5. Channel B Connectivity Indicator LED
6. DVD Input Volume Control
7. Computer Input Volume Control
8. Aux Input Volume Control
9. Aux Input Port (3.5 mm)
10. Line Output Volume Control
11. Line Output Port (3.5 mm)  
(suitable for Lesson Capture)

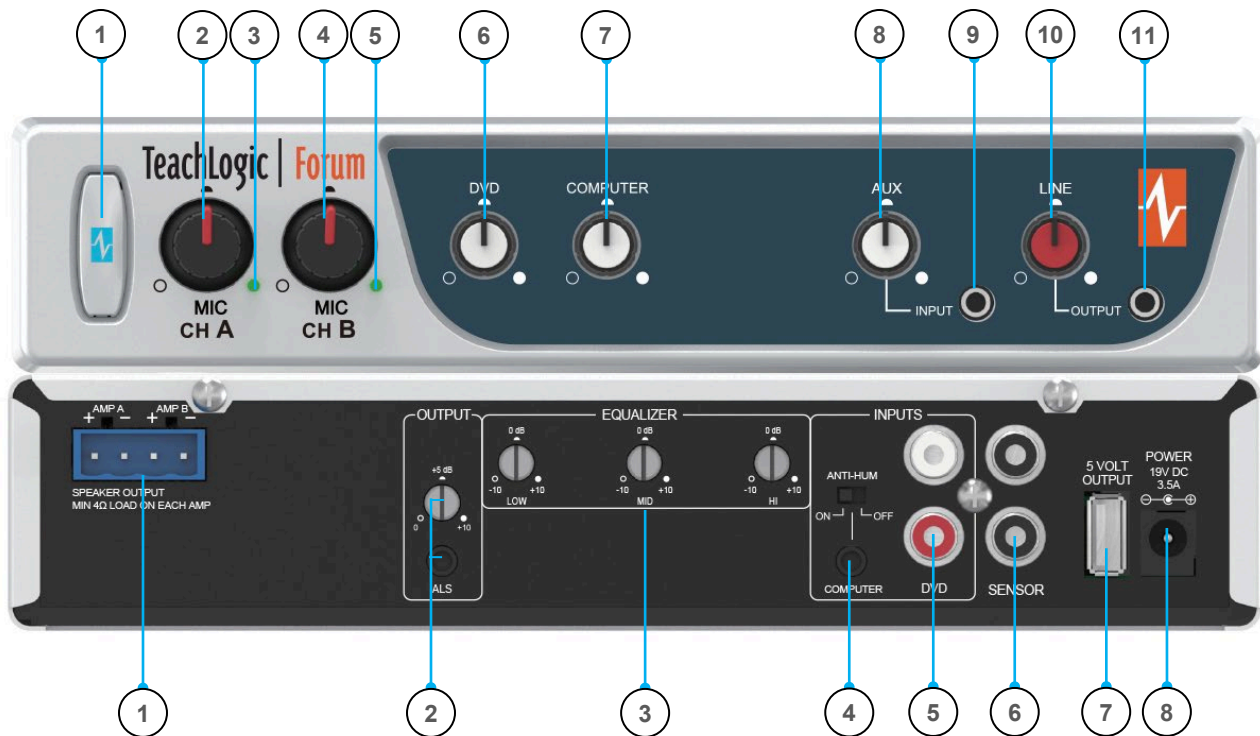

### Back Panel

1. Speaker Output
2. ALS Output (3.5 mm) & Gain Control
3. Three Band Equalizer Controls
4. Computer Input Port (3.5 mm) / Computer Anti-Hum ON/OFF Switch
5. DVD Input Ports (Dual RCA, 0 dB)
6. Powered IR Ceiling Sensor Inputs (RCA x 2)
7. 5 Volt USB Output for chargers
8. Power Input: 19 VDC, 6.5 A

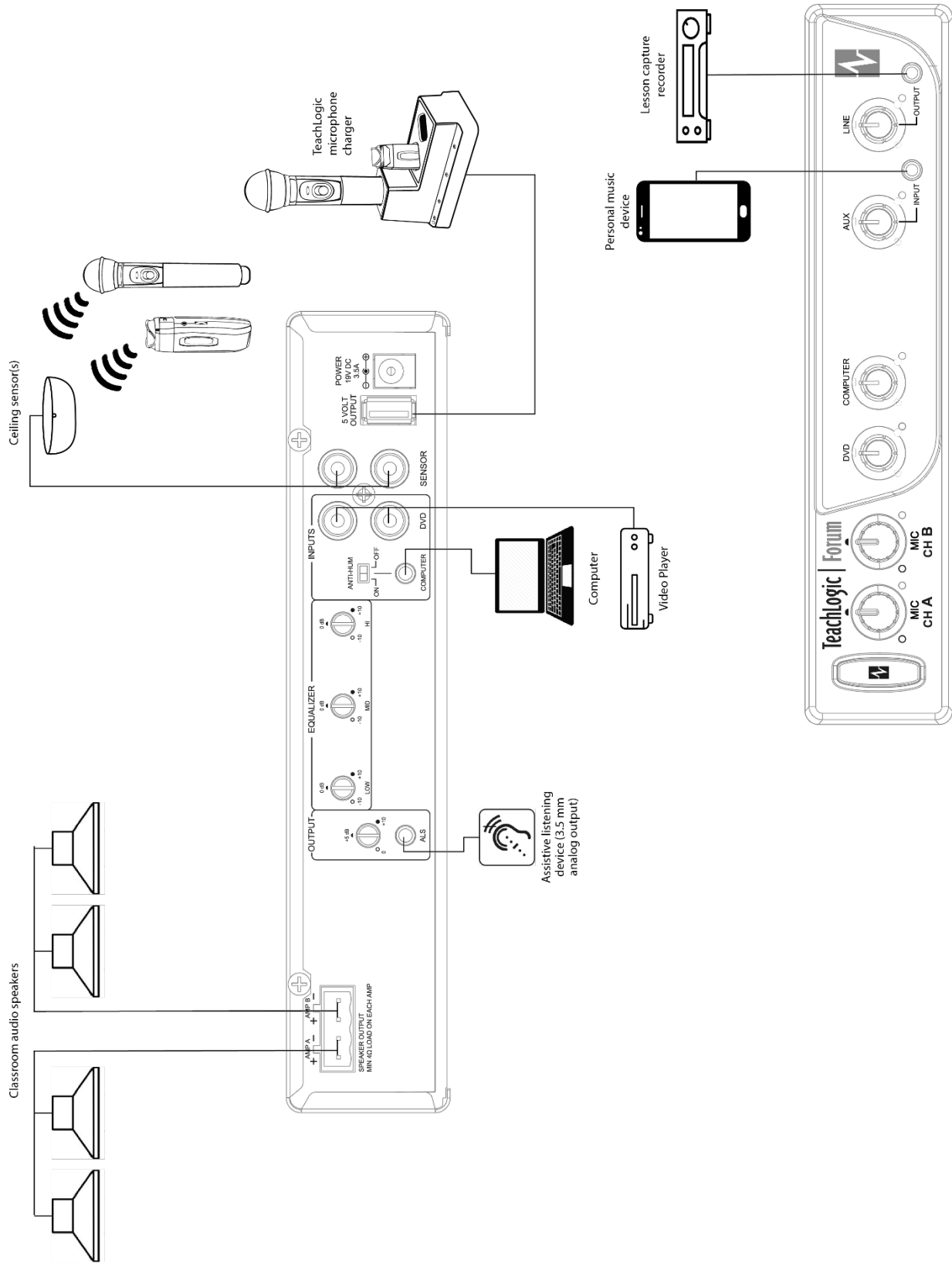

TeachLogic® Forum™ (IMA-240) Wiring Diagram

The goal of a classroom audio system is to evenly distribute sound throughout the listening area.

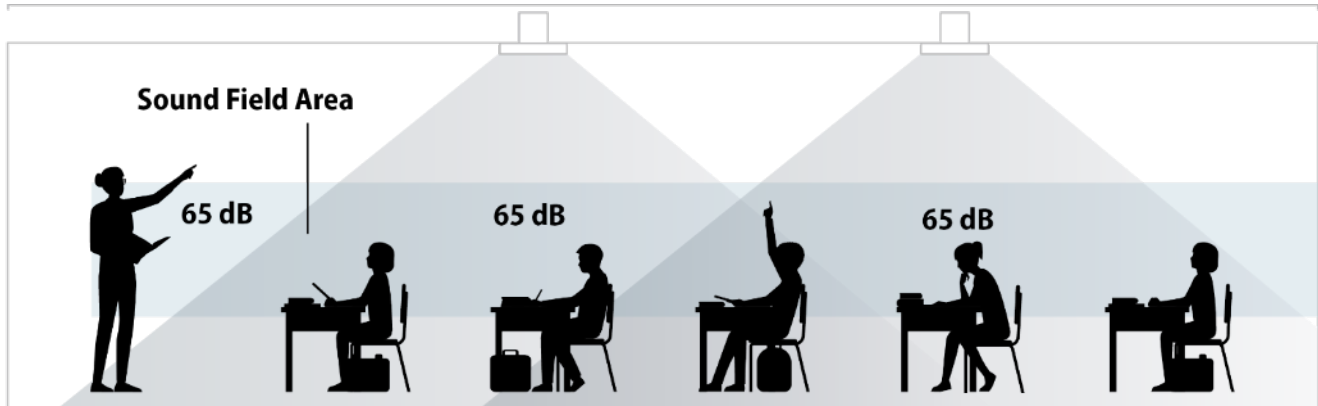

## Component Placement

1. **Amplifier:** Choose location that supports accessibility requirements and wiring constraints for power, speakers, ceiling sensor, and audio devices connecting to the amplifier.
2. **Ceiling Sensor:** Locate in the center of the ceiling; maintain line of sight to teacher locations; keep away from direct sunlight and electrical interference.
3. **Speakers:** The Forum™ can power 4 classroom speakers. Mark location for wall mount vs. ceiling mount and confirm wiring run to the amplifier. Ensure speakers evenly cover the listening area.
4. **Integrations/Connections:** Confirm location of other systems you plan to connect to the amplifier such as audio devices, computer, TV, projector, etc., noting how the wiring needs to run.
5. **Charger:** Confirm microphone charging location for daily use/charging.

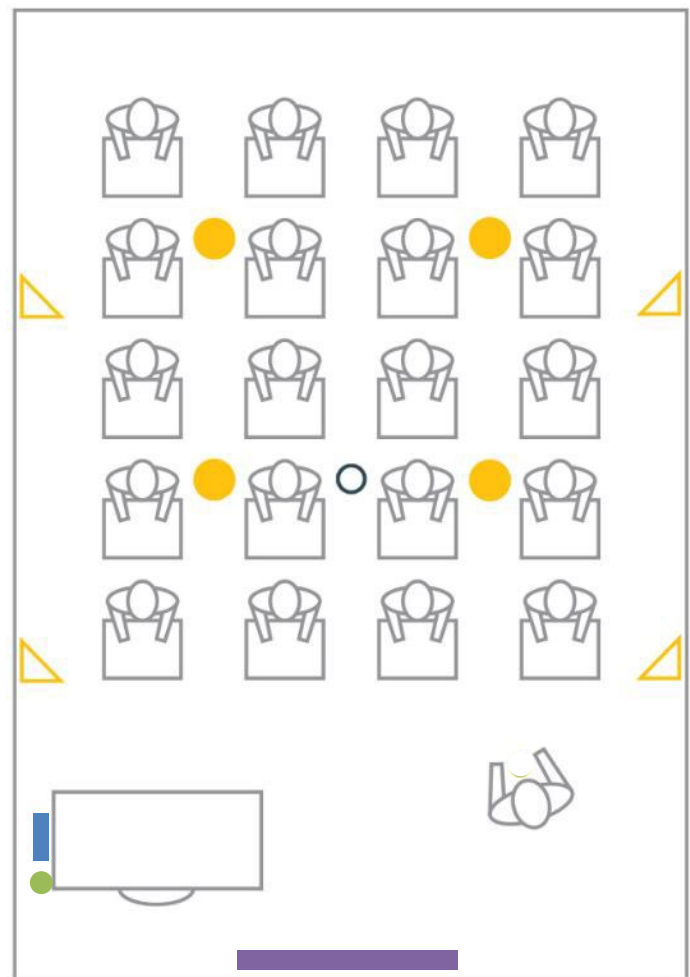

## Speaker Location

Below are examples of room coverage for two and four speaker installations. For more than 4 speakers, space the next row(s) accordingly.

**Ceiling Speakers:** Locate and identify the center most tile in each quadrant.

**Wall Speakers:** First observe the shape of the room: ceiling height, door locations, windows, mounting surface, and seating area. Ordinary installation would be to locate the speakers on each side wall beginning at the front row of listeners, approximately 6–7 feet above the floor.

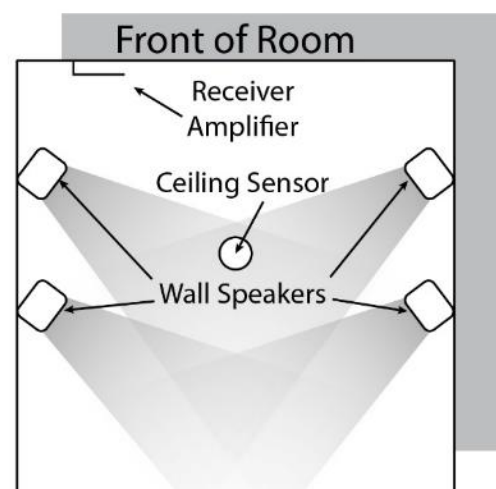
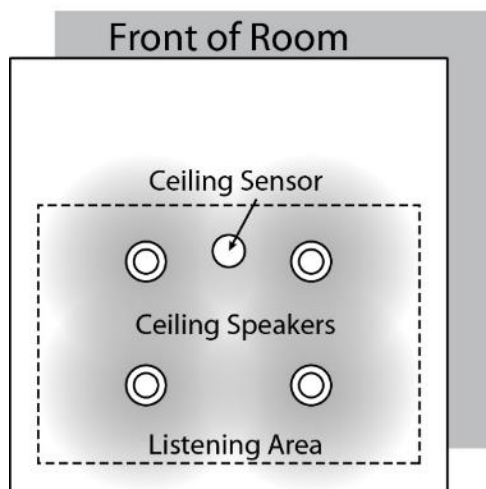
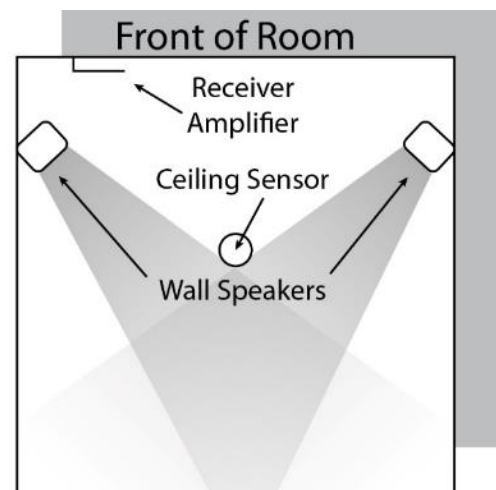
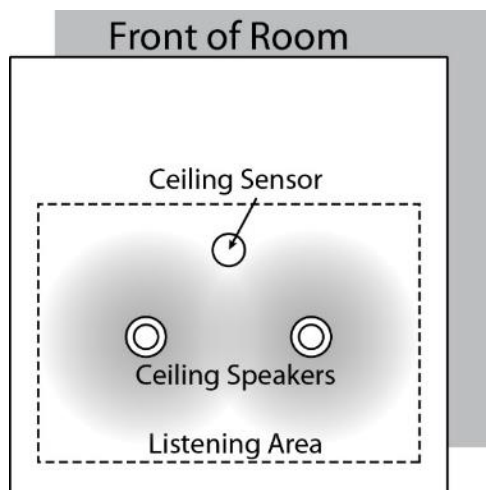

## Connection of speakers

The IMA-240 has two channels of amplified audio, rated for a minimum 4-ohm speaker load (two 8-ohm speakers each, connected in parallel provide 4 ohms impedance).

There is one blue phoenix style speaker connector on the back panel, providing two pairs of speaker terminals.

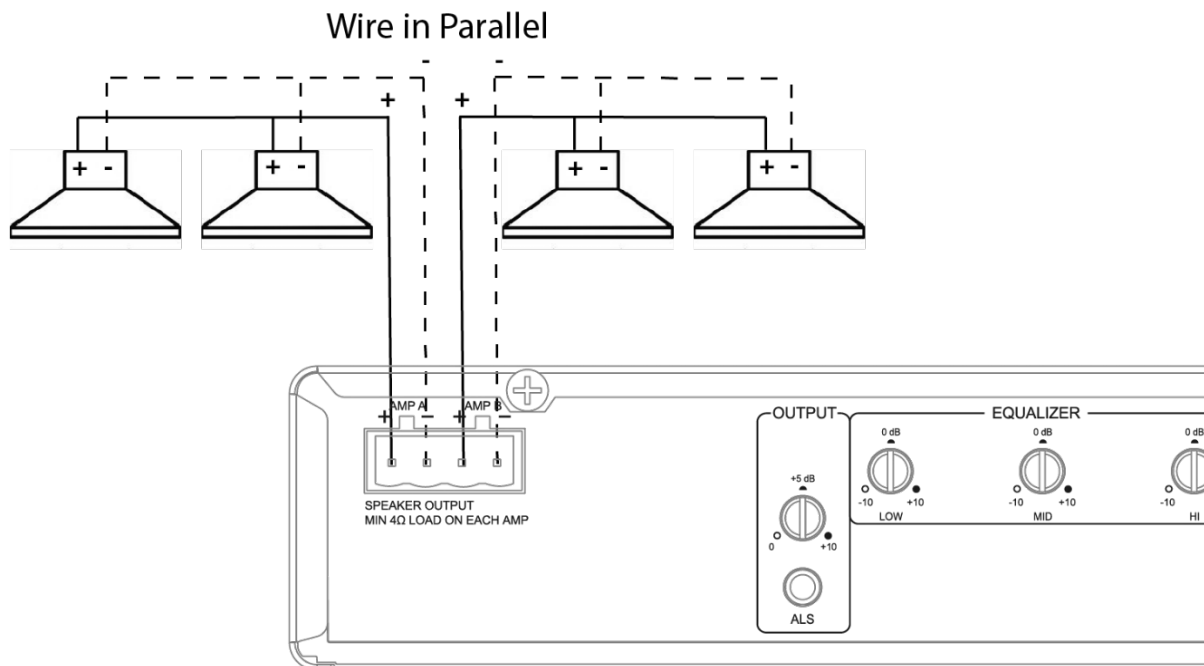

## Installation of Infrared (IR) Ceiling Sensor (ICS-55)

The ideal mounting location is in the center of the room's ceiling. The ideal installation is flush mounted on a white, reflective ceiling like suspended acoustic ceiling tiles. This will ensure 360° coverage and will minimize the transmission distance for more reliable performance.

For additional coverage, or in large rooms, a second IR sensor may be placed on ceiling or a wall and connected to the second sensor input. As many as three sensors may be powered by the amplifier (use a wye adapter for two of them to connect to one input). **The max cable length is 100 ft.**

### Installation 1 – Attach to T-bar rail

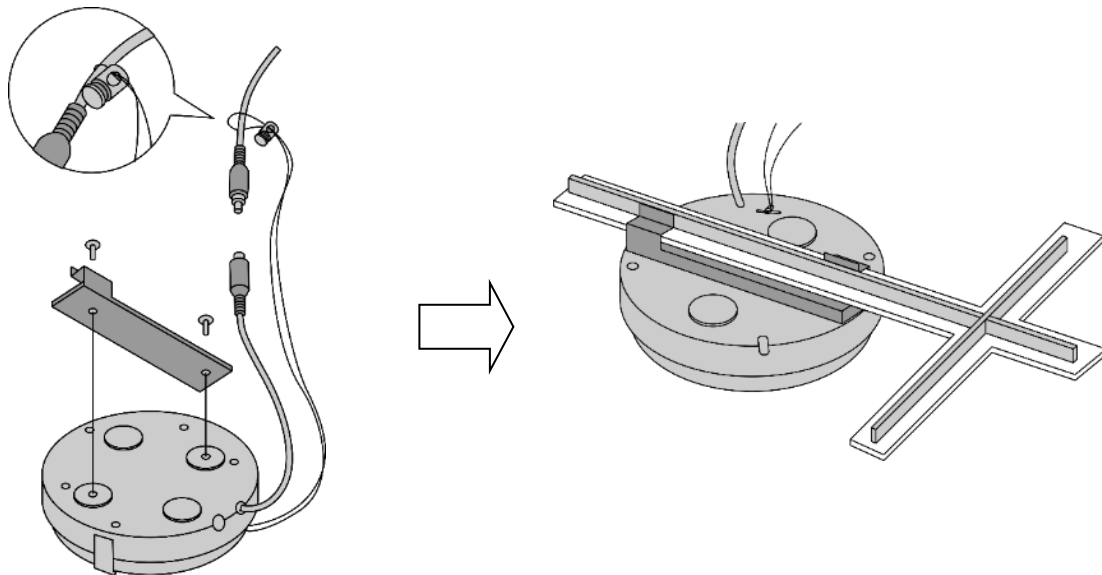

### Installation 2 – Concrete or Drywall Surface

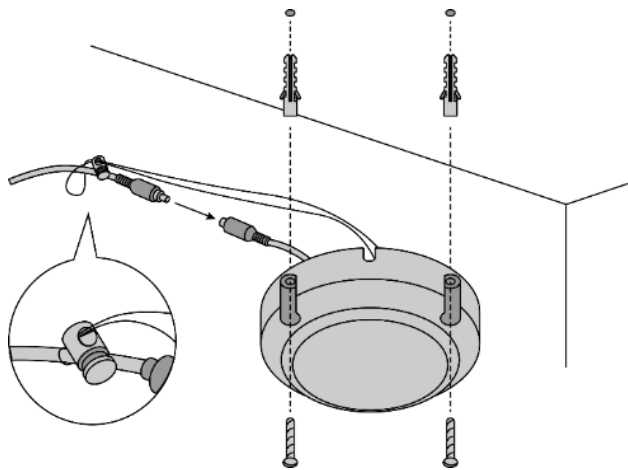

### Installation 3 – Wood Surface

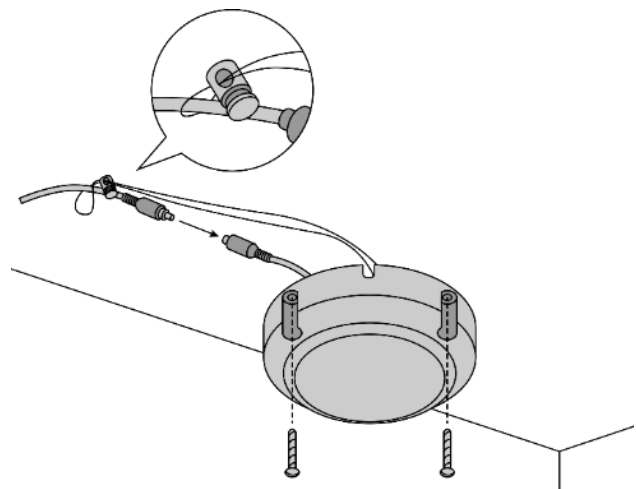

**FINAL STEP:** Route sensor cable to amplifier and plug into one of the amplifier's two sensor inputs. An illuminated green LED will indicate that the sensor is receiving power from the amplifier.

## Anti-Hum Feature

The rear panel input port labeled “Computer” has a switchable feature to eliminate or reduce hum sounds often present when computers are connected to external amplifiers. The hum is known as a ground loop hum and may be present if the computer and amplifier have electrical grounding differences. The telltale characteristic is that it is 60 hertz (a somewhat low tone.) Inside the amplifier is a ground isolating balun that may reduce or eliminate the hum when switched ON. If not needed, it is better to leave switched OFF as the sound quality for the connected device will be slightly better in this case.

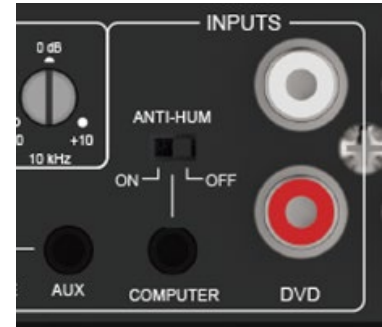

## Video Conferencing Connection

All media devices connected to the TeachLogic amplifier (including microphones) will be heard by online viewers. All audio—including devices connected directly to the computer—will play through the TeachLogic amplifier/receiver in the classroom.

- Amplifier Output > Computer Microphone Input: enables online learners to hear classroom audio including wireless microphones
- Computer Speaker Output > Amplifier Input: enables classroom learners to hear computer & conference audio
- For more detailed instructions, visit <https://teachlogic.com/distance-learning/>.



## Final Setup

Now that the system is installed and connected, turn the system “ON” and test its performance. The testing will be done using an IR (infrared) microphone (Sapphire™ or Handheld) to confirm good connectivity.

### AMPLIFIER

- Connect power supply to amplifier, then plug into outlet.
- Turn the amplifier ON by pushing the power button. The “TL” illuminates solid blue when the amplifier is powered ON.
- Confirm there is power to the IR ceiling sensor: A green LED on edge of sensor should be illuminated that indicates it is receiving power.
- Set all gain/volume dials to mid scale (12 o'clock position)

### IRT-60 (SAPPHIRE) MICROPHONE SETUP

- Confirm "Ch A" volume dial is at mid scale (12 o'clock position)
- Slide gain/volume control switch on Sapphire to "Normal" setting.
- Press and hold power mic button until the LED light illuminates.
- Observe Sapphire power LED. Solid blue indicates power is on and mic is transmitting.
- Observe amplifier Ch A indicator LED. It should be green, indicating a connection between the microphone and ceiling sensor.
- If using two IRT-60 microphones in the same room, one must be changed to channel B to avoid interference. Watch the how-to video on [teachlogic.com/resources](http://teachlogic.com/resources).

#### Note: Next steps should be performed with a second person as the listener

- Stand under or in front of a speaker.
- Hold the microphone with the top at your collarbone and observe the speaker volume in the room by speaking in a natural voice.
- Raise the volume on Ch A until feedback begins, then reduce volume to an acceptable level and until indications of feedback have stopped.
- Walk around the room while talking into microphone to confirm good connectivity and sound levels and lack of feedback under/in front of each speaker.

### IRH-35 HANDHELD MICROPHONE SETUP

- Confirm "Ch B" volume control is set to mid-scale (12 o'clock position)
- Power on microphone using ON/OFF switch.
- Observe LED above mic switch. Solid green indicates power is on and ready to use.
- Observe amplifier Ch B indicator LED. It should be green, indicating a connection between the microphone and IR ceiling sensor.
- Hold the microphone about 3 inches from the mouth, above chin level and perform voice test.
- Raise the volume on “Ch B” until feedback begins, then reduce volume to eliminate all feedback.
- Walk around the room while talking into the microphone to confirm good connectivity and sound under/in front of each speaker without feedback.

**Once complete, charge microphones so they are ready for use.**

## Power Button Operation

The main power button on the amplifier's front panel has multiple indications as shown in the table below.

<b>Red, solid</b>	<b>Off state; power is still supplied to USB port on back panel used to charge microphones</b>
<b>Blue, solid</b>	On
<b>Blue flashing</b>	Page received and audio sources muted
<b>Amber, solid</b>	In Standby (or "Sleep") mode. See below
<b>Red, flashing</b>	Muted by Fire Alarm Mute Input
<b>Purple, flashing</b>	System in Ducked mode with all line inputs lowered in volume to allow microphones to be better heard. The Sapphire mic on Channel A can trigger this "Teacher Priority" mode with a press of its priority button (toggles mode on and off)
<b>Green/Red flashing</b>	Indications of Security Alert pulse mode (see section above)
<b>Green Flashing</b>	Security Alert activated

## System Standby Function

Standby Mode is a feature that reduces power consumption after the amplifier has not been used to amplify audio signal for a period of two hours. After entering the automatic standby mode, the amplifier displays an amber light at power button.

Normal ON mode may be resumed by

1. speaking into a microphone that is on,
2. sending an audio signal into one of the line inputs \*such as a projector or flat panel audio signal), or
3. pressing the power button once.

It may take a few seconds for the normal mode to resume after one of these actions is taken. A page signal can also "wake" the amplifier, but to hear the full first page of a morning, be sure to wake it first with one of the methods above since, or the initial several seconds may be missed if there are no other paging speakers provided to deliver the page audio.

## Troubleshooting

Problem	Solution
<b>System will not power “ON”</b>	<p>Verify AC power; the power button will illuminate Blue when turned ON</p> <p>Check if system has been unplugged; reconnect to power outlet or use another device to ascertain power available at outlet</p> <p>Check circuit breaker</p> <p>Call maintenance for assistance</p>
<p><b>System is turned “ON” but there is no sound</b></p> <p>or</p> <p><b>System is in standby and does not “wake up”</b></p>	<p>Turn “ON” microphone/ transmitter; the “TL” power button will illuminate to solid Blue when turned ON</p> <p>If the power button is illuminated red, the battery is low</p> <p>Ensure the mic is not muted (blinking light on mic indicates it is muted)</p> <p>Ensure gain/volume control knob on amplifier/receiver is turned up to mid-scale (12 o'clock position)</p> <p>On amplifier/receiver, ensure a green LED is illuminated just below Ch A or Ch B knob (depending on the microphone used).</p> <p><b>If no LED is illuminated:</b></p> <ul style="list-style-type: none"> <li>• Check the green LED on the ceiling sensor</li> </ul> <p><b>If sensor LED is not lit:</b></p> <ul style="list-style-type: none"> <li>• Sensor has been disconnected (check cable plug ends), or</li> <li>• Power output to sensor has failed (Sensor or amplifier may need to be replaced)</li> </ul>
<b>Voice is distorted and/or signal drop-out occurs</b>	<p>Verify that the sensor is not being covered</p> <p>Verify there is no obstruction between microphone and sensor</p> <p>Ensure there is no direct sunlight on sensor</p> <p>Ensure no other IR mics in room are turned on</p> <p>If sensor is mounted on a dark surface or without a flush ceiling surface, reception can be hampered.</p>

**Forum™ (IMA-240)**

<b>Amplifier Output Power</b>	50 W RMS, 2 x 25 W channels
<b>Receiver Input</b>	Infrared FM, 2 wireless mic channels
<b>Modulation</b>	Wide-band FM
<b>Reception Frequencies</b>	Ch. A: 2.08 MHz   Ch. B: 2.54 MHz
<b>Deviation</b>	10 kHz Nominal, 25 kHz Maximum
<b>De-emphasis</b>	50 $\mu$ s
<b>Tone Key</b>	32.768 kHz
<b>Infrared Wavelength</b>	850 nm
<b>External Sensor Input</b>	2, RCA, powered ports
<b>Connectivity Coverage</b>	1,600 sq ft per sensor, up to 3 sensors supported
<b>Total Harmonic Distortion</b>	<1% @ 1 kHz
<b>Frequency Response</b>	40 Hz –18 kHz, $\pm$ 3 dB
<b>Line Level Inputs</b>	Rear Panel: DVD input, dual RCA, 0dB Rear Panel: Computer input, 3.5mm, -10 dB Front panel: Auxiliary input, 3.5 mm, -10 dB
<b>Anti-Hum Balun</b>	Present on Computer input
<b>Line Outputs</b>	Front panel: 3.5mm w/ gain control Rear Panel: 3.5 mm w/ +10 dB gain control
<b>Output Impedance</b>	Rated Load: 4 $\Omega$ minimum impedance
<b>Equalization</b>	3-band, $\pm$ 10 dB
<b>S/N Ratio</b>	65 dB
<b>Speaker Connection</b>	4-pin Phoenix Connectors
<b>Charger Output</b>	5 VDC, USB
<b>Power Supply</b>	19 VDC / 3.5 A CE, CSA and UL Listed
<b>Dimensions</b>	8 1/2" W x 1 3/4" H x 7 1/2" D
<b>Weight</b>	1.7 lb.

**Power Supply (AC-36)**

<b>Type</b>	Regulated Switching Power Supply, CE, CSA and UL listed
<b>Input Voltage</b>	100-240 volts AV, 47-63 Hz
<b>Output Voltage</b>	19 VDC, 3.43 A
<b>Power Output</b>	65 watts max

## Sapphire (IRT-60) microphone/transmitter specs

<b>Transmission Carrier</b>	Infrared
<b>Transmission Frequencies</b>	2.08 MHz & 2.54 MHz
<b>Channel Selection</b>	Field Switchable
<b>Transmitting Diodes</b>	Six
<b>Wavelength</b>	850 nm
<b>Modulation</b>	FM Wide-Band
<b>Frequency Response</b>	100 Hz - 10 KHz
<b>Pilotone Frequency</b>	32.768 KHz
<b>Peak Deviation</b>	± 25 KHz
<b>Dynamic Range</b>	95.5 dB @ 2.8% THD
<b>Operating Range</b>	60 Ft. line of sight
<b>Latency (mic to speakers)</b>	0.87 ms
<b>Battery Used</b>	Lithium-ion polymer (3.7V / 620mAh)
<b>Battery Life</b>	8 hr/Charge
<b>External Power Charger</b>	5V DC Micro USB Connector
<b>Transmission Angle</b>	180° Conical
<b>User Controls</b>	
<b>Power (On/Off)</b>	Press & Hold
<b>Mute Switch (On/Off)</b>	Momentary Press (blinks when muted)
<b>Add'l Mic Gain Control</b>	Normal, -3dB, -6dB
<b>Audio Source Vol./Gain</b>	Increase, Decrease
<b>Channel Select</b>	(A or B) in battery compartment
<b>External Mic/Aux Input</b>	3.5 mm Line Level
<b>Dimensions (H x W x D)</b>	3.5" x 1.25" x 0.75"
<b>Weight</b>	1.4 oz including battery

## Handheld (IRT-35) microphone/transmitter specs

<b>Transmission Carrier</b>	Infrared
<b>Transmission Frequencies</b>	2.08 MHz & 2.54 MHz
<b>Channel Selection</b>	Field Switchable
<b>Transmitting Diodes</b>	Ten
<b>Wavelength</b>	850 nm
<b>Modulation</b>	FM Wide-Band
<b>Pilotone Frequency</b>	32.768 KHz
<b>Peak Deviation</b>	± 25 KHz
<b>Operating Range</b>	50 ft. line of sight
<b>Power Switch (Slide)</b>	On/Off
<b>Battery Charge Level (LED)</b>	Green: Full   Orange: Medium   Red: Low
<b>Battery Life</b>	Approx. 7 Hr./Charge
<b>Dimensions</b>	2.125" dia. (Head), 1.4375" dia. (Body), 9.625" H
<b>Weight</b>	10.3 oz. w/ Battery



541 Main St. Longmont, Suite B, CO 80501  
TeachLogic.com | Support@TeachLogic.com | 760-631-7800