

User Guide: OA-50

TeachLogic's Ovation Amplifier/ Mixer/ Receiver (OA-50) uses special DECT (Digital Enhanced Cordless Telecommunications) radio technology to wirelessly receive audio, making it perfect for any size or type of classroom. With four inputs, two outputs, and two mic channel receivers, the OA-50 can integrate various media devices and simultaneously use two wireless microphones to supplement your presentation material for added student engagement.

DIAGRAM 1: Main System Controls

Front Panel

- | | |
|---|--|
| <ol style="list-style-type: none"> 1. Power Button Logo Indicator Light 2. MIC A Microphone Volume Control 3. MIC A Pairing Button and Indicator Light 4. MIC B Microphone Volume Control 5. MIC B Pairing Button and Indicator Light 6. DVD Input Volume Control | <ol style="list-style-type: none"> 7. Computer Input Volume Control 8. Aux Input Volume Control 9. Video Conference Input Volume Control 10. Video Conference Input Port (3.5 mm)
(Also suitable for Aux audio source) 11. Video Conference Output Volume Control 12. Video Conference Output Port (3.5 mm)
(Also suitable for Lesson Capture) |
|---|--|

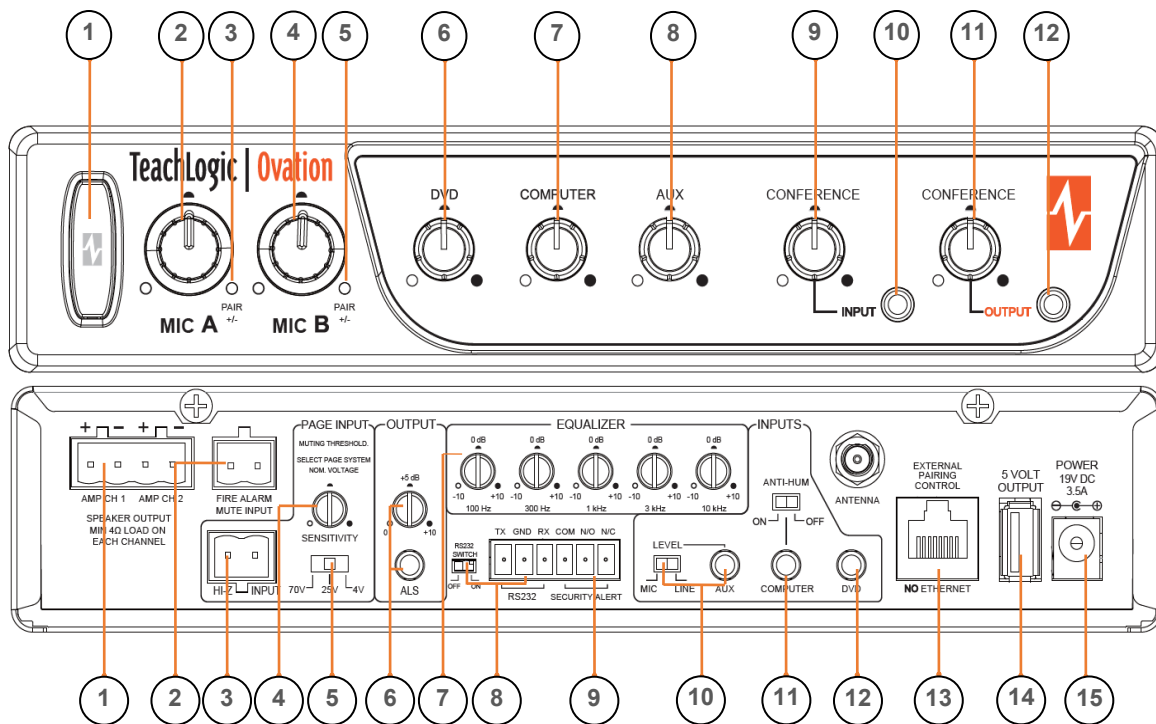

Back Panel

- | | |
|--|--|
| <ol style="list-style-type: none"> 1. Speaker Output 2. Fire Alarm Mute Input 3. Page Input 4. Page Sensitivity Control 5. Page Input Voltage Selector 6. ALS Output (3.5 mm) & Gain Control 7. Five Band Equalizer Controls 8. RS-232 Input & OFF/ON Switch | <ol style="list-style-type: none"> 9. Security Alert Interface 10. Aux Input Port (3.5 mm) & Mic/Line Level Selector; Mic: -40dB/Line: -10dB 11. Computer Input Port (3.5 mm) / Computer Anti-Hum ON/OFF Switch 12. DVD Input Port (3.5 mm) 13. External Pairing Control for OP-10 Wall Mount Control Panel 14. 5 Volt USB Output for Chargers 15. Power Input: 19 Vdc, 3.5 A |
|--|--|

DIAGRAM 2: Side Switches

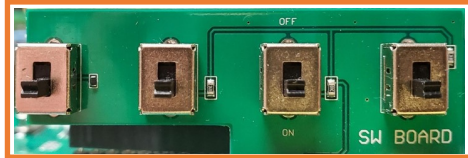

↑
SWITCHES ON LEFT
SIDE OF DEVICE

VISIBLE BEHIND
VENTILATION GRILL

	LEFT SWITCH	CENTER-LEFT	CENTER-RIGHT	RIGHT SWITCH
POSITION	ANTENNA	SECURITY ALERT # OF PULSES	PAGING PASS THROUGH TO SPEAKERS	CONFERENCE ECHO GUARD
UP	EXTERNAL	1	OFF	ON
DOWN	INTERNAL	4	ON	OFF

DIAGRAM 3: OP-10 Buttons

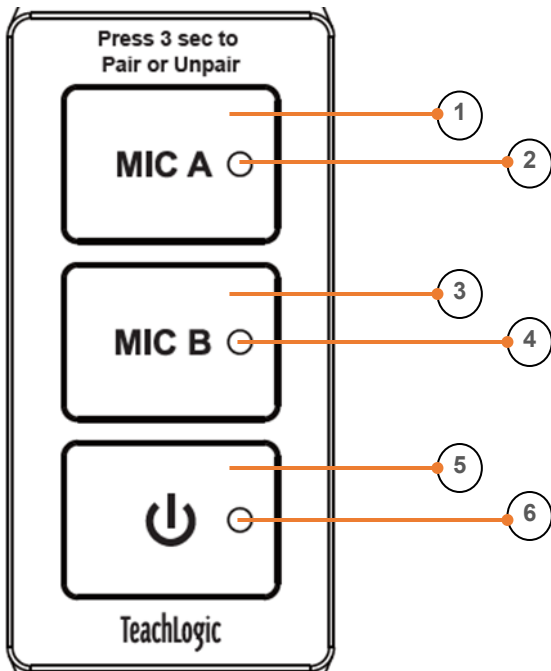

1. MIC A Pairing Button
2. MIC A Pairing Indicator Light
3. MIC B Pairing Button
4. MIC B Pairing Indicator Light
5. OA-50 Power Button
6. Power Status Indicator Light

DIAGRAM 4: Speaker Wiring

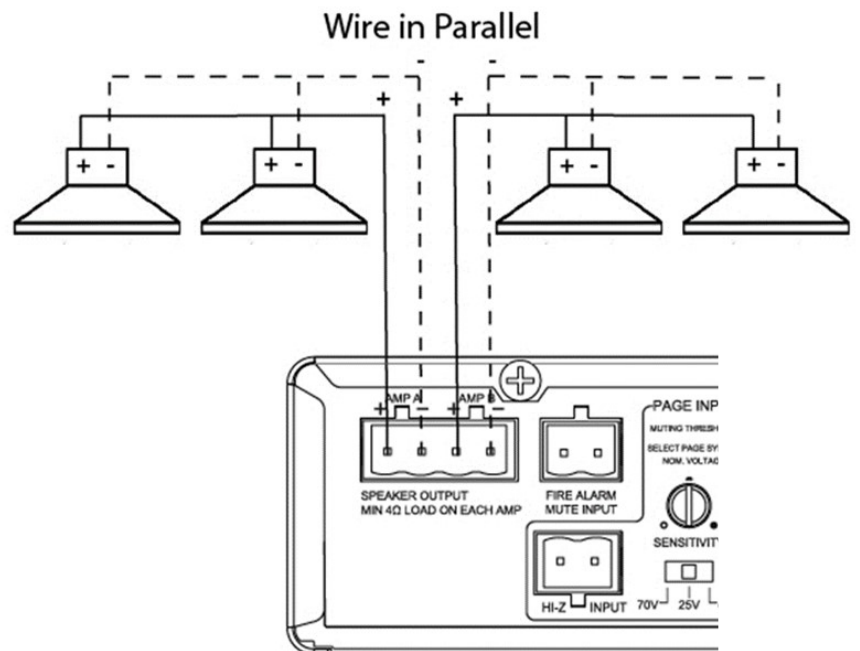

TABLE 1: OA-50 Power Button Indicator Lights

The main power (logo) button on the amplifier’s front panel has multiple indications as shown in the table below.

Red Solid	Off Note that power is still supplied to USB port on back panel.
Red Blinking	Muted by Fire Alarm Mute Input
Blue Solid	On
Blue Blinking	Page detected and audio sources muted
Blue Slow Blinking	In Standby (or “Sleep”) mode. See “Standby Mode” below
Purple Solid	In Talkover mode. All line inputs are lowered in volume (“ducked”) to allow microphones to be better heard. “Talkover” mode can be triggered by pressing the spring switch on the left side of the OM-10 pendant mic.
Yellow Blinking (3x)	Radio (RIB) reset. Requires 6 sec power button press (when blue) to reset. Note that both pair lights (pictured in Diagram 1 as #3 and #5 on the front panel) will also flash green 3x.
Green Blinking	Security Alert activated. Also indicates whether in Security Alert 1- or 4- pulse mode (see “Security Alert” section below).

TABLE 2: OA-50 Power (Logo) Button Controls

Tap	Off → On Standby → On On → Off
Double Tap	On → Standby
Press and Hold 6s	On → Radio Reset

Initial Setup

Powering your OA-50 On and Off

- To power your OA-50, you must first connect the external power supply cable to the power input (labeled “POWER 19V DC 3.5A”) on the back of your OA-50. Then plug the power supply’s cord into a 110Vac wall outlet.
- Once plugged in, your OA-50’s power/ logo button light will illuminate red or blue indicating power is being received. Red indicates Off, and blue indicates On. It will be in whichever state it was in when last powered.
- If off (red), turn it on by tapping the logo button once. The button light will turn blue.
- To turn off your OA-50, tap the logo button once more, and the light will turn back to red.
- You may also manually put the OA-50 into standby mode by double pressing the logo button. You can do this from a blue light “On” state.

Connecting Loudspeakers to your TeachLogic System

- On the back panel of your OA-50 (#1 in Diagram 1 above), there is a 4-pin blue terminal block connector used for loudspeaker connection. The OA-50 can power 4 classroom speakers.
- There are two loudspeaker (amplified audio) channels, each rated for a minimum 4-ohm speaker load (two 8-ohm speakers each, connected in parallel provide 4 ohms impedance). See Diagram 4: Speaker Wiring above.

Pairing a Mic to your OA-50 - MIC A or MIC B

- ◇ **What is Pairing?** Since the TeachLogic DECT microphones are compatible with any OA-50, and there may be many of both products in your building, it is important to associate your mic to the specific OA-50 in your classroom. This associating is called “pairing”. To pair your OM-10 pendant mic or OM-20 handheld mic with your OA-50, you will need to tell your mic to communicate with your specific receiver and not another down the hallway.
- ◇ **Choosing the right channel:** On your OA-50, there are two channels to which you can pair your microphone; select either A or B. Usually, the teacher microphone will be paired as MIC A while the student mic will be paired as MIC B.
- **To pair, both mic and receiver (OA-50) will need to be in pairing mode. To do this, refer to *Diagram 1* and the below instructions.**
Note: In this example, we will be pairing an OM-10 with an OA-50. For instructions on how to pair with an OM-20 see the OM-20 user guide.
 - 1) Press the spring switch on the left side of your mic and the logo button at the same time and hold both for 3 seconds.
 - This will initiate the pairing mode for your microphone, and it will begin to fast-flash green. It will stay in this pairing mode for 1 minute or until paired.
 - 2) During this time, press and hold the pairing button on the OA-50 next to the MIC channel you want to pair with (or on the OP-10 wall panel if installed) for 3 seconds.
 - This pairing button will illuminate and start fast-flashing green indicating it has entered the pairing mode. It will stay in this pairing mode for 1 minute.
 - 3) While both units are in pairing mode, they will find each other and become paired. Once the pairing has been established, the mic logo button will turn solid blue and the OA-50 pairing button will change to solid green. Your mic is now paired and connected, ready to be used with your TeachLogic system.

Pairing vs Connecting

- Pairing your mic and receiver creates a sustained link between the two. Your mic and OA-50 will each remember its pairing even after being turned off and on. The act of pairing does not need to be repeated each time you use your mic. Each mic and receiver channel is paired to at most one other device.
- Connecting is when data transmits between the two paired devices. When connected, the two devices are communicating with each other allowing audio to be passed through and heard. If already paired, your mic will automatically connect to your OA-50 each time they are both on.
- This automatic connecting will continue until either device has terminated the pairing.

Un-pairing your OA-50

- You may wish to un-pair your receiver from your mic if you want to stop using your mic with your receiver. There are two methods.
 - 1) To un-pair your mic from your OA-50, press the pairing button next to the channel you wish to un-pair and hold for 3 seconds. Ideally, perform this un-pairing when the mic and OA-50 are both on.
 - 2) Alternatively, you can use the microphone to un-pair the two devices. To un-pair using the mic, press and hold for 3 seconds the same two buttons used to pair (the spring switch on the left side of your mic and the logo button in the center of your mic).
- The channel pairing indicator light on the OA-50 will turn off, and the logo button light on your mic will turn yellow indicating they are no longer paired. Transmission of audio will stop on that channel.

Using your OA-50

Using your Audio Inputs

- The OA-50 has 4 audio inputs to integrate various media devices so you can supplement your presentation material for added engagement. These 4 input channels can all be used simultaneously with your microphone; they include: DVD, Computer, Auxiliary, and Conference.
- Each input channel is appropriate for “line level” inputs from a variety of devices. The DVD input is calibrated for a slightly higher-level input signal. Inputs may be stereophonic or monophonic, and will be converted to monophonic in the OA-50.



I. DVD Input

- Pictured in Diagram 1 as #12 on the back panel, the 3.5mm DVD input is frequently used with fixed video displays and mobile TV carts. You can control the volume by turning the DVD volume knob (#6 on the front panel of Diagram 1) clockwise (“CW”) to increase or counterclockwise (“CCW”) to decrease the volume of the audio on this input channel.

II. Computer Input

- On the back panel (#11 on Diagram 1) is the Computer input where you can use a 3.5mm stereo audio jack to connect your computer output to your OA-50. To increase or decrease the volume of your Computer audio, you can turn the Computer volume knob (#7 on the front panel of Diagram 1) CW to increase or CCW to decrease the channel’s volume.
- The Computer input has a switchable feature called “Anti-Hum” to eliminate or reduce 60 Hz “ground loop” hum sounds often present when computers are connected to external amplifiers.
Note: If this feature is not needed, it is better to leave the switch in the “OFF” position as the sound quality for the connected device will be slightly better in the “OFF” position.

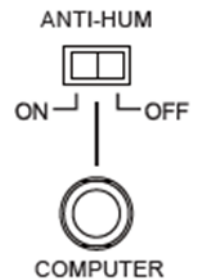

III. Auxiliary Input

- On the back panel (#10 on Diagram 1) is the Auxiliary channel for your OA-50. This 3.5mm port is commonly used to connect sound sources such as a video displays or cell phones with a line level audio output. You can turn the AUX volume knob (#8 on Diagram 1) CW to increase or CCW to decrease the input volume.
- The Auxiliary Input has a switchable feature called “Level” where you can choose between “MIC” or “LINE”. If using a wired “dynamic” microphone in this input, it is best to select “MIC” and for all other audio sources, one should select “LINE” because “LINE” signals are higher level signals.
Note: Connecting a line-level source to this input if set to MIC level will cause distortion and excess loudness from your speakers. On the other hand, connecting a mic-level source to a LINE level input will result in little to no sound as the mic signal is too weak for the line level setting. For these reasons, it is important to ensure you select the correct level when using this channel.

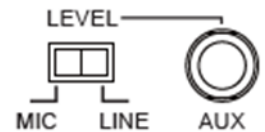

IV. Conference Input

- Shown as #10 on the front panel of Diagram 1, the Conference Input is used to ensure all students hear equally well regardless of their location. This input uses a 3.5mm stereo audio jack to connect a device hosting an audio or video conference (such as a computer using *Zoom*, *Teams*, or a flat panel video display using *Hangouts*). Connect the computer/display audio output to the Conference Input on the OA-50 to share all audio from distance learners, including devices connected directly to their computer, and to play this audio through the TeachLogic OA-50 speakers in the classroom.
- The Conference Input’s volume control knob is located directly to the left of the input (#9 on the front panel of Diagram 1). Like the other knobs, turn it CW to increase or CCW to decrease the input volume.
- The Conference Input may have the “Echo Guard” feature switched On or Off. The Conference Output mixes various input channels, including any device’s audio plugged into the Conference Input. When both the Conference Input and Conference Output are being used simultaneously, the Echo Guard should be switched to On. This will prevent the Conference Input channel’s audio from creating an echo on the Conference Output channel. The Echo Guard otherwise does not need to be On when Conferencing Output is not being used.

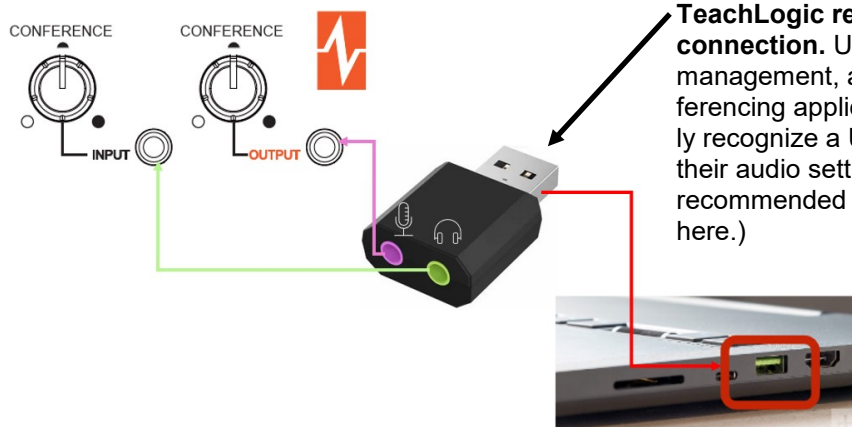

TeachLogic recommends a USB connection. USB simplifies cable management, and most video conferencing applications automatically recognize a USB connection in their audio settings menu. (See recommended adapter shown here.)

Using your Audio Outputs

- The OA-50 has 2 audio outputs that ensure distance learning students as well as students with hearing impairments can hear their instructor and the audio material available to other students in the classroom.
 - Conference Output
 - Shown as #12 on the front panel of Diagram 1, a 3.5mm stereo audio jack can be used to deliver audio to conference participants. The audio can come from wireless microphones in the classroom as well as from all other media devices connected to the TeachLogic OA-50.
 - The Conference Output's volume control knob is located directly to the left of the Conference Output (#11 on the front panel of Diagram 1). Turn the knob CW to increase or CCW to decrease the output volume.
Note: For further instruction on how to set up your Conference Input and Output for distance learning, follow this link: <https://tinyurl.com/52xjh3z8>
 - Assistive Listening System (ALS) Output
 - This output is generally used with an Assistive Listening System already set up in your classroom. By connecting a 3.5mm jack from the output on the back of your OA-50 to your ALS, students with hearing loss can directly receive sound via their personal receiver from anything that the TeachLogic system amplifies.
 - The ALS Output can also be directly connected to a student's personal transmitter via a 3.5mm jack cable if needed.
 - The ALS Output audio will include a mix of all the audio inputs on the OA-50, including the audio received on the Page Input. Thus, a student listening on an ALS device will hear pages if they are routed to the OA-50 loudspeakers (see below "Page Pass Through").
- Equalizer Controls
 - Five knobs along the top of the OA-50 (#7 on the back panel in Diagram 1) are controls for the equalizer. Use these controls to increase or decrease the different spectral parts of audio output to ensure audio quality is at its best.
 - Normally these controls are set in their 0 dB positions as shown.

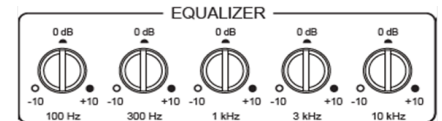
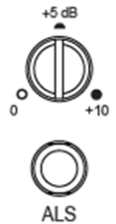

Using your 5 Volt Output

- A USB-A port on the OA-50 (#14 on the back panel in Diagram 1) provides a 5Vdc power output. This output can be used to charge your microphone with a single cable. It can also power an OC-20 Charging Station to charge multiple mics at one time.
- This power port should not be used with non-TeachLogic devices which may require too much power and may overload the port.

Resetting your OA-50

- If your OA-50 is not pairing as expected, you can manually reset the radio by pressing and holding the logo button (#1 on the front panel in Diagram 1) for 6 seconds. Or you can press and hold the OP-10 power button. The OA-50 logo button will blink purple 3x, briefly power off, then power back on to the solid blue state. This should remedy any radio error state that may have occurred.

Standby Mode

- Standby Mode is a feature that reduces power consumption after the OA-50 has not been used to amplify audio signal for a period of two hours. After entering the automatic standby mode, the OA-50 power button displays a slow blinking blue light.
 - Normal "On" mode may be resumed by:
 - Powering on a TeachLogic Ovation microphone that is paired with your OA-50.
 - Sending an audio signal into one of the line inputs of the OA-50 from a connected source such as a computer or flat panel audio signal.
 - Pressing the power button on your OA-50 once (or on your OP-10).
- Note:** It may take a few seconds for the normal On mode to resume after one of these actions is taken. A page signal can also "wake" the amplifier, but to hear the full first page of the morning, be sure to wake the OA-50 first with one of the methods above because the initial seconds of a page may be missed as the amplifier is waking up (if there are no other paging speakers provided to deliver the page audio).

External and Internal Antennae

- Your OA-50 comes with one internal and one external secondary antenna. A switch on the side of the OA-50 allows you to select between the two. These antennae receive signals from the Ovation wireless microphones or from other transmitters. In medium to large sized rooms, the external antenna should be selected and connected as instructed below.
- You can attach the supplied external antenna directly to the back panel of your OA-50 by screwing it onto the gold threaded connector (SMA type) on the back panel. An extension cable for the antenna may also be used for remote antenna location. You may optimize reception quality by adjusting the orientation and/ or location of the antenna. Higher non-blocked locations are best.
Note: When threading your external antenna onto the gold threaded connector, be sure the knurled portion is only finger tightened. To change the orientation of the antenna, hold the knurled portion and rotate the antenna via the slip joint.
- After installing your external antenna, position the switch on the left side of your OA-50 in the "UP" position (far left switch in Diagram 2). You can also find this switch position diagram on the bottom of your OA-50.
Note: Ensure you use a non-metallic object such as a toothpick to manipulate the switch.

RS-232 Control and Switch

- There is a 6-pin green terminal block connector with 3 contacts labeled *RS232* (#8 on the back panel of Diagram 1) that provide a connection for a third-party RS232 control device to be used with the OA-50.
- There is a switch labeled *RS232 SWITCH OFF / ON* directly to the left of the green terminal block connector. When using a RS232 control device, ensure the RS232 switch is in the ON position. This will direct the OA-50 to take commands from the panel. If you are not using a control panel, switch to the OFF position.
- The RS232 command list is available from TeachLogic
Note: When the RS232 switch is set in the ON position, front panel volume controls on the OA-50 are defeated and will not work.

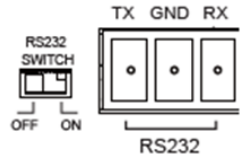

Fire Alarm Mute Input

- The 2-pin orange terminal block connector labeled *Fire Alarm Mute Input* (#2 on back panel in Diagram 1) provides a connection to mute the OA-50. If a connected fire alarm system is in alarm mode, this will mute all audio in the OA-50 amplifier. This feature will help lower the overall sound level to allow students and staff hear the audible fire alarm tones and instructions within the classroom.
Note: The Page Pass Through audio is muted during alarm.
- Audio will resume at original volume 11 seconds after fire alarm input stops receiving a signal. The signal is a dry contact closure.
Note: This feature only works if your school connects their fire alarm system to the OA-50.



Security Alert Activation and Settings

- The Security Alert feature allows a user with a TeachLogic wireless pendant microphone to summon help or alert administration personnel to an urgent situation in the room of that user. This feature uses wire from the school's paging or security system (such as a wall-mounted call button panel) to connect to the OA-50 receiver via the 2 or 3 contacts on the 6-pin terminal block connector (#9 on the back panel of Diagram 1).
- To activate the security alert (your OM-10 pendant microphone must be on and connected to your OA-50), push and hold the OM-10's AUDIO spring switch for 5 seconds. The OM-10 main (logo) button will flash green 3x once an alert is activated. Your OA-50 logo button will do the same.
Note: The OA-50 will function normally during the alert, i.e., there is no change the volume or to audio input/output. The system will not produce any sound besides a quiet clicking noise (1 or 4 times) from the OA-50 itself.
- There are two security alert pulse modes, 1-pulse or 4-pulse, as required for different security systems. You can switch between the two settings via the slide switch on the left side of your OA-50 (center left switch on Diagram 2) or the bottom of your OA-50 for the setting instructions.
Note: Ensure you use a non-metallic object to manipulate the switch.

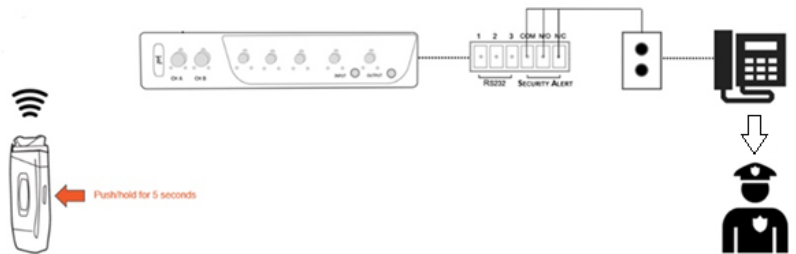

Page Mute vs Page Pass Through

- Page Pass Through is a feature that passes an audio paging signal through the amplifier and to the connected loudspeakers.
- Page Mute will mute any audio signal passing through the OA-50 (except for a page signal) whenever a page is detected on the separate paging system.
- Page Pass Through may be switched on or off by moving a side panel switch up or down center right switch in Diagram 2). This switch position guide is also located on the bottom of your OA-50.
- Page Mute is controlled by a sensitivity dial (#4 on the back panel of Diagram 1) and by a switch set to the Nominal voltage level of the paging system (#5 on the back panel in Diagram 1).
- The impedance of the page system input port (2-pin green terminal block connector) is >50,000 ohms.

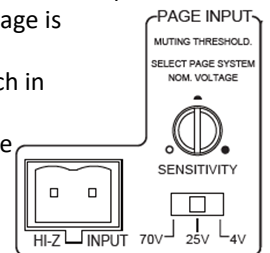

Using the OP-10 Control Panel

- If your OA-50 needs to be placed in an area or compartment that is not easily accessed by the user, an OP-10 Wall Mount Control Panel can be used to allow limited remote controls. These include pairing and un-pairing microphones from an OA-50, turning an OA-50 On and Off, putting the OA-50 into or out of Standby Mode, and radio-resetting the OA-50. Please refer to Diagram 3 in conjunction with the instructions below.
- Lights on the OP-10 indicate pairing and connection status by duplicating certain illuminations of the front panel pairing indicators on the OA-50 (#3 & #5 on the front panel in Diagram 1).
- The indicator light next to the OP-10 power button mimics that on the OA-50 logo button showing solid blue (On), slow-blinking blue (Standby), no light (Off), and blinking blue (Radio Reset).
Note: If radio (RIB) reset is occurring all three LED indicator lights (#4, #5, and #6 on Diagram 3) will blink 3x.
- Pressing an OP-10 pair button has the same effect as pressing a pair button on the OA-50.
- Pressing the power button on the OP-10 has the same effect as pressing the logo button on the OA-50.

FCC compliance statement:

Contains Transmitter Module FCC ID: Y82-DA14AVD / IC ID: 9576A-DA14AVD

This device complies with Part 15 of the FCC Rules.

Operation is subject to the following two conditions: (1) this device may not cause harmful interference, and (2) this device must accept any interference received, including interference that may cause undesired operation of the device.

Changes or modifications to the equipment not expressly approved by the Party responsible for compliance could void the user's authority to operate the equipment.

Note: This equipment has been tested and found to comply with the limits for a Class B digital device, pursuant to part 15 of the FCC Rules. These limits are designed to provide reasonable protection against harmful interference in a residential installation. This equipment generates, uses and can radiate radio frequency energy and, if not installed and used in accordance with the instructions, may cause harmful interference to radio communications. However, there is no guarantee that interference will not occur in a particular installation. If this equipment does cause harmful interference to radio or television reception, which can be determined by turning the equipment off and on, the user is encouraged to try to correct the interference by one or more of the following measures:

- Reorient or relocate the receiving antenna.
- Increase the separation between the equipment and receiver.
- Connect the equipment into an outlet on a circuit different from that to which the receiver is connected.
- Consult the dealer or an experienced radio/TV technician for help.
- Privacy of communications may not be ensured when using this device.

