

READ AND SAVE THESE INSTRUCTIONS

P/N 35010033-B



COMPACT HAZER PRO™
user manual



Dimensions/Legal

All dimensions are in millimeters

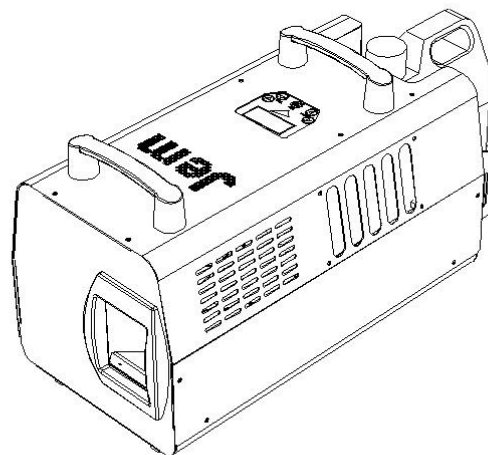
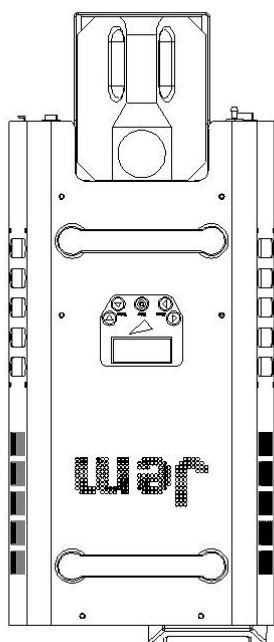
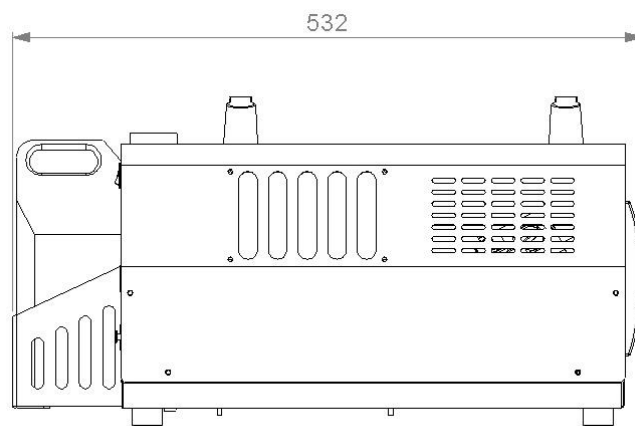
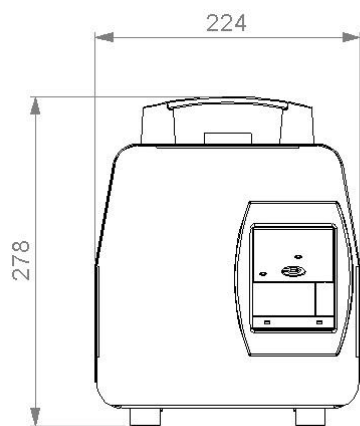

Information subject to change without notice. HARMAN Professional Denmark ApS disclaims liability for any injury, damage, direct or indirect loss, consequential or economic loss or any other loss occasioned by the use of, inability to use or reliance on the information contained in this document.

©2016 HARMAN Professional Denmark ApS. All rights reserved. Martin® and JEM™ are registered trademarks of HARMAN Professional Denmark ApS registered in the United States and/or other countries. Features, specifications, and appearance are subject to change without notice.

HARMAN Professional Denmark ApS • Olof Palmes Allé 18 • 8200 Aarhus N • Denmark

www.martin.com

Document Revision - B

Contents

Dimensions/Legal	2
Contents	3
Safety information.....	4
Product overview	7
Product description	7
Features at a glance	7
Product details	8
Quick Start	9
Setting up	9
Making haze.....	9
Switching off.....	9
Installation and setting up.....	10
Location.....	10
AC power	10
Setting up.....	11
Final checks	11
Turning on the power	11
Turning off the power	11
Control settings.....	12
Overview	12
Setting Run mode	12
Setting Haze density	12
Setting Fan speed.....	12
Setting the Timer.....	13
Setting the DMX start address	13
Setting the master-client link mode.....	13
Alt option	14
Priming the machine after fluid out	14
Resetting options to factory settings.....	14
Optional Digital Remote control.....	16
Overview	16
Functions.....	16
Connection	16
DMX control	17
Overview	17
Connection	17
DMX functions.....	17
Approved Haze fluids.....	19
Basic service.....	20
Cleaning	20
Martin Pro-Clean and Storage Fluid	20
Fuse replacement	21
Troubleshooting	22
Status messages	23
Resetting the machine after fluid out	23
Technical Specifications	24
Notes	28

Safety information

The following symbols are used to identify important safety information:



Caution! Safety hazard. Risk of personal injury.



Caution! Burn hazard. Hot surface. Do not touch.

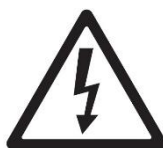

Danger! Hazardous voltage. Contact will cause electric shock.



Caution! Fire hazard.



Warning! This product is not for household use. It presents risks of injury due to electric shock, burns, falls and respiratory problems!

Read this manual before operating the machine, follow the safety precautions listed below, and observe all warnings in this manual and printed on the machine. Use the machine only as described in this manual and in accordance with local laws and regulations.

If you have questions about how to operate the machine safely, or if you have followed the instructions in this manual and the machine is malfunctioning, please contact Martin Service and Support.

Preventing electric shocks



- Always ground (earth) the machine electrically.
- Use only a source of AC power that complies with local building and electrical codes, and that has both overload and ground-fault protection.
- Before connecting the machine to power, check that the voltage indicated on the machine's serial label matches your local AC power voltage. If your AC power voltage does not match, do not use the machine. Contact Martin Service and Support for assistance.
- Before using the machine, check that all power distribution equipment and cables are in perfect condition and rated for the current requirements of all connected devices.
- If the machine or any cables connected to it are in any way damaged, defective, wet, or show signs of overheating, stop using the machine and contact Martin Service and Support for assistance. If the supply cord is damaged, it must be replaced by a special cord or assembly available from the manufacturer or its service agent.
- Disconnect the machine from AC power before servicing and when not in use.
- This machine is not waterproof and should not be exposed to wet outdoor conditions. Do not immerse in water or any other liquid. Do not expose to high-pressure water jets.
- Do not spill fluid over or inside the machine. If fluid is spilled, disconnect AC power and clean with a damp cloth. If fluid is spilled onto electronic parts, take the machine out of service and contact Martin Service and Support for advice.

- Do not remove the covers or attempt to repair a faulty machine. Refer any service not described in this manual to Martin Service and Support.
- Do not operate the machine if any parts are damaged, defective or missing.
- Moisture and electricity do not mix. Do not aim haze output at electrical connections or devices.

Preventing burns and fire



- The haze produced by the machine is hot enough to cause burns when it leaves the nozzle, and very hot droplets of fluid escape occasionally. Keep people and objects at least 600 mm (24 in.) away from the haze output nozzle.
- Do not touch the haze output nozzle during or after use – it becomes extremely hot and remains hot for several hours after the machine has been shut down.
- Haze output contains glycol, a flammable alcohol that burns with an almost invisible blue flame. Do not point haze output at sources of ignition such as open flames or pyrotechnic effects.
- Do not attempt to bypass thermostatic switches, fluid sensors or fuses.
- Replace fuses only with ones of the type and rating specified in this manual for the machine.
- Provide a minimum free space of 100 mm (4 in.) around the machine.
- Provide a minimum free space of 500 mm (20 in.) around fans and air vents and ensure free and unobstructed airflow to and around the machine.
- Keep the machine at least 600 mm (24 in.) away from combustible and heat-sensitive materials.
- Do not operate the machine if the ambient temperature (T_a) is below 5° C (41° F) or above 40° C (104° F).
- Do not operate the machine if the relative air humidity exceeds 80%.

Preventing injuries

- Ensure that the surface on which the machine is located or installed can safely hold the weight of the machine.
- Fasten the machine securely to a fixed surface or structure when in use. The machine is not portable when installed.
- If suspending from a rigging structure ensure that any supporting structure and/or hardware used can hold at least 10 times the weight of all the devices they support.
- If suspending from a rigging structure, fasten the machine to a rigging clamp. Do not use safety cables as the primary means of support.
- If the machine is installed in a location where it may cause injury or damage if it falls, install as directed in this manual a secondary attachment such as a safety cable that will hold the machine if a primary attachment fails. The secondary attachment must be approved by an official body such as TÜV as a safety attachment for the weight that it secures, must comply with EN 60598-2-17 Section 17.6.6 and must be capable of bearing a static suspended load that is ten times the weight of the machine and all installed accessories.
- Check that all external covers and rigging hardware are securely fastened.
- Block access below the work area and work from a stable platform whenever installing, servicing or moving the machine.

- Do not install the machine over areas where people are present.
- Do not operate the machine with missing or damaged covers or shields.
- In the event of an operating problem, stop using the machine immediately and disconnect it from power. Do not attempt to use a machine that is obviously damaged.
- Do not modify the machine in any way not described in this manual or install other than genuine Martin parts.
- Refer any service operation not described in this manual to a qualified technician.
- Haze output can cause condensation. Do not point the output at smooth floors. Floors and surfaces may become slippery. Check these frequently and wipe dry as necessary to avoid any danger of slipping.
- Ensure at least 2 m (6.6 ft.) visibility in areas where haze is being produced.
- Haze fluid contains food-grade glycols in solution that may present health risks.

IF SWALLOWED: Do not induce vomiting. Drink 1-2 glasses of water and seek medical attention.

AVOID CONTACT WITH SKIN AND EYES: In case of accidental contact: **EYES:** Hold eyes open and flush with water for ten minutes, seek medical attention if irritation persists. **SKIN:** Remove contaminated clothing and rinse skin for 20 minutes, seek medical attention if irritation persists.

Consult the fluids' SDS for more detailed safety information at <http://www.martin.com/safety-documents>

- This machine is not intended for use by persons (including children) with reduced physical sensory or mental capabilities, or lack of experience and knowledge, unless they have been given supervision or instruction concerning use of the machine by a person responsible for their safety. Children should be supervised to ensure that they do not play with the machine.

Preventing breathing problems



- A haze machine can operate safely only with the haze fluid it is designed for. Use the machine only with fluids specified under "Approved Haze fluids" on page 19 or you may cause the release of toxic gases, presenting a severe health hazard. You will also probably damage the machine.
- Do not create dense haze in confined or poorly ventilated areas.
- Do not expose people with health problems (including allergic and/or respiratory conditions such as asthma) to haze output.
- Do not point haze output directly at a person's face or at face height.

For the latest user documentation and other information for this and all Martin products, please visit the Martin website at <http://www.martin.com>
If you have any questions about how to install, operate or service the fixture safely, please contact your Martin distributor, dealer or contact Martin Service and Support.

Product overview

Product description

The JEM Compact Hazer Pro is a versatile haze machine from Martin Professional designed for the highly demanding professional market. Its ability to produce exceptionally fine atmospheric haze in a short period of time makes it an ideal choice for rental houses, shows, theatres, TV studios, clubs, bars, cruise ships, theme parks and more.

Robust yet small and lightweight, the JEM Compact Hazer Pro is capable of dispersing an even, continuous haze with superior optical clarity and reflectivity, the perfect small-particle haze for highlighting today's highly defined light beams. A high-quality air pump system ensures smooth distribution while a unique mixing channel allows the haze to optimize before being expelled.

Congratulations on your purchase of the JEM Compact Hazer Pro from Martin. Details of the full range of Martin products are available on our website at www.martin.com

Features at a glance

- Continuous Effect Output.
- Sealed fluid system with quick-connect fittings
- User-friendly on board digital control panel.
- Independent variable haze and fan control.
- Water-based fluid provides dense particles and even haze.
- 2.5 l fluid reservoir - 20 hours on full output.
- Optical Density Timer Control system.
- Advanced Pump Technology (APT)
- Optional flying kit, air director and digital remote control.
- Small footprint - lightweight, less than 25 lb. filled.
- Optional Flying Kit, Air Director and Digital Remote Control



***Use only JEM C-Plus Haze Fluid. Use of other fluid will void warranty.
Shutdown switch must be used when turning off to prevent clogging.***

Product details

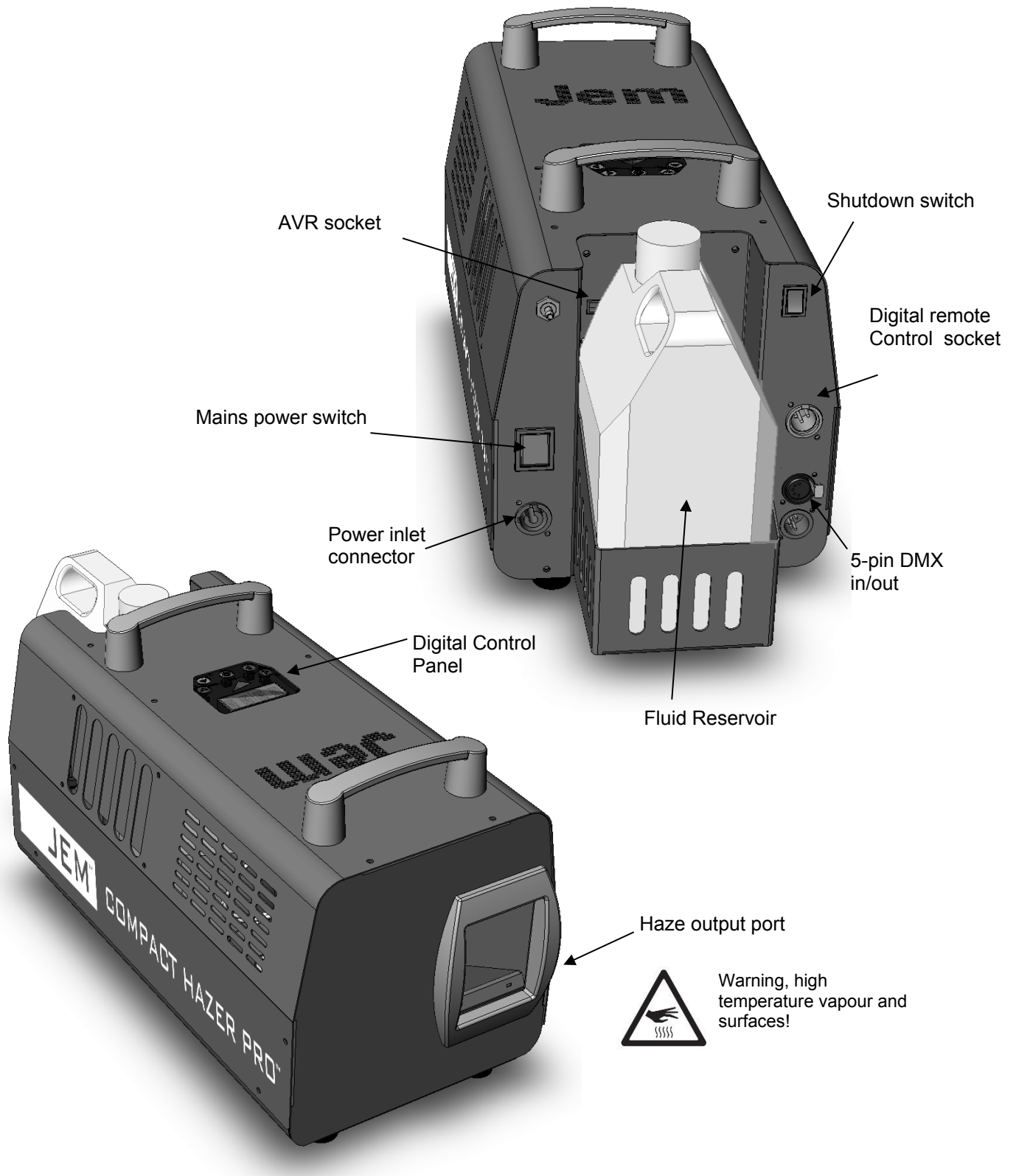

Quick Start

You are no doubt eager to switch on the machine and try it out by making a lot of haze. This section tells you how to do that. However, please also make the time to read the safety and servicing instructions in the remainder of this manual.

Setting up

Locate the machine in a suitably large area with nothing in front of the haze output.

Fill the fluid reservoir with JEM C-Plus Haze Fluid only. Use of other fluid will void the warranty.

Connect a suitably rated power supply to the machine using the supplied mains cable. The power requirements are:

4.4 A @ 230 V (EU model)

8.68 A @ 120 V (US model)

Now set the mains switch, at the rear of the machine, to the 'ON' position. Select **STBY** from the **RUN** menu. The display will show **HEAT**, then after about 1 minute the display will show **RDY** and the machine is ready to produce haze.

Making haze

Press the Menu < > buttons until the display shows **RUN**, then press the Value Up/Down buttons to select **CONT** (continuous). Press Enter.

If there is no haze output or you want to change the haze density, press the Menu < > buttons until the display shows **HAZE**, then press the Enter button and check that the **HAZE** setting is above 0%. If not, use the Value up/down buttons to select a value above 0%.

You can also adjust the fan speed using the **FAN** menu.



If no haze is produced it may be necessary to prime the machine, press the Menu <> buttons until the display shows PRME, then press the Value Up button so the display shows Y, then press the Enter button.

Switching off

The Compact Hazer is designed to run a self-cleaning cycle before power down to help prevent blockages. Before disconnecting the power, you should start the cleaning cycle by pressing the 'Shutdown Switch' on the rear of the unit above the DMX connectors. The red LED in the shutdown switch will light if a cleaning cycle is needed.

If cleaning is needed, the display will show "WAIT", then "WT44" counting down to "WT00". When the display shows "OFF" the power may be turned off.



Do not turn off the power without using the Shutdown switch. This will cause the unit to enter a cleaning cycle when next switched on, and over time will lead to blockages and malfunction of the unit.

Installation and setting up



DANGER! DO NOT operate the haze machine until you have read and observed all the precautions listed under “Safety information” on page 4.

Location

The JEM Compact Hazer Pro is designed to be located on the floor or may be suspended using the optional flying bracket. If suspending the machine, a hanging bracket (optionally available from Martin) should be attached to the machine’s flying bracket with an M12 bolt and nyloc nut.

The machine can operate in any orientation from 30° upwards to 30° downwards. Steeper tilting may cause fluid leakage.

If the machine is to be suspended, ensure the mounting surface can support the weight of the machine. Do not suspend the machine over areas where people will be underneath. Use only the correct Martin flying bracket to suspend the machine.

Ensure that there is at least 100mm clearance all round the machine and at least 60cm in front of the haze output.

AC power

Before using the machine, ensure that a grounding-type (earthed) power plug that fits the local power outlets is installed on the mains power cable provided.



DANGER! Make sure the power plug is correctly rated:

- For EU (230 V) use fit a plug rated 10 A minimum
- For US (120 V) use fit a plug rated 10 A minimum

When installing the plug, follow the plug manufacturer’s instructions and connect pins as follows:

Yellow and green wire to ground (earth), blue wire to neutral and brown wire to live.

The table below shows some common pin identification schemes.

wire	function	marking	screw colour
brown	live	“L”	yellow or brass
blue	neutral	“N”	silver
green/yellow	earth		green

Before connecting the haze machine to power, verify that the AC supply is adequately dimensioned for the current draw of the machine. The machine requires:

- 4.4 A @ 230 V (EU model)
- 8.68 A @ 120V (US model)

Check that the local AC voltage is appropriate, as indicated on the machine's serial number label. If your AC voltage is outside the appropriate range, do not use the machine. Contact Martin Service for assistance.

Setting up

Fill the fluid tank only with JEM C-Plus Haze Fluid (see page 19).

If DMX control is being used, connect the machine using DMX cable (see page 17). If the JEM Digital Remote Control (optional accessory) is being used connect the remote to the Remote socket (see page 16).

Final checks

Before applying power to the haze machine, verify the following:

- the machine is safely located or installed and meets the location requirements stated on page 10
- the operator is familiar with, and able to comply with, the requirements for safe operation listed on page 4.
- the haze fluid is one of the genuine Martin fluids listed under "Approved Haze fluid" on page 19.
- the machine is electrically grounded (earthed)
- the AC power distribution circuits and lines are adequately rated for the current load

Turning on the power

Turn on the main power switch located next to the power inlet. Select **STBY** from the **RUN** menu. The display will show **HEAT**, then after about 60 seconds the display will show **RDY** and the machine is ready to produce haze.

Turning off the power

The JEM Compact Hazer is designed to run a self-cleaning cycle before power down to help prevent blockages. The cycle takes 45 seconds. **Before disconnecting the power** you should start the cleaning cycle by pressing the Shutdown Switch on the rear of the unit above the DMX connectors. The red LED in the shutdown switch will be lit if a cleaning cycle is needed.

If a cleaning cycle is needed, the display will show "**WAIT**", then "**WT44**" counting down to "**WT00**". During this time the unit purges the fluid from its internal pipework to help prevent blockages.

When the display shows "**OFF**" the power may be turned off.



Do not turn off the power without using the Shutdown switch. This will cause the unit to enter a cleaning cycle when next switched on, and over time will lead to blockages and malfunction of the unit.

The cleaning cycle on power up is shown on the display as **WT44**" counting down to "**WT00**", as for the shutdown cycle. Once the display reaches "**WT00**", normal operation of the unit will start.

Control settings

Overview

The **digital control panel** in the center of the top panel allows you to configure the machine using option menus.

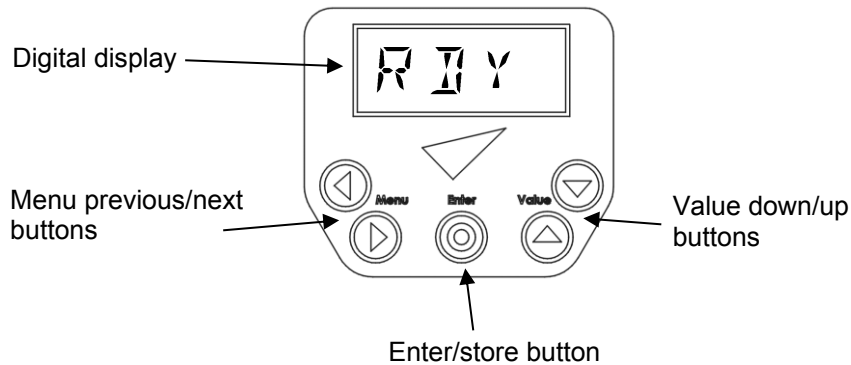

The machine is factory set so the lower of the 'Value down/up' buttons increases a setting. It is possible to change this. Prior to powering the machine up simply press and hold the button you wish to use to increase a setting and press the main power button. Once the display comes on you have successfully configured your preference. The machine will store this setting until the above procedure is performed again.

Setting Run mode

The Run mode sets the operational mode of the unit, either Off, Standby (heaters remain on), Fan only, Timer mode or Continuous mode.

Use the Menu Previous / Next buttons to select the **RUN** option.
Use the Up/Down buttons to select **OFF**, **STBY**, **FAN**, **TIME**, **CONT**.
Press the Enter button to store the setting. The display shows **SET**.

Selecting OFF will cause the machine to begin its cleaning cycle ready for power off, if cleaning is required. This is the same as pressing the Shutdown button on the rear.

Setting Haze density

Use the Menu Previous / Next buttons to select the **HAZE** option.
Use the Up/Down buttons to select the density from **0%** – **100%**.
Press the Enter button to store the haze setting. The display shows **SET**.



If you want to temporarily change the haze density, do not press Enter. The haze setting will go back to its stored value next time the machine is powered up. This applies to all options.

Setting Fan speed

Use the Previous / Next buttons to select the **FAN** option.

Use the Up/Down buttons to select the fan speed from 0% – 100%.
Press the Enter button to store the fan setting.

The fan will run continuously if set above 0% and the RUN menu is set to FAN, TIME or CONT.

If haze is being produced and the fan is off or set to a low speed, the fan speed will be automatically increased to prevent build-up of haze at the machine output.

Setting the Timer

The timer can be operated in two different modes.

Mode 1

Cycle mode

Select the Time option from the Run menu.

The TRUN and TOFF values are set in seconds and are in the range 1-90 and 20-89 respectively. The haze and fan values are taken from the menu settings for Haze and Fan. The timer will cycle continuously until the run menu is changed.

Use this mode for maintaining a low level of haze in smaller venues.

Mode 2

ODTC (Optical Density Timer Control system) mode

Select the Time option from the Run menu.

The TRUN value is set in minutes and is in the range 1-90. The TOFF value should be scrolled to max, at which point the display will show ODT.

During the initial TRUN period the haze and fan values are both set to maximum. When the TRUN period expires the haze and fan values are taken from the menu settings for Haze and Fan. The timer will cycle once only, and will end by displaying ODT as the TOFF value.

Use this mode for rapidly filling a large venue, then dropping back to a level suited to maintaining the haze density in the venue.



When the timer is running and the display is not showing a menu, the display shows TRUN or TOFF as the timer cycles between run and off modes.

Setting the DMX start address

Use the Previous / Next buttons to select the $\overline{P} \overline{N} \overline{X}$ option.

Use the Up/Down buttons to set the DMX start address from 001 to 512. If you hold down the button the address will count up or down.

Press the Enter button to store the address setting.

The machine will automatically respond to a DMX controller whenever it is connected.

When using in a DMX system ensure the LINK menu is set to RECV to avoid causing DMX errors to other devices on the system.

Setting the master-client link mode

It is possible to control several machines from one. The primary machine, which from commands are, is the Master. The other machines are Clients. The machines are interconnected with DMX cabling.

Use the Previous / Next buttons to select the **L I N K** option.
 Use the Up/Down buttons to select **R E C V** (client unit) or **S E N I** (master unit).
 Press the Enter button to store the link setting.

The machine should be set to **S E N I** only if it is running as a master. If running as a client, stand-alone or DMX controlled it should be set to **R E C V**.

Alt option

This option is not currently used and has no effect on the machine.

Priming the machine after fluid out

If the machine runs out of fluid it should be shut down to prevent damage to the pump. To suck the new fluid back into the machine, replace/refill the fluid reservoir and use the prime function.

Use the Previous / Next buttons to select the **P R M E** option.
 Use the Up/Down buttons to change the option to **Y**.
 Press the Enter button to start the priming function.

The machine will pump at full power for about 10 seconds or until the unit senses fluid in the heat exchanger.
 To exit this menu if you decide not to activate the Prime function, select **N** and press Enter.

If the machine is not up to operating temperature the Prime function will do nothing.

Resetting options to factory settings

The factory settings configure a standard mode of operation for the machine.

Use the Previous / Next buttons to select the **R S E T** option.
 Use the Up/Down buttons to change the option to **Y**.
 Press the Enter button to reset all options.

To exit this menu if you decide not to reset the options, select **N** and press Enter.

The factory settings are:

option	setting
HAZE	30%
FAN	30%
TRUN	20 seconds
TOFF	20 seconds
RUN	STBY
ADDR	001
LINK	RECV
ALT	00
PRME	N

Optional Digital Remote control

Overview

The JEM digital remote control, optionally available, may be used for remote control of the JEM Compact Hazer Pro. Several machines may be controlled from one remote using the LINK function (see page 13).

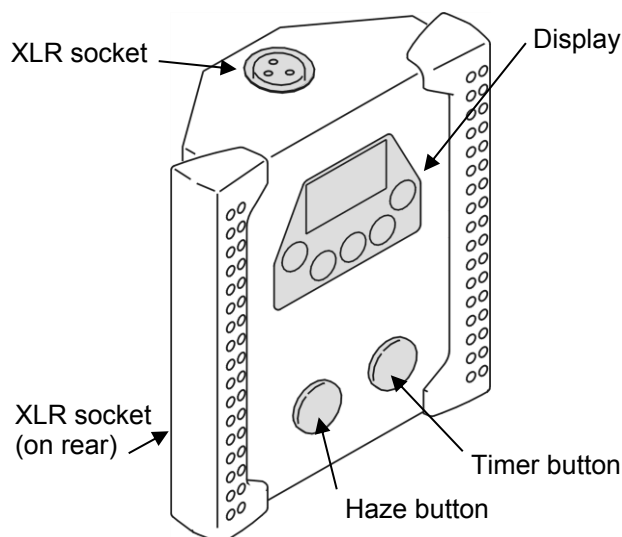

Functions

The remote control provides the following functions:

- Haze button: turns haze output on and off. Press once to start haze and again to stop.
- Timer button: turns the haze timer on and off.
- Haze level setting (HAZE = 0 -100%)
- Fan speed setting (FAN = 0 -100%)
- Timer run time/off time settings (TRUN = 1 -90 seconds, TOFF = 20-89 seconds)
- Run mode (RUN = OFF, STBY, FAN, TIME, CONT)

The functions are the same as on the built in control panel and are described on page 13.

The **RUN** menu duplicates the functions of the Haze and Timer buttons. The buttons are simply a quick way to control this menu function.

Connection

The remote control has two identical XLR sockets on the top and back for connection to the JEM Compact Hazer Pro. Plug the cable provided with the remote control into one of these sockets and into the 3-pin XLR socket on the rear panel of the JEM Compact Hazer Pro.

The remote control is powered through its cable by the JEM Compact Hazer Pro; no batteries are required.

The cable may be extended to up to 25 m (82 ft.) with a 3-pin XLR DMX cable.

DMX control

Overview

DMX is a digital control system widely used in entertainment and architectural lighting. Any controller meeting the DMX-512A standard may be used to control and program the haze output of the JEM Compact Hazer Pro.



When a DMX signal is present, the JEM Compact Hazer Pro stand-alone functions do not work. To fire the unit from the control panel or remote control, the DMX controller must be powered off or disconnected.

Connection

The JEM Compact Hazer Pro provides 5-pin XLR sockets on the rear panel of the unit for DMX connection.

For best results, use cable designed for high-speed digital data transmission.

DMX functions

The JEM Compact Hazer Pro start address must match the DMX start address allocated to it on your controller. To set the address, see "Setting the DMX start address" on page 13. The JEM Compact Hazer Pro requires 3 DMX channels.

For example if the JEM Compact Hazer Pro is set to DMX address 100, channel 1 will be controlled by address 100, channel 2 will be controlled by address 101 and channel 3 by address 102.

When the machine is at running temperature and is under DMX control it displays *DMX*.

The functions of each DMX control channel are shown on the following page.

Channel 1	DMX value range	Function	Macro description	Default value
Haze output Level	0-19	Idle range	None	0
	20-29	Haze 5%		
	30-39	Haze 10%		
		
	210 -255	Haze 100%		
Channel 2	DMX value range	Function	Macro description	Default value
Fan output level (fan will always run if haze is active)	0-19	Idle range	None	0
	20-29	Fan 5%		
	30-39	Fan 10%		
		
	210 -255	Fan 100%		
Channel 3	DMX value range	Function	Macro description	Default value
Special functions	0-50	Idle range	None	0
	51-100	Prime	5 seconds within range to activate once	
	101-150	Auto Fan mode	None (level triggered)	
	151-200	Heater off & shutdown	5 seconds within range to activate once	
	201-255	Heater on (normal operation)	None, but heaters will stay on if channel 3 returns to zero	

Note that when the heaters are on, Channel 3 can stay at level 0 without affecting the operation of the machine. This means that Channel 3 need only go to 100% once at the start of a show, then it can assume a default of zero without the heaters turning off, thus ensuring that the machine is ready when the show runs again. To turn the heaters off, use the Heater Off macro.

Approved Haze fluids

The JEM Compact Hazer Pro must only be used with **JEM C-Plus Haze Fluid**. Martin supplies high quality haze fluids that are based on ultra-pure deionized water. No other fluid is suitable for use.

JEM C-Plus Haze Fluid is a water-based haze fluid formula that is specifically designed for use in the JEM Hazer Pro and JEM Compact Hazer Pro. JEM C-Plus Haze Fluid is a dense molecular formula that produces very fine haze particles, specially designed to emphasize beam and mid-air light effects, projections and lasers. The fluid produces an evenly dispersed atmospheric haze for optimal visual clarity while maintaining a peak refraction index. Besides delivering a unique effect C-Plus Haze Fluid is formulated to generate a long hang time. JEM C-Plus Haze Fluid is very economical and yields a low level of consumption ideal for the precision of performance based art in clubs, theatres and touring applications.

Available in 2.5, 5, 25, and 220 l containers.



DANGER! The JEM Compact Hazer Pro can run safely only on the specific haze fluid it is designed for. Use **ONLY JEM C-Plus Haze Fluid** as designated in this manual. **NEVER** use any other type of fluid, or toxic gas may be produced. You will probably also cause damage to the system that will invalidate the product warranty. Do not dilute haze fluid with water or any other liquid. Discard haze fluid if it becomes contaminated.

Basic service



Before servicing the JEM Compact Hazer Pro, read and observe all the precautions listed in “Safety information” on page 4. Any service not described in this section must be carried out by a Martin service technician.

To find your local Martin service center visit www.martin.com

Cleaning

Excessive dust, haze fluid, and dirt build-up will degrade performance and cause overheating and damage to the machine that is not covered by the product warranty. To maintain adequate cooling, dust must be cleaned from the outer casing and air vents of the machine periodically.



Isolate the machine from power and allow to cool completely before cleaning. The haze output nozzle remains hot for a period after use.

- Remove dust from the air vents with a soft brush, cotton swab, vacuum, or compressed air.
- Clean haze fluid residues from the haze output of the machine using a damp cloth.
- Clean the outer casing with a damp cloth only.

Martin Pro-Clean and Storage Fluid

Martin Pro-Clean & Storage Fluid is specially designed for optimizing performance while providing longevity of any effect machine. Martin Pro-Clean & Storage fluid is the ultimate cleaning solution for Martin atmospheric effect heat exchangers. This advanced preventative maintenance fluid has been utilized by Martin service technicians for years of both cleaning and storing effect machines. Utilizing Martin Pro-Clean & Storage Fluid on a regular basis reduces clogging and further extends the life of your Martin atmospheric effect machines. By using the highest grade chemicals available while remaining eco-friendly, Martin fluids are both effective and safe.

Instructions for use

Use fluid directly from container, **do not dilute**. Remove cap and safety seal; if inner safety seal has been tampered with, return product to point of purchase. Disconnect effect machine from power source before filling reservoir. When possible, remove reservoir from machine and carefully fill reservoir to desired level, taking care not to overfill or spill. Wipe up any spilled fluid with a damp cloth. Replace cap on container and store upright in a secure location.

Cleaning and Preventative Maintenance Procedure:

Use Martin Pro Clean and Storage Fluid after every 200 hours of operation or monthly depending on usage and duty cycle. In a well-ventilated area temporarily connect Martin Pro Clean and Storage Fluid to the effect machine being serviced or fill the machines provided fluid reservoir. Allow the machine to fully heat. When machine is ready activate the machine to run continuously for 30-45 minutes; use a timer function if available.

Storage Procedure:

Perform the above cleaning and preventative maintenance procedure. After procedure is completed simply run the machine until all fluid has been visibly purged from the fluid inlet tubing to prevent leaks and seepage.

Fuse replacement

The two fuses for the machine are located on the electronics board inside the unit.



DANGER! Disconnect the power supply before removing any covers. Live parts inside!

To replace a fuse, disconnect the power cord from the supply, unscrew the screws holding the top cover of the unit and remove the cover. The electronics board is located in the compartment under the display.

Remove the spent fuse and replace with one of exactly the same size and rating. The fuse type is indicated below. Contact Martin Service and Support if the fuse blows repeatedly.

F1

120V = 10AT
230V = 6.3AT

F2

120V = 3.15AT
230V = 3.15AT

Troubleshooting

Problem	Probable cause(s)	Suggested remedy
Machine will not produce haze when control panel set to RUN or remote control Haze switch turned on	Machine not at operating temperature	Wait until <i>HEAT</i> message no longer shown
	<i>HAZE</i> set to 0	Increase setting
	<i>TRUN</i> set to 0	Increase setting
	DMX signal present	Disconnect or turn off DMX controller
Machine can be fired from control panel or remote control, but not by DMX controller	DMX address setting incorrect	Change DMX address (page 13)
	Poor connection in DMX line	Check DMX cables and connections
	LINK menu is set to SEND	Set LINK menu to RECV
Haze output is weak	Machine requires priming	Prime machine (page 14)
Wet, greasy, non-uniform haze output, fluid drips or spits from nozzle, or very loud noise when firing machine	Incompatible haze fluid	Use approved fluid!
Machine appears dead	Mains fuse blown	Replace fuse (page 21)
	No power at AC cable inlet	Check power cable and circuit breaker
Machine causes DMX errors to occur on other units when connected to a DMX system	LINK menu is set to SEND	Set LINK menu to RECV

Status messages

message	reason
OFF	The heaters are Off, the unit is shut down.
HEAT	The unit is heating up to operating temperature.
RDY	The heater is at operating temperature, but Haze is not turned on (RUN set to STBY or HAZE set to 0%).
DMX	The heater is at operating temperature and the unit is under DMX control.
ON	The heater is in run mode and is producing haze.
CAL ERR	The machine has detected an error with its calibration settings and will not operate. Call Martin Service and Support.
TEMP ERR	The machine has detected an error in the temperature sensor and will not operate. Call Martin Service and Support.
WT44	The machine is running a cleaning cycle which lasts 45 seconds (number may be 45 to 0)

Resetting the machine after fluid out

If the machine runs out of fluid simply refill the fluid container and follow the priming instructions on page 14.

Technical Specifications

Physical

Length	532 mm (21 in.)
Width	224 mm (8.9 in.)
Height	278 mm (11 in.)
Height with hanging kit	296 mm (11.7 in.)
Weight, dry	8.5 kg (18.8 lb.)
Weight, filled	11 kg (24.3 lb.)

Performance

Coverage volume	3800 m ³ (134,196 ft ³) minute
Operating time with 2.5 l of fluid (min/max)	20/70 hours
Continuous effect output	
Ready time	1-minute

Control and programming

Control options	Digital control panel, DMX, optional digital remote control, master/client link mode
Control Parameters	Continuous or timer-controlled output
Haze and fan	Independent variable output, 0-100%
DMX channels	3 (Haze, Fan, Control)
Self-cleaning mode	Manually engaged or DMX trigger
DMX Compliance	ANSI E1.11 - USITT DMX512-A

Construction

Housing	Steel and aluminium
Color	Black
Heat exchanger	900 W, thermally protected
Blower fan	Integrated, 200-2500 RPM
Airflow control	Optional Air Director
Fluid pump	Oscillating piston, high pressure
Fluid management	Fluid out sensing, sealed for transportation
Fluid reservoir	2.5 l drop-in reservoir with quick-connect fitting

Installation

Mounting	Standing or optional hanging kit
Orientation	Up to +/- 30° from horizontal
Clearance around machine	100 mm (4 in.)

Connections

AC Power	Neutrik powerCON
DMX, link mode in/out	5-pin locking XLR
Remote Control	3-pin locking XLR
Firmware	AVR Socket

Electrical

EU Model

AC Power	220-240 V, 50/60 Hz
Main fuse	6.3 AT (slow-blow), 250 V
Typical power and current	1010 W, 4.4 A*

US Model

AC Power	100-130 V, 50/60 Hz
Main fuse	10 AT (slow-blow), 125 V
Typical power and current	1042 W, 8.68 A*

**Measurements made at nominal voltage. Allow for a deviation of +/- 10%*

Thermal

Minimum ambient temperature (Ta min).....	5° C (41° F)
Maximum ambient temperature (Ta max).....	40° C (104° F)
Exterior surface temperature, steady state, at 20°C ambient.....	30° C (86° F)
Maximum nozzle temperature.....	290° C (554° F)

Approvals

EU Model

EU Safety:	EN 60335-1+A15, EN 62233
EU EMC:	EN 61000-6-3
EU Immunity:.....	EN 61000-6-1
Australia/NZ (pending)	RCM

US Model

US Safety (pending).....	UL 998
Canada Safety	CSA C22.2 No 104-01

"Calibration factors have been developed and approved by the Actors' Equity Association and the Broadway League for use in measuring theatrical Haze with the JEM Compact Hazer Pro and JEM C-Plus Haze Fluid."



Included items:

Fluid reservoir, 2.5 l.....	P/N 34300521
Power input cable, EU, powerCON, stripped ends, 2.5 m (8.2 ft.) ..	P/N 11501041
Power input cable, US, powerCON, molded NEMA 5-15P, 2.5 m (8.2 ft.)	P/N 11501042
User Manual.....	P/N 35010033

Accessories

JEM Compact Hazer Pro, Air Director	P/N 92625011
JEM Compact Hazer Pro, Digital Remote Control	P/N 92765040
JEM Compact Hazer Pro, Flying Kit	P/N 92610003

Approved Fluids*

JEM C-Plus Haze Fluid
Martin Pro Clean and Storage Fluid

Approved Discontinued Fluids*

Martin Pro Clean Supreme

Installation Accessories

Half-coupler clamp	P/N 91602005
G-Clamp (vertical hanging suspension only)	P/N 91602003
Quick trigger clamp (vertical hanging suspension only)	P/N 91602007
Safety cable, SWL 60 kg (132 lb.), BGV C1/ DGUV 17, black	P/N 91604006

Service Tools

Epsilon 5 AVR Programmer	P/N 50502004
Temperature Calibration Box	P/N 62622005

**Various sizes available – contact your dealer or see martin.com for details*

Ordering information

JEM Compact Hazer Pro, EU	P/N 92225950
JEM Compact Hazer Pro, US	P/N 92225960

Specifications subject to change without notice. For the latest product specifications, see www.martin.com

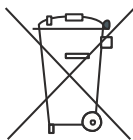

Disposing of this product

Martin™ products are supplied in compliance with Directive 2002/96/EC of the European Parliament and of the Council of the European Union on WEEE (Waste Electrical and Electronic Equipment), as amended by Directive 2003/108/EC, where applicable.

Help preserve the environment! Ensure that this product is recycled at the end of its life. Your supplier can give details of local arrangements for the disposal of Martin products.

Notes



www.martin.com • Olof Palmes Allé 18 • 8200 Aarhus N • Denmark
Tel: +45 8740 0000 • Fax: +45 8740 0010