



## Product Description

The VQNET 60 is a full range, three-way loudspeaker system designed for applications which require very high output capability with class leading pattern control. Integrated with cutting edge digital signal processing, network control and dual channel Class D amplification, the VQNET 60 is perfectly suited for use in arrays or singly in demanding applications. Unlike line array solutions, the VQNET 60 can produce enough power and clarity to be used individually maintaining your building's aesthetics.

With low frequency extension to 90Hz, the VQNET 60 can be combined with various subwoofers for extended bandwidth.

Horn design involves balancing compromise.....until now.

Our unique approach in keeping what is effectively a Dual Concentric behind a single horn gives us many performance advantages. Performance of the VQNET 60 in terms of accuracy & sound quality is second to none.

The VQNET 60 incorporates a unique driver technology to radiate a coherent single point source for superior dispersion control when coupled to a PSW™ (Point Source Waveguide). This advanced design aligns the acoustical centres of the transducers providing a single coherent wavefront emanating from the throat. The PSW™ waveguide achieves an optimum balance of extremely well controlled coverage, smooth frequency response, and natural sound character.

The low frequency section, two (12") low frequency transducers, offers high power handling and low power compression for exceptionally high continuous SPL capability. A newly designed LF loading design provides the highest possible sensitivity for low/mid frequency output.

The modular approach of amplifiers, processing, monitoring and drivers designed into each loudspeaker enables acoustic optimization for the speaker to perform as a unified whole. The intuitive setup software, integrated processing, tuning control, performance diagnostics and protection produces an easy to install and exceptionally high performance networkable loudspeaker. VNET™ supports free network topology so that the loudspeakers can be arranged in a daisy chain, linked in a star configuration or in any combination of both. Implementation of the network between nodes is via high quality rugged Neutrik Ethercon connectors, which are compatible with standard RJ45 plugs, and CAT5 cable. Each speaker has a unique address for auto-location on the network.

System commissioning and ongoing venue network control, incorporating real time diagnostics of electronics and drive unit, are all managed by the exclusive VNET™ software package. Supplied with each unit, this intuitive Windows tool controls all of the critical install, commissioning and performance monitoring functions. A standard wireless LAN-to-serial bridge can also be used to communicate with the network.

The VQNET 60 is part of an expanding line up of VQ products, addressing the requirement for compact dimensions without compromising performance in any way.

## VNET™ Network

An RS485 interface is used for the serial data, with a twisted pair to send and receive information to a high number of nodes over very long distances. Operating a shared bus system, so that a single computer can control any node on that bus, also means that status information can be gathered from any of the devices. The RS-485 differential signal is very robust, while its noise immunity and long-distance capability ensure it is one of the most popular communications methods used in industry.

Only data to control setup functions and ongoing system diagnostics is carried over the network. As each VNET™ loudspeaker controls its own DSP functions any unforeseen problem would be isolated to only that particular node and audio will still be delivered.

Speakers are automatically identified on the network software set up screen with factory default names. The name can be edited to reflect their actual location on the network, with physical location confirmation by selecting the 'Flash' function to activate an LED mounted on the front of the loudspeaker.

The loudspeakers are fully calibrated at the factory, avoiding the need to input the correct speaker management settings or any dynamics at the point of install.

## Features

- "PSW™ Waveguide" - Point source design (Patent applied for).
- Excellent Phase Coherence
- Perfect time alignment without the associated problems of multi source interference
- Compact Dimensions
- Class leading directivity characteristics
- Extremely high sensitivity, therefore high SPL's can be achieved with a very modest amount of amplifier power
- Exceptional transient response

## Applications

- Large Houses of Worship
- Large Corporate AV applications
- Stadiums & other Sports facilities
- Dance Clubs
- Live sound – concert halls, theatres, open-air venues

Tannoy United Kingdom  
 Tannoy Deutschland  
 Tannoy Middle East  
 TC|Group International  
 TC|Group Americas

T: 00 44 (0) 1236 420199  
 T: 00 49 (180) 1111 881  
 T: 00 971 (04) 4401208  
 T: 00 45 8742 7000  
 T: 00 1 (519) 745 1158

E: enquiries@tannoy.com  
 E: enquiries@tannoy.com  
 E: enquiries@tannoy.com  
 E: info@tcgroup-international.com  
 E: info@tcgroup-americas.com

# tannoy®.com



## TECHNICAL SPECIFICATIONS

### System VQ60 NET

<b>System Type</b>	3-Way Full Range - Point Source		
<b>Frequency Response (-3dB) <sup>(1)</sup></b>	115Hz - 23kHz		
<b>Frequency Range (-10dB) <sup>(1)</sup></b>	90Hz - 27kHz		
<b>Dispersion (-6dB)</b>	60 degrees conical		
<b>Driver Complement</b>	2 x 300mm (12.00") Low Frequency Transducers, Semi Horn Loaded Dual Concentric™ Compression PSW™		
<b>MF/HF driver loaded into a single Waveguide</b>			
<b>Crossover</b>	450Hz (DSP Generated) 7kHz (passive)		
<b>Directivity Factor (Q)</b>	21.2 averaged 1kHz to 10kHz		
<b>Directivity Index (DI)</b>	13.3 averaged 1kHz to 10kHz		
<b>Rated Maximum SPL <sup>(2)</sup></b>	LF 134dB (average) 140dB (peak) MF/HF 138dB (average) 144dB (peak)		
<b>Distortion</b>	2nd Harmonic	3rd Harmonic	
<b>110dB SPL</b>			
250Hz	2.726	1.385	
2kHz	1.030	0.231	
5kHz	1.807	0.284	
<b>115dB SPL</b>			
250Hz	2.917	1.447	
2kHz	1.738	0.256	
5kHz	2.948	0.311	
<b>120dB SPL</b>			
250Hz	2.941	1.395	
2kHz	3.016	0.376	
5kHz	5.058	0.387	
<b>125dB SPL</b>			
250Hz	3.051	1.371	
2kHz	5.230	0.752	
5kHz	8.650	0.948	
<b>Electronics</b>			
<b>Efficiency</b>	>85% typically.		
<b>Damping Factor</b>	120 ref 8 Ohms		
<b>Distortion</b>	<0.05% @ 1kHz -3dB output (22kHz bandwidth)		
<b>Input Impedance</b>	5.6 kOhms unbalanced, 11.2 kOhms balanced		
<b>Output Power (Programme)</b>	LF - 800W MF/HF - 800W (limited to 400W)		
<b>Input Sensitivity</b>	1.4V (+5.5dBu)		
<b>System Type</b>	Dual channel Class D		

### DSP System

<b>Comms Facilities</b>	Firmware updatable and selected parameters editable
<b>Communications</b>	Serial - RS485 Proprietary message format
<b>Dynamic Range</b>	112dB(A) typical
<b>DSP</b>	3rd generation SHARC
<b>Sampling Frequency</b>	96kHz 24 bit A/D-D/A word length
<b>Format</b>	1 IN - 2 OUT

### PSU Specifications

<b>Input Connector</b>	Locking Neutrik Powercon
<b>Voltage Selection</b>	Automatic (115 / 230V, 45 - 65Hz)
<b>Type</b>	High current, high frequency switch mode
<b>Efficiency</b>	>90% typical
<b>Input voltage</b>	100V / 115V / 230V nominal +/-10%
<b>Mains fuse</b>	External
<b>Fuse type</b>	T10AT
<b>Other features</b>	Automatic soft start
<b>Current Draw</b>	115V 230V
<b>Startup (inrush)</b>	3.5A 1.9A
<b>idle</b>	1.1A 0.56A
<b>Max</b>	3.5A 1.7A

### Construction

<b>Enclosure</b>	18mm (0.71") birch plywood. Vented and internally braced.
<b>Grille</b>	Powder coated perforated steel grille
<b>Finish</b>	Black or white textured paint (custom colours on request)
<b>Connectors</b>	1 x female XLR (input) 1 x male XLR (link) 1 x RJ45 (network in) 1x RJ45 (network link) 1 x Neutrik Powercon
<b>Controls &amp; Indicators</b>	LED on front of cabinet behind grille. (wink indicator for locating & assigning) Power LED (blue), Signal LED (green), Limit LED (red), User DSP - defeat switch, Power switch
<b>Fittings</b>	8 x Recessed carrying handles 12 x M10 flying inserts
<b>Dimensions</b>	925mm x 694mm x 515mm (36.42" x 27.32" x 20.28")
<b>NET Weight</b>	80.5kg (177.1 lbs)

#### Notes:

- (1) Average over stated bandwidth. Measured at 3 metres on axis, then referred to 1 metre  
(2) Unweighted pink noise input, measured at 3 metres in an anechoic chamber, then referred to 1 metre

A full range of measurements, performance data, and Ease™ Data can be downloaded from [www.tannoy.com](http://www.tannoy.com)

Tannoy operates a policy of continuous research and development. The introduction of new materials or manufacturing methods will always equal or exceed the published specifications.

### Ordering Information

PART NUMBER	MODEL NAME	COLOUR	PACKED QUANTITY
8001 4840	VQNET 60	BLACK	1
8001 4841	VQNET 60	WHITE	1

Tannoy United Kingdom  
Tannoy Deutschland  
Tannoy Middle East  
TC|Group International  
TC|Group Americas

T: 00 44 (0) 1236 420199  
T: 00 49 (180) 1111 881  
T: 00 971 (04) 4401208  
T: 00 45 8742 7000  
T: 00 1 (519) 745 1158

E: [enquiries@tannoy.com](mailto:enquiries@tannoy.com)  
E: [enquiries@tannoy.com](mailto:enquiries@tannoy.com)  
E: [enquiries@tannoy.com](mailto:enquiries@tannoy.com)  
E: [info@tcgroup-international.com](mailto:info@tcgroup-international.com)  
E: [info@tcgroup-americas.com](mailto:info@tcgroup-americas.com)

[tannoy.com](http://tannoy.com)



## PERFORMANCE MEASUREMENTS

Frequency Response

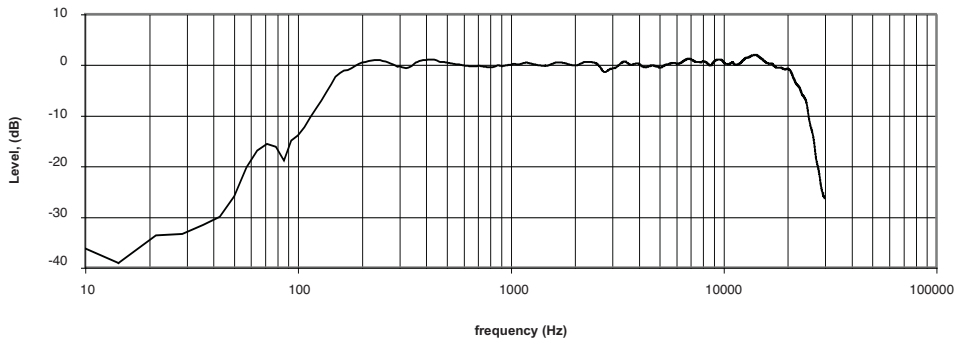

ANECHOIC FREQUENCY RESPONSE

Frequency Response - Horizontal Off-axis

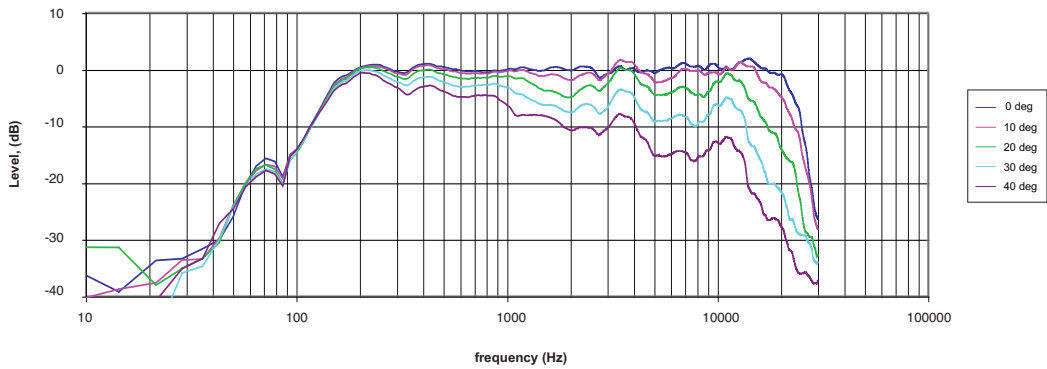

HORIZONTAL OFF AXIS RESPONSE

Frequency Response - Upper Vertical Off-axis

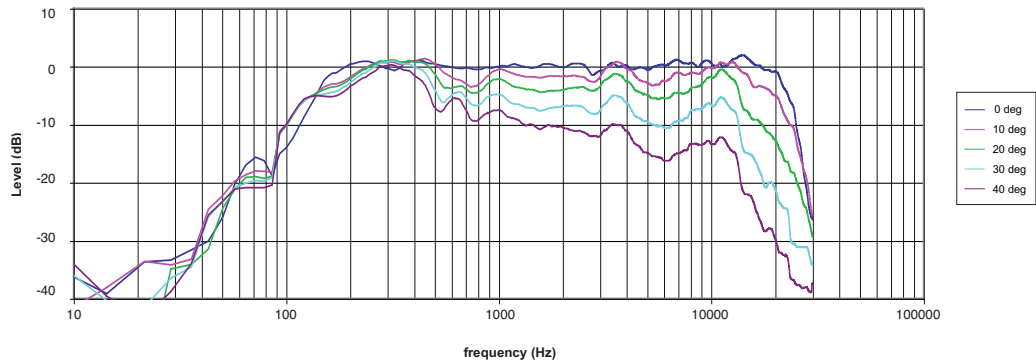

VERTICAL UPPER OFF AXIS RESPONSE

Tannoy United Kingdom  
 Tannoy Deutschland  
 Tannoy Middle East  
 TC|Group International  
 TC|Group Americas

T: 00 44 (0) 1236 420199  
 T: 00 49 (180) 1111 881  
 T: 00 971 (04) 4401208  
 T: 00 45 8742 7000  
 T: 00 1 (519) 745 1158

E: enquiries@tannoy.com  
 E: enquiries@tannoy.com  
 E: enquiries@tannoy.com  
 E: info@tcgroup-international.com  
 E: info@tcgroup-americas.com

tannoy®.com



## PERFORMANCE MEASUREMENTS

Frequency Response - Lower Vertical Off-axis

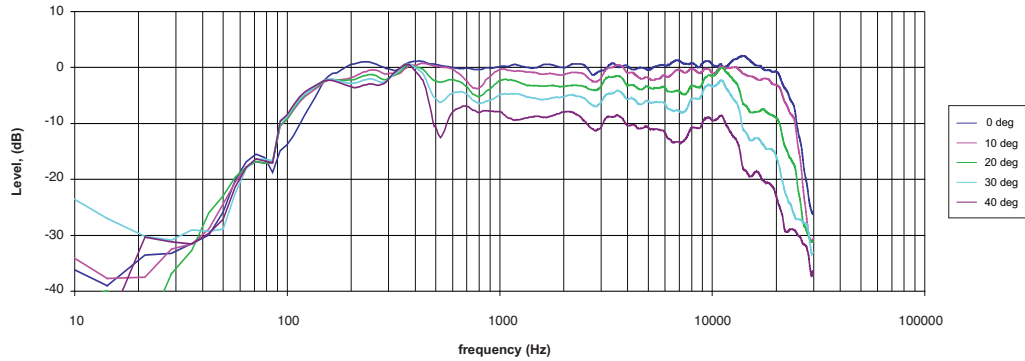

VERTICAL  
LOWER  
OFF AXIS  
RESPONSE

Beamwidth vs Frequency

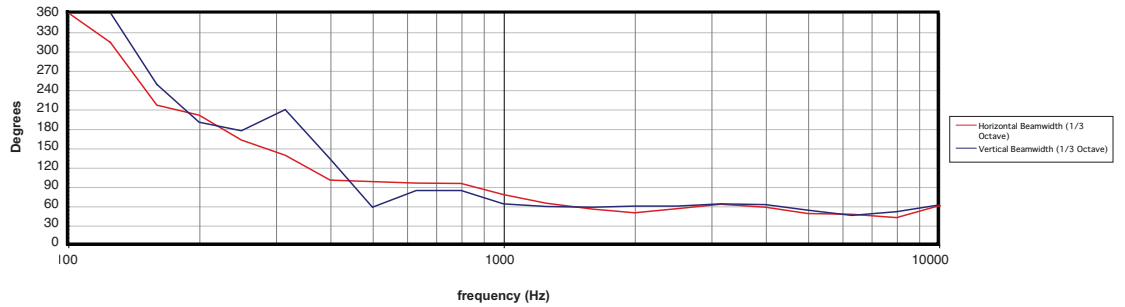

BEAMWIDTH

Q vs Frequency

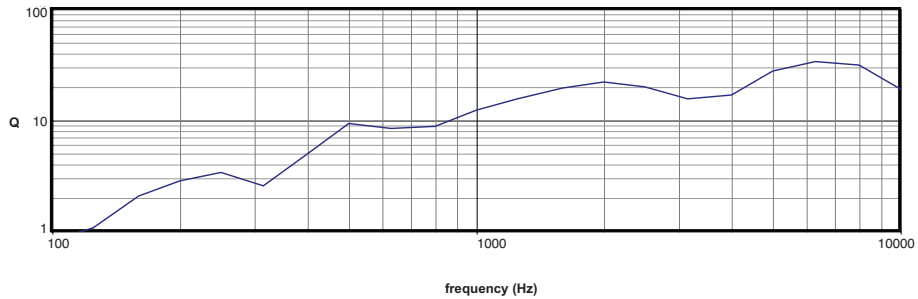

Q VS FREQUENCY

Tannoy United Kingdom  
 Tannoy Deutschland  
 Tannoy Middle East  
 TC|Group International  
 TC|Group Americas

T: 00 44 (0) 1236 420199  
 T: 00 49 (180) 1111 881  
 T: 00 971 (04) 4401208  
 T: 00 45 8742 7000  
 T: 00 1 (519) 745 1158

E: enquiries@tannoy.com  
 E: enquiries@tannoy.com  
 E: enquiries@tannoy.com  
 E: info@tcgroup-international.com  
 E: info@tcgroup-americas.com

tannoy.com



## PERFORMANCE MEASUREMENTS

DI vs Frequency

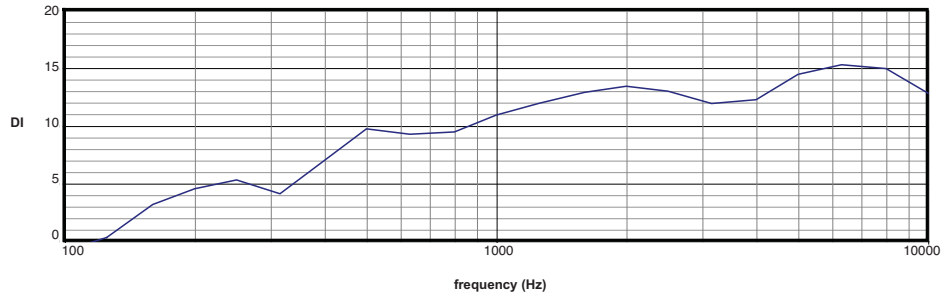

DIRECTIVITY  
INDEX

Tannoy United Kingdom  
Tannoy Deutschland  
Tannoy Middle East  
TC|Group International  
TC|Group Americas

T: 00 44 (0) 1236 420199  
T: 00 49 (180) 1111 881  
T: 00 971 (04) 4401208  
T: 00 45 8742 7000  
T: 00 1 (519) 745 1158

E: enquiries@tannoy.com  
E: enquiries@tannoy.com  
E: enquiries@tannoy.com  
E: info@tcgroup-international.com  
E: info@tcgroup-americas.com

tannoy®.com



## PERFORMANCE MEASUREMENTS POLAR PLOTS (1/3 OCTAVE)

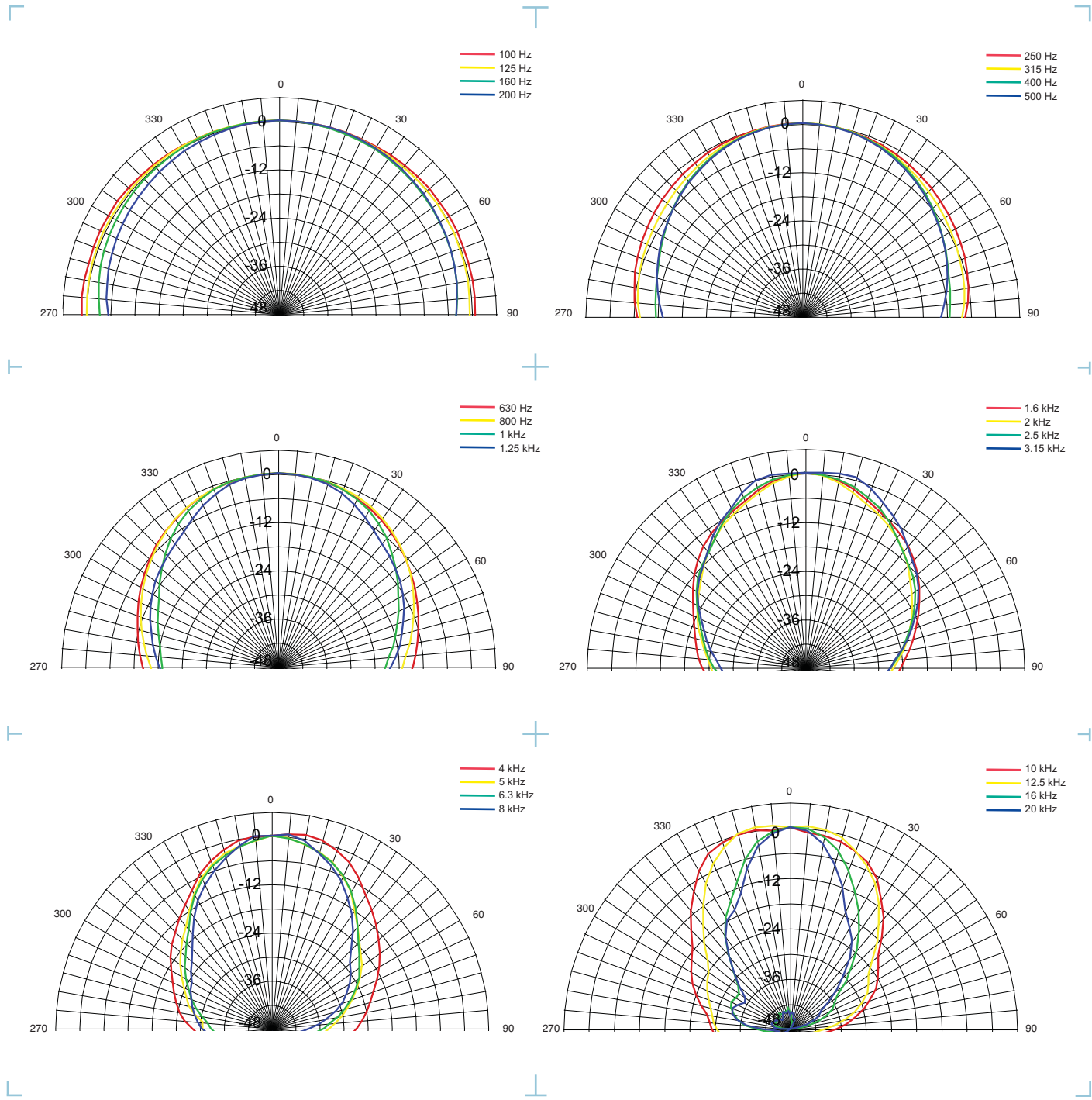

Tannoy United Kingdom  
 Tannoy Deutschland  
 Tannoy Middle East  
 TC|Group International  
 TC|Group Americas

T: 00 44 (0) 1236 420199  
 T: 00 49 (180) 1111 881  
 T: 00 971 (04) 4401208  
 T: 00 45 8742 7000  
 T: 00 1 (519) 745 1158

E: enquiries@tannoy.com  
 E: enquiries@tannoy.com  
 E: enquiries@tannoy.com  
 E: info@tcgroup-international.com  
 E: info@tcgroup-americas.com

tannoy.com



## PERFORMANCE MEASUREMENTS POLAR PLOTS (1/3 OCTAVE)

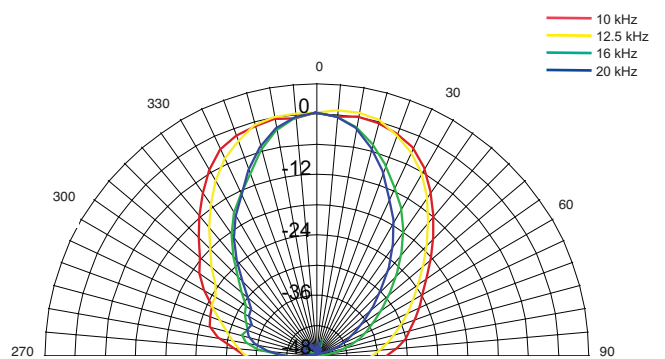
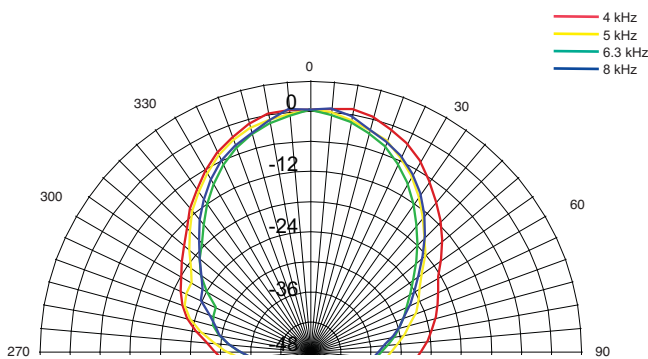
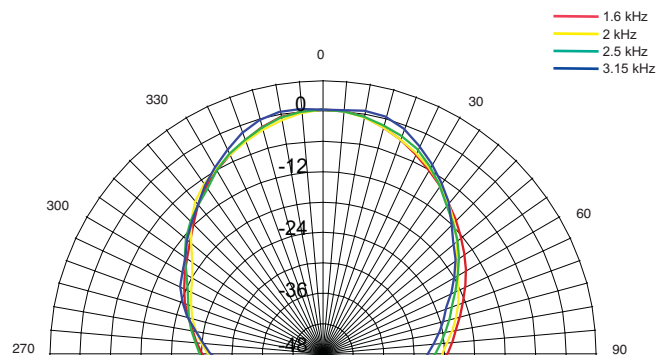
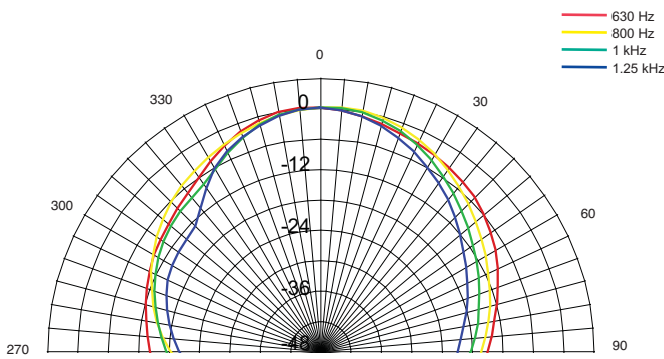
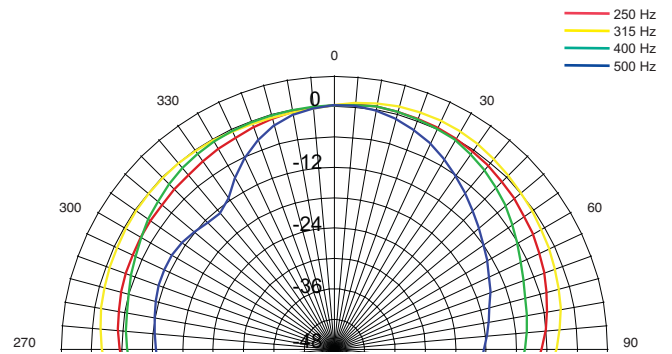
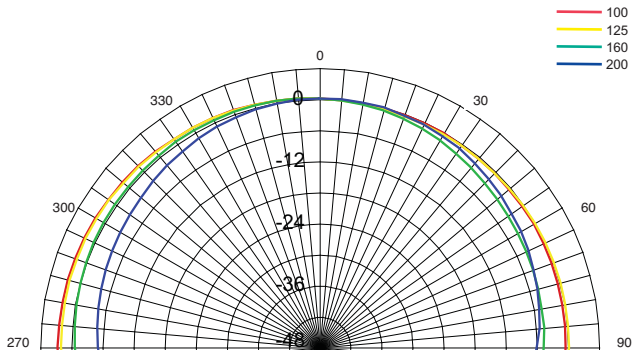

Tannoy United Kingdom  
 Tannoy Deutschland  
 Tannoy Middle East  
 TC|Group International  
 TC|Group Americas

T: 00 44 (0) 1236 420199  
 T: 00 49 (180) 1111 881  
 T: 00 971 (04) 4401208  
 T: 00 45 8742 7000  
 T: 00 1 (519) 745 1158

E: enquiries@tannoy.com  
 E: enquiries@tannoy.com  
 E: enquiries@tannoy.com  
 E: info@tcgroup-international.com  
 E: info@tcgroup-americas.com

tannoy.com



# VQNET 60

# TANNOY®

## VNET SOFTWARE

### VNET™ SOFTWARE

The loudspeakers are fully calibrated at the factory, avoiding the need to input the correct speaker management settings or dynamics at the point of install. This frees the installer to concentrate instead on room measurement and system optimisation. System commissioning and ongoing venue network control, incorporating real time diagnostics of electronics and drive unit, are all managed by the exclusive VNET™ software package. Supplied with each unit, this intuitive Windows tool controls all of the critical install, commissioning and performance monitoring functions. A standard wireless LAN-to-serial bridge can be used to communicate with the network, allowing the commissioning engineer to sit in the auditorium communicating from a laptop on 802.11b



### MONITORING & TELEMETRY FUNCTIONS

During normal operation the speakers on the network will appear as minimised panels in the form of a status monitor icon (Monicon) on the computer screen. These are laid out to reflect the physical layout of the speakers within the venue so that the user can monitor system status and component condition at a glance. The minimised panels can be expanded to reveal highly detailed information in real time:



- Input clip indicator
- Two output limiter bar graph meter
- Heat sink temperature bar graph meter
- Amplifier clip indicators (HF & LF on full range units)
- Transducer Failure Indicators (HF & LF on full range units)
- Amplifier protect status indicator

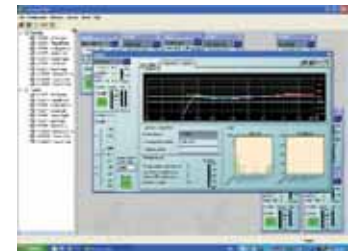

### VNET™ Software Features

The on-screen control panel for each device in the network has a properties tab consisting of the following:

- Model Name is factory set with product model name
- Network Handle (read only) is a numerical value set at the time of manufacture to uniquely identify the device on the network
- Device Name is the specific user defined name, such as 'Stage.Left' or 'Delay 1'
- Firmware Version (read only) is a numerical value of firmware version running in the device
- Configuration Name is the 12 character name the user can define to describe the current settings (such as 'Live Mode')
- Current 'Voice' profile indication (read only) is a numerical value indicating the current speaker 'voicing' profile (the factory set equalization, crossover, & dynamics functions)
- Software file loader in VNET™ allows a future modification to the software to be uploaded, such as a 'voicing' change or revised control software with new features
- Record of any temperature or current shutdowns
- Record of the number of power cycles
- Rolling four day bar graphs recording amplifier temperature and any dynamics applied

### Signal Processing

- Gain Section: input gain fader with edit box (-30 to +15dB in 0.2dB steps)
- Input Mute: On, Off
- High-Pass Filter section: frequency spin / edit box and shape drop-down box
- Low-Pass Filter Section: frequency spin / edit box and shape drop-down box
- Equaliser Section: high resolution input EQ curve display
- Low Shelf Band: frequency spin / edit box, slope spin / edit box and boost-cut / edit box
- High Shelf Band: frequency spin / edit box, slope spin / edit box and boost-cut / edit box
- Parametric EQ Bands (x 8): frequency spin / edit box, slope spin / edit box and boost-cut / edit box
- Delay Section: delay spin / edit box (up to 180ms)

Tannoy United Kingdom  
 Tannoy Deutschland  
 Tannoy Middle East  
 TC|Group International  
 TC|Group Americas

T: 00 44 (0) 1236 420199  
 T: 00 49 (180) 1111 881  
 T: 00 971 (04) 4401208  
 T: 00 45 8742 7000  
 T: 00 1 (519) 745 1158

E: enquiries@tannoy.com  
 E: enquiries@tannoy.com  
 E: enquiries@tannoy.com  
 E: info@tcgroup-international.com  
 E: info@tcgroup-americas.com

# tannoy®.com



# VQNET 60

# TANNOY®

## DIMENSIONAL SKETCHES

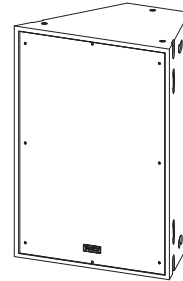
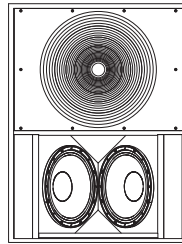
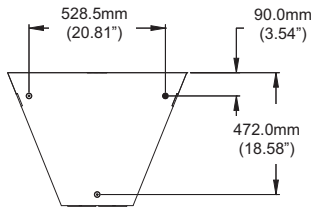
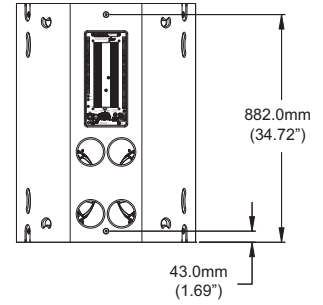
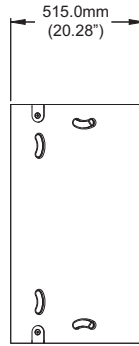
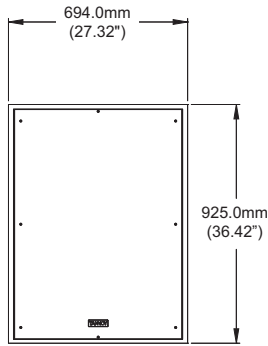

## INPUT PANEL

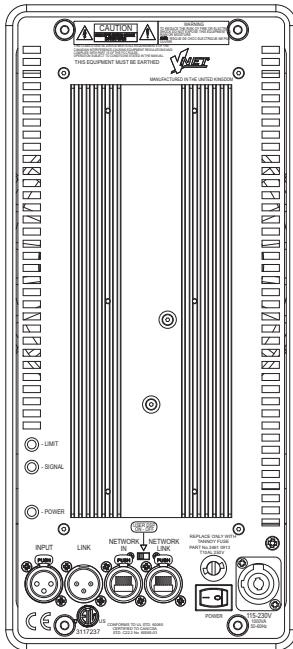

Tannoy United Kingdom  
 Tannoy Deutschland  
 Tannoy Middle East  
 TC|Group International  
 TC|Group Americas

T: 00 44 (0) 1236 420199  
 T: 00 49 (180) 1111 881  
 T: 00 971 (04) 4401208  
 T: 00 45 8742 7000  
 T: 00 1 (519) 745 1158

E: enquiries@tannoy.com  
 E: enquiries@tannoy.com  
 E: enquiries@tannoy.com  
 E: info@tcgroup-international.com  
 E: info@tcgroup-americas.com

# tannoy®.com



## OPTIONAL ACCESSORIES

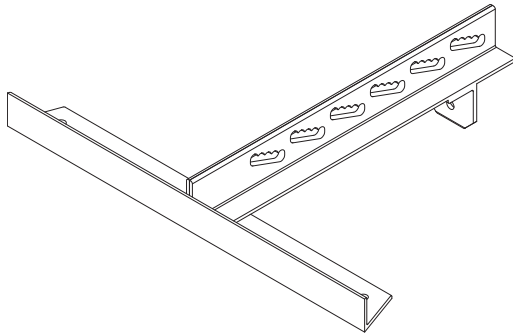

VQ FLYING BRACKET  
(SINGLE POINT HANGING BRACKET)

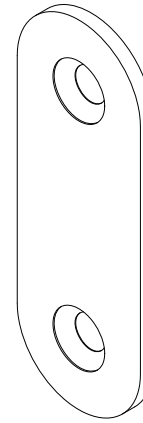

VQ LINK (LINK PLATE)

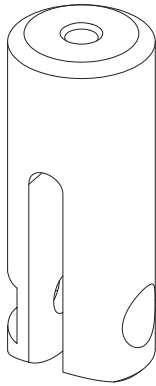

VQ ROD END 12mm

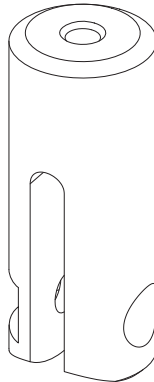

VQ ROD END 1/2in UNC

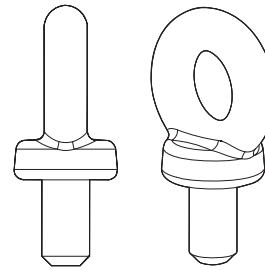

VEB FORGED EYEBOLT

### Ordering Information

PART NUMBER	MODEL NAME	COLOUR	PACKED QUANTITY
8001 5250	VQ Flying Bracket (Single Point Hanging Bracket)	BLACK	1
7900 1055	VQ Link (Link Plate)	BLACK	3
8001 5260	VQ Rod End 12	BLACK	1
8001 5261	VQ Rod End 1/2in UNC	BLACK	1
8001 2820	VEB Forged Eyebolt	-	3

Tannoy United Kingdom  
Tannoy Deutschland  
Tannoy Middle East  
TC|Group International  
TC|Group Americas

T: 00 44 (0) 1236 420199  
T: 00 49 (180) 1111 881  
T: 00 971 (04) 4401208  
T: 00 45 8742 7000  
T: 00 1 (519) 745 1158

E: enquiries@tannoy.com  
E: enquiries@tannoy.com  
E: enquiries@tannoy.com  
E: info@tcgroup-international.com  
E: info@tcgroup-americas.com

tannoy®.com



## VNET SC1 CONTROLLER



VNET SC1 Controller

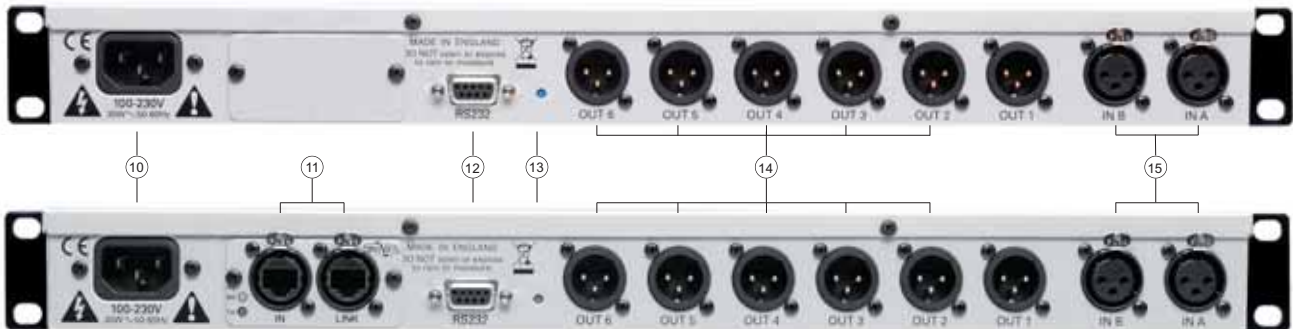

VNET SC1 Controller (network enabled)

### Front Panel

- ① **INPUT SIGNAL INDICATORS**  
A set of three pairs of LEDs indicate signal present, +4dBu and input clip for each channel.
- ② **STORE BUTTON**  
The unit has 45 preset locations.
- ③ **RECALL BUTTON**  
To recall a preset, press the recall button and use parameter knob A to select the required preset.
- ④ **CHANNEL SELECT BUTTONS**  
The currently selected input or output channel is shown in the top left corner of the display. Pressing the channel select buttons scrolls through the available inputs and outputs.
- ⑤ **EDIT PARAMETER SELECT BUTTON**  
The name of the edit parameter page is displayed in the bottom left portion of the LCD.
- ⑥ **DISPLAY SCREEN**  
Preset, channel, parameter and status information is shown on the 2x 24-character text display. In most screens the currently selected channel is displayed being the upper line and the edit parameter on the lower line.
- ⑦ **PARAMETER EDIT ENCODERS**  
Three velocity sensitive parameter knobs are used to adjust parameters shown on the display. Up to three parameters at a time are displayed on the screen.
- ⑧ **LIMITER INDICATOR**  
Two LEDs are provided for each output channel.
- ⑨ **MUTE BUTTONS**  
Each output has a mute button and associated mute status LED.

### Rear Panel

- ⑩ **POWER INLET**  
The processor has a switch mode power supply that is capable of operating with a nominal mains voltage of 85V to 240V, 50/60Hz without re-configuration.
- ⑪ **VNET™ NETWORK PORTS**  
The network enabled VNET SC1 controller features two network ports for connection to any VNET™ system.
- ⑫ **COMMUNICATIONS PORT CONNECTOR**  
Tannoy VNET SC1 processors may be controlled entirely from a PC running VNET™ software using this RS232 serial port connector. This port is also used for updating the firmware in the unit.
- ⑬ **SECURE MODE SWITCH**  
A momentary button is fitted behind the rear panel, between the output XLRs and the RS232 port. When activated, this will disable all the front panel controls so they cannot affect the signal path, making the unit secure against tampering.
- ⑭ **AUDIO OUTPUT CONNECTORS**  
The processed outputs are impedance balanced.
- ⑮ **AUDIO INPUT CONNECTORS**  
All audio connections are fully balanced.

Tannoy United Kingdom  
Tannoy Deutschland  
Tannoy Middle East  
TC|Group International  
TC|Group Americas

T: 00 44 (0) 1236 420199  
T: 00 49 (180) 1111 881  
T: 00 971 (04) 4401208  
T: 00 45 8742 7000  
T: 00 1 (519) 745 1158

E: enquiries@tannoy.com  
E: enquiries@tannoy.com  
E: enquiries@tannoy.com  
E: info@tcgroup-international.com  
E: info@tcgroup-americas.com

tannoy®.com



### OPTIONAL VNET™ USB AND RS232 INTERFACE

The rack-mountable VNET™ interface allows for communication between a VNET™ network and computer.

If communicating with a non-networked SC1 direct communication via the PC & SC1 can be made with a standard serial lead, or USB-RS232 cable.

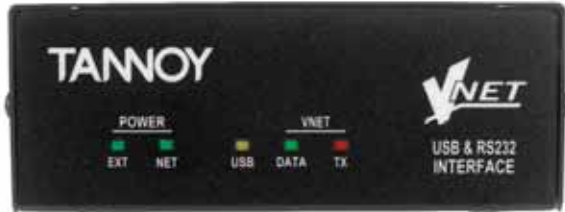

### OPTIONAL VNET™ ACCESSORY POWER SUPPLY

The PSU is only required when communication with a VNET™ network is by RS232.



### OPTIONAL RACK MOUNT KIT

This 1U bracket allows you to rack mount up to three VNET™ interface accessories in a standard 19" equipment rack.



### Ordering Information

PART NUMBER	MODEL NAME	BAFFLE / GRILLE COLOUR	PACKED QUANTITY	PACKED WEIGHT
8001 4450	VNET™ USB / RS 232 Interface	Black	1	0.75 (1.65lb)
8001 4460	VNET™ Power Supply Interface	Black	1	0.75 (1.65lb)
8001 4470	VNET™ Interface 1U rack mount kit	Black	1	0.75 (1.65lb)

Tannoy United Kingdom  
 Tannoy Deutschland  
 Tannoy Middle East  
 TC|Group International  
 TC|Group Americas

T: 00 44 (0) 1236 420199  
 T: 00 49 (180) 1111 881  
 T: 00 971 (04) 4401208  
 T: 00 45 8742 7000  
 T: 00 1 (519) 745 1158

E: enquiries@tannoy.com  
 E: enquiries@tannoy.com  
 E: enquiries@tannoy.com  
 E: info@tcgroup-international.com  
 E: info@tcgroup-americas.com

# tannoy®.com



## Architectural specifications

The loudspeaker shall consist of a Dual Concentric™ Compression driver with a 3.5" Midrange voice coil and a 2" High Frequency voice coil, both mounted in a common subsystem with a common 2" exit. This Dual Concentric™ compression driver shall be coupled to a PSW™ (Point Source Waveguide) constant directivity horn operating over the frequency range of 450Hz to 23kHz. The low frequency section consists of two 12" (300mm) woofers, and shall be mounted in a semi-horn loaded enclosure to provide significant off axis attenuation below 450Hz. The low and Mid/High frequency elements shall be driven by an integrated dual channel Class D amplifier through a DSP generated crossover. The loudspeaker shall have user configurable DSP functionality. A variable high pass filter shall be provided for use with subwoofers.

The loudspeaker shall be trapezoidal in shape.

Performance of the loudspeaker shall meet or exceed the following criteria:

The Low Frequency section shall be capable of producing a peak output of 141dB SPL on axis at 1 meter. The Mid/High section shall be capable of producing a peak output of 144dB SPL on axis at 1 meter.

The dispersion of the loudspeaker shall be 60 degrees conical (-6dB). The enclosure shall be of birch plywood construction and internally braced. The enclosure shall be fitted with eight integral carrying handles, and twelve M10 inserts for flying hardware. The enclosure shall not exceed the following dimensions (H x W x D): 925mm x 694mm x 515mm (36.42" x 27.32" x 20.28").

The loudspeaker shall be the Tannoy... VQNET 60.





