

VX Series

Professional Loudspeakers



TANNOY

Operation Manual

Important Safety Instructions



The lightning flash with arrowhead symbol within an equilateral triangle, is intended to alert the user to the presence of uninsulated "dangerous voltage" within the product's enclosure that may be of sufficient magnitude to constitute a risk of electric shock to persons.

1. Read these instructions.
2. Keep these instructions
3. Heed all warnings.
4. Follow all instructions.
5. Do not use this apparatus near water.
6. Clean only with a dry cloth.
7. Do not block any ventilation openings. Install in accordance with the manufacturer's instructions.
8. Do not install near any heat sources such as radiators, heat registers, stoves, or other apparatus (including amplifiers that produce heat).
9. Only use attachments/accessories specified by the manufacturer.
10. Use only with a cart, stand, tripod, bracket, or table specified by the manufacturer, or sold with the apparatus. When a cart is used, use caution when moving the cart/apparatus combination to avoid injury from tip-over.
11. Refer all servicing to qualified service personnel. Servicing is required when the apparatus has been damaged in any way, such as power-supply cord or plug is damaged, liquid has been spilled or objects have fallen into the apparatus, the apparatus has been exposed to rain or moisture, does not operate normally, or has been dropped.



The exclamation point within an equilateral triangle is intended to alert the user to the presence of important operating and maintenance (servicing) instructions in the literature accompanying the product.

SAFETY WARNING

Do not remove any covers, loosen any fixings or allow items to enter any aperture.

SAFETY WARNING

Objects filled with liquids should not be placed on this apparatus.

AVERTISSEMENT DE SECURITE

Ne retirez pas les couvercles, ne desserrez pas les fixations et ne laissez aucune pièce s'introduire dans les ouvertures.

AVERTISSEMENT DE SECURITE

Ne placez pas d'objets contenant du liquide à proximité de l'appareil.

Table of Contents

1. Introduction	4
2. Unpacking and Visual Checks	4
2.1 Preliminary Recommendation.....	4
3. Connectors / Cabling	5
4. Polarity Checking	6
5. Amplification & Power Handling	6
6. Crossovers and Bi-amp Configuration	7
7. Equalisation	9
8. Arraying	9
9. Dimensions	10
10. Rigging and Safety Procedures	16
11. Service Parts & Accessories	17
12. Technical Specifications	18
13. Warranty	22
14. Declaration of Conformity	23

1. Introduction

Designed, engineered and built in the United Kingdom, the VX Series from Tannoy comprises a range of passive loudspeakers for demanding professional and commercial sound applications. At the heart of all VX Series loudspeakers is Tannoy's acclaimed Dual Concentric™ driver technology. Unlike conventional drivers, Dual Concentric combines a high frequency driver and a low-mid driver on a common axis, creating a true point source for all reproduced sounds. Dual Concentric eliminates the time alignment problems inherent with all enclosures employing separated drivers, thus ensuring outstanding definition, detail and intelligibility at all points in the listening area.

All VX Series loudspeakers are designed to perform with very high efficiency and exceptionally low distortion, even when operating near peak output levels. All components are housed in rugged birch plywood enclosures, with larger models equipped with double-chamfered Integrip™ recessed handles for easy one- or two-handed carrying. Reflecting Tannoy's reputation for reliability, all VX Series loudspeakers are backed by a five-year warranty.

Within the VX Series, system designers can choose from a variety of sizes, power levels and coverage patterns to suit particular requirements. For extended bass performance, models with the ".2" designation augment the Dual Concentric LF driver with a second matched LF driver. The "HP" designation indicates extended power handling capabilities, while the "Q" suffix indicates incorporation on the new Q-Centric Waveguide™ (QCW™) for applications requiring an asymmetrical coverage pattern. The QCW horn can be rotated in a matter of minutes, allowing placement of the 75 x 40 degree pattern with either horizontal or vertical orientation.

2. Unpacking and Visual Checks

Each Tannoy VX Series loudspeaker is carefully tested and inspected prior to shipment. After unpacking, please inspect for any exterior physical damage, and save the carton and any relevant packaging materials in case the loudspeaker again requires packing and shipping. In the event that damage has been sustained in transit notify your dealer and the shipping carrier immediately.

2.1 Preliminary Recommendation

VX Series loudspeakers can produce high sustained output levels for long periods of time. If users are in close proximity, these levels could lead to permanent hearing damage. Because Tannoy loudspeakers have a natural-sounding, flat frequency response and very low distortion, users may not be aware of the potential hazard. For continuous exposure to high levels, we recommend use of a sound level meter to ensure noise levels are within safety limits. The meter should be capable of integrating levels over a period of exposure in conformance with noise control standards.

3. Connectors / Cabling

On VX Series loudspeakers, connector types available vary by model, as detailed below:

VX 5.2, VX 6, VX 8

Inputs on 1 x speakON® 4-pole, 1x binding post pair. Binding posts are connected in parallel to speakON® 1+ and 1-. Not bi-amp capable.

VX 8M

Inputs on 2 paralleled speakON 4 pole connectors. Not bi-amp capable

VX 8.2, VX 12

Inputs on 2 x speakON® 4-pole and 2 x barrier strip terminals. Both barrier strip terminal pairs are connected in parallel to speakON® poles 1+ and 1-. Not bi-amp capable.

VX 12HP, VX 12Q, VX 12.2Q, VX 15HP, VX 15Q

Inputs on 2 x speakON® 4-pole and 2x barrier strip terminal pair. Both barrier strip terminal pairs are connected in parallel to speakON® poles 1+ and 1- when configured for full range operation. Bi-amp configuration may be implemented using speakON® connectors only. (See 6.0 below.)

Binding post terminals are capable of accepting cables with a conductor of up to 6 mm sq CSA (AWG 10). Red is positive and black is negative.

Barrier strips accept wire up to 4 mm sq CSA (AWG 12). Barrier strip polarity is as indicated.

The speakON® connectors will accept wire up to 4 mm sq CSA (AWG 12) with an outside diameter of up to 15 mm and a current rating of 30 A. When so equipped, the pins of the two speakON® sockets identified input/output on the rear of the input panel are paralleled within the enclosure. Tannoy have adopted the conventional wiring standard for the VX Series product: pin 1+ is positive pin 1- is negative. For a worldwide list of Neutrik® distributors see www.neutrik.com.

When choosing cable type, it is important select the correct cross sectional area in relation to the cable length and the load impedance. A small cross sectional area will increase the cable's series resistance, inducing power loss and response variations (damping factor). Connectors wired with 2.5 sq. mm (12 gauge) cable will be satisfactory under normal conditions; with very long cable runs, the wire size should be increased. Please refer to the following table for guidance:

Cable run (m)	C.S.A of Each Conductor	Cable resistance (ohms)	% Power loss into 8 ohms load	% Power loss into 4 ohms load
10	2.5	0.14	1.7	3.5
	4.0	0.09	1.1	2.2
	6.0	0.06	0.73	1.5
25	2.5	0.14	1.7	3.5
	4.0	0.09	1.1	2.2
	6.0	0.06	0.73	1.5
50	2.5	0.14	1.7	3.5
	4.0	0.09	1.1	2.2
	6.0	0.06	0.73	1.5
100	2.5	0.14	1.7	3.5
	4.0	0.09	1.1	2.2
	6.0	0.06	0.73	1.5

4. Polarity Checking

Checking the polarity of the wiring before the speaker system is mounted or flown will help ensure satisfactory performance. If you do not have a pulse based polarity checker, you may check LF units as follows: Connect two wires to the + and - terminals of a PP3 (9 V) battery. Apply the wire connected to the positive (+) terminal of the battery to the speaker cable leg which you believe to be connected to pin 1+ of the speaker connector; likewise connect the negative (-) terminal of the battery to pin 1-. If you have wired it correctly, the LF drive unit will move forward. At this point, connect the positive (+) speaker lead to the + terminal on the amplifier and the negative (-) lead to the - terminal on the amplifier. However, if the LF driver moves backwards with the battery test, the input connections need to be inverted before connecting the amplifier. If problems are encountered, inspect the cable wiring. Note that different amplifier manufacturers may utilise different pin configurations and polarity conventions; if you are using amplifiers from more than one manufacturer, check the polarity at the amplifiers as well as at the loudspeakers.

5. Amplification & Power Handling

As with all professional loudspeaker systems, the power handling is a function of voice coil thermal capacity. Care should be taken to avoid overdriving the amplifier into clipping. Damage to the loudspeaker will be sustained if the amplifier is driven into clipping for any extended period of time. Headroom of at least 3 dB should be allowed.

When evaluating an amplifier, it is important to take into account its behaviour under low impedance load conditions. A loudspeaker system is highly reactive, and with transient signals it can require more current than the nominal impedance would indicate. Generally a higher power amplifier running free of distortion will do less damage to the loudspeaker than a lower power amplifier that is continually clipping. A high-powered amplifier running at less than 90% of output power generally sounds superior to a lower power amplifier running at 100%. An amplifier with insufficient drive capability will not allow the full performance or the loudspeaker to be realised. (See technical specifications section for recommended amplifier power.)

When using amplifiers from different manufacturers in a single installation, make certain that all have very closely matched gains. (Variation should be less than +/- 0.5 dB.) This precaution is important to the overall system balance when only a single active crossover is being used with multiple cabinets. When possible, it is recommended that the same amplifiers be used throughout.

6. Crossovers and Bi-amp Configuration

VX Series loudspeakers are supplied as standard for passive operation via the internal crossover network. If higher peak outputs and additional low frequency output is required, then the VX Series can be used in conjunction with the Tannoy TX1 controller/crossover which provides high pass filtering and a degree of parametric equalisation, as well as a fixed crossover point for use with sub-bass loudspeakers (See the TX1 Operation Manual for further information.) The Tannoy TDX2 Digital controller will also perform the above functions with additional control and features including limiting and delay. (See the relevant literature on the TDX2 for further information.)

The VX 12HP, VX 12Q, VX 12.2Q, VX 15HP, VX 15Q only also may be internally reconfigured for bi-amp operation to supply greater system headroom. Reconfiguration is as follows.

First, remove the rear termination panel. It is secured with size M2.5 hex screws. Use the proper tool as screws may be very snug.

In passive (default) mode, the internal wiring is as shown in Fig. 1, with the full range signal routed through the internal crossover and divided into separate LF and HF signals using a four pole connector.

For bi-amp operation, reconfigure the internal wiring as shown in Fig 2. The two-wire connector leading to the crossover is disconnected. The four-wire connector from the speakers now bypasses the crossover and instead connects directly to the speakON® inputs, replacing the connector that previously led to the crossover.

For bi-amp operation, the speakON® connectors coming from the amplifier(s) must be wired as follows:

1 +	LF +
1 -	LF -
2 +	HF +
2 -	HF -

Note that the barrier strip terminals are wired for passive full-range operation only.

Fig 1.

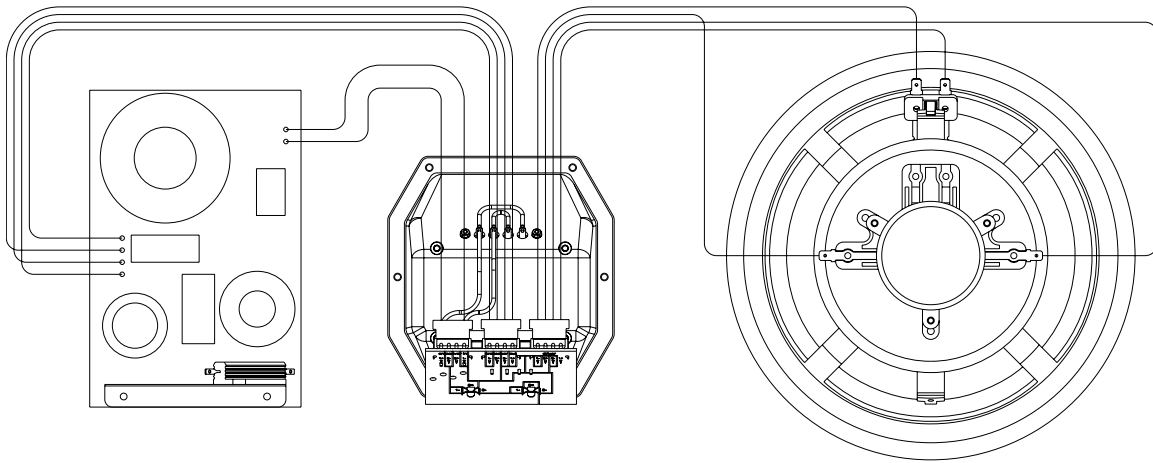
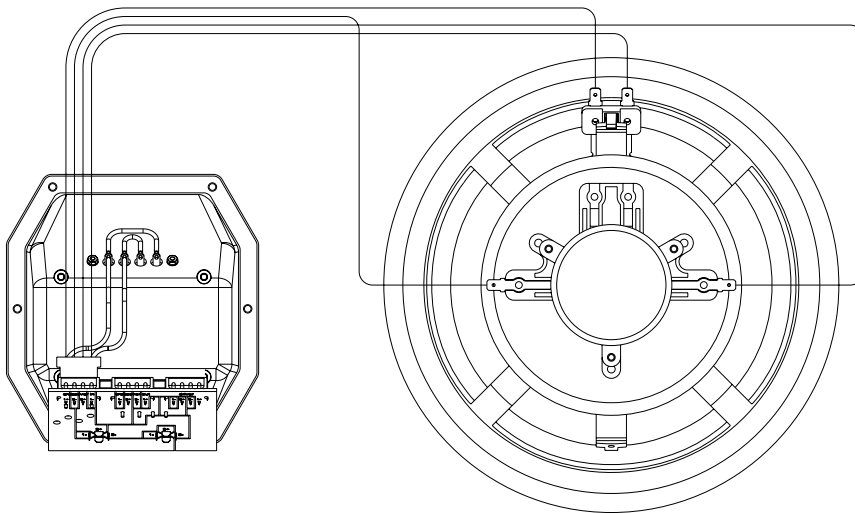

Fig 2.



7. Equalisation

VX Series loudspeakers require no equalisation or correction to overcome system limitations; equalisation is necessary only to compensate for difficult acoustic environments. Over-equalisation can reduce system headroom and introduce phase distortion, resulting in degraded sound. If equalisation is required, it should be applied gently and smoothly. Because VX Series loudspeakers are point source, phase coherent designs, excessive equalization usually proves detrimental to the overall sound quality.

When one loudspeaker is used in close proximity to another, comb filtering effects can create coverage problems. (Comb filtering creates an uneven frequency response across the coverage area due to constructive and destructive interference effects between the two sources.) Comb filtering cannot be cured by equalisation; this should be addressed with proper arraying as discussed in the following section.

8. Arraying

Small alterations to loudspeaker positions can have the effect of minimising problematic combing frequencies. Arrays should be constructed so that the individual coverage patterns of each loudspeaker combine with minimal overlap. The design of the VXP cabinet greatly simplifies the creation of effective arrays, allowing seamless wide horizontal coverage using two loudspeakers without the need for tedious experimentation.

By placing the VXP cabinets with the 30 degree angled rear panels together, minimal dispersion pattern overlap is achieved, guaranteeing an extraordinarily smooth transition. In many applications the 90 or 75 degree dispersion pattern may be sufficient in the horizontal plane. It is also possible to stack the cabinets vertically using the above method (in a central cluster for example) where greater vertical dispersion is required. As shown in the above diagram, one of the VXP cabinets is inverted to allow the optimum splay angle to be achieved. The grille can be simply removed from this cabinet and be replaced for matching orientation. The grille is held in position by the two fixing screws on the top and bottom lips of the cabinet.

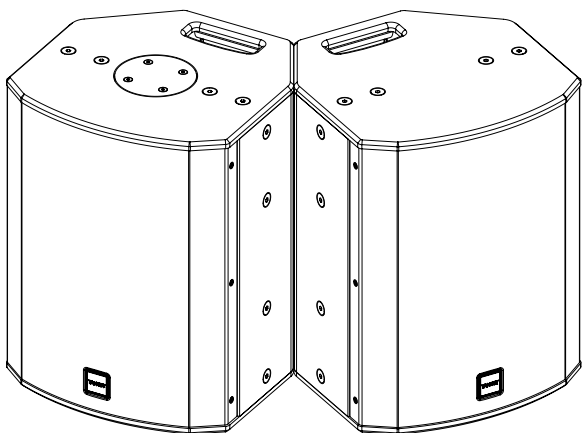

9. Dimensions

VX 5.2

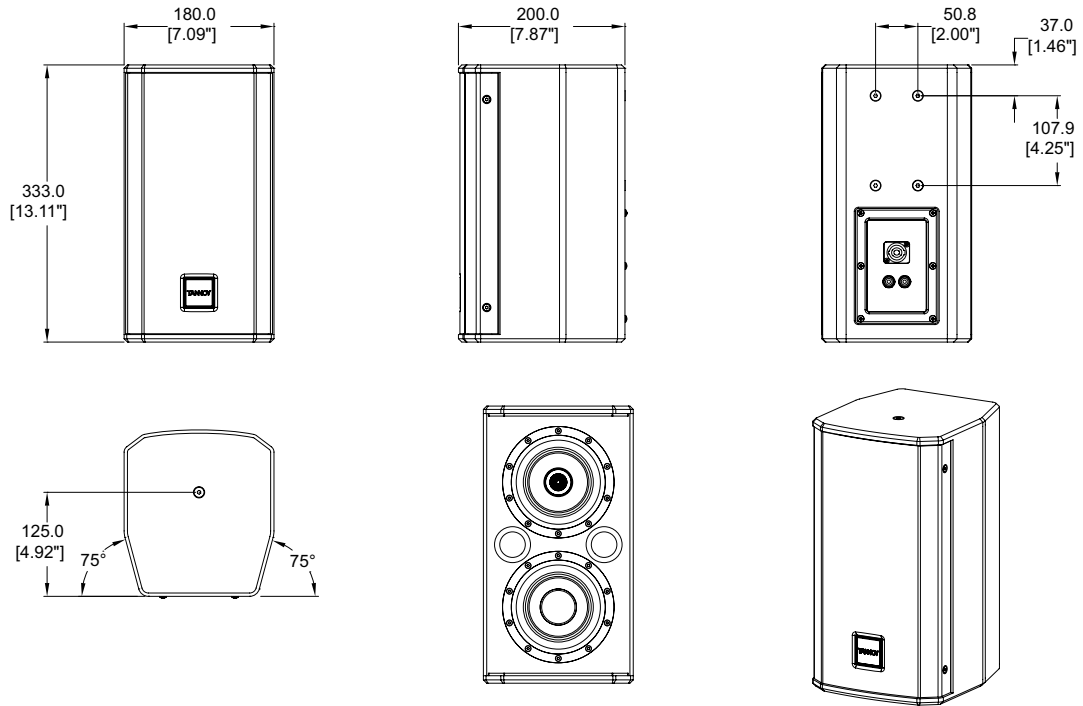

VX 6

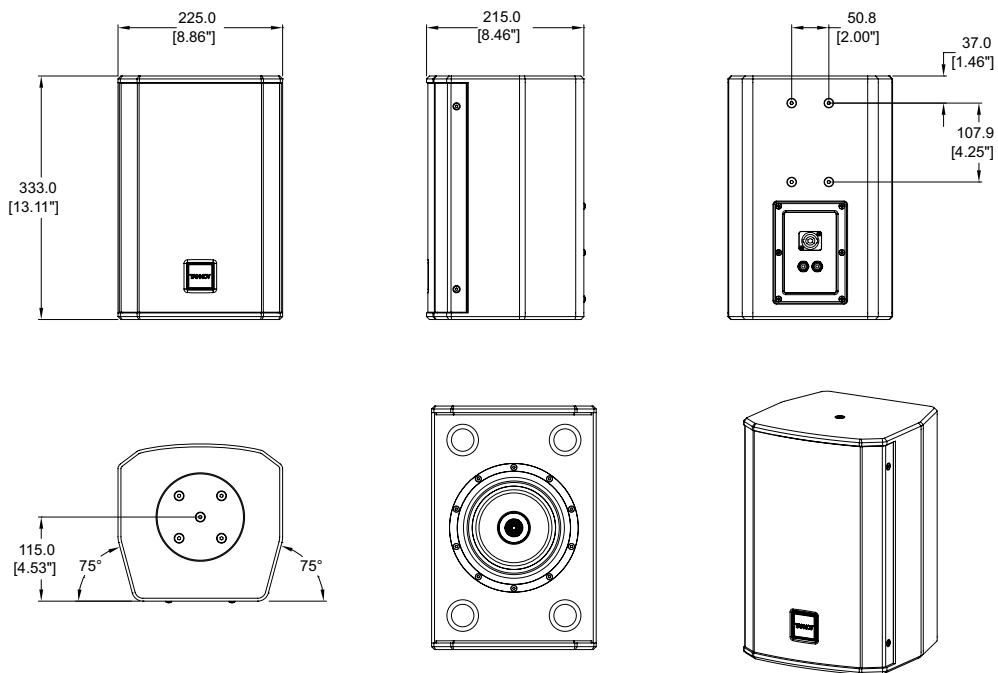

VX 8

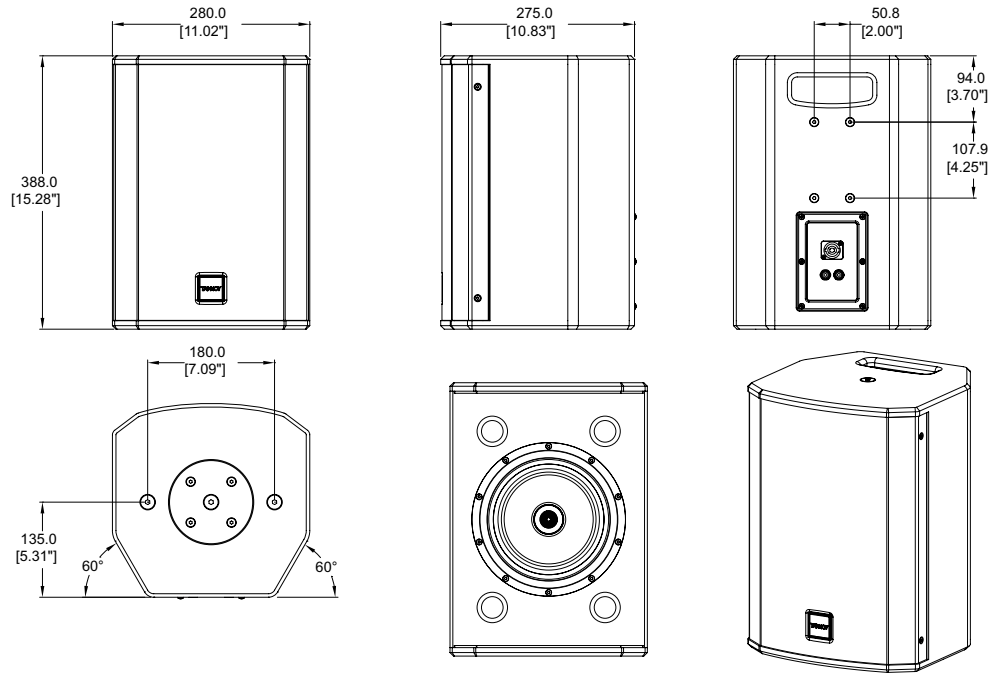

VX 8M

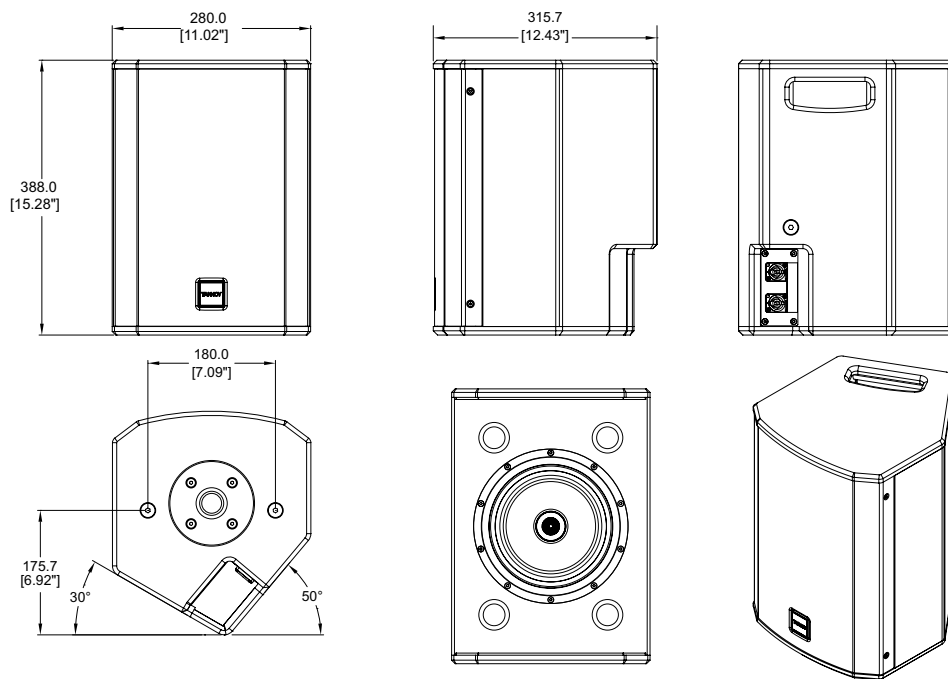

VX 8.2

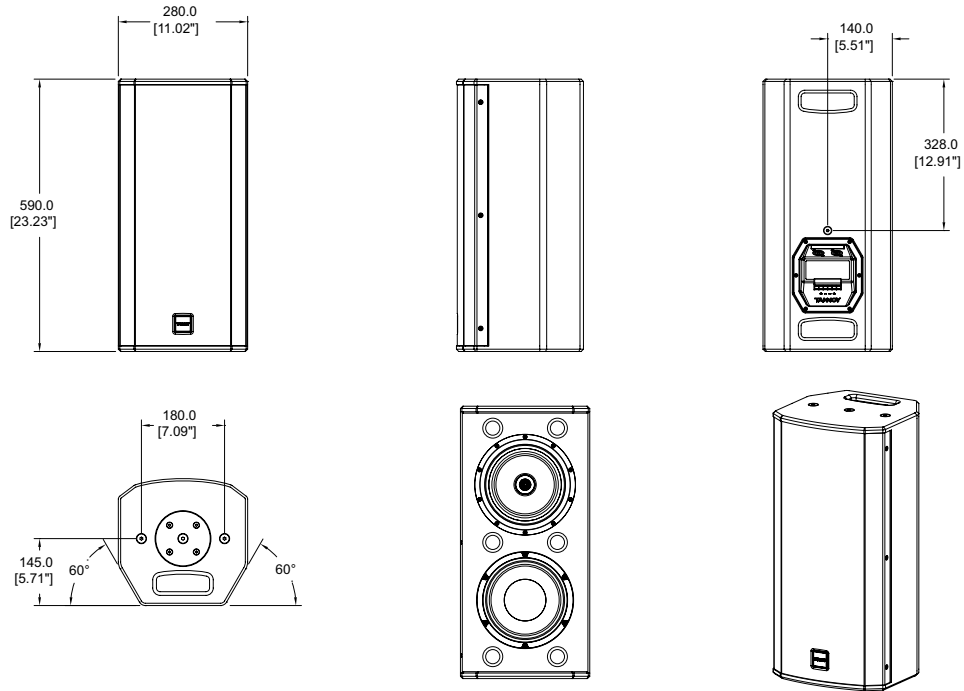

VX 12

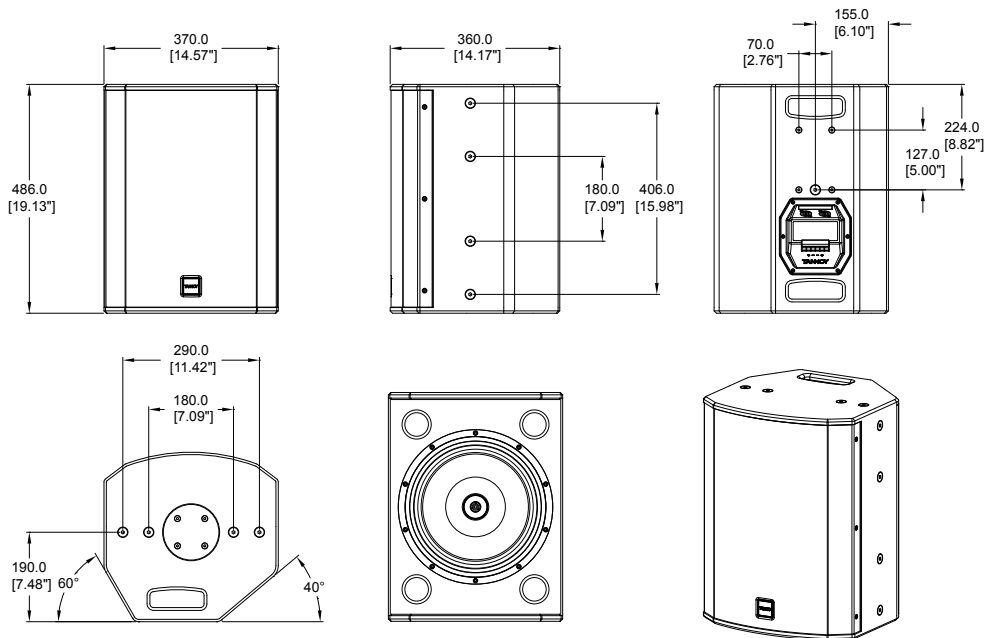

VX 12HP

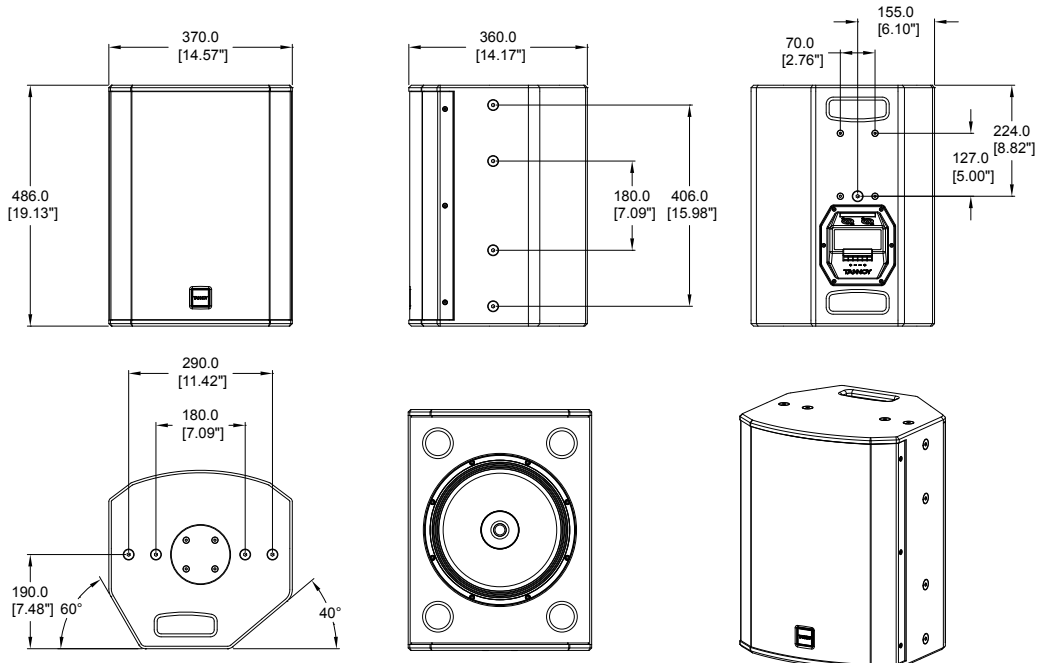

VX 12Q

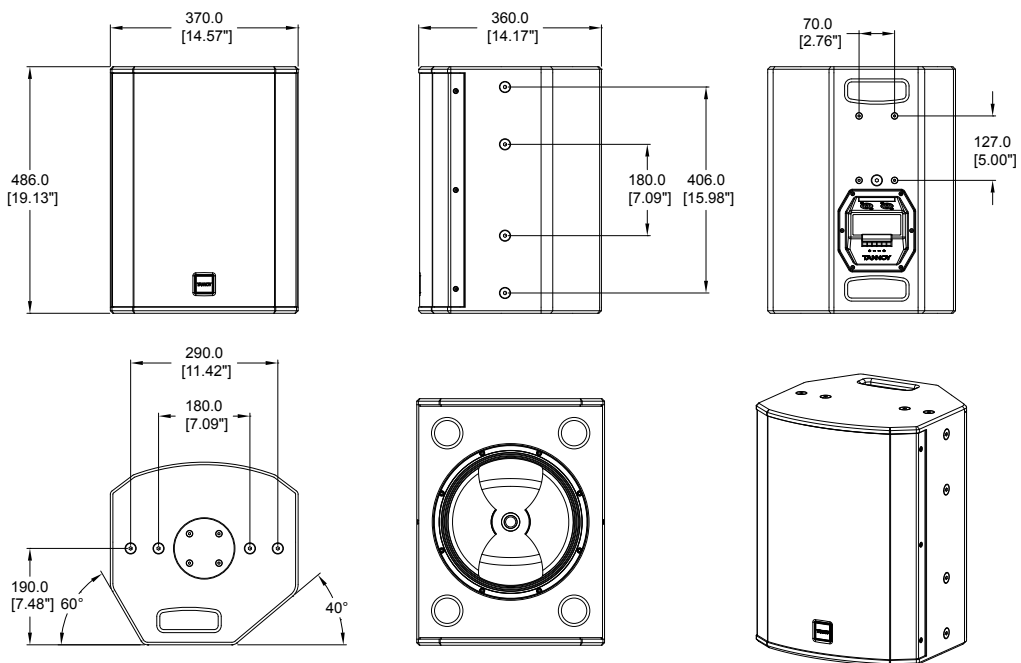

VX 12.2Q

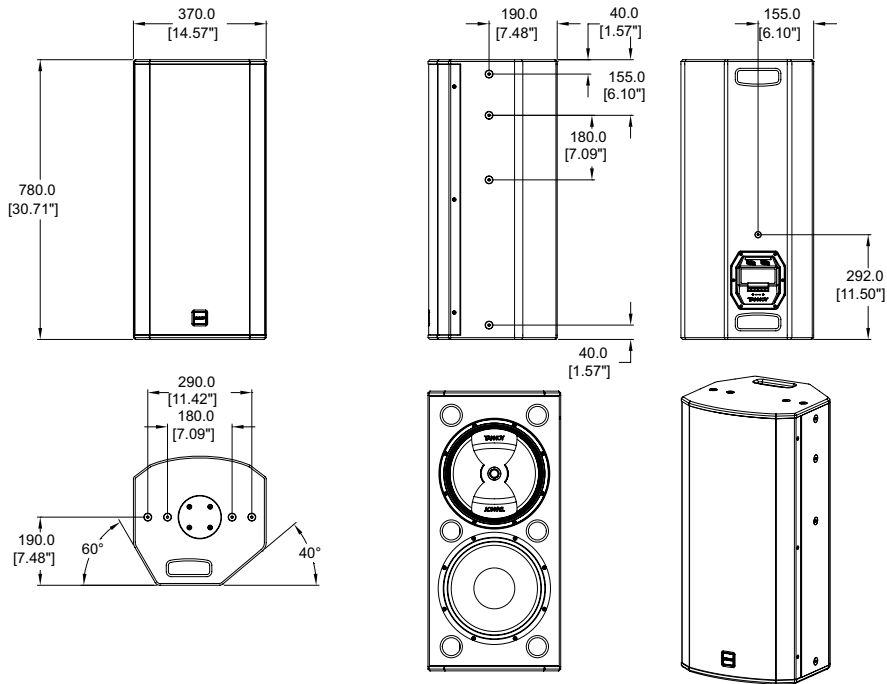

VX 15HP

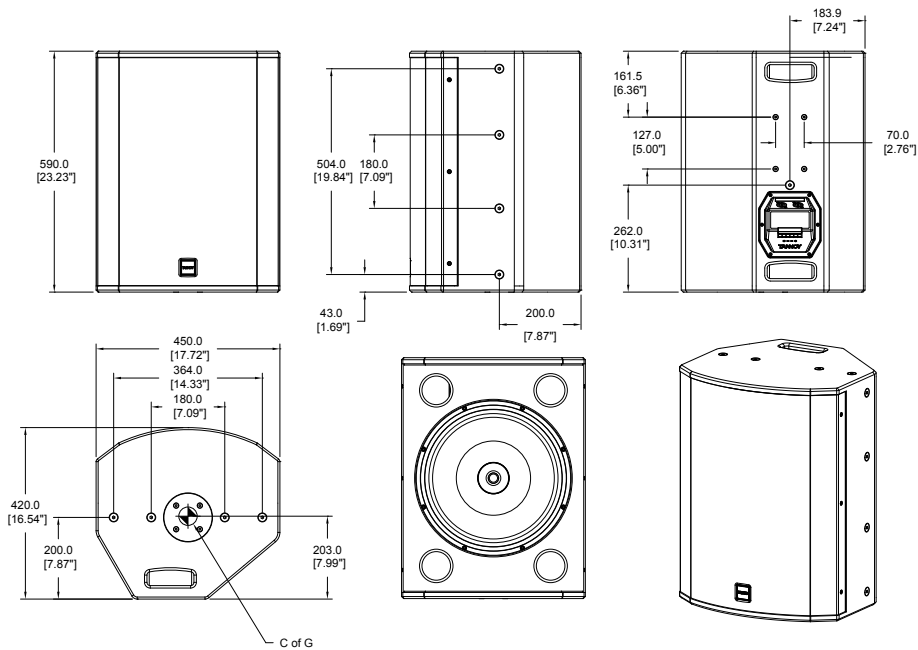

VX15Q

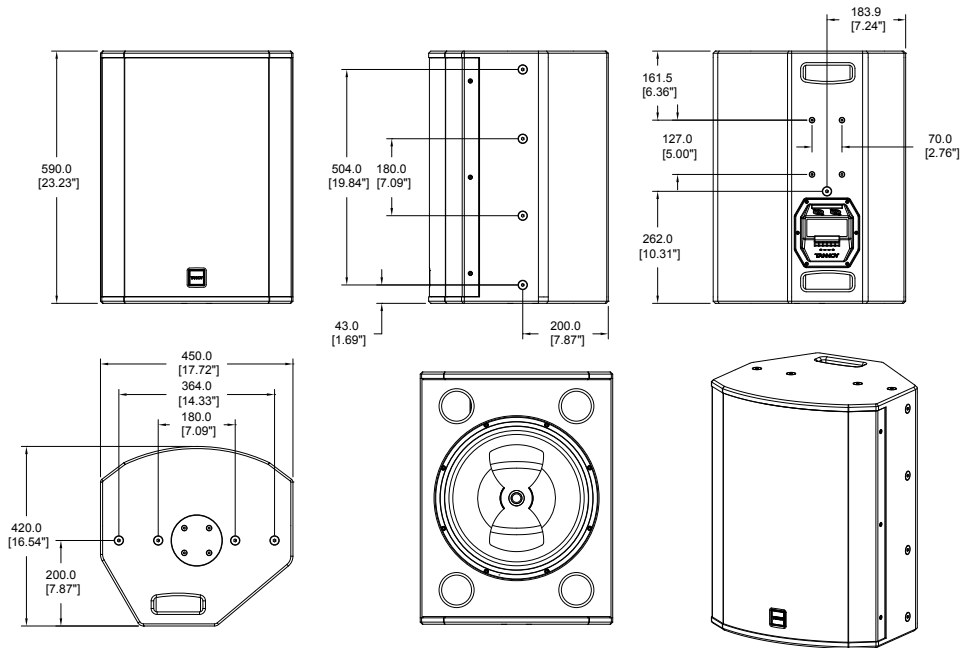

10. Rigging and Safety Procedures

The Tannoy Professional hardware covered in this guide has been designed to offer quick, simple, cost effective and secure solutions for mounting specific Tannoy Professional loudspeakers. This hardware has been designed and manufactured with a high safety load factor for its specific role. To ensure the safest possible use of the hardware covered in this guide, it must be assembled in strict accordance with the instructions specified. The information in these Operation Manuals relating to the assembly and the safe use of these accessories must be understood and followed.

The installation of Tannoy Professional loudspeakers - using the dedicated hardware - should be carried out only by fully qualified installers, in accordance with all the required safety codes and standards that apply at the place of installation. **WARNING:** As the legal requirements for mounting, suspending, hanging, flying or rigging equipment change from country to country, please consult your local safety standards office before installing any product. We also recommend that you thoroughly check any laws and bylaws prior to installation.

Tannoy Professional hardware has been designed for use with specific Tannoy Professional loudspeakers, and is not designed or intended for use with any other Tannoy Professional products, or any other devices. Using Tannoy Professional hardware for any purpose other than that indicated in this guide is considered to be improper use. Such use can be very dangerous: overloading, modifying, damaging, or assembling in a manner other than that clearly stated in the Operation Manual will compromise safety. The component parts of any Tannoy Professional hardware device must only be assembled using the accessory kits supplied and in strict compliance with the Operation Manual. The use of other accessories or non-approved methods of assembly may result in an unsafe hardware system by reducing the load safety factor. Welding, or any other method of permanently fixing hardware components together or to the integral fixing points in the cabinet, should never be used.

Whenever a Tannoy Professional loudspeaker is fixed to a surface using a Tannoy Professional hardware device, the installer must ensure that the surface is capable of safely and securely supporting the load. The hardware employed must be safely, and securely attached both to the loudspeaker and also to the surface in question, in accordance with the Operation Manual, using only the fixing holes provided as standard and covered in the manual. Secure fixings to the building structure are vital. Seek help from architects, structural engineers or other specialists if in any doubt. All loudspeakers flown in theatres, nightclubs, conference centres or other places of work and entertainment must be provided with an independent, correctly rated and securely attached secondary safety restraint in addition to the principal hardware device. This secondary safety restraint must prevent the loudspeaker from dropping more than 150 mm (6") should the principal hardware device fail.

11. Service Parts & Accessories

Model	HF unit	Dual driver	Bass driver	HF diaphragm	Recone Kit
VX 5.2	7900 0915	7900 1280	7900 1281	-	-
VX 6	7900 0683	7900 0742	-	-	-
VX 8	-	7900 1282	-	7900 1284	-
VX 8M	-	7900 1282	-	7900 1284	-
VX 8.2	-	7900 1282	7900 1283	7900 1284	-
VX 12	-	7900 1285	-	7900 1287	7900 0441
VX 12HP	-	7900 1289*/ 7900 1366	-	7900 1292	7900 0716*/ 7900 1358
VX 12Q	-	7900 1290*/ 7900 1364	-	7900 1292	7900 0716*/ 7900 1358
VX 12.2Q	-	7900 1290*/ 7900 1364	7900 1291	7900 1292	7900 0716*/ 7900 1358
VX 15HP	-	7900 1293*/ 7900 1367	-	7900 1292	7900 0646*/ 7900 1359
VX 15Q	-	7900 1294*/ 7900 1367	-	7900 1292	7900 0646*/ 7900 1359

* Pre July 2013

12. Technical Specifications

Following are the VX Series technical specifications. These figures are accurate at the time of printing but please note that all figures are subject to change without notice.

Model	VX 5.2	VX 6	VX 8
Performance			
Frequency Response (-3 dB) ⁽¹⁾	87 Hz – 35 Hz	92 Hz – 35 Hz	85 Hz – 35 Hz
Frequency Range (-10 dB) 1	65 Hz – 45kHz	80 Hz – 45kHz	62 Hz – 45 kHz
System Sensitivity (1 W @1 m) ⁽²⁾	90 dB (1 W = 2.83 V for 8 ohms)	91 dB (1 W = 2.83 V for 8 ohms)	92 dB (1 W = 2.83 V for 8 ohms)
Dispersion (degrees conical)	120 degrees (H) x 90 degrees (V)	90 degrees conical	90 degrees conical
Driver Complement	1 x 125 mm (5.00") constant directivity Dual Concentric 1 x 125mm (5.00") bass driver	1 x 150 mm (6.00") constant directivity Dual Concentric	1 x 200 mm (8.00") constant directivity Dual Concentric
Crossover	Passive 2.0 kHz with dynamic HF protection	Passive 2.0 kHz with dynamic HF protection	Passive 1.7 kHz with dynamic HF protection
Directivity Factor (Q)	7.3 (averaged 1 kHz to 8 kHz)	5.6 (averaged 1 kHz to 10 kHz)	6.8 (averaged 1 kHz to 10 kHz)
Directivity Index (DI)	8.6 (averaged 1 kHz to 8 kHz)	7.0 (averaged 1 kHz to 10 kHz)	7.9 (averaged 1 kHz to 10 kHz)
Rated Maximum SPL (2)	Average: 111 dB Peak: 117 dB	Average: 111 dB Peak: 117 dB	Average: 113 dB Peak: 119 dB
Power Handling	Average: 130 W Programme: 260 W Peak: 520 W	Average: 100 W Programme: 200 W Peak: 400 W	Average: 130 W Programme: 260 W Peak: 520 W
Recommended Amplifier Power	260 W @ 8 ohms	200 W @ 8 ohms	260 W @ 8 ohms
Nominal Impedance	8 ohms	8 ohms	8 ohms
Distortion			
10% Full Power (10.2 V)	2nd Harmonic 3rd Harmonic	2nd Harmonic 3rd Harmonic	2nd Harmonic 3rd Harmonic
250 Hz	2.85% 0.52%	2.64% 0.365%	0.12% 0.15%
1 kHz	0.56% 0.31%	0.223% 0.458%	0.23% 0.84%
10 kHz	1.24% 0.15%	1.873% 0.29%	1.35% 0.16%
Distortion			
10% Full Power (10.2 V)	2nd Harmonic 3rd Harmonic	2nd Harmonic 3rd Harmonic	2nd Harmonic 3rd Harmonic
250 Hz	0.70% 0.17%	0.64% 0.314%	0.16% 0.14%
1 kHz	0.08% 0.26%	0.062% 0.436%	0.09% 0.53%
10 kHz	0.41% 0.10%	0.78% 0.266%	0.53% 0.17%
Construction			
Enclosure	6.73 litre birch plywood, vented and internally brace	9.16 litre birch plywood, vented and internally brace	16.28 litre, 15 mm (0.62") birch plywood, vented and internally braced.
Finish	Textured black or white paint, with custom colours on request. Powder coated perforated steel grille Airmet cloth behind	Textured black or white paint, with custom colours on request. Powder coated perforated steel grille Airmet cloth behind	Textured black or white paint, with custom colours on request. Powder coated perforated steel grille Airmet cloth behind
Connectors	1 x speakON NL4MP, 2 x 4 mm binding posts	1 x speakON NL4MP, 2 x 4 mm binding posts	1 x speakON NL4MP, 2 x 4 mm binding posts
Fittings	2 x M6 yoke bracket inserts (4mm allen key), Fixings compatible with Omnimount and Powerdrive style brackets, 4 x M6 inserts	2 x M6 yoke bracket inserts (4mm allen key), Fixings compatible with Omnimount and Powerdrive style brackets, 4 x M6 inserts, Blanking plate for optional VTH pole mount	2 x M10 yoke bracket inserts (6mm allen key), 2 x M10 flying inserts, Fixings compatible with Omnimount and Powerdrive style brackets, 4 x M6 inserts, Blanking plate for optional VTH pole mount, 1 x Integrip carrying handle
Dimensions (H x W x D)	W: 180 mm (7.1"), H: 333 mm (13.1"), D: 200 mm (7.9")	W: 225 mm (8.9"), H: 333 mm (13.1"), D: 215 mm (8.1")	W: 280 mm (11.0"), H: 388 mm (15.3"), D: 275 mm (10.8")
Net Weight	5.0 kg (11.0 lbs)	5.5 kg (12.1 lbs)	8.5 kg (18.7 lbs)
Shipped Weight	10.5 kg (23.1 lbs)	12.5 kg (27.6 lbs)	18.5 kg (40.8 lbs)
Packed Quantity	2	2	2

(1) Average over stated bandwidth. Measured at 1 metre on axis in an anechoic chamber.

(2) Unweighted pink noise input, measured at 1 metre in an anechoic chamber.

A full range of measurements, performance data, and Ease™ Data can be downloaded from www.tannoy.com.

Tannoy operates with a policy of continuous research and development. Product performance always will equal or exceed published specifications. However, following introduction of new materials or manufacturing methods, Tannoy reserves the right to alter specifications without prior notice.

Model	VX 8M	VX 8.2	VX 12
Performance			
Frequency Response (-3 dB) ¹⁾	85 Hz – 35 Hz	80 Hz – 35 Hz	70 Hz – 25 Hz
Frequency Range (-10 dB) 1	62 Hz – 45 kHz	60 Hz – 45 kHz	55 Hz – 38 kHz
System Sensitivity (1 W @1 m) ²⁾	92 dB (1 W = 2.83 V for 8 ohms)	93 dB (1 W = 2.83 V for 8 ohms)	97 dB (1 W = 2.83 V for 8 ohms)
Dispersion (degrees conical)	90 degrees conical	90 degrees conical	90 degrees conical
Driver Complement	1 x 200 mm (8.00") constant directivity Dual Concentric	1 x 200 mm (8.00") constant directivity Dual Concentric 1 x 200mm (8.00") bass driver	1 x 305 mm (12.00") constant directivity Dual Concentric
Crossover	Passive 1.7 kHz with dynamic HF protection	Passive 360 Hz and 1.5 kHz with dynamic HF protection	Passive 1 kHz with HF protection
Directivity Factor (Q)	6.8 (averaged 1 kHz to 8 kHz)	8.1 (averaged 1 kHz to 8 kHz)	9.6 (averaged 1 kHz to 8 kHz)
Directivity Index (DI)	9.2 (averaged 1 kHz to 8 kHz)	9.2 (averaged 1 kHz to 8 kHz)	9.8 (averaged 1 kHz to 8 kHz)
Rated Maximum SPL (2)	Average: 113 dB Peak: 119 dB	Average: 116 dB Peak: 122 dB	Average: 120 dB Peak: 126 dB
Power Handling	Average: 130 W Programme: 260 W Peak: 520 W	Average: 200 W Programme: 400 W Peak: 800 W	Average: 200 W Programme: 400 W Peak: 800 W
Recommended Amplifier Power	260 W @ 8 ohms	400 W @ 8 ohms	400 W @ 8 ohms
Nominal Impedance	8 ohms	8 ohms	8 ohms
Distortion			
10% Full Power (10.2 V)	2nd Harmonic 3rd Harmonic	2nd Harmonic 3rd Harmonic	2nd Harmonic 3rd Harmonic
250 Hz	0.12% 0.15%	0.58% 0.34%	0.52% 0.58%
1 kHz	0.23% 0.84%	0.34% 0.69%	2.98% 0.63%
10 kHz	1.35% 0.16%	1.73% 0.15%	3.58% 0.19%
Distortion			
10% Full Power (10.2 V)	2nd Harmonic 3rd Harmonic	2nd Harmonic 3rd Harmonic	2nd Harmonic 3rd Harmonic
250 Hz	0.16% 0.14%	0.15% 0.15%	0.10% 0.26%
1 kHz	0.09% 0.53%	0.11% 0.37%	0.81% 0.58%
10 kHz	0.53% 0.17%	0.74% 0.22%	1.18% 0.03%
Construction			
Enclosure	16.28 litre, 15 mm (0.62") birch plywood, vented and internally braced.	24.97 litre, 15 mm (0.62") birch plywood, vented and internally braced.	36.07 litre, 15 mm (enclosure) and 18 mm (front) birch plywood vented and internally braced
Finish	Textured black or white paint, with custom colours on request. Powder coated perforated steel grille Airmet cloth behind	Textured black or white paint, with custom colours on request. Powder coated perforated steel grille Airmet cloth behind	Textured black or white paint, with custom colours on request. Powder coated perforated steel grille Airmet cloth behind
Connectors	2 x speakON NL4MP	2 x speakON NL4MP and Barrier strip	2 x speakON NL4MP and Barrier strip
Fittings	3 x M10 flying inserts (portrait mounting), 1 x Integrip carrying handle, Integral Pole Mount for standard 35mm poles	4 x M10 Flying inserts, 2 x M10 yoke bracket inserts 2 x Integrip carrying handles Blanking plate for optional VTH pole mount	8 x M10 Flying inserts (portrait or landscape mounting), 8 x M10 yoke bracket inserts, 2 x Integrip carrying handles, Blanking plate for optional VTH pole mount, Fixings compatible with Powerdrive™ style brackets, 4 x M6 inserts
Dimensions (H x W x D)	W: 280 mm (11.0"), H: 388 mm (15.3"), D: 315.7 mm (12.4")	W: 280 mm (11.0"), H: 590 mm (23.2"), D: 275 mm (10.8")	W: 370 mm (14.6"), H: 486 mm (19.1"), D: 360 mm (14.1")
Net Weight	9 kg (19.8 lbs)	15.5 kg (34.2 lbs)	17.0 kg (37.5 lbs)
Shipped Weight	20 kg (44.1 lbs)	17.5 kg (38.6 lbs)	19.5 kg (43.0 lbs)
Packed Quantity	2	1	1

(1) Average over stated bandwidth. Measured at 1 metre on axis in an anechoic chamber.

(2) Unweighted pink noise input, measured at 1 metre in an anechoic chamber.

A full range of measurements, performance data, and Ease™ Data can be downloaded from www.tannoy.com.

Tannoy operates with a policy of continuous research and development. Product performance always will equal or exceed published specifications. However, following introduction of new materials or manufacturing methods, Tannoy reserves the right to alter specifications without prior notice.

12. Technical Specifications

Model	VX 12HP	VX 12Q	VX 12.2Q
Performance			
Frequency Response (-3 dB) ¹⁾	80 Hz – 25 Hz	80 Hz – 25 Hz	70 Hz – 25 Hz
Frequency Range (-10 dB) 1	60 Hz – 30 kHz	60 Hz – 30 kHz	55 Hz – 30 kHz
System Sensitivity (1 W @1 m) ²⁾			
Passive - Full Range	97 dB (1W = 2.83 V for 8 ohms)	97 dB (1W = 2.83 V for 8 ohms)	99 dB (1W = 2.83 V for 8 Ohms)
Biamp (LF)	98 dB	98 dB	98 dB
Biamp (LF)	106 dB	108 dB	102 dB
Dispersion (degrees conical)	75 degrees conical	75 degrees (H) x 40 degrees (V)	75 degrees (H) x 40 degrees (V)
Driver Complement	1 x 305 mm (12.00") constant directivity PowerDual™	1 x 305 mm (12.00") PowerDual™ with Q-Centric waveguide	1 x 305 mm (12.00") PowerDual™ with Q-Centric waveguide 1 x 305 mm (12.00") bass driver
Crossover	Passive 1 kHz Product can be reconfigured for bi-amped operation. Bi-amp system parameters in Operation Manual	Passive 1.5 kHz Product can be reconfigured for bi-amped operation. Bi-amp system parameters in Operation Manual	Passive 300 Hz and 1.5 kHz Product can be reconfigured for bi-amped operation. Bi-amp system parameters in Operation Manual
Directivity Factor (Q)	10.1 (averaged 1 kHz to 10 kHz)	13.0 (averaged 1 kHz to 8 kHz)	13.0 (averaged 1 kHz to 8 kHz)
Directivity Index (DI)	10.0 (averaged 1 kHz to 10kHz)	11.1 (averaged 1 kHz to 8 kHz)	11.1 (averaged 1 kHz to 8 kHz)
Rated Maximum SPL (2)			
Passive - Full Range	123 dB (average) 129 dB (peak)	123 dB (average) 129 dB (peak)	126 dB (average) 132 dB (peak)
Biamp (LF)	124 dB (average) 130 dB (peak)	124 dB (average) 130 dB (peak)	123 dB (average) 129 dB (peak)
Biamp (HF)	125 dB (average) 131 dB (peak)	127 dB (average) 132 dB (peak)	127 dB (average) 133 dB (peak)
Power Handling			
Passive - Full Range	Average: 350 W Programme: 700 W Peak: 1400 W	Average: 350 W Programme: 700 W Peak: 1400 W	Average: 500 W Programme: 1000 W Peak: 2000 W
Biamp (LF)	Average: 350 W Programme: 700 W Peak: 1400 W	Average: 350 W Programme: 700 W Peak: 1400 W	Average: 350 W Programme: 700 W Peak: 1400 W
Biamp (HF)	Average: 80 W Programme: 160 W Peak: 320 W	Average: 80 W Programme: 160 W Peak: 320 W	Average: 350 W Programme: 700 W Peak: 1400 W
Recommended Amplifier Power			
Passive - Full Range	700 W @ 8 ohms	700 W @ 8 ohms	1000 W @ 8 ohms
Biamp (LF)	700 W @ 8 ohms	700 W @ 8 ohms	700 W @ 8 ohms
Biamp (HF)	160 W @ 8 ohms	160 W @ 8 ohms	700 W @ 8 ohms
Nominal Impedance	8 ohms	8 ohms	8 ohms
Distortion			
10% Full Power (10.2 V)	2nd Harmonic 3rd Harmonic	2nd Harmonic 3rd Harmonic	2nd Harmonic 3rd Harmonic
250 Hz	0.239% 0.67%	0.72% 0.17%	2.49% 0.49%
1 kHz	1.58% 2.53%	0.57% 0.76%	0.54% 0.73%
10 kHz	5.2% 0.161%	5.11% 0.08%	7.54% 0.80%
10% Full Power (10.2 V)	2nd Harmonic 3rd Harmonic	2nd Harmonic 3rd Harmonic	2nd Harmonic 3rd Harmonic
250 Hz	0.11% 0.581%	0.16% 0.19%	0.60% 0.21%
1 kHz	0.79% 2.53%	0.18% 0.49%	0.20% 0.49%
10 kHz	1.94% 0.161%	1.63% 0.08%	2.56% 0.10%
Construction			
Enclosure	36.07 litre, 15 mm (enclosure) and 18 mm (front) birch plywood, vented and internally braced	36.07 litre, 15 mm (enclosure) and 18 mm (front) birch plywood, vented and internally braced	59.08 litre, 15 mm (enclosure) and 18 mm (front) birch plywood, vented and internally braced
Finish	Textured black or white paint, with custom colours on request. Powder coated perforated steel grille Airmet cloth behind	Textured black or white paint, with custom colours on request. Powder coated perforated steel grille Airmet cloth behind	Textured black or white paint, with custom colours on request. Powder coated perforated steel grille Airmet cloth behind
Connectors	2 x speakON NL4MP and Barrier strip	2 x speakON NL4MP and Barrier strip	2 x speakON NL4MP and Barrier strip
Fittings	8 x M10 Flying inserts (portrait or landscape mounting), 8 x M10 yoke bracket inserts, 2 x Integrip carrying handles, Blanking plate for optional VTH pole mount, Fixings compatible with Powerdrive™ style brackets, 4 x M6 inserts	8 x M10 Flying inserts (portrait or landscape mounting), 8 x M10 yoke bracket inserts, 2 x Integrip carrying handles, Blanking plate for optional VTH pole mount, Fixings compatible with Powerdrive™ style brackets, 4 x M6 inserts	8 x M10 Flying inserts (portrait or landscape mounting), 8 x M10 yoke bracket inserts, 2 x Integrip carrying handles, Blanking plate for optional VTH pole mount
Dimensions (H x W x D)	W: 370 mm (14.6"), H: 486 mm (19.1"), D: 360 mm (14.1")	W: 370 mm (14.6"), H: 486 mm (19.1"), D: 360 mm (14.1")	W: 370 mm (14.6"), H: 780 mm (30.7"), D: 360 mm (14.1")
Net Weight	21.5 kg (47.4 lbs)	21.0 kg (46.3 lbs)	33.5 kg (73.9 lbs)
Shipped Weight	23.5 kg (51.8 lbs)	23.0 kg (50.7 lbs)	36.5 kg (80.5 lbs)
Packed Quantity	1	1	1

(1) Average over stated bandwidth. Measured at 1 metre on axis in an anechoic chamber.

(2) Unweighted pink noise input, measured at 1 metre in an anechoic chamber.

A full range of measurements, performance data, and Ease™ Data can be downloaded from www.tannoy.com.

Tannoy operates with a policy of continuous research and development. Product performance always will equal or exceed published specifications. However, following introduction of new materials or manufacturing methods, Tannoy reserves the right to alter specifications without prior notice.

Model	VX 15HP	VX 15Q
Performance		
Frequency Response (-3 dB) ¹⁾	70 Hz – 25 Hz	70 Hz – 25 Hz
Frequency Range (-10 dB) 1	58 Hz – 30 kHz	58 Hz – 30 kHz
System Sensitivity (1 W @1 m) ²⁾		
Passive - Full Range	99 dB (1 W = 2.83 V for 8 ohms)	99 dB (1W = 2.83 V for 8 ohms)
Biamp (LF)	100 dB	100 dB
Biamp (HF)	106 dB	108 dB
Dispersion (degrees conical)	75 degrees conical	75 degrees (H) x 40 degrees (V)
Driver Complement	1 x 380 mm (15.00") constant directivity PowerDual™	1 x 380 mm (15.00") PowerDual™ with Q-Centric waveguide
Crossover	Passive 1.3 kHz Product can be reconfigured for bi-amped operation. Bi-amp system parameters in Operation Manual	Passive 1.3 kHz Product can be reconfigured for bi-amped operation. Bi-amp system parameters in Operation Manual
Directivity Factor (Q)	9.7 (averaged 1 kHz to 8 kHz)	12.0 (averaged 1 kHz to 8 kHz)
Directivity Index (DI)	9.9 (averaged 1 kHz to 8 kHz)	10.8 (averaged 1 kHz to 8 kHz)
Rated Maximum SPL (2)		
Passive - Full Range	125 dB (average) 131 dB (peak)	125 dB (average) 131 dB (peak)
Biamp (LF)	126 dB (average) 132 dB (peak)	126 dB (average) 132 dB (peak)
Biamp (HF)	125 dB (average) 131 dB (peak)	127 dB (average) 132 dB (peak)
Power Handling		
Passive - Full Range	Average: 400 W Programme: 800 W Peak: 1600 W	Average: 400 W Programme: 800 W Peak: 1600 W
Biamp (LF)	Average: 400 W Programme: 800 W Peak: 1600 W	Average: 400 W Programme: 800 W Peak: 1600 W
Biamp (HF)	Average: 80 W Programme: 160 W Peak: 320 W	Average: 80 W Programme: 160 W Peak: 320 W
Recommended Amplifier Power		
Passive - Full Range	800 W @ 8 ohms	800 W @ 8 ohms
Biamp (LF)	800 W @ 8 ohms	800 W @ 8 ohms
Biamp (HF)	160 W @ 8 ohms	160 W @ 8 ohms
Nominal Impedance	8 ohms	8 ohms
Distortion		
10% Full Power (10.2 V)	2nd Harmonic 3rd Harmonic	2nd Harmonic 3rd Harmonic
250 Hz	1.0% 0.56%	1.05% 0.10%
1 kHz	1.4% 1.0%	1.61% 1.02%
10 kHz	3.9% 1.8%	7.79% 1.15%
10% Full Power (10.2 V)	2nd Harmonic 3rd Harmonic	2nd Harmonic 3rd Harmonic
250 Hz	0.31% 0.45%	0.30% 0.06%
1 kHz	0.45% 0.79%	0.58% 0.52%
10 kHz	3.16% 0.32%	2.32% 0.13%
Construction		
Enclosure	57.82 litre, 18 mm birch plywood, vented and internally braced.	57.82 litre, 18 mm birch plywood, vented and internally braced.
Finish	Textured black or white paint, with custom colours on request. Powder coated perforated steel grille. Airmet cloth behind	Textured black or white paint, with custom colours on request. Powder coated perforated steel grille. Airmet cloth behind
Connectors	2 x speakON NL4MP and Barrier strip	2 x speakON NL4MP and Barrier strip
Fittings	8 x M10 Flying inserts (portrait or landscape mounting), 8 x M10 yoke bracket inserts, 2 x Integrip carrying handles, Blanking plate for optional VTH pole mount, Fixings compatible with Powerdrive™ style brackets, 4 x M6 inserts	8 x M10 Flying inserts (portrait or landscape mounting), 8 x M10 yoke bracket inserts, 2 x Integrip carrying handles, Blanking plate for optional VTH pole mount, Fixings compatible with Powerdrive™ style brackets, 4 x M6 inserts
Dimensions (H x W x D)	W: 450 mm (17.7"), H: 590 mm (23.2"), D: 420 mm (16.5")	W: 450 mm (17.7"), H: 590 mm (23.2"), D: 420 mm (16.5")
Net Weight	26.5 kg (58.4 lbs)	27.0 kg (59.5 lbs)
Shipped Weight	29.5 kg (65.0 lbs)	29.5 kg (65.0 lbs)
Packed Quantity	1	1

(1) Average over stated bandwidth. Measured at 1 metre on axis in an anechoic chamber.

(2) Unweighted pink noise input, measured at 1 metre in an anechoic chamber.

A full range of measurements, performance data, and Ease™ Data can be downloaded from www.tannoy.com.

Tannoy operates with a policy of continuous research and development. Product performance always will equal or exceed published specifications. However, following introduction of new materials or manufacturing methods, Tannoy reserves the right to alter specifications without prior notice.

13. Warranty

No maintenance of the VX Series loudspeakers is necessary.

As part of the MUSIC Group, Tannoy is committed to providing the highest quality products, service and user experience for our customers. One element of this commitment is our after sales support which now incorporates our extended Limited Warranty. In the event of any concern that is not addressed by this extended Limited Warranty we would ask you to contact us at care@music-group.com

For full warranty details including the extended Limited Warranty, please visit <http://www.music-group.com/warranty.aspx> and register your purchase online at www.music-group.com or www.tannoy.com

14. Declaration of Conformity

(in accordance with ISO/IEC 1750-1)

Document No: CE-VX-2

We: Music Group Innovation SC Ltd
Rosehall Industrial Estate, Coatbridge, ML5 4TF, United Kingdom

In accordance with the following Directive(s):

2004/108/RC	Electromagnetic Compatibility (EMC)
2011/65/EU	Restriction of the use of certain hazardous substances (RoHS)

Hereby declare that:

Type of equipment	Professional loudspeakers
Range name	VX
Models	VX 5.2, VX 6, VX 8, VX 8M, VX 8.2, VX 12, VX 12HP, VX 12Q, VX 12.2Q, VX 15HP, VX 15Q

Is/are in conformity with the requirements of the following documents:

Ref. No	Title	Edition
BS EN 55103-1	Electromagnetic compatibility. Product family standard for audio, video, audio-visual and entertainment lighting control apparatus for professional use. Emissions	2009
BS EN 55103-2	Electromagnetic compatibility. Product family standard for audio, video, audio-visual and entertainment lighting control apparatus for professional use. Immunity	2009

Name: Philippe Robineau
Position: Director of Engineering
Done at: Coatbridge
Date: 27/04/2016



Director of Engineering
Tannoy
27 April 2016



tannoypro.com

Tannoy operates a policy of continuous research and development. The introduction of new materials or manufacturing methods will always equal or exceed the published specifications. All specifications are subject to change without notice.
Copyright (c) 2016 Music Group Innovation SC Ltd. All rights reserved.

6481 0592/270416