

# DATA SHEET

## DESONO™

# DX-S8 TWO-WAY HIGH OUTPUT COAXIAL 8-INCH SURFACE MOUNT LOUDSPEAKER



### APPLICATIONS

#### DISTRIBUTED

Bars and Restaurants • Hotels • Casinos  
Shopping Malls • Health and Fitness Clubs  
Houses of Worship • Presentation Spaces  
Sports Facilities • Outdoor Entertainment  
Exhibit Halls • Amusement and Theme Parks

### DESCRIPTION

The Desono™ DX surface mount loudspeakers provide high efficiency, high output, high intelligibility and low distortion in an attractive design. These loudspeakers install quickly and have the same components and voicing as the DX ceiling loudspeakers. The DX surface mount loudspeakers are equipped with a built-in 70 V/100 V autoformer and low impedance input.

For larger installations, the 8" coaxial DX-S8 provides higher sound pressure levels, higher sensitivity and greater bass extension. The DX-S8 also easily outperforms competitive loudspeakers of similar size. With a modern appearance that merges well in most environments, combined with weather-resistant capability suitable for direct outdoor use, the DX-S8 can be used in a wide variety of speech and music applications.

Installation is simple and flexible with Biamp's innovative, patented ClickMount pan-tilt bracket allowing low profile mounting in either vertical or horizontal orientation without moving the bracket position. The power tap switch can be set before the speaker is mounted on the bracket. Models with the U-Bracket are also available for low-profile mounting and include the ClickPlug with an integrated gland nut for weather-resistant applications. Both brackets are theft and tamper resistant.

### FEATURES

- High efficiency, high output, high intelligibility, low distortion
- Uniform coverage from coaxially mounted HF/LF drivers
- Choice of models with ClickMount™ pan-tilt bracket or the U-Bracket makes installation and aiming easy
- Uniform voicing with DX ceiling loudspeakers
- ETL listed, certified to UL 1480A and CSA 62368-1, CE marked, and RoHS compliant

### TECHNICAL SPECIFICATIONS<sup>1</sup>

Operating Mode	Single Amplified with DSP		
Operating Environment	Indoor / Outdoor Direct Exposure		
Operating Range (-10dB) <sup>2</sup>	62 Hz to 18 kHz		
Nominal Beamwidth (H x V)	110° x 110°		
Transducers	LF 1 x 8" (203 mm) HF 1 x 1.25" (32 mm) exit compression driver		
Sensitivity <sup>3</sup>	95 dB (2.83 V)	94 dB (1 W at rated impedance)	
Nominal Continuous Power Handling <sup>4</sup>	Passive	35 V (175 W @ 7 Ω)	
Nominal Maximum SPL <sup>5</sup>	Passive	Peak 122 dB	Continuous 116 dB
Rated Continuous Voltage <sup>6</sup>	Passive	29.2 V (29 dBV)	
Rated Maximum SPL <sup>7</sup> (Processed)	Passive	Peak 126 dB	Continuous 114 dB
Autoformer	70 V: 120 W, 60 W, 30 W, 15 W; 100 V: 120 W, 60 W, 30 W		
Recommended Amplifiers	Passive	175 W - 350 W into 8 Ω, (37 V - 53 V)	
Crossover Frequency	1.4 kHz		
Required Accessory	60 Hz, 12 dB/oct. electronic high pass filter		

### PHYSICAL

Input Connection	Lever-actuated wire clamping 4-position terminal block with pass-through
Controls	Wattage / low impedance selector switch
Mounting Provisions	ClickMount pan-tilt bracket or U-Bracket
Certifications	ETL listed to comply with UL 1480A and CSA STD C22.2# 62368-1
Environmental Rating	IP54 per IEC 60529, IEC 60068-2-5 (Solar Radiation), IEC 60068-2-11 (Salt Mist), IEC 60068-2-42 (SO <sub>2</sub> ), IEC 60068-2-60 (Chlorine)
Dimensions H x W x D	385 x 255 x 260 mm (15.16" x 10.04" x 10.24")
Weight	7.71 kg (17.0 lbs) - loudspeaker only
Finish	Refer to the Technical Drawings (pages 3 and 4)
Accessories (included)	ClickMount pan-tilt bracket or U-Bracket - dependent on models
Models (Order by color)	DX-S8 [-B/-W] - loudspeaker with small ClickMount pan-tilt bracket DX-S8-UB [-B/-W] - loudspeaker with U-Bracket and ClickPlug

### OPTIONS

Accessories	SPA-UBDX200 [-B/-W] U-Bracket with ClickPlug CMX-SM [-B/-W] ClickMount pan-tilt bracket
-------------	--

*Biamp strives to improve its products on a continual basis. Specifications are therefore subject to change without notice.*

DESONO

# DX-S8

TWO-WAY HIGH OUTPUT COAXIAL  
8-INCH SURFACE MOUNT LOUDSPEAKER

### AXIAL PROCESSED SENSITIVITY (dB SPL)<sup>8</sup>

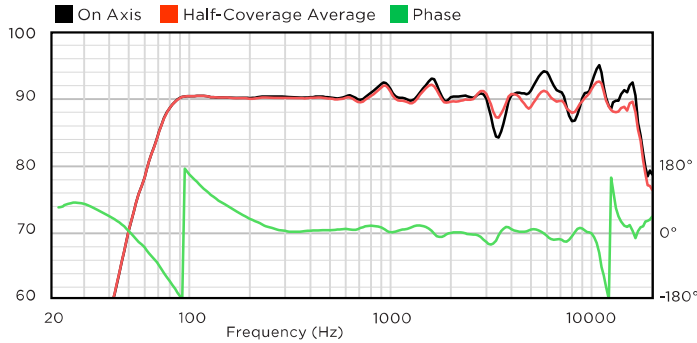

### HORIZONTAL OFF-AXIS RESPONSE (dB SPL)<sup>9</sup>

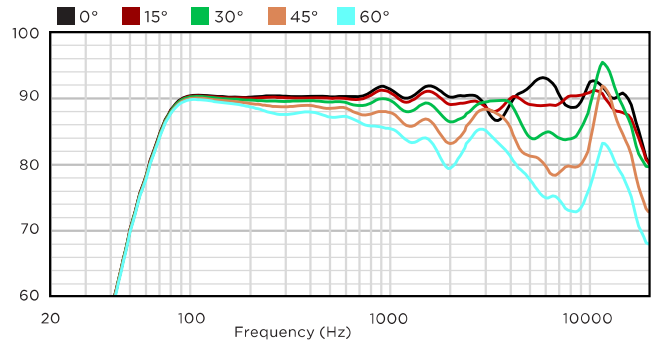

### AXIAL SENSITIVITY (dB SPL)<sup>8</sup>

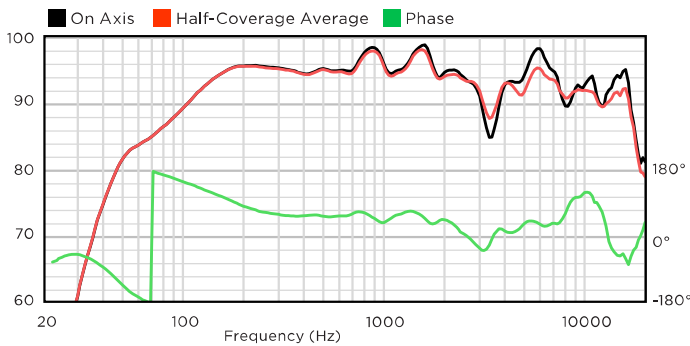

### VERTICAL OFF-AXIS UP RESPONSE (dB SPL)<sup>9</sup>

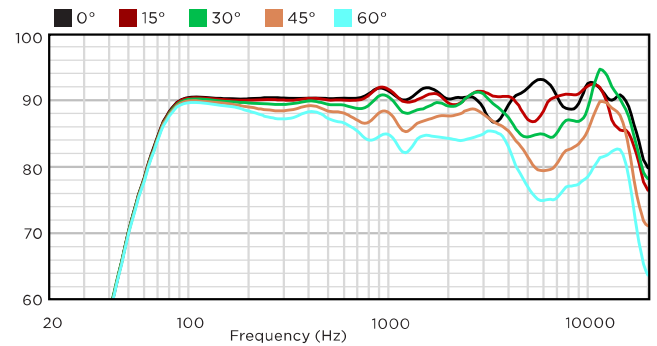

### IMPEDANCE (Ω)

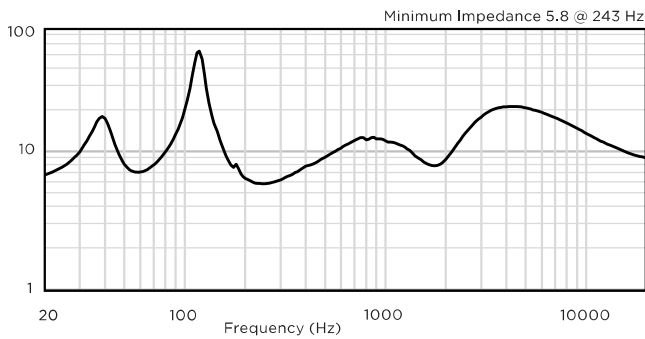

### VERTICAL OFF-AXIS DOWN RESPONSE (dB SPL)<sup>9</sup>

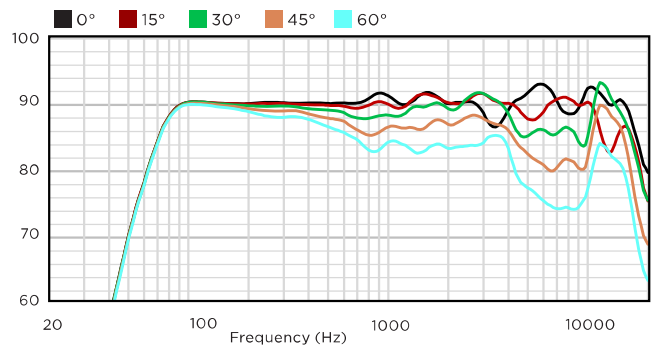

### DIRECTIVITY INDEX (dB)<sup>10</sup>

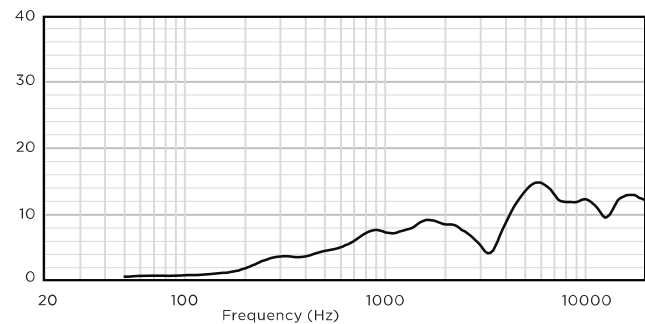

### BEAMWIDTH (degrees)<sup>11</sup>

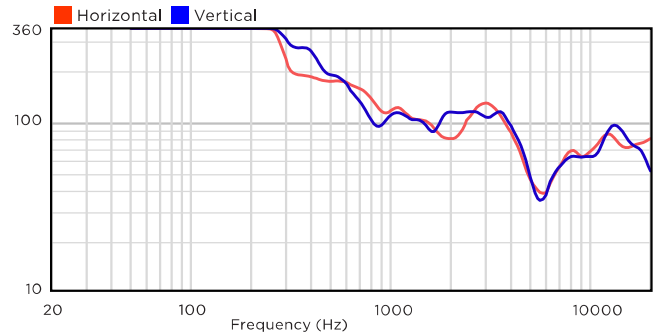

DESONO

# DX-S8

TWO-WAY HIGH OUTPUT COAXIAL  
8-INCH SURFACE MOUNT LOUDSPEAKER

### TECHNICAL DRAWING / DIMENSIONS / FINISH [DX-S8]

**H x W x D (loudspeaker only)**

385 x 255 x 260 mm  
(15.16" x 10.04" x 10.24")

**Unit Weight**

7.71 kg (17.0 lbs) loudspeaker only  
8.2 kg (18.0 lbs) loudspeaker + bracket

**Shipping Weight (shipped in pairs)**

19.1 kg (42.1 lbs)

**Grille**

Powder-coated perforated Marine Grade aluminum backed with woven fabric. Black (RAL 9017) or White (RAL 9016) finish.

**Enclosure / Bracket / Finish**

High-impact ABS plastic, painted UV resistant matte Black or White finish  
Bracket: Heavily reinforced glass-filled nylon with UV-resistant painted matte finish cover  
Color: Black (RAL 9017) or White (RAL 9016)

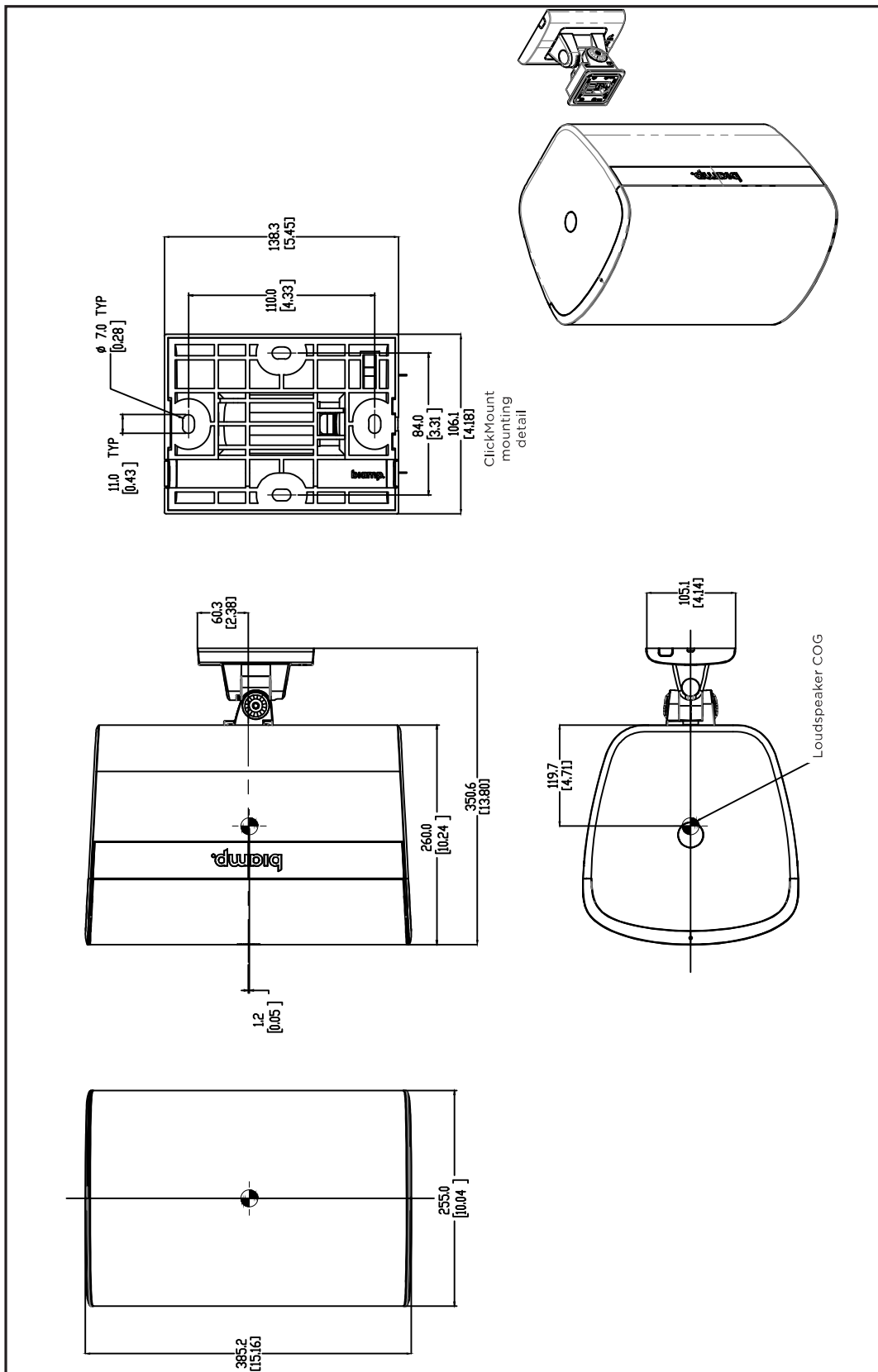

# DESONO DX-S8

TWO-WAY HIGH OUTPUT COAXIAL  
8-INCH SURFACE MOUNT LOUDSPEAKER

## TECHNICAL DRAWING / DIMENSIONS / FINISH [DX-S8-UB]

**H x W x D (loudspeaker only)**  
385 x 255 x 260 mm  
(15.16" x 10.04" x 10.24")

**Unit Weight**

7.71 kg (17.0 lbs) loudspeaker only  
8.21 kg (18.1 lbs) loudspeaker + bracket  
**Shipping Weight** (shipped in pairs)  
20.1 kg (44.3 lbs)

**Grille and U-Bracket**

Powder-coated Marine Grade aluminum. Grille is perforated and backed with woven fabric. Black (RAL 9017) or White (RAL 9016) finish

**Enclosure / Bracket / Finish**

High-impact ABS plastic, painted UV resistant matte Black or White finish  
Color: Black (RAL 9017) or White (RAL 9016)

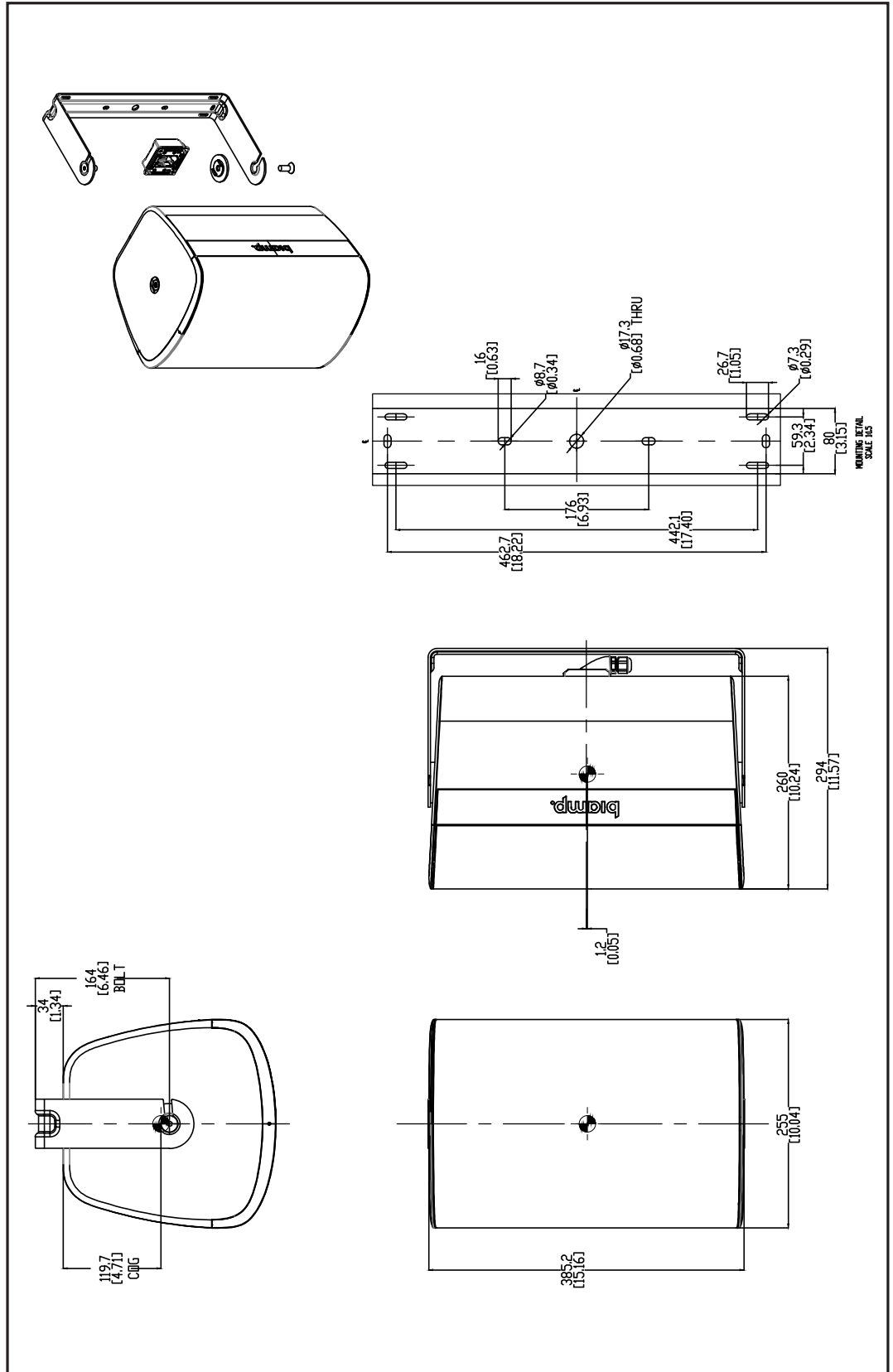

# DATA SHEET

## DESONO™

# DX-S8 TWO-WAY HIGH OUTPUT COAXIAL 8-INCH SURFACE MOUNT LOUDSPEAKER

### CONNECTION DIAGRAMS

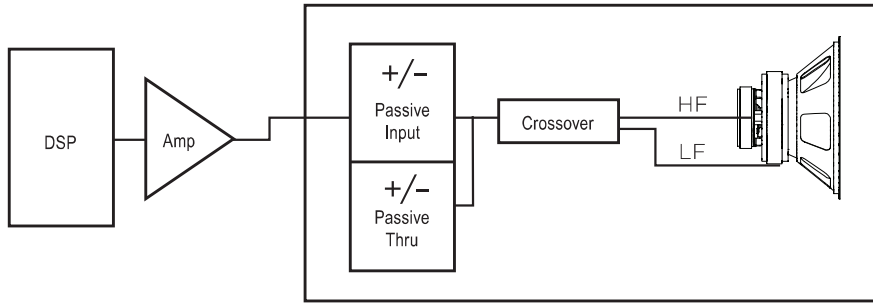

Single amp

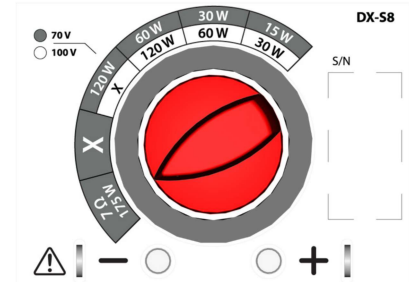

Tap Switch / Input Panel

### PAN-TILT AIMING ANGLES

Orientation	Pan 12° increments		Tilt 8° increments	
	Left	Right	Up	Down
Portrait (Vertical)	60° (5 clicks)	60° (5 clicks)	24° (3 clicks)	32° (4 clicks)
Landscape (Horizontal)	24° (2 clicks)	24° (2 clicks)	40° (5 clicks)	56° (7 clicks)



### U-BRACKET ROTATION

The loudspeaker will rotate 200° on the bracket - 100° in each direction.

### NOTES

- PERFORMANCE SPECIFICATIONS** All measurements are performed using a time-windowed impulse response to eliminate reflections, approximating an anechoic environment, at a distance of at least 6.0 m. All acoustic specifications are rounded to the nearest whole number. An external DSP using settings provided by Biamp is required to achieve the specified performance; further performance gains can be realized using the FIR loudspeaker optimization presets available in Biamp's Community Amplified Loudspeaker Controllers (ALC SERIES).
- OPERATING RANGE** The frequency range over which the on-axis equalized/processed response remains within 10 dB of the rated sensitivity, in accordance with IEC 60268-5.
- SENSITIVITY** The broadband SPL of the loudspeaker when pink noise is applied (band limited to the loudspeaker's Operating Range) at an input voltage of 2.83 V, in accordance with IEC 60268-5. Also listed for a voltage that would produce 1 watt into the nominal impedance. Measured in whole space with no external processing applied, except where indicated.
- NOMINAL CONTINUOUS POWER HANDLING** The maximum continuous nominal input voltage at the rated impedance that the system can withstand, without damage, for a period of 2 hours using an IEC 60268-1 defined spectrum with recommended signal processing and protection filters.
- NOMINAL MAXIMUM SPL** The SPL produced when an IEC 60268-1 signal is applied, at the nominal input voltage, to the equalized/processed loudspeaker system. Referenced to a distance of 1 meter. The peak SPL represents the 2:1 (6 dB) crest factor of the IEC 60268-1 test signal.
- RATED CONTINUOUS VOLTAGE** The maximum continuous rated input voltage for the system that results in no more than a 3 dB change in the system's response during operation.
- RATED MAXIMUM SPL** The SPL produced when a typical program material signal is applied to the equalized/processed loudspeaker system, at a level which drives at least one subsection to its rated continuous voltage limit. Referenced to a distance of 1 meter. The peak SPL represents the 4:1 (12 dB) crest factor of the program signal.
- AXIAL (PROCESSED) SENSITIVITY** The variation in acoustic output level with frequency for a swept-sine measurement signal. The Processed measurement uses the recommended signal processing for the loudspeaker system. The other sensitivity measurements use no additional external processing. All data are referenced to 1 meter. The on-axis magnitude and phase responses, as well as the average magnitude response, calculated over one-half of the nominal coverage angles, are shown. The responses have 1/6 octave smoothing applied.
- HORIZONTAL / VERTICAL OFF-AXIS RESPONSES** The loudspeaker's magnitude response at various off-axis angles using the recommended signal processing in the operating mode which utilizes the largest number of individually amplified pass bands. The responses have 1/3 octave smoothing applied.
- DIRECTIVITY INDEX** The ratio of the on-axis SPL to the mean SPL at the same distance for all points within the measurement sphere for each given frequency; expressed in dB. The response has 1/3 octave smoothing applied.
- BEAMWIDTH** The included angle between the -6 dB points in the polar response of the loudspeaker when driven in the operating mode which utilizes the largest number of individually amplified pass bands. The responses have 1/3 octave smoothing applied.

Data presented on this data sheet represents a selection of the basic performance specifications for the model. These specifications are intended to allow the user to perform a fair, straightforward evaluation and comparison with other loudspeaker spec sheets. For a detailed analysis of this loudspeaker's performance, please download the GLL file and/or the CLF file from our website: [www.biamp.com](http://www.biamp.com)