

**COMMERCIAL LOUDSPEAKERS**  
**CCA-80 CONSTANT COVERAGE AISLE LOUDSPEAKER**

**Installation Guide**

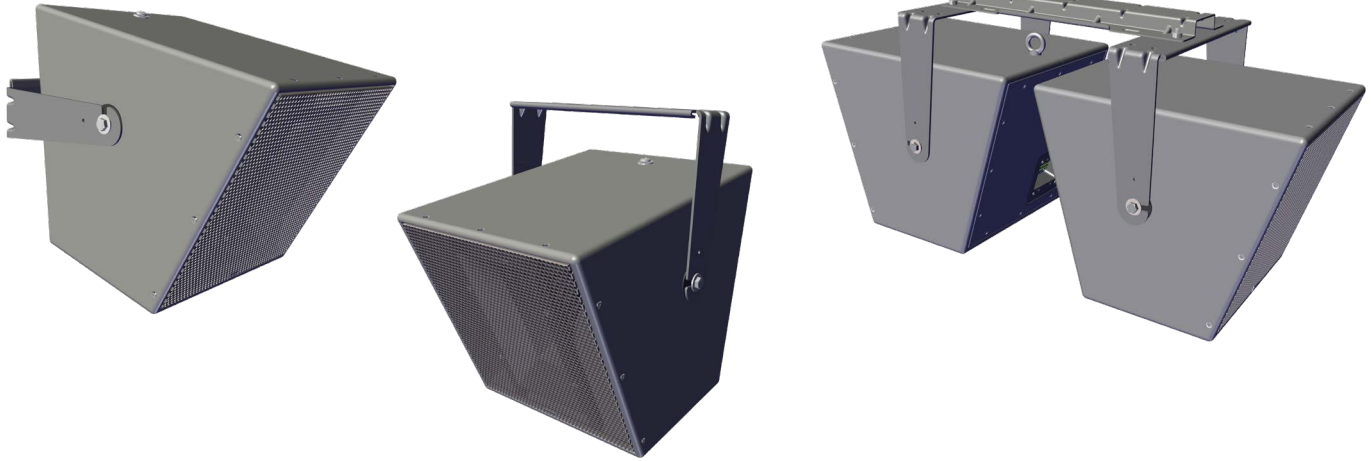

**PRODUCT DESCRIPTION**

- Purpose-built for long aisles and concourses in warehouses, sports complexes, shopping malls, hotels, themed entertainment venues, and more
- Efficient design with 70V/100V transformers for cost-effective sound reinforcement
- Dual speaker option provides additional mounting flexibility and reduced total system costs

**INSTALLER SUPPLIED TOOLS / HARDWARE**

- Safety-rated M10 Eyebolt or fastener, and safety cable
- Phillips screwdriver
- Small flat screwdriver
- 17mm Socket or Wrench
- Inclinometer

**ACCESSORIES (OPTIONAL)**

- M10EYBLTKIT - (4) M10 Eyebolts
- SPA-HBC 100 - Beam Clamp Kit

**CONTENTS (CCA-80)**

- CCA-80 Loudspeaker
- Mounting Bracket
- Hardware
  - M10 Hex Bolts (2)
  - M10 Flat Washers (3)
  - M10 Phillips Bolt (1)
  - M4 Phillips screws (4)
- Documentation: Bracket drilling template with QR code to access online manual; Loudspeaker Safety Guide



CCA-80 Loudspeaker

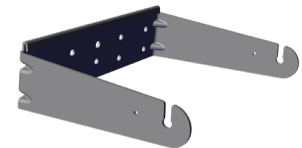

mounting bracket

**CONTENTS (CCA-80D)**

- CCA-80 Loudspeaker (x2) (contents noted above)
- Dual Mounting Bracket
- Hardware
  - M10 Hex Bolts (4)
  - M10 Flat Washers (4)
- Documentation: Quick Instruction sheet with QR code to access full online manual

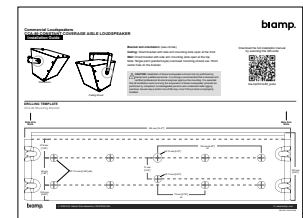

Bracket Drilling Template

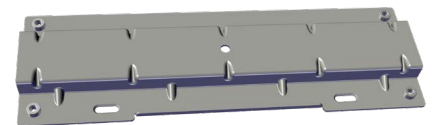

CCA-80D Dual Mounting Bracket

## PRODUCT REPRESENTATION

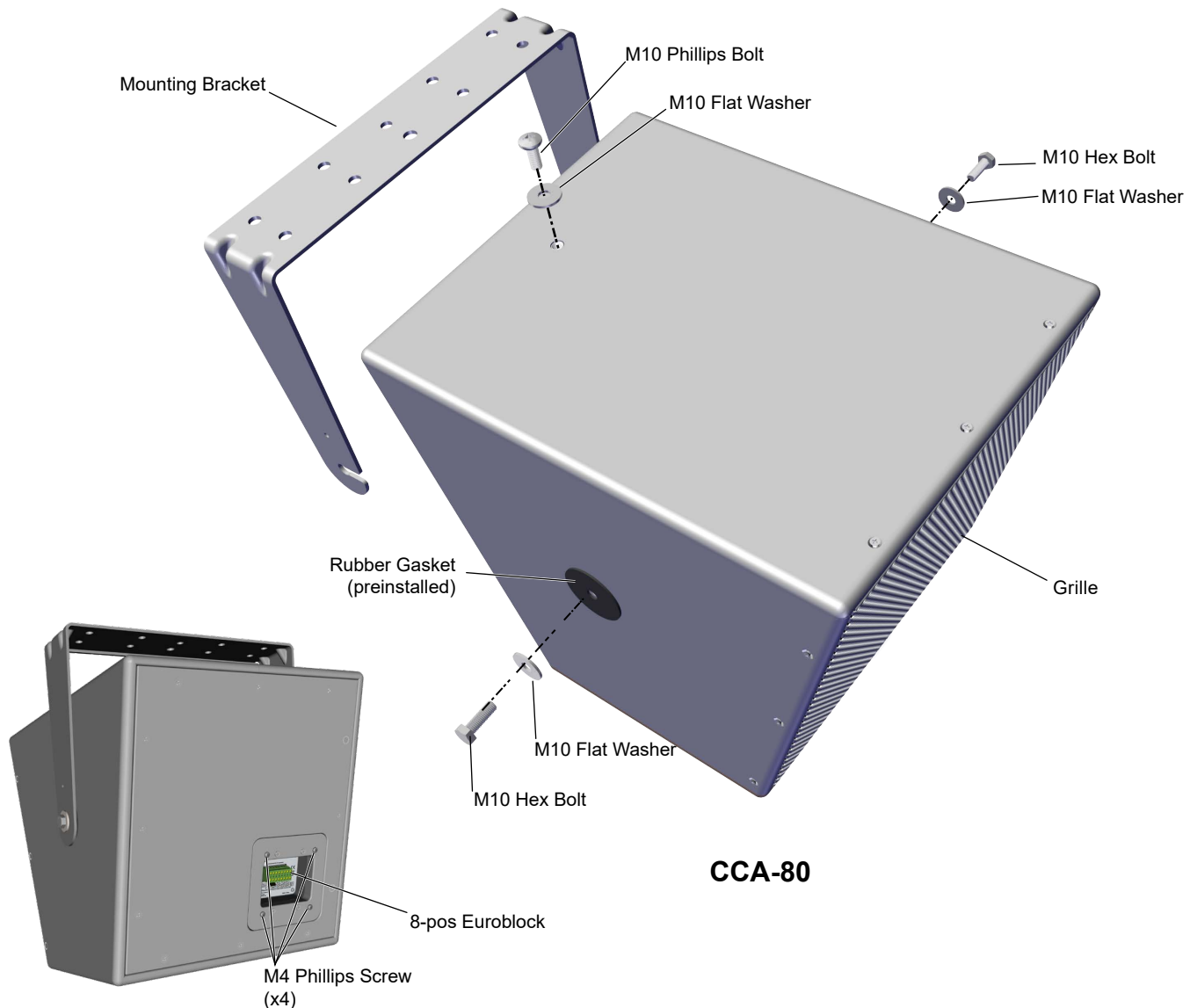

## RIGGING AND ELECTRICAL SAFETY



**IMPORTANT:** The loudspeaker described in this manual are designed and intended to be mounted to differing building surfaces using a variety of rigging hardware, means and methods. Installation of loudspeakers should only be performed by trained and qualified personnel. All electrical connections must conform to applicable city, county, state, and national (NEC) electrical codes.



**DANGER:** The output power capabilities of audio amplifiers present a danger to installers especially in 70-volt and 100-volt distributed systems. To minimize the risk of electric shock from loudspeaker connecting cables, confirm that the power amplifiers are turned "off" before connecting loudspeaker cable(s) to the loudspeaker or amplifier. Always follow local electrical codes and proper electrical safety procedures.



**IMPORTANT:** Refer to the sections on installation and connections later in this manual for additional information on rigging and electrical safety.



**IMPORTANT:** Please review the safety guide accompanying this product and these installation instructions prior to installing this loudspeaker.



**CAUTION:** Installation of Biamp loudspeakers should only be performed by trained and qualified personnel. It is strongly recommended that a licensed and certified professional structural engineer approve the mounting. Severe injury and/or loss of life may occur if this product is improperly installed.



**DANGER:** It is advised that a safety cable be secured to a suitable load-bearing point separate from the primary loudspeaker mounting point, with as little slack as possible so as not to develop undue kinetic force if the primary mount were to fail.

# PRODUCT INSTALLATION

## Basic Installation Steps:

The loudspeaker is intended to be installed indoors and connected directly to an amplifier with digital signal processing (DSP). It must have factory processing (high pass filter & limiter) applied to prevent damage. The loudspeaker is designed to be oriented with the angled grille aiming out and down. It is not designed to be rotated.

- Run wires to locations as defined by system design
- Mount brackets (may also be done when installing the loudspeakers)
- Attach the loudspeakers to the brackets, set the angles and make the wiring connections
- Power the amps and commission/test the system

## Mount Bracket to Structure

Follow the system design recommendations for placement and spacing. Run cabling to each location.

1. Use bracket template to mark holes.

**Important:** Bracket attachment hardware must be supplied by the installer and rated for the load and structure material.

2. Mount the bracket with the side arm slots oriented correctly. (See circles noting slot direction).

**Overhead Mounting:** Single point (pendant-type) mounting should utilize the 13mm center hole on the bracket (blue highlight). Beam clamps should attach to any two holes on either side and in line with the large center hole (yellow highlight), if feasible. Those holes are fairly aligned with the loudspeaker's center of gravity.

1

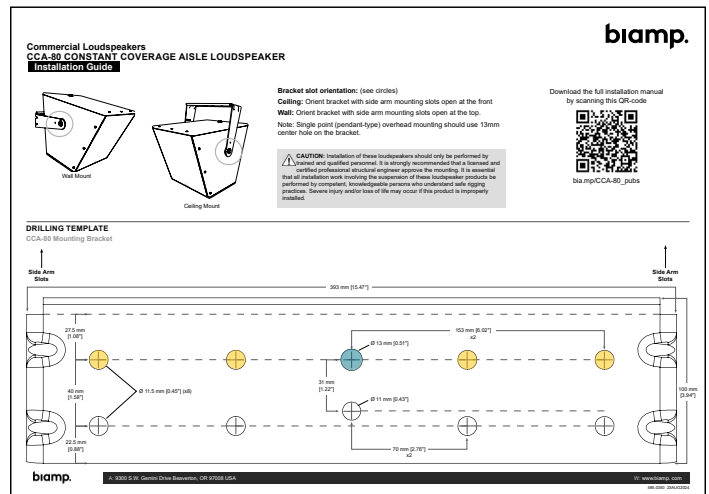

2

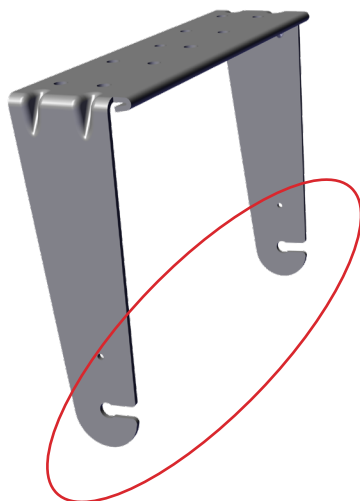

**Ceiling Orientation**  
(bracket mounted above)

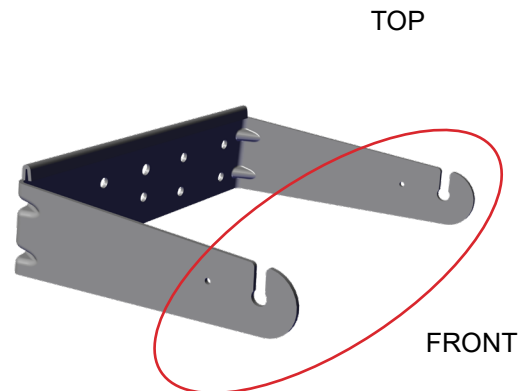

**Wall Orientation**  
(bracket mounted behind)

## Install the Loudspeaker

1. Install the side hardware (x2). The rubber gaskets are preattached to the side of the cabinet. Install the bolt and flat washer as shown.
2. Leave approximately 6-7 mm (.25") of thread exposed on the bolts.
3. Safety Cable: Remove the Phillips head bolt and flat washer from the top mounting point. Install an M10 eyebolt or similar load-rated fastener. Refer to the grey box on the next page for details. *The eyebolt is shown as an example.*

**Note:** Community Accessory M10EYBLTKIT kit contains 4 eyebolts and is suitable for this use.

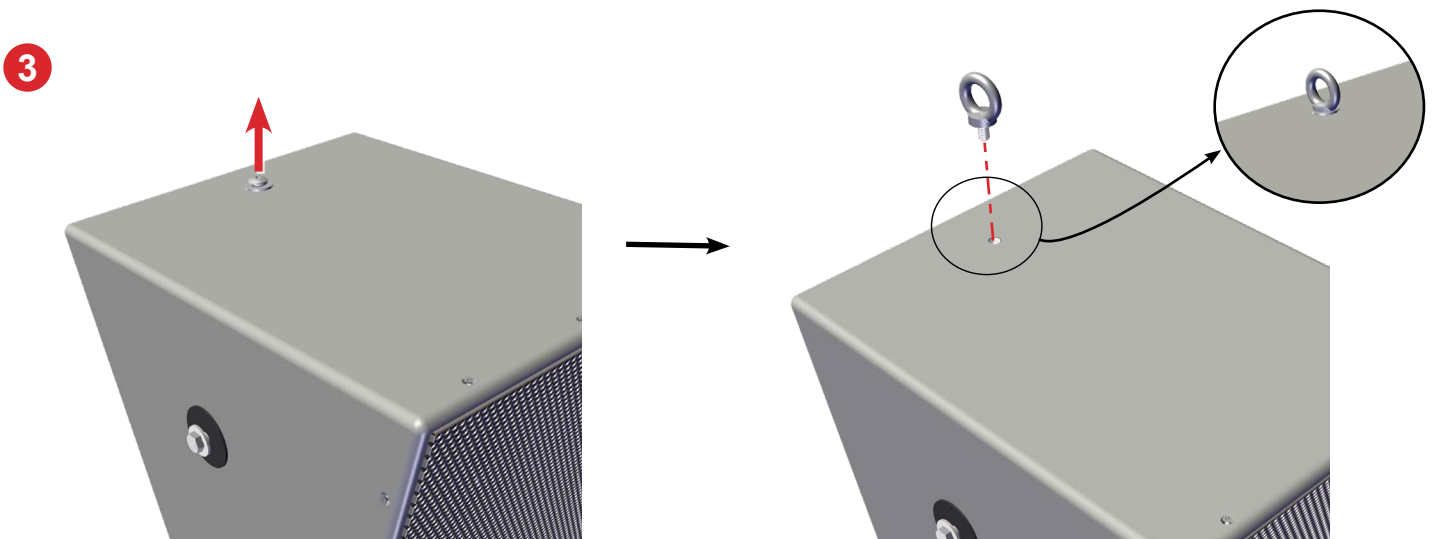
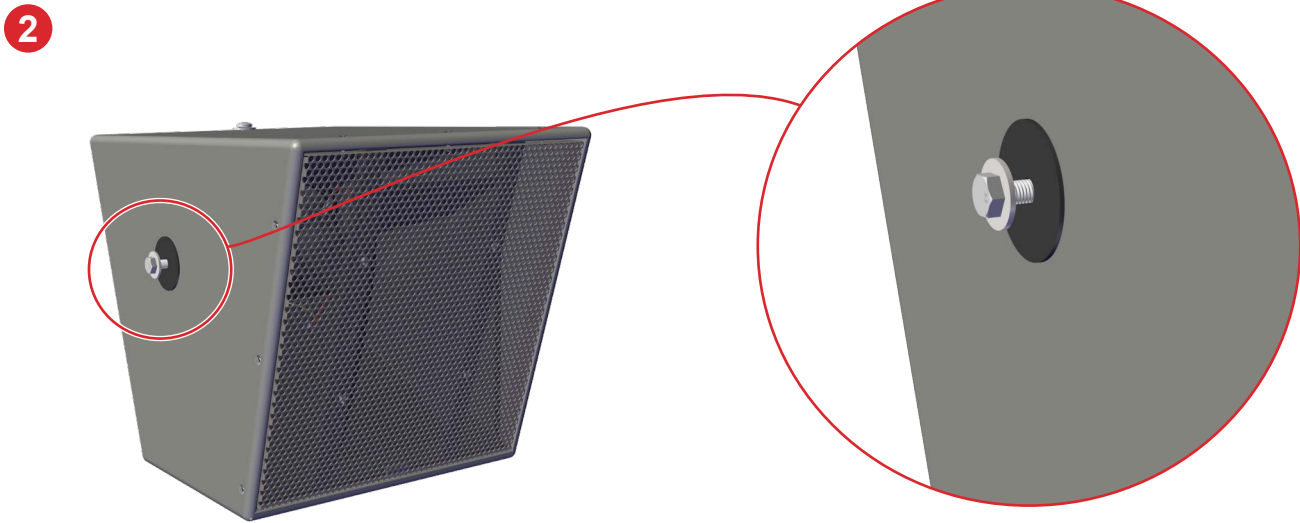
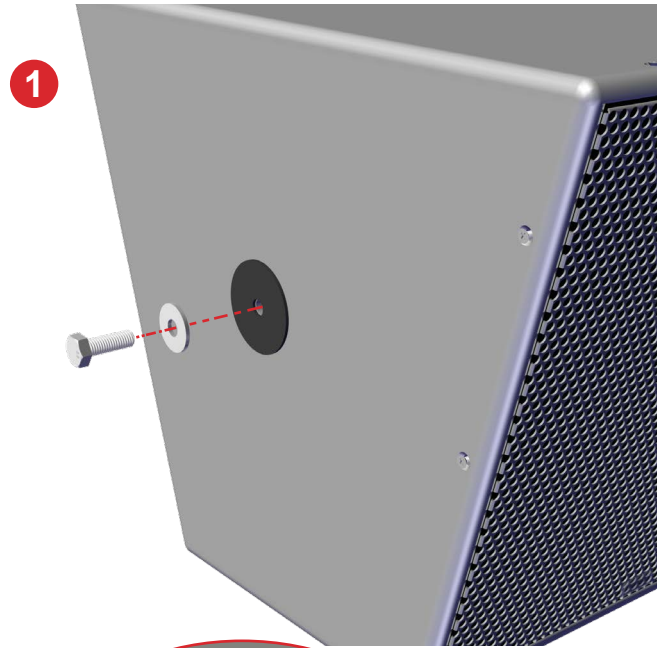

## Install the loudspeaker (continued)

4. Mount the loudspeaker on the bracket as shown.
5. Snug tighten the bolts to set the aiming angle, and fully tighten once that angle is set.  
(Maximum torque 11.86 Nm [8.7 ft-lb])
6. Ensure all (3) mounting points are filled with hardware to maintain performance and preserve the product warranty.
7. Power and test the system. Refer to safety information at right.

*The safety cable and hardware are not included.* Consult a structural engineer for the appropriate cable for the load and application. The safety cable must be secured to a suitable load-bearing point separate from the loudspeaker mounting point, with as little slack as possible, so as not to develop undue kinetic force if the primary mounting were to fail.

4

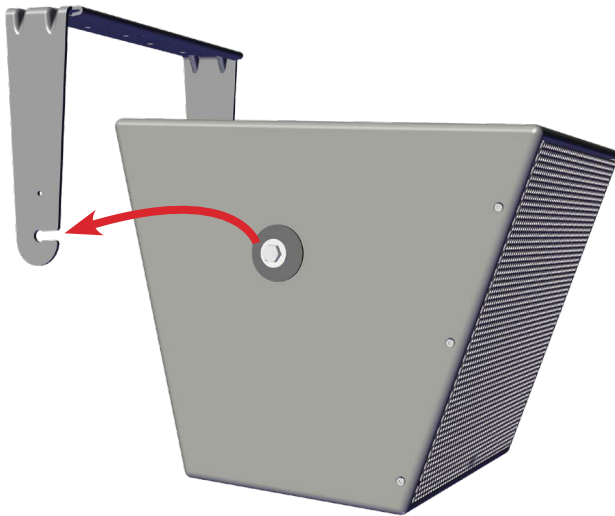

5

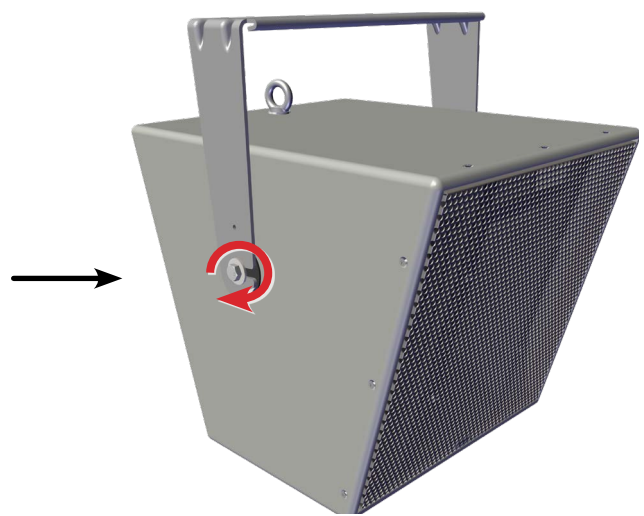

## Aiming Angles

Use an inclinometer to set the cabinet downtilt as specified in the report(s) from the system designer. Downtilt angles are in increments of 1°. Maximum tilt with an overhead hang is approximately 23°-25° depending if an eyebolt is used for the safety cable.

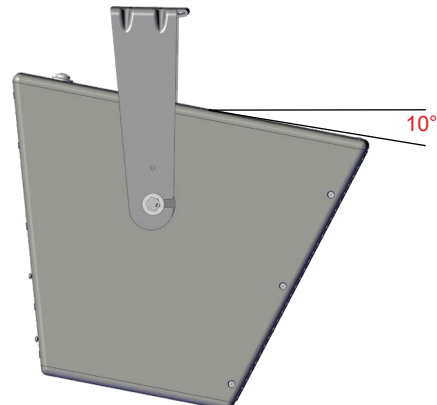
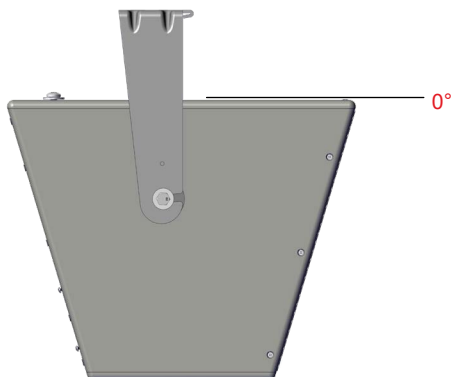

## Final Installation Steps

- Once the system has been tested and the coverage angle verified to be correct, the bracket may optionally be locked into place by screwing a M5 x 20 (or #10 x3/4") screw through the smaller hole and into the cabinet. Screws are installer-supplied.

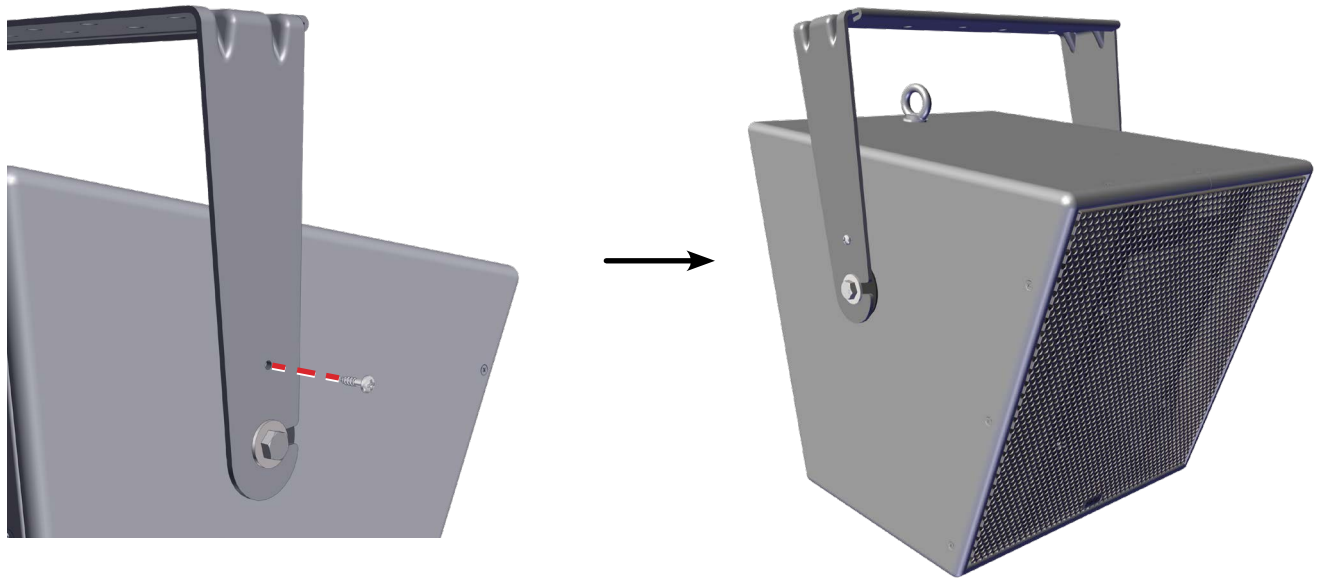

**Note:** If the aiming angle is 0-5° the friction of the bracket against the rubber gasket will be enough to maintain the angle. For angles more than 5°, Biamp recommends installing a screw to guarantee long term stability of the cabinet angle.

## Dual Bracket (CCA-80D) Installation

The Dual Bracket kit allows two CCA-80s to be mounted back to back from a central mounting point and aimed in opposite directions.

### Basic Installation Steps:

- Run wires to locations as defined by system design
- Mount Individual brackets to the dual bracket (may also be done when installing the loudspeakers)
- Mount the dual bracket to the structure
- Attach the loudspeakers to the u-brackets, set the angles and make the wiring connections
- Power the amps; commission and test the system



Distance between cabinet centers = 500 mm (19.69")

Next page >>

## Dual Bracket (CCA-80D) Installation (continued)

1. Attach the CCA-80 U-Brackets (2) to the underside of the dual bracket. Ensure the U-Bracket slots face out.
2. If using a jumper wire to go from one cabinet to the other, thread it through the oblong holes as shown. It can be secured with cable clips on the rear panel.
3. Attach the dual bracket to the structure. A center hole is provided for this purpose. The Installer must provide hardware sufficient for the load and structure. The combined weight of CCA-80s and the dual bracket is 70.5 lbs [32 kg].
4. Follow the steps 4-7 ([page 5](#)) to hang and secure the CCA-80 cabinets on the U-Brackets.

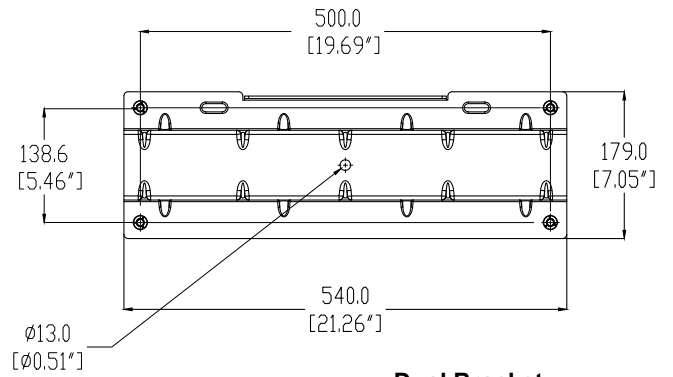

Dual Bracket

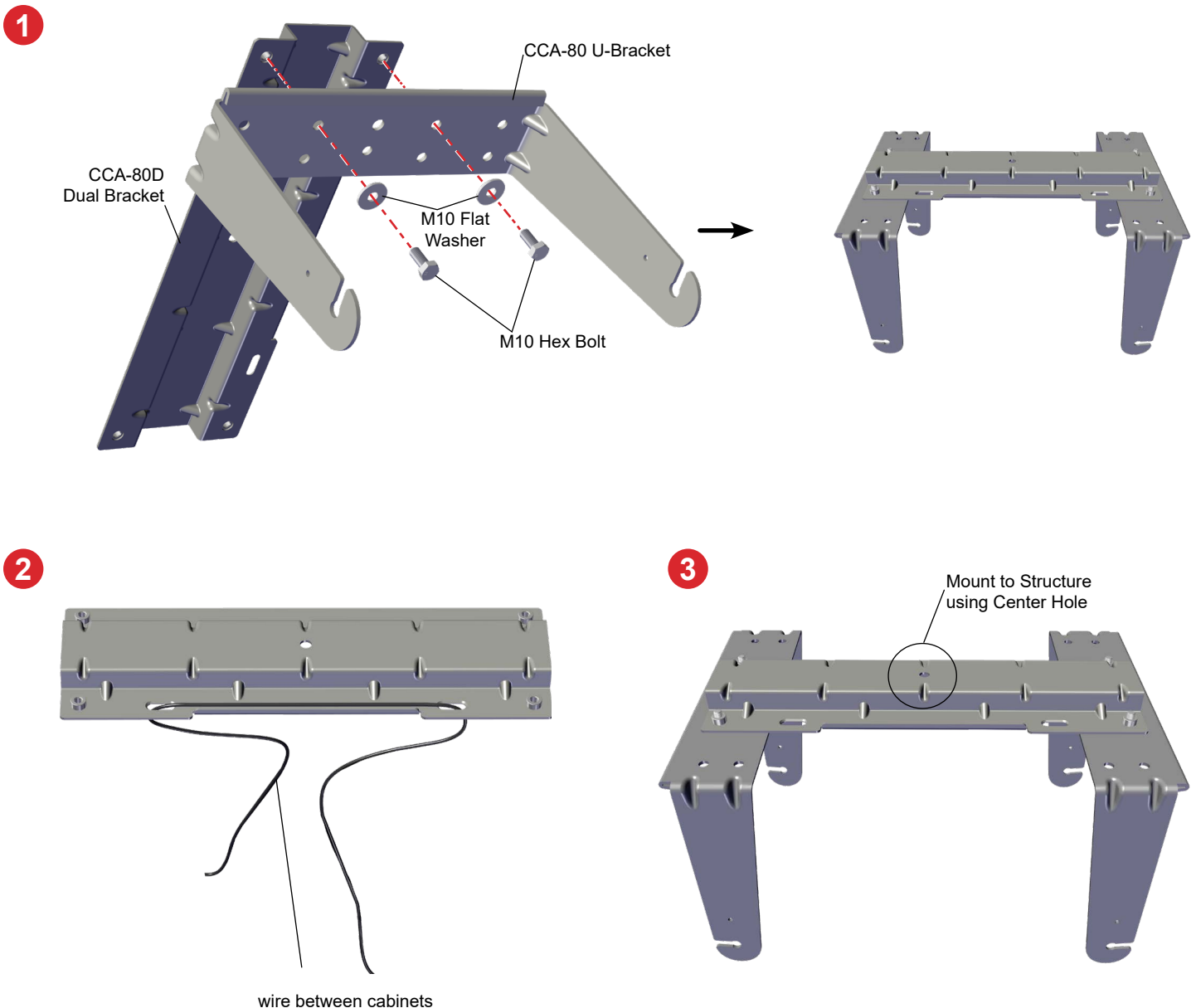

## Wire the Loudspeaker

The loudspeaker is intended to be connected directly to an amplifier with digital signal processing (DSP). It must have factory processing (high pass filter & limiter) applied to prevent damage.

The euroblock will accept 12 ga and smaller wires. The input panel area may be covered with a installer-supplied standard dual gang plate - 2 hole patterns (US & EU) and 4 connection screws are included. If a cover or conduit is being used, prepare it and thread the wire through, leaving enough to attach to the euroblock.

### 1. Wire the euroblock.

See **1a** for 8 ohm low impedance operation - jumper must be moved to unused terminals or removed from the euroblock connector.

See **1b** for 70V/100V operation. Use the appropriate tap for your application. **Keep the jumper in place on the 8  $\Omega$  and Jumper terminals.**

See **1c** for an example of pass-thru wiring to another cabinet. The conductors should mirror each other on the euroblock.



Standard Wiring



Wire Ferrule (optional)

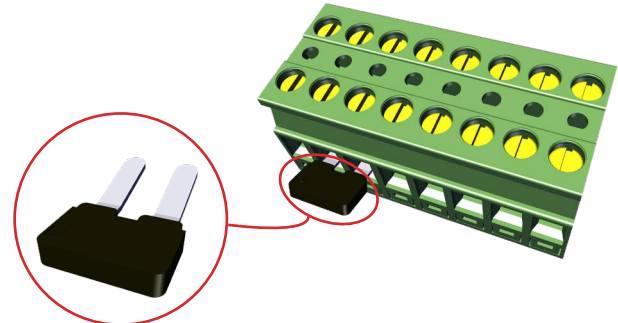

8-position euroblock dual-sided connector  
(Jumper is pre-installed)

1a

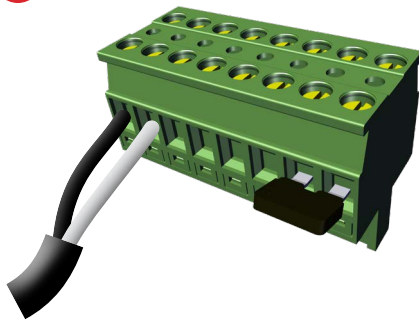

**Low Impedance operation**  
(move preinstalled jumper to unused terminals)

1b



**70 V / 100 V operation**  
(keep jumper on 8  $\Omega$  and Jumper positions)

1c



**Pass-thru to another cabinet**

## Wire the Loudspeakers (continued)

2. Be consistent in wiring the euroblock terminals - the incoming wire should be on the lower side and the outgoing wire on the upper side.
3. Plug each Euroblock into their respective cabinets.

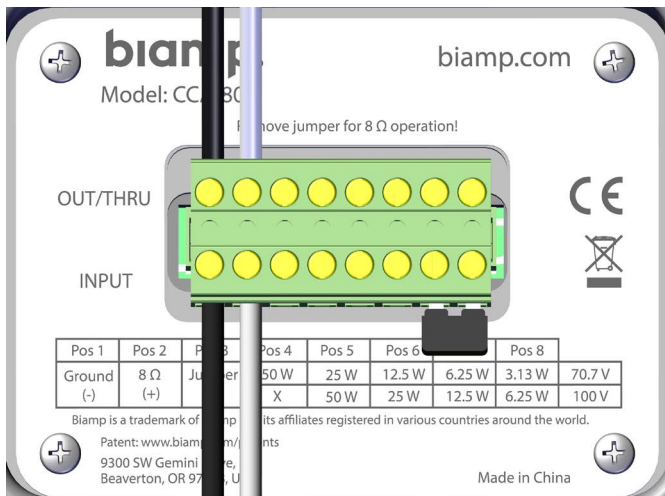
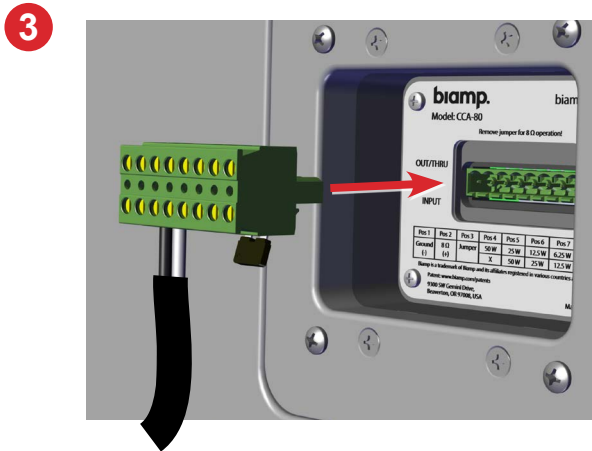
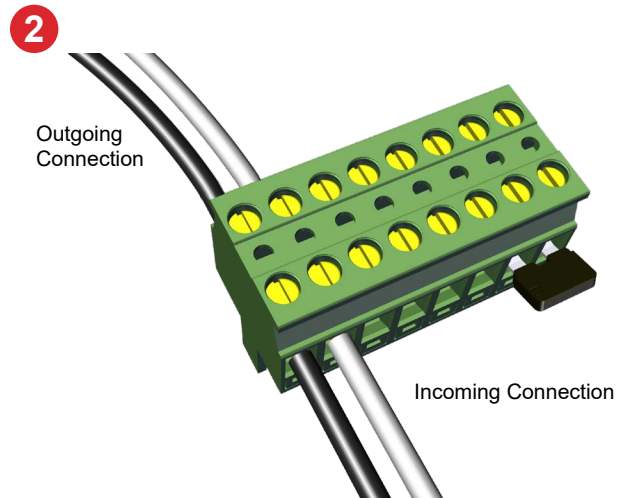

**Cabinet with pass-thru connection**  
(8 Ω operation shown)

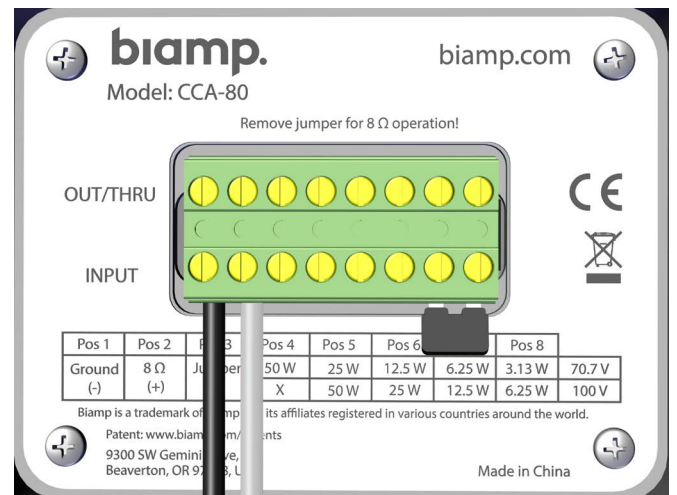

**Cabinet - independently wired**  
(or last cabinet in series)

## Cover Installation

There are preinstalled screws in the cabinet that can be used to attach a cover over the input area .

**Note:** Installer must supply the cover, cable clamp and conduit.

### Cover Installation:

Loosen or remove the screws to install the cover (the wire should have been threaded though before wiring the euroblock (typical slotted cover shown). Remove screws if the cover has holes rather than slots.

Once the cover is in place, tighten screws to secure it.

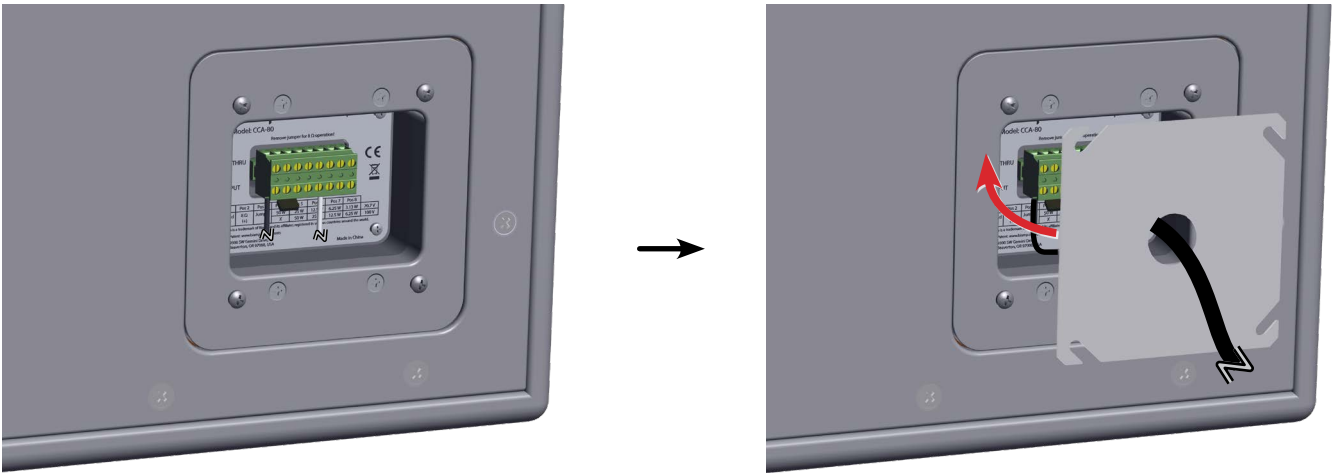

*Cable clamp or conduit fitting not shown*

### Alternate hole location:

Remove the preinstalled screws and flat head M4 screws. The button head screws will typically be used in the centermost holes (shown) to install a cover. Install cover and tighten screws.



## CONTACT US

Email: [support@biamp.com](mailto:support@biamp.com)

Warranty: [biamp.com/legal/warranty-information](http://biamp.com/legal/warranty-information)

Web: [support.biamp.com](http://support.biamp.com)

Safety & Compliance: [biamp.com/compliance](http://biamp.com/compliance)

**biamp.**

A: 9300 S.W. Gemini Drive Beaverton, OR 97008 USA

W: [www.biamp.com](http://www.biamp.com)

19NOV2024