

# Whirlwind FP-1 & FP-2 floor pockets

## INSTALLATION DIAGRAMS

### FP-1 and FP-2 Installation Instructions

whirlwind **FP-1** and **FP-2** Floor Pockets can be mounted directly into a cutout in a wooden floor or can be installed on whirlwind **FP-1BB** and **FP-2BB** electrical style back boxes.

The **FP-1BB** and **FP-2BB** back boxes are N.E.M.A. Type 1 electrical enclosures 4" deep, gray enamel with knockouts. 6" deep boxes, which provide more wiring space, are also available as **FP-1BB6** and **FP-2BB6**. whirlwind recommends using our back boxes to ensure proper fit and hole alignment. Other brands of boxes may have incompatible flange widths and mounting hole patterns. Verify compatibility before installation.

### INSTALLATION WITHOUT BACK BOX

Use the supplied, full size template to lay out the hole pattern and cutout. The 5/32" diameter holes allow for use of the supplied 10-32 x 1.5" type F screws to mount the box frame. Other #10 flat head wood or tapping screws can also be used. The 3/16" diameter holes in the **FP-1** template are for clearance of the cover mounting screws.

### INSTALLATION WITH BACK BOX

**FP-1BB** and **FP-2 BB** Back Boxes should be installed so that the top of the Back Box is 1/2 to 1" below the height of the finished floor. This allows for adjustment at final installation and provides clearance for wiring in the bottom of the box. Conduits attached to the box should be mounted as close as possible to the bottom of the box.

### INSTALLATION IN CONCRETE

For installation in concrete attach a piece of 1/2 inch plywood of identical size to the top of the back box and tape all open gaps. This will ensure that the back box is installed at a correct depth so that the concrete is flush and will not leak in. Adjust depth for additional flooring on top of the concrete. Before installation check building codes for additional operations and or preparations.

### REMOVABLE CONNECTOR PANELS

**FP-1** and **FP-2** floor pockets have removable end and bottom panels for connector mounting. Two types of end plate are supplied; blank and pre punched for four whirlwind **WC3F** and **WC3M** style connectors. The bottom panel can accept small multi pin connectors and other types when used with a deep back box.

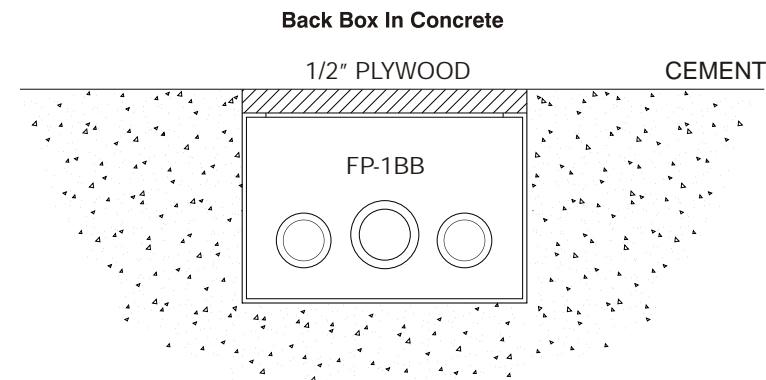
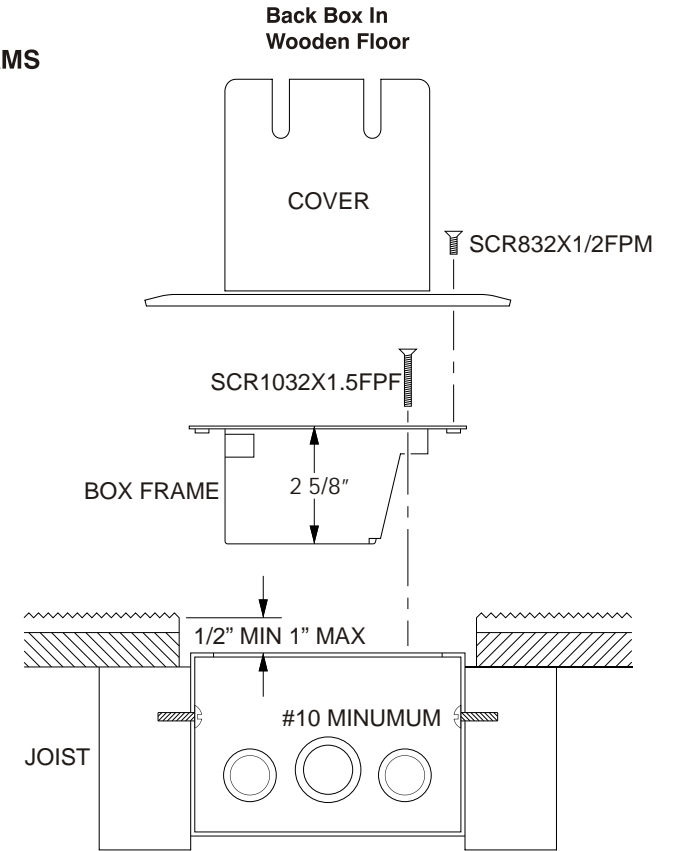
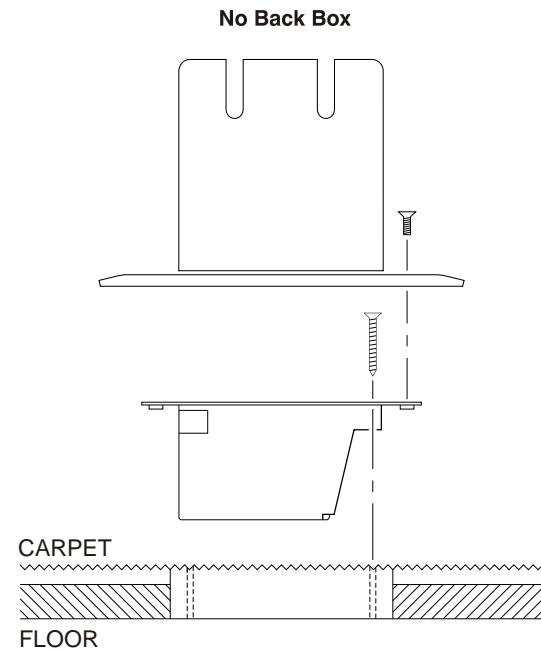

# Parts Explosions

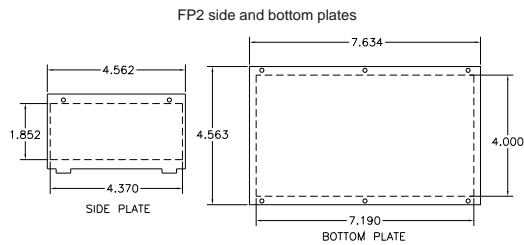
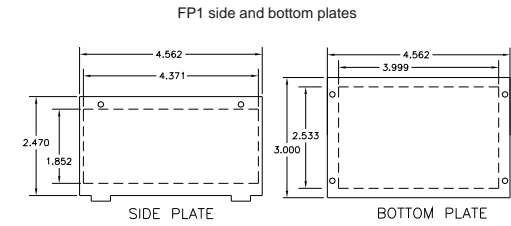
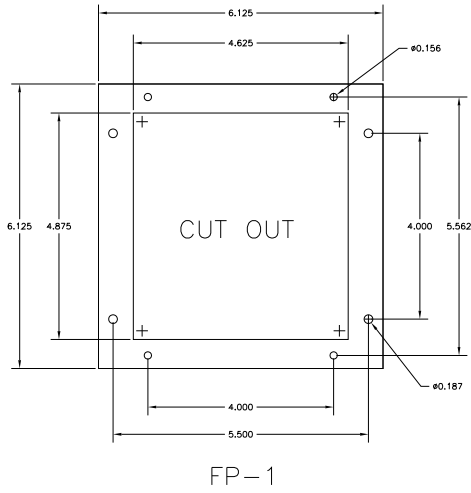

FP-1

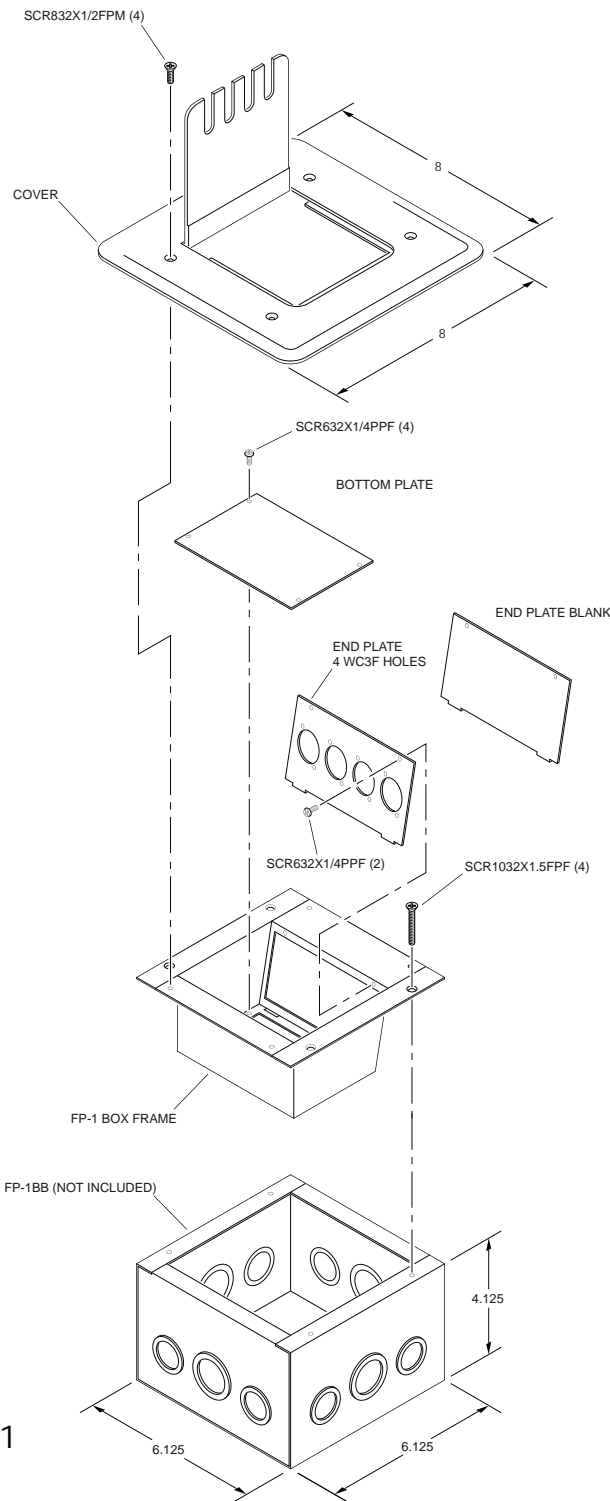

NOTE : included SCREWS (SCR440X1/2FPM) and NUTS (NUT4-40KEPS) for mounting WC3F connectors to END PLATES not shown.

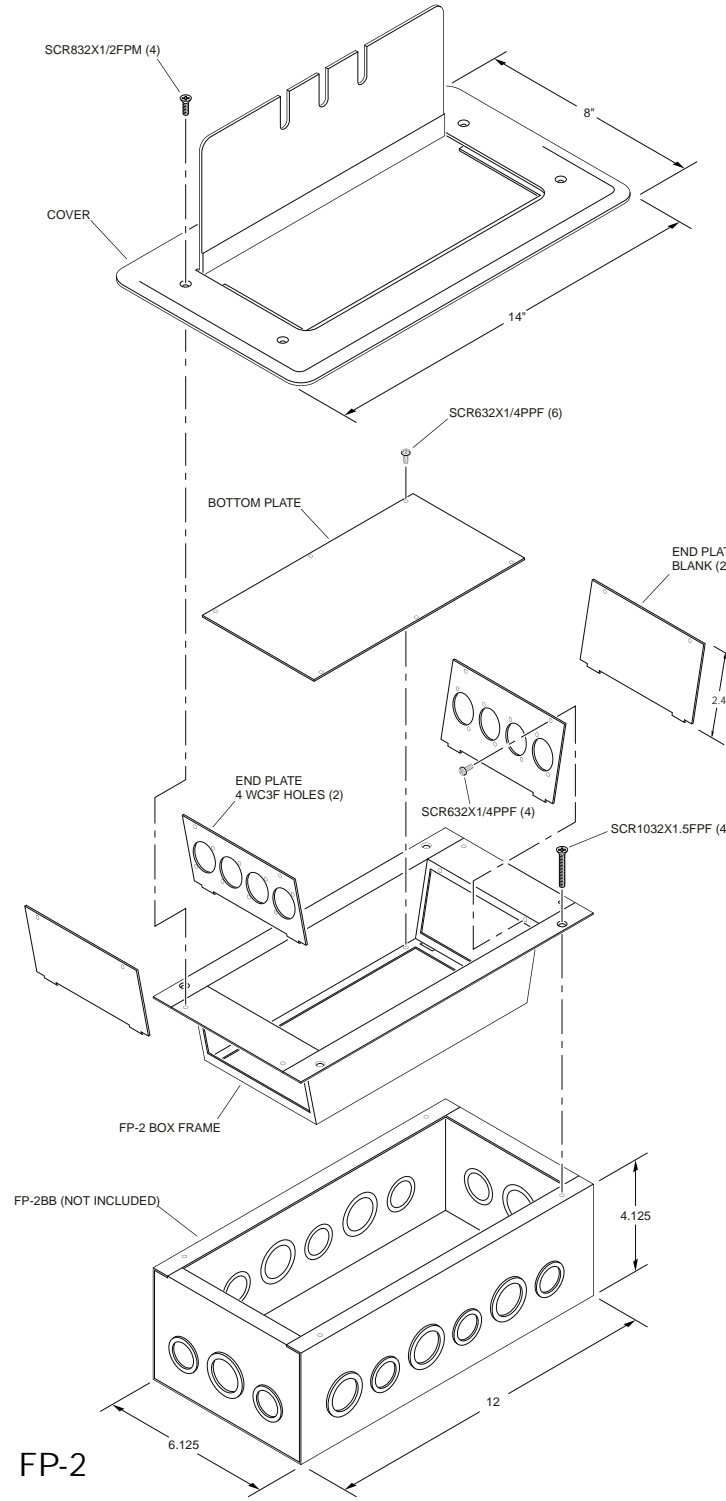
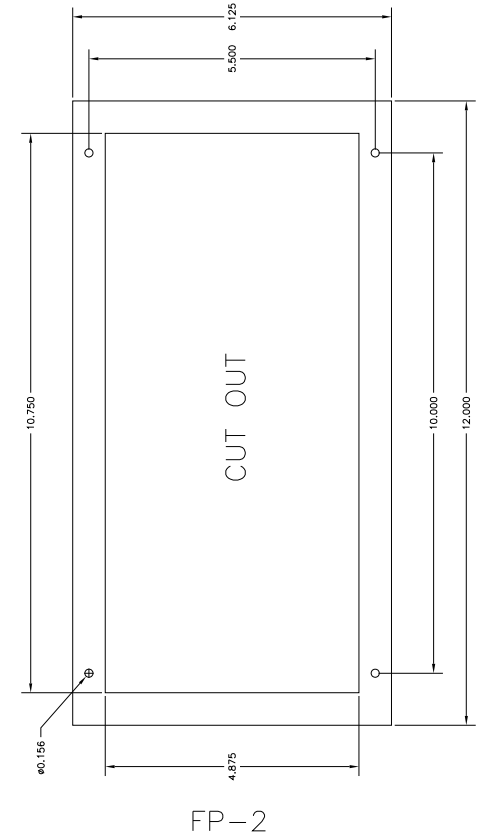

FP-2

99 Ling Road. Rochester, NY 14612  
Phone 800 733-9473  
Email: sales@whirlwindusa.com  
http://www.whirlwindusa.com