



SERVICE MANUAL

Series 1 and 2

M810 / M1610

MODEL TYPE: YS1032 (M1610)
MODEL TYPE: YS1033 (M810)

WEB ACCESS: <http://www.yorkville.com>

WORLD HEADQUARTERS CANADA

Yorkville Sound
550 Granite Court
Pickering, Ontario
L1W-3Y8 CANADA

Voice: (905) 837-8481
Fax: (905) 837-8746

U.S.A.

Yorkville Sound Inc.
4625 Witmer Industrial Estate
Niagara Falls, New York
14305 USA

Voice: (716) 297-2920
Fax: (716) 297-3689



Quality and Innovation Since 1963
Printed in Canada

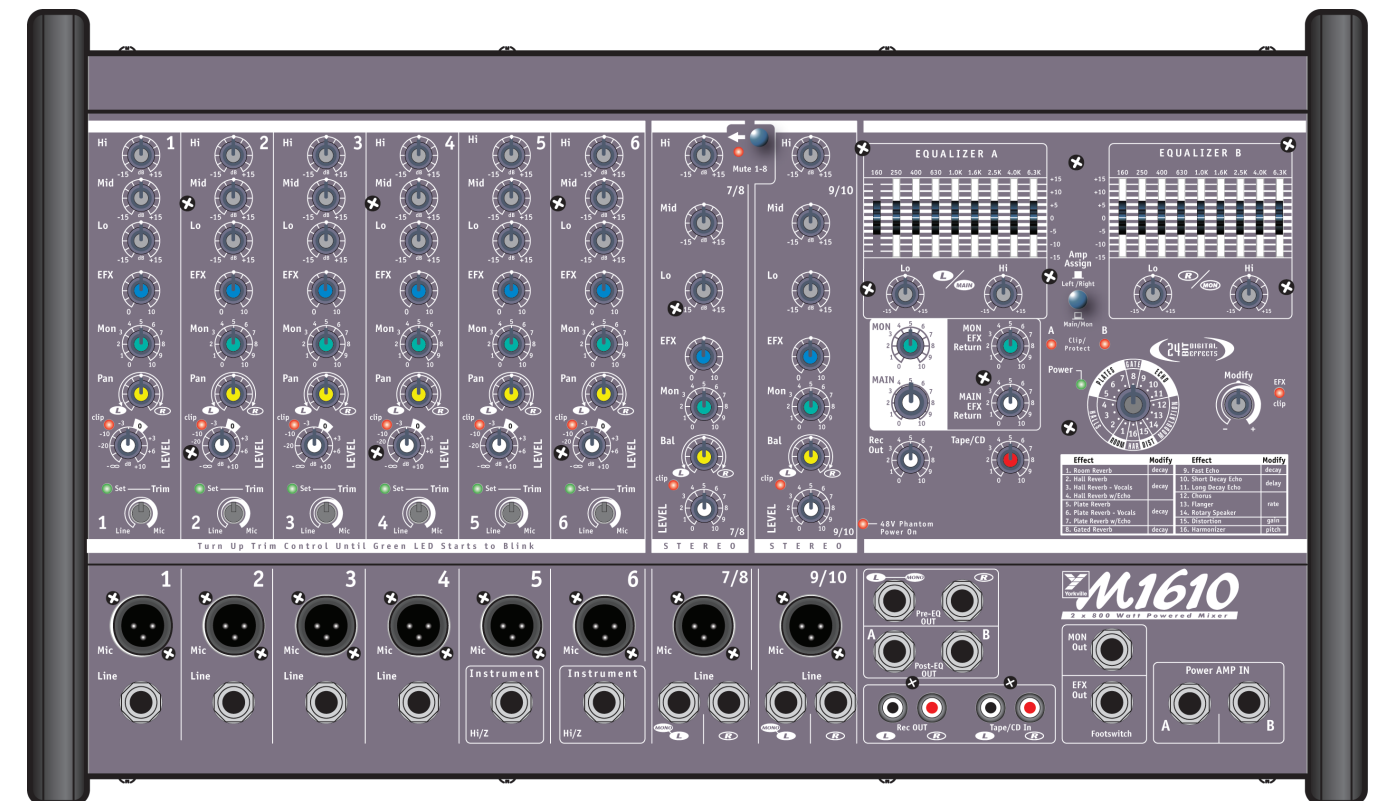

IMPORTANT SAFETY INSTRUCTIONS



This lightning flash with arrowhead symbol, within an equilateral triangle, is intended to alert the user to the presence of uninsulated "dangerous voltage" within the product's enclosure that may be of sufficient magnitude to constitute a risk of electric shock to persons.

Ce symbole d'éclair avec tête de flèche dans un triangle équilatéral est prévu pour alerter l'utilisateur de la présence d'un « voltage dangereux » non-isolé à proximité de l'enceinte du produit qui pourrait être d'ampleur suffisante pour présenter un risque de choc électrique.



CAUTION A/V/S
RISK OF ELECTRIC SHOCK
DO NOT OPEN

**RISQUE DE CHOC ELECTRIQUE
NE PAS OUVRIR**

Caution: hot surface
Attention: surface chaude



The exclamation point within an equilateral triangle is intended to alert the user to the presence of important operating and maintenance (servicing) instructions in the literature accompanying the appliance.

Le point d'exclamation à l'intérieur d'un triangle équilatéral est prévu pour alerter l'utilisateur de la présence d'instructions importantes dans la littérature accompagnant l'appareil en ce qui concerne l'opération et la maintenance de cet appareil.

FOLLOW ALL INSTRUCTIONS

Instructions pertaining to a risk of fire, electric shock, or injury to a person

CAUTION: TO REDUCE THE RISK OF ELECTRIC SHOCK, DO NOT REMOVE COVER (OR BACK).

NO USER SERVICEABLE PARTS INSIDE.

REFER SERVICING TO QUALIFIED SERVICE PERSONNEL.

THIS DEVICE IS FOR INDOOR USE ONLY!

SUIVEZ TOUTES LES INSTRUCTIONS

Instructions relatives au risque de feu, choc électrique, ou blessures aux personnes

AVIS: AFIN DE REDUIRE LES RISQUE DE CHOC ELECTRIQUE, N'ENLEVEZ PAS LE COUVERT (OU LE PANNEAU ARRIERE)

NE CONTIENT AUCUNE PIECE REPARABLE PAR L'UTILISATEUR.

CONSULTEZ UN TECHNICIEN QUALIFIE POUR L'ENTRETIEN

CE PRODUIT EST POUR L'USAGE A L'INTERIEUR SEULEMENT

Read Instructions: The Owner's Manual should be read and understood before operation of your unit. Please, save these instructions for future reference and heed all warnings.

Clean only with dry cloth.

Packaging: Keep the box and packaging materials, in case the unit needs to be returned for service.

Warning: To reduce the risk of fire or electric shock, do not expose this apparatus to rain or moisture. *Do not use this apparatus near water!*

Warning: When using electric products, basic precautions should always be followed, including the following:

Power Sources

Your unit should be connected to a power source only of the voltage specified in the owners manual or as marked on the unit. This unit has a polarized plug. Do not use with an extension cord or receptacle unless the plug can be fully inserted. Precautions should be taken so that the grounding scheme on the unit is not defeated. An apparatus with CLASS I construction shall be connected to a Mains socket outlet with a protective earthing ground. Where the MAINS plug or an appliance coupler is used as the disconnect device, the disconnect device shall remain readily operable.

Hazards

Do not place this product on an unstable cart, stand, tripod, bracket or table. The product may fall, causing serious personal injury and serious damage to the product. Use only with cart, stand, tripod, bracket, or table recommended by the manufacturer or sold with the product. Follow the manufacturer's instructions when installing the product and use mounting accessories recommended by the manufacturer. Only use attachments/accessories specified by the manufacturer Note: Prolonged use of headphones at a high volume may cause health damage on your ears.

The apparatus should not be exposed to dripping or splashing water; no objects filled with liquids should be placed on the apparatus.

Terminals marked with the "lightning bolt" are hazardous live; the external wiring connected to these terminals require installation by an instructed person or the use of ready made leads or cords.

Ensure that proper ventilation is provided around the appliance. Do not install near any heat sources such as radiators, heat registers, stoves, or other apparatus (including amplifiers) that produce heat.

No naked flame sources, such as lighted candles, should be placed on the apparatus.

Power Cord

Do not defeat the safety purpose of the polarized or grounding-type plug. A polarized plug has two blades with one wider than the other. A grounding type plug has two blades and a third grounding prong. The wide blade or the third prong are provided for your safety. If the provided plug does not fit into your outlet, consult an electrician for replacement of the obsolete outlet. The AC supply cord should be routed so that it is unlikely that it will be damaged. Protect the power cord from being walked on or pinched particularly at plugs. If the AC supply cord is damaged DO NOT OPERATE THE UNIT. To completely disconnect this apparatus from the AC Mains, disconnect the power supply cord plug from the AC receptacle. The mains plug of the power supply cord shall remain readily operable.

Unplug this apparatus during lightning storms or when unused for long periods of time.

Service

The unit should be serviced only by qualified service personnel. Servicing is required when the apparatus has been damaged in any way, such as power-supply cord or plug is damaged, liquid has been spilled or objects have fallen into the apparatus, the apparatus has been exposed to rain or moisture, does not operate normally, or has been dropped.

Veillez Lire le Manuel: Il contient des informations qui devraient étre comprises avant l'opération de votre appareil.

Conservez. Gardez S.V.P. ces instructions pour consultations ultérieures et observez tous les avertissements.

Nettoyez seulement avec le tissu sec.

Emballage: Conservez la boîte au cas ou l'appareil devait étre retourner pour réparation.

Avertissement: Pour réduire le risque de feu ou la décharge électrique, n'exposez pas cet appareil à la pluie ou à l'humidité. *N'utilisez pas cet appareil près de l'eau!*

Attention: Lors de l'utilisation de produits électrique, assurez-vous d'adhérer à des précautions de bases incluant celle qui suivent:

Alimentation

L'appareil ne doit étre branché qu'à une source d'alimentation correspondant au voltage spécifié dans le manuel ou tel qu'indiqué sur l'appareil. Cet appareil est équipé d'une prise d'alimentation polarisée. Ne pas utiliser cet appareil avec un cordon de raccordement à moins qu'il soit possible d'insérer complètement les trois lames. Des précautions doivent étre prises afin d'éviter que le système de mise à la terre de l'appareil ne soit désengagé. Un appareil construit selon les normes de CLASS I devrait étre raccordé à une prise murale d'alimentation avec connexion intacte de mise à la masse. Lorsqu'une prise de branchement ou un coupleur d'appareils est utilisée comme dispositif de débranchement, ce dispositif de débranchement devra demeurer pleinement fonctionnel avec raccordement à la masse.

Risque

Ne pas placer cet appareil sur un chariot, un support, un trépied ou une table instables. L'appareil pourrait tomber et blesser quelqu'un ou subir des dommages importants. Utiliser seulement un chariot, un support, un trépied ou une table recommandés par le fabricant ou vendus avec le produit. Suivre les instructions du fabricant pour installer l'appareil et utiliser les accessoires recommandés par le fabricant. Utilisez seulement les attaches/accessoires indiqués par le fabricant Note: L'utilisation prolongée des écouteurs à un volume élevé peut avoir des conséquences néfastes sur la santé sur vos oreilles. .

Il convient de ne pas placer sur l'appareil de sources de flammes nues, telles que des bougies allumées.

L'appareil ne doit pas étre exposé à des égouttements d'eau ou des éclaboussures et qu'aucun objet rempli de liquide tel que des vases ne doit étre placé sur l'appareil.

Assurez que l'appareil est fourni de la propre ventilation. Ne procédez pas à l'installation près de source de chaleur tels que radiateurs, registre de chaleur, fours ou autres appareils (incluant les amplificateurs) qui produisent de la chaleur.

Les dispositifs marqués d'un symbole "d'éclair" sont des parties dangereuses au toucher et que les câblages extérieurs connectés à ces dispositifs de connection extérieure doivent étre effectués par un opérateur formé ou en utilisant des cordons déjà préparés.

Cordon d'Alimentation

Ne pas enlever le dispositif de sécurité sur la prise polarisée ou la prise avec tige de mise à la masse du cordon d'alimentation. Une prise polarisée dispose de deux lames dont une plus large que l'autre. Une prise avec tige de mise à la masse dispose de deux lames en plus d'une troisième tige qui connecte à la masse. La lame plus large ou la tige de mise à la masse est prévu pour votre sécurité. La prise murale est désuète si elle n'est pas conçue pour accepter ce type de prise avec dispositif de sécurité. Dans ce cas, contactez un électricien pour faire remplacer la prise murale. Évitez d'endommager le cordon d'alimentation. Protégez le cordon d'alimentation. Assurez-vous qu'on ne marche pas dessus et qu'on ne le pince pas en particulier aux prises. **N'UTILISEZ PAS L'APPAREIL** si le cordon d'alimentation est endommagé. Pour débrancher complètement cet appareil de l'alimentation CA principale, déconnectez le cordon d'alimentation de la prise d'alimentation murale. Le cordon d'alimentation du bloc d'alimentation de l'appareil doit demeurer pleinement fonctionnel.

Débranchez cet appareil durant les orages ou si utilisé pendant de longues périodes.

Service

Consultez un technicien qualifié pour l'entretien de votre appareil. L'entretien est nécessaire quand l'appareil a été endommagé de quelque façon que se soit. Par exemple si le cordon d'alimentation ou la prise du cordon sont endommagés, si il y a eu du liquide qui a été renversé à l'intérieur ou des objets sont tombés dans l'appareil, si l'appareil a été exposé à la pluie ou à l'humidité, si il ne fonctionne pas normalement, ou a été échappé.

IMPORTANT SAFETY INSTRUCTIONS (UL60065)



The Lightning Flash with arrowhead symbol within an equilateral triangle, is intended to alert the user to the presence of uninsulated "dangerous voltage" within the product enclosure that may be of sufficient magnitude to constitute a risk of shock to persons



The exclamation point within an equilateral triangle is intended to alert the user to the presence of important operating and maintenance (servicing) instructions in the literature accompanying the product



Le symbole représentant un éclair avec une flèche à l'intérieur d'un triangle équilatéral est utilisé pour prévenir l'utilisateur de la présence d'une tension électrique dangereuse non isolée à l'intérieur de l'appareil. Cette tension est d'un niveau suffisamment élevé pour représenter un risque d'électrocution



Le symbole représentant un point d'exclamation à l'intérieur d'un triangle équilatéral, signale à l'utilisateur la présence d'instructions importantes relatives au fonctionnement et à l'entretien de l'appareil dans cette notice d'installation

1. Read these instructions.
2. Keep these instructions.
3. Heed all warnings.
4. Follow all instructions.
5. Do not use this apparatus near water.
6. Clean only with dry cloth.
7. Do not block any ventilation openings. Install in accordance with the manufacturer's instructions.
8. Do not install near any heat sources such as radiators, heat registers, stoves, or other apparatus (including amplifiers) that produce heat.
9. Do not defeat the safety purpose of the polarized or grounding-type plug. A polarized plug has two blades with one wider than the other. A grounding type plug has two blades and a third grounding prong. The wide blade or the third prongs are provided for your safety. If the provided plug does not fit into your outlet, consult an electrician for replacement of the obsolete outlet.
10. Protect the power cord from being walked on or pinched particularly at plugs, convenience receptacles, and the point where they exit from the apparatus.
11. Only use attachments/accessories specified by the manufacturer.
12. Use only with the cart, stand, tripod, bracket, or table specified by the manufacturer, or sold with the apparatus. When a cart is used, use caution when moving the cart/apparatus combination to avoid injury from tip-over.
13. Unplug this apparatus during lightning storms or when unused for long periods of time.
14. Refer all servicing to qualified service personnel. Servicing is required when the apparatus has been damaged in any way, such as power-supply cord or plug is damaged, liquid has been spilled or objects have fallen into the apparatus, the apparatus has been exposed to rain or moisture, does not operate normally, or has been dropped.

WARNING:

- To reduce the risk of fire or electric shock, do not expose this apparatus to rain or moisture and objects filled with liquids, such as vases, should not be placed on this apparatus.
- To completely disconnect this apparatus from the ac mains, disconnect the power supply cord plug from the ac receptacle.
- The mains plug of the power supply cord or appliance coupler shall remain readily accessible.

1. Lisez ces instructions.
2. Conservez ces instructions.
3. Respecter tous les avertissements.
4. Suivez toutes les instructions.
5. N'utilisez pas l'appareil près de l'eau.
6. Nettoyer uniquement avec chiffon sec.
7. Ne bloquez pas les ouvertures de ventilation. Installer en suivant les instructions du fabricant.
8. Ne pas installer près des sources de chaleur telles que radiateurs, bouches de chaleur, four ou autres appareils (y compris les amplificateurs) produisant de la chaleur.
9. N'annulez pas l'objectif sécuritaire de la fiche polarisée ou de la tige de mise à la terre. Une fiche polarisée possède deux lames avec une plus large que l'autre. Une prise avec mise à la terre possède deux lames et une troisième tige. La lame large ou la troisième tige sont fournis pour votre sécurité. Si la fiche n'entre pas dans votre prise, consultez un électricien pour remplacer la prise obsolète.
10. Protéger le cordon d'alimentation des piétinements ou pincements en particulier près des fiches, des prises de courant et au point de sortie de l'appareil.
11. Utilisez uniquement les accessoires spécifiés par le fabricant.
12. Utiliser uniquement avec un charriot, stand, trépied ou une table spécifiée par le fabricant, ou vendus avec l'appareil.
13. Débranchez l'appareil durant un orage ou lorsqu'il reste inutilisé pendant de longues périodes de temps.
14. Confiez toute réparation à un technicien qualifié. Une réparation est nécessaire lorsque l'appareil a été endommagé de quelque façon que ce soit; comme lorsque le cordon d'alimentation ou la fiche est endommagé, lorsque du liquide a été renversé ou des objets sont tombés à l'intérieur, lorsque l'appareil a été exposé à la pluie ou l'humidité, ne fonctionne pas normalement, ou est tombé.

AVERTISSEMENT:

- Pour réduire les risques d'incendie ou de choc électrique, ne pas exposer cet appareil à la pluie ou à l'humidité et ne placez pas d'objets contenant des liquides, tels que des vases, sur l'appareil.
- Pour isoler totalement cet appareil de l'alimentation secteur, débranchez totalement son cordon d'alimentation du réceptacle CA.
- La prise du cordon d'alimentation ou du prolongateur, si vous en utilisez un comme dispositif de débranchement, doit rester facilement accessible



CAUTION
TO PREVENT ELECTRIC SHOCK HAZARD,
DO NOT CONNECT TO MAINS POWER SUPPLY
WHILE GRILLE IS REMOVED.



AVIS
POUR PRÉVENIR LES RISQUES D'ÉLECTROCUTION,
NE PAS RACCORDER A L'ALIMENTATION ÉLECTRIQUE ALORS
QUE LA GRILLE EST RETIRÉE.



Block Diagram for M810 / M1610

DESIGNED & MANUFACTURED BY YORKVILLE SOUND

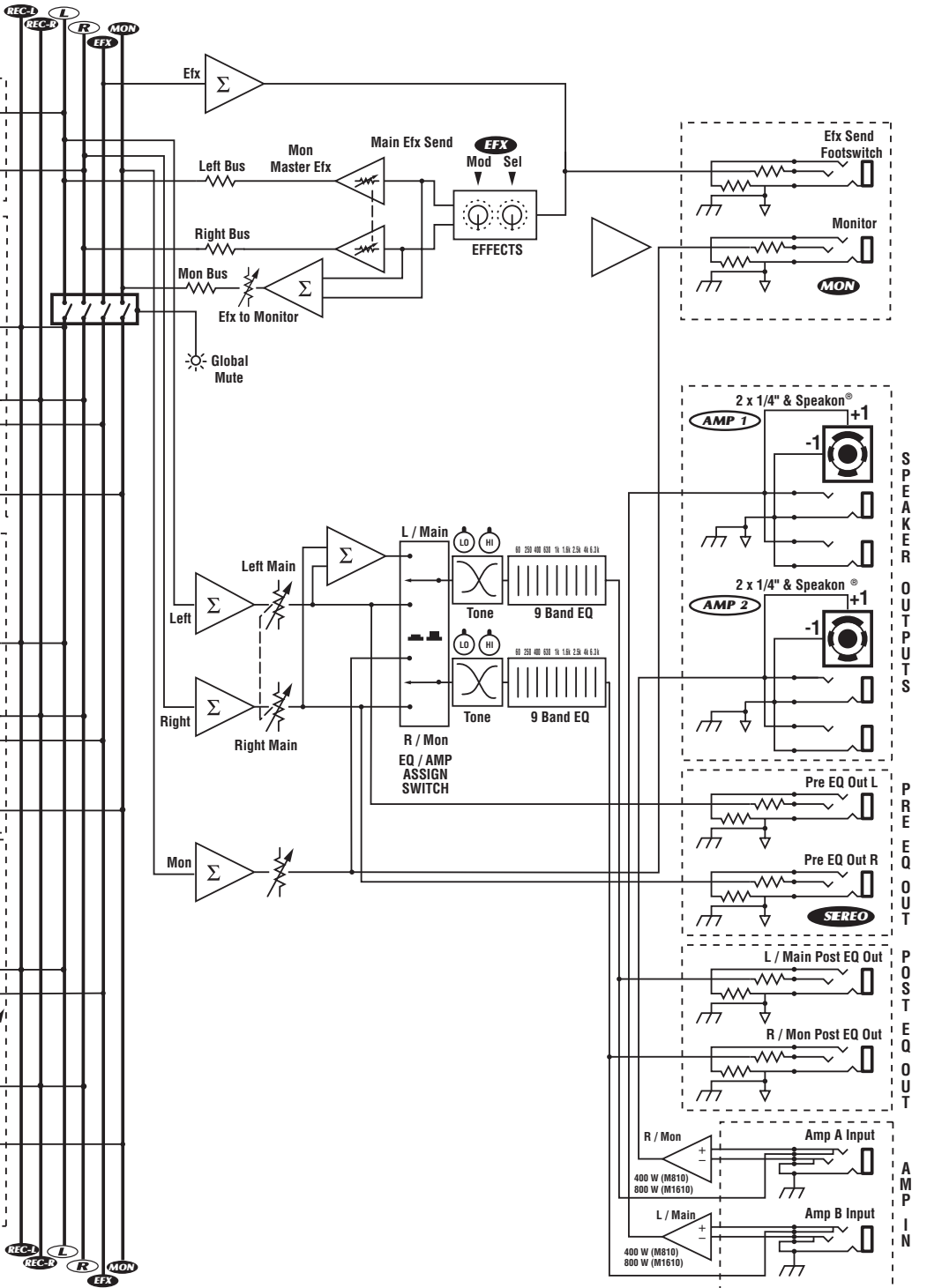
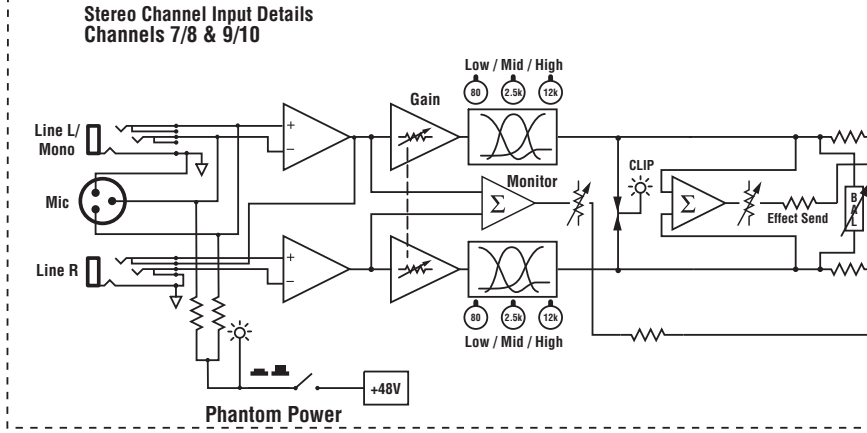
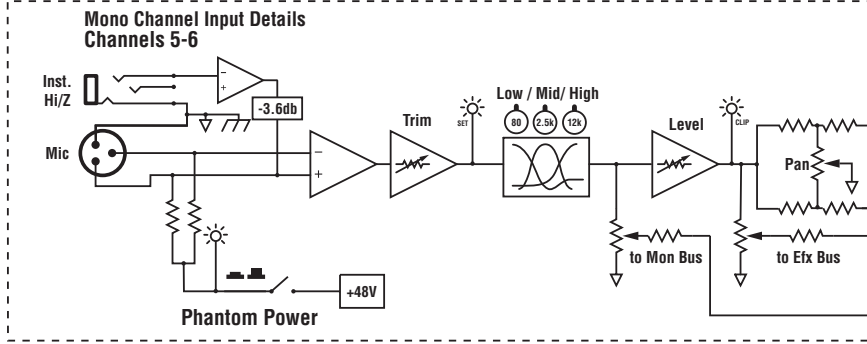
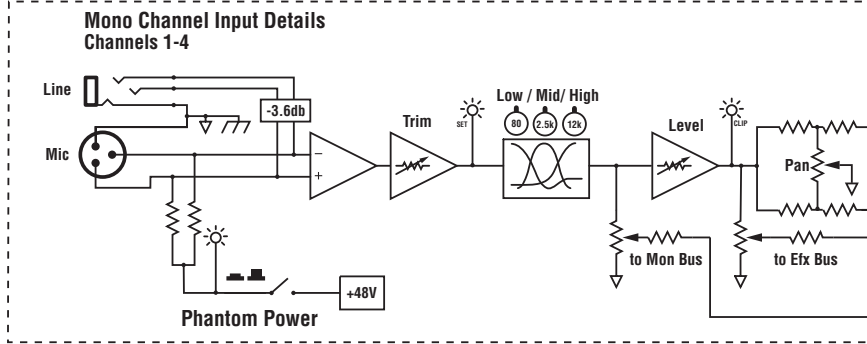
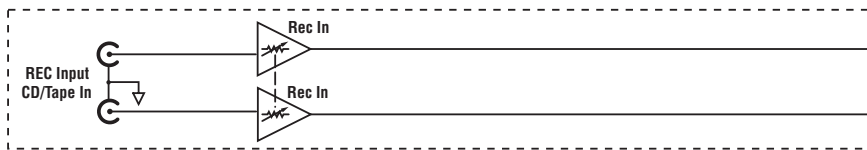



m810/m1610 Powered Wedge Mixer

#	Part#	Description
Labeled Components		
1	8497	M1610/M810 GABLE
2	8893	10-32 X 1 FLAT PHILIPS TT JS500 BLK BOLTS
3	3628	SPKON 4C PCB MT VERT 250TAB GRY
4	8637/3522	PUSHBUTTON 1/4" BLK / DPDT MINI PC VERT
5	3924	1/4" JCK PCB MT VERT 2XTIP HICU
6	9916	GRY SOFT GRAY RIB KNOB 0-DEG
7	9918	BLU SOFT GRAY RIB KNOB 0-DEG
8	9917	GRN SOFT GRAY RIB KNOB 0-DEG
9	9919	YEL SOFT GRAY RIB KNOB 0-DEG
10	9920	WHT SOFT GRAY RIB KNOB 0-DEG
11	9921	GREY KNB W/O COVERING 0-DEG
12	8397	GREY STYLE 2 KNOB
13	8632	ROUND PUSH BUTTON 1/4" GREY
14	4010	XLR FEML PCB MT VERT 24MM AA-SE
15	3466	RCA DUAL PCB MT VERT GOLD 24MM
16	3450 & 3450NUT	1/4" ALL GOLD PC MNT JK SKT
17	2408/2456	8.0a CIR BREAKER (CE = 4.0A CIR BREAKER)
18	3587	DPDT ROKR SW QUIK 250°AC/PWR ON
19	3663	SNAP IEC PWR SOC W/250TAB
20	3426	8' 3/16 SJT AC LINE CORD REMOV-B-SEA
21	3474	6' 3X.075MM AC LINE CORD EURO-REMOV

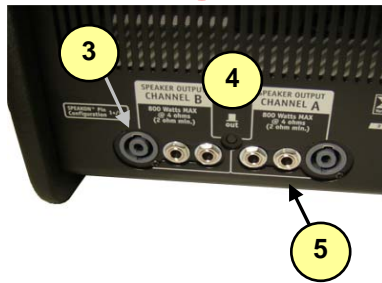
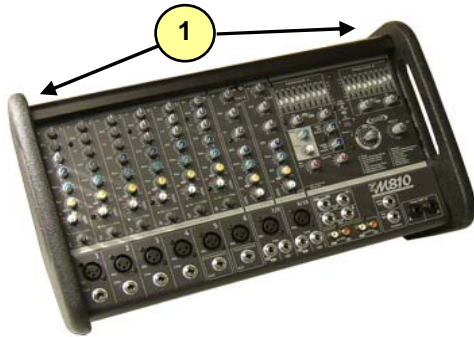

EURO PWR CORD

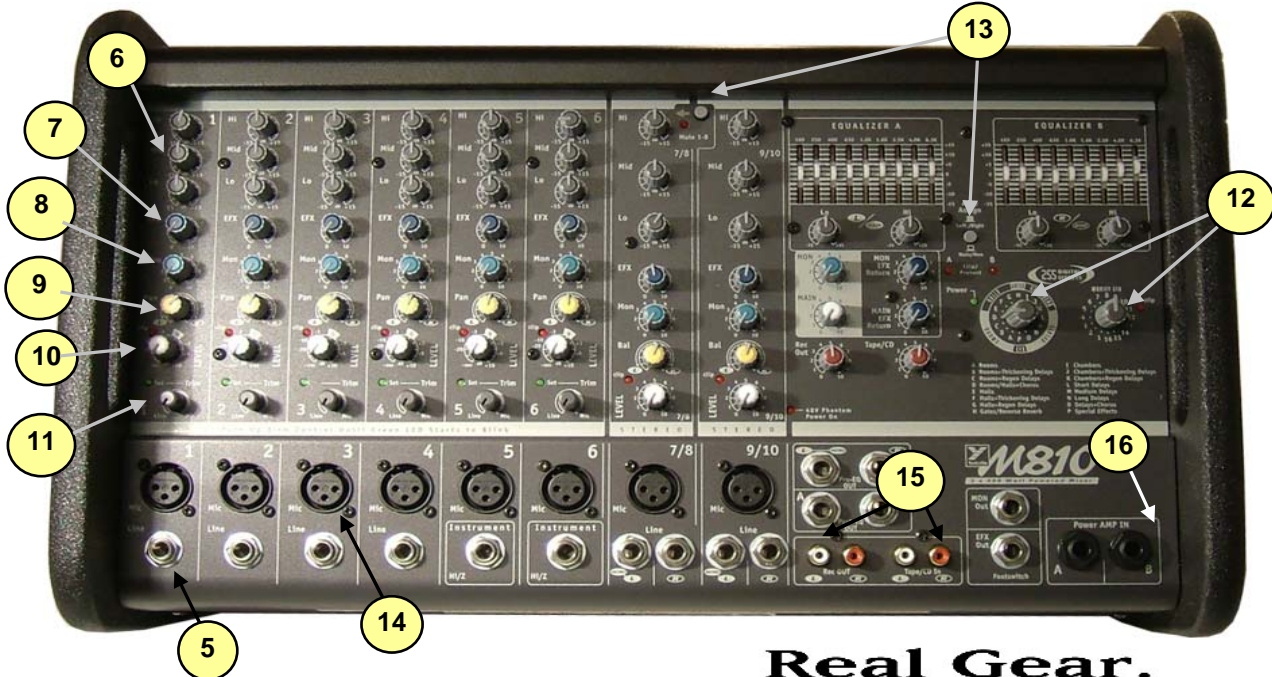

**Real Gear.
Real People.**

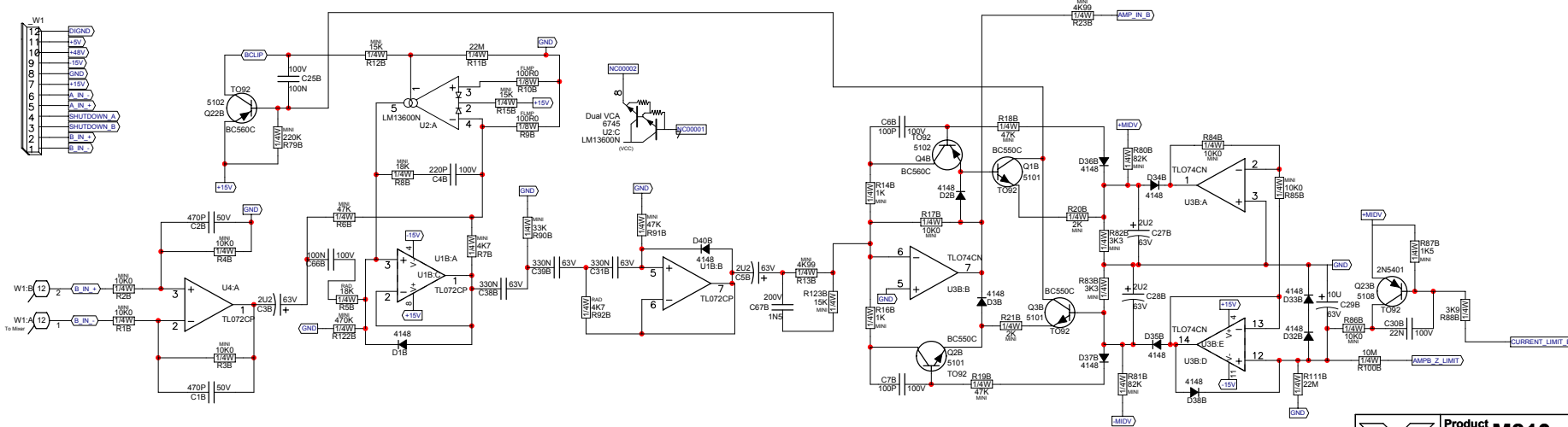
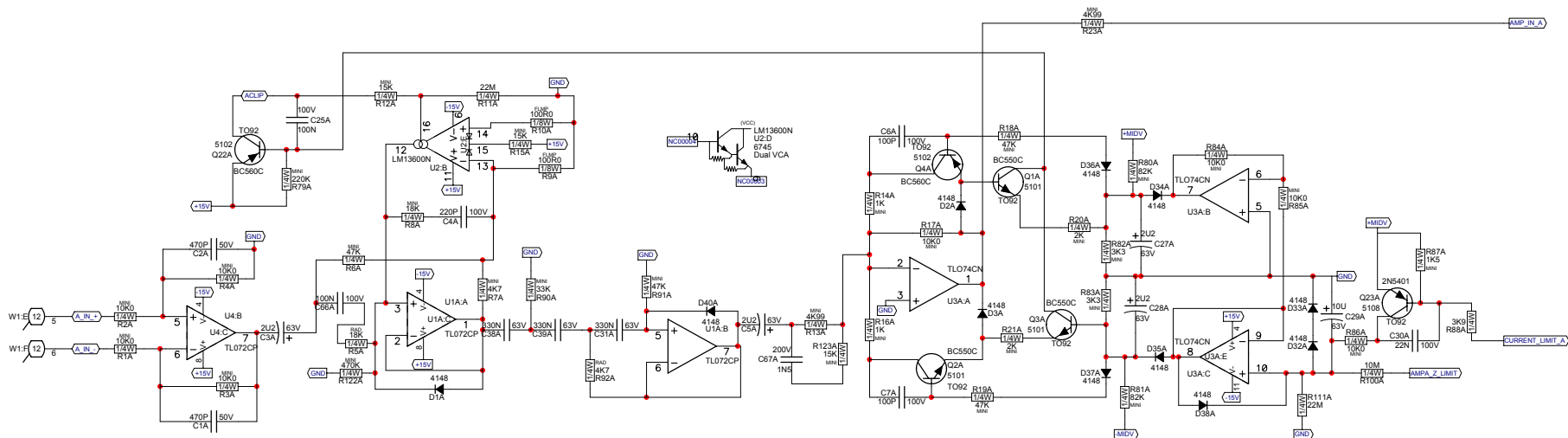

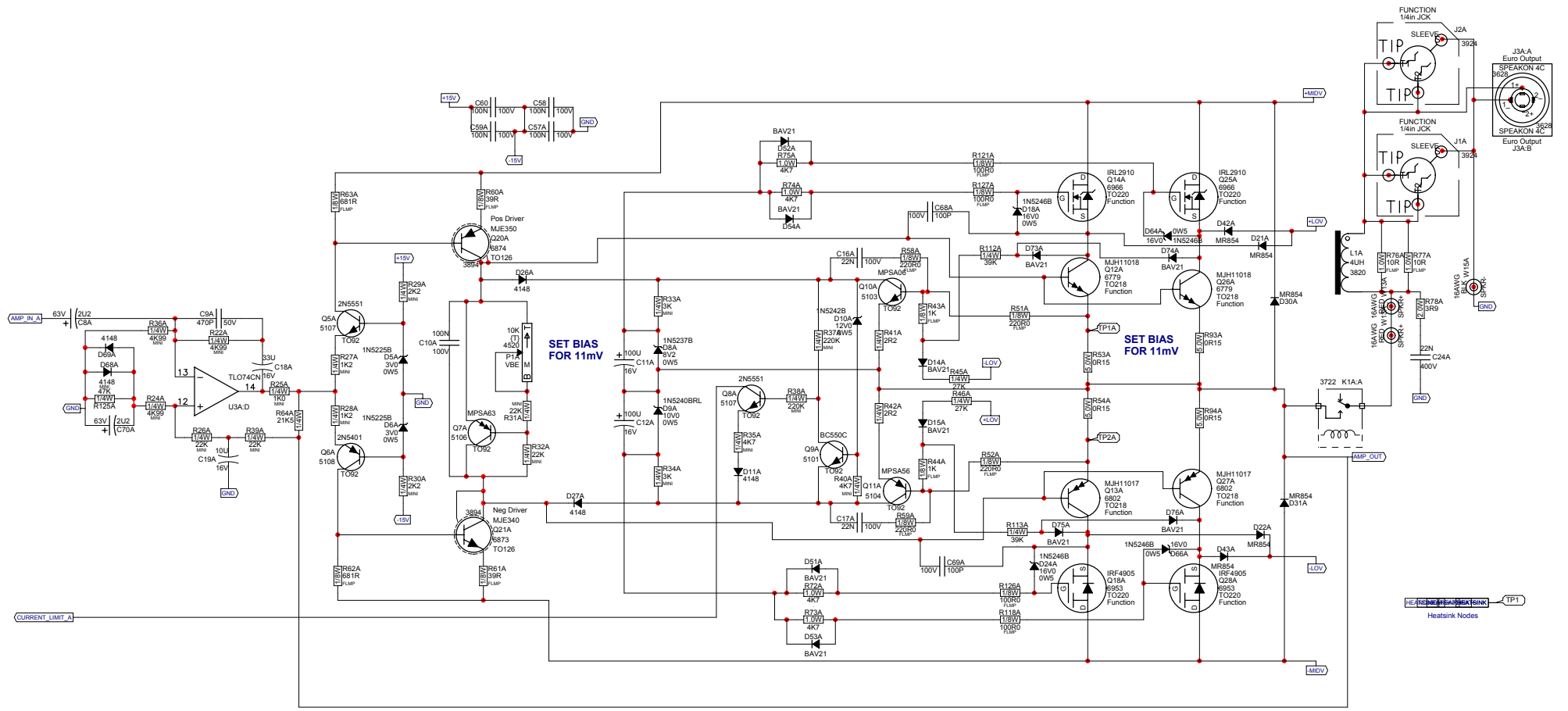

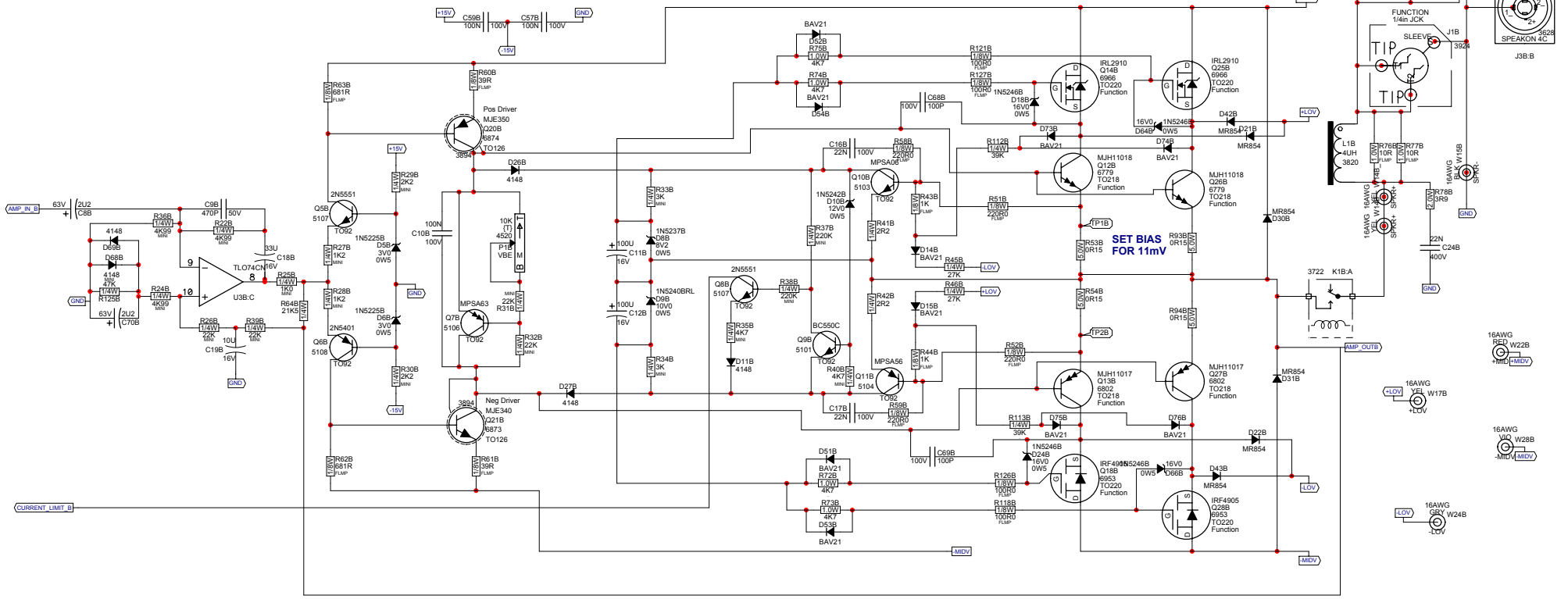

SET BIAS
FOR 11mV



Product M810 Amp B		
Channel B	PCB# M1194	Sheet 3 of 5
Date: Wed Jun 28, 2006	Rev: 7V00	YsType: (Company)
Filename: M1194-7V00sch.2002		

M1194.PCB_DATABASE_HISTORY			#	DATE	VER#	DESCRIPTION OF CHANGE
MODEL(S):- M810			24			35V AND C36&C37#58964700/80V->#5898 8200U/50V
			25			UPDATED BIAS NOTE TO READ 11mV R45A/B&R46A/B
			26			#4890 30K->#4833 27K, R112A/B&R113A/B #4868 36K->
			27			#4853 39K, C25A/B #5224 47N/100V->#5212 100N/63V,
			28			R79A/B #6127 470K->#6128 220K, SWAPPED W8 AND W35
			29	19-JUN-2006	7.00	LAH, PC#6983, WIDEN TRACE BETWEEN C32 AND C37
			30			PC#7091, ENLARGE HOLE SIZE FOR #3522
			31			
			32			
			33			
			34			
			35			
			36			
			37			
			38			
			39			
			40			
			41			
			42			
			43			
			44			
			45			
			46			
			47			
			48			
			49			
			50			

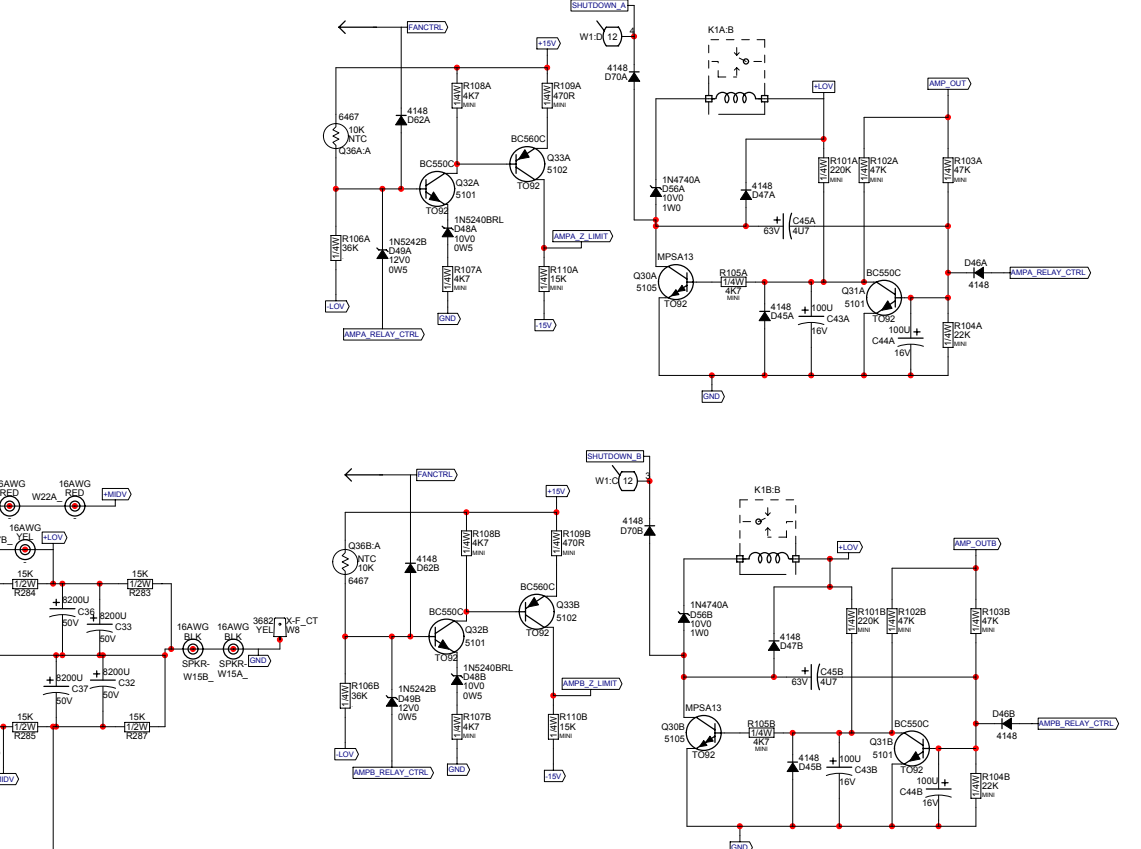
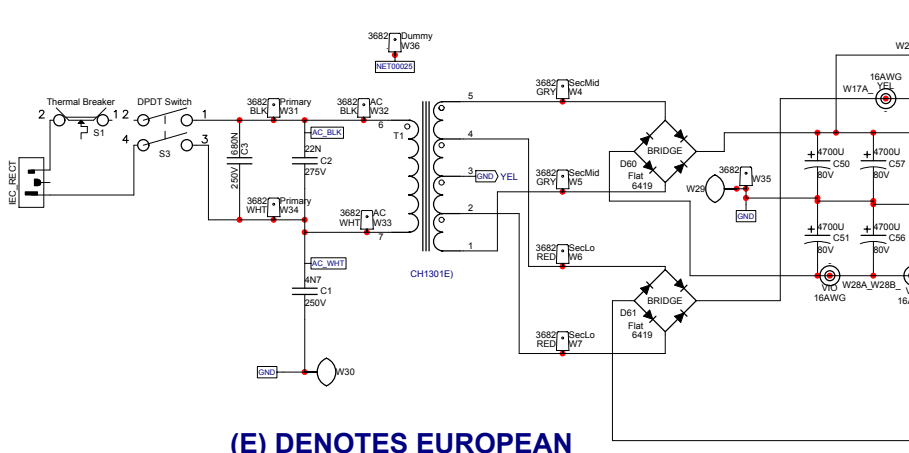
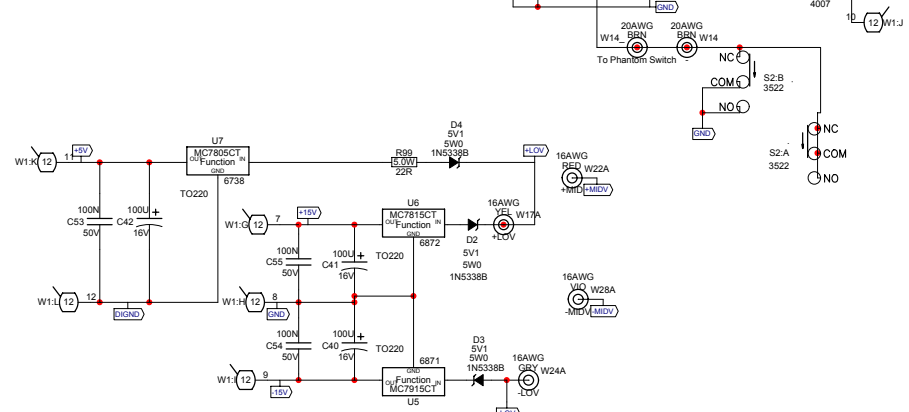
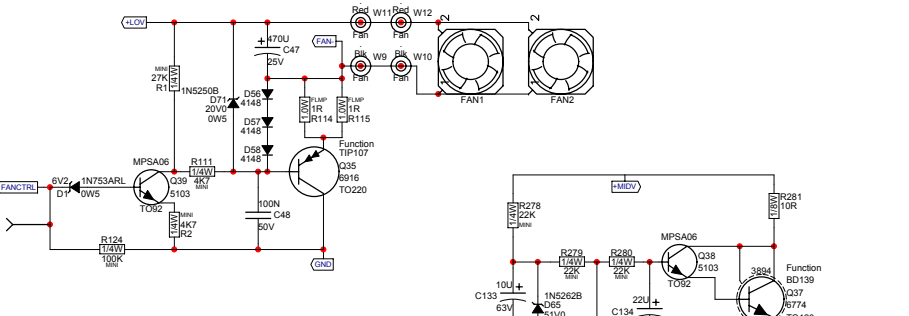

(E) DENOTES EUROPEAN



Product M810		
Power Supply	PCB# M1194	Sheet 4 of 5
Date: Wed Jun 28, 2006	Rev: 7V00	YsType: (Company)
Filename: M1194-7V00sch.2002		

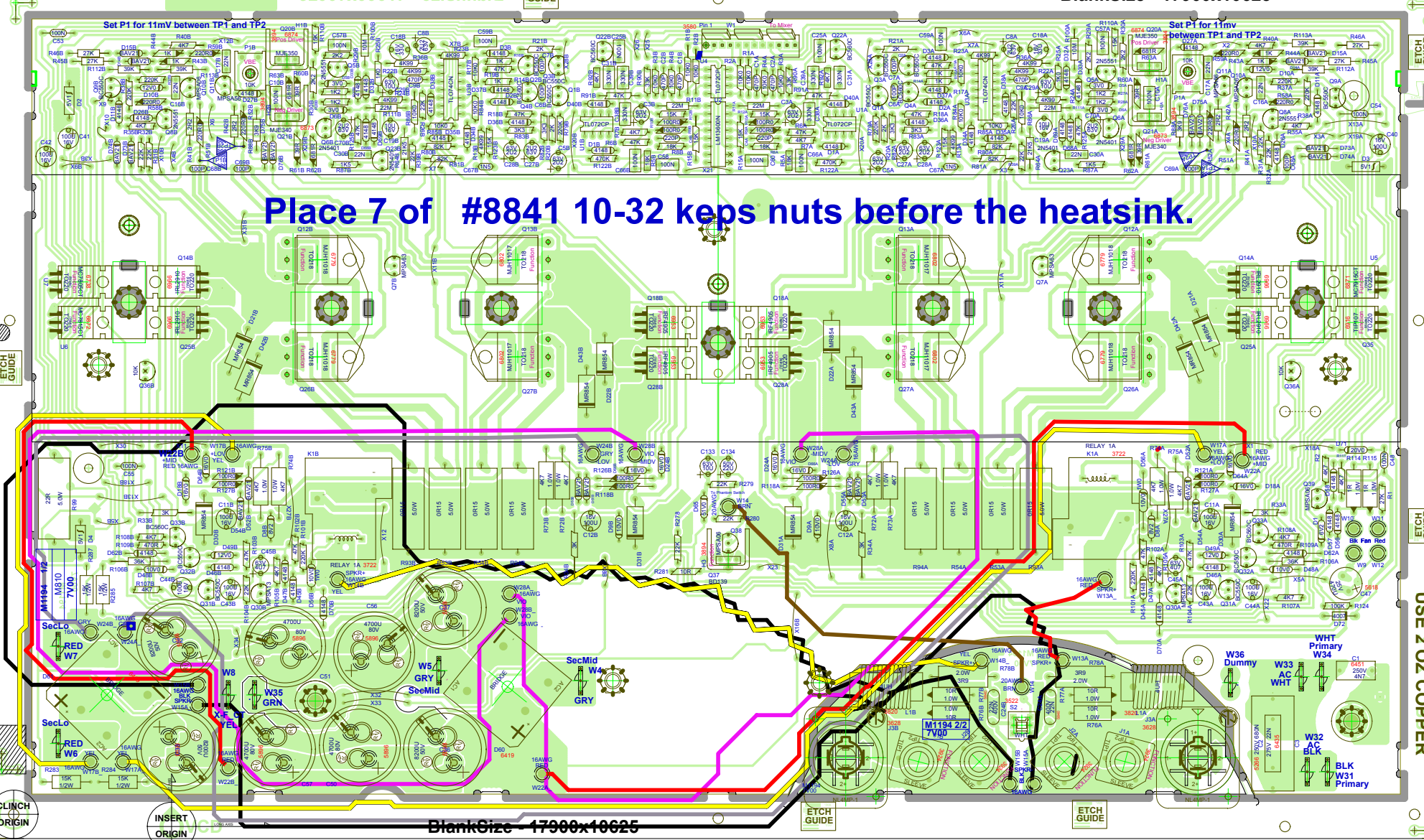

Place 7 of #8841 10-32 keps nuts before the heatsink.



SEE LAYOUT DIAGRAM



M1194.PCB_DATABASE_HISTORY				#	DATE	VER#	DESCRIPTION OF CHANGE
MODEL(S):- M810				24	.	.	35V AND C36&C37#58964700/80V->#5898 8200U/50V
				25	.	.	UPDATED BIAS NOTE TO READ 11mV, R45A/B&R46A/B
				26	.	.	#4890 30K->#4833 27K, R112A/B&R113A/B #4868 36K->
				27	.	.	#4853 39K, C25A/B #5224 47N/100V->#5212 100N/63V,
				28	.	.	R79A/B #6127 470K->#6126 220K, SWAPPED W8 AND W35
				29	19-JUN-2006	7.00	AH, PC#6983, WIDEN TRACE BETWEEN C32 AND C37
				30	.	.	PC#7091, ENLARGE HOLE SIZE FOR #3522
#	DATE	VER#	DESCRIPTION OF CHANGE				
1	10 Jan, 2004	1.00	Rationalize wire refdes				
2	24 Feb, 2004	1.00	Add speakon jacks to output section				
3	10 Mar, 2004	1.00	Enlarge cutouts for 8841 nuts				
4	1-APR-2004	1.10	PC#6674 Change R31A,B 15k-->22k (4979-->6118)				
5	15-APR-2004	1.20	PC#6678 Chg. R5A,B 6k8->18k; R82A,B 5k6->3k3				
6			R83A,B 56k->3k3; R80A,B, R81A,B 133k->100k				
7	21-APR-2004	1.20	PC#6681 Modified route to let grn wire pass near power				
8	6-MAY-2004	2.00	PC#6685 R80&R81(A,B) 100K->82K, ADDED D71, D72				
9	JUN/17/2004	2.10	PC# 6707 Q12 (A+B) Q26 (A+B) TIP142 -> MJH11018				
10			Q13 (A+B), Q27 (A+B) TIP147 -> MJH11017				
11	13 Sept, 2004	2.11	TC:PC#6763:Moved HS alignment hole to match HS				
12	JAN-05-2005	4.00	PC#6808 R72,R73,R74,R75 FROM 10K0 1W TO 4K7 1W				
13			D8 A/B 12V0 TO 8V2, D9A/B 14V0 TO 10V0, D10A/B 16V0				
14			TO 12V0. ADD R112A/B, R113A/B (36K), D73A/B, D74A/B				
15			D75A/B, D76A/B (BAV21). R45A/B, R46A/B 36K TO 30K				
16			REMOVE D16,D17,R47,R48,R49, R50 (ALL A/B)				
17			ADD JUMPERS X1 TO X12				
18			PC#6794: AC CLEARANCE FIX				
19	MAR-24-2005	5.00	FIXED MASK SPREAD TO 30MIL				
20	APR-13-2005	5.10	CHANGE IRF3205 #6954 TO IRL2910 #6966				
21			PLACE MICA UNDER MIDDLE TIER MOSFETS				
22	JUN-29-2005	6.00	PC#6920:GT:R106A/B #6122 33K->#4868 36K, D56A/B				
23			#6440 4V7/0W5->#6484 10V1W, C32&C33#5903 12000U/				
DRILL & ROUTE HISTORY				M1194 PENDING CHANGES			
MODEL(S):- M810				MODEL(S):- M810			
#	DATE	VER#	DESCRIPTION OF CHANGE	#	PC#		PENDING CHANGE
1	10-MAR-2004	V02	Enlarged routing for hex nuts	1	PC	X	
2	5-MAY-2004	V03	Added notch to routing to pass GRN wire from front	2	PC	X	
3	6-MAY-2004	V04	To match v2.00 changes	3	PC	X	
4	JAN-05-2005	V05	PC#6763 MOVE TOP LEFT HEATSINK LINE-UP HOLE	4	PC	X	
5	20 Apr,2005	5.11	Corrected 'BlankSize' field for clinch program	5	PC	X	
6			Corrected pad orientations on 4520, 5840 and 3722	6	PC	X	
7	D	V	N				
8	D	V	N				
9	D	V	N				
10	D	V	N				
11	D	V	N				
12	D	V	N				
13	D	V	N				

*PLACE IMPLEMENTED CHANGES INTO BOARD HISTORY

PRODUCTION NOTES

1. Use three 8832 screws to align and attach the heatsinks to the board.
2. When assembling heatsinks to Q20(A&B),Q21(A&B),Q37, ensure heatsinks are straight and sit flat against board. Add a very small amount of RTV between heatsink and board if necessary. This prevent heatsink from shorting other components.
3. Add grease under middle tier mosfets.

4XTO220-MTG

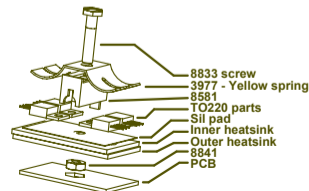

2XTO218-MTG

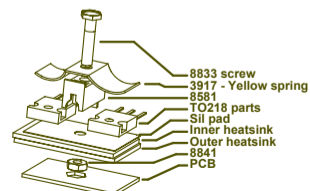



STEREO DIGITAL EFFECTS

YORKVILLE SOUND • DIGITAL EFFECTS BY A.R.T.

A ROOMS

- 1 0.5s Bright Small Room
- 2 0.5s Warm Small Room
- 3 0.5s Dark Small Room
- 4 0.8s Bright Small Room
- 5 0.8s Warm Small Room
- 6 1.0s Bright Small Room
- 7 1.0s Warm Small Room
- 8 1.2s Bright Medium Room
- 9 1.2s Warm Medium Room
- 10 1.5s Bright Medium Room
- 11 1.5s Warm Medium Room
- 12 1.5s Dark Medium Room
- 13 2.0s Bright Large Room
- 14 2.0s Warm Large Room
- 15 2.5s Bright Large Room
- 16 2.5s Warm Large Room

B ROOMS & THICKENING DELAYS

- 1 0.5s Bright Small Room + 50ms doubling delay
- 2 0.5s Warm Small Room + 40ms doubling delay
- 3 0.5s Dark Small Room + 40ms doubling delay
- 4 0.8s Bright Small Room + 60ms doubling delay
- 5 0.8s Warm Small Room + 50ms doubling delay
- 6 1.0s Bright Small Room + 70ms slap delay
- 7 1.0s Warm Small Room + 50ms doubling delay
- 8 1.2s Bright Medium Room + 50ms doubling delay
- 9 1.2s Warm Medium Room + 50ms doubling delay
- 10 1.5s Bright Medium Room + 80ms slap delay
- 11 1.5s Warm Medium Room + 60ms doubling delay
- 12 1.5s Dark Medium Room + 70ms slap delay
- 13 2.0s Bright Large Room + 80ms slap delay
- 14 2.0s Warm Large Room + 60ms doubling delay
- 15 2.5s Bright Large Room + 100ms slap delay
- 16 2.5s Warm Large Room + 80ms slap delay

C ROOMS & REGENERATION DELAYS

- 1 0.5s Bright Small Room + 200ms regen delay
- 2 0.5s Warm Small Room + 175ms regen delay
- 3 0.5s Dark Small Room + 150ms regen delay
- 4 0.8s Bright Small Room + 200ms regen delay
- 5 0.8s Warm Small Room + 150ms regen delay
- 6 1.0s Bright Small Room + 175ms regen delay
- 7 1.0s Warm Small Room + 125ms regen delay
- 8 1.2s Bright Medium Room + 150ms regen delay
- 9 1.2s Warm Medium Room + 200ms regen delay
- 10 1.5s Bright Medium Room + 200ms regen delay
- 11 1.5s Warm Medium Room + 175ms regen delay
- 12 1.5s Dark Medium Room + 150ms regen delay
- 13 2.0s Bright Large Room + 200ms regen delay
- 14 2.0s Warm Large Room + 125ms regen delay
- 15 2.5s Bright Large Room + 150ms regen delay
- 16 2.5s Warm Large Room + 200ms regen delay

D ROOMS / HALLS & CHORUS

- 1 0.5s Bright Room + slow chorus
- 2 0.8s Warm Room + medium chorus
- 3 1.0s Bright Room + slow chorus
- 4 1.2s Warm Room + medium chorus
- 5 1.5s Bright Room + slow chorus
- 6 1.8s Warm Room + slow chorus
- 7 2.5s Bright Room + medium chorus
- 8 3.0s Warm Room + slow chorus
- 9 2.0s Bright Hall + slow chorus
- 10 2.5s Warm Hall + medium chorus
- 11 2.5s Bright Hall + slow chorus
- 12 3.0s Warm Hall + slow chorus
- 13 3.5s Warm Hall + slow chorus
- 14 3.5s Bright Hall + medium chorus
- 15 5.0s Warm Hall + slow chorus
- 16 8.0s Warm Hall + slow chorus

E HALLS

- 1 1.5s Dark Medium Hall
- 2 1.5s Warm Medium Hall
- 3 1.5s Bright Medium Hall
- 4 2.0s Dark Medium Hall
- 5 2.0s Warm Medium Hall
- 6 2.0s Bright Medium Hall
- 7 2.5s Dark Medium Hall
- 8 2.5s Warm Medium Hall
- 9 2.5s Bright Medium Hall
- 10 3.5s Dark Medium Hall
- 11 3.5s Warm Medium Hall
- 12 3.5s Bright Medium Hall
- 13 5.0s Dark Large Hall
- 14 5.0s Warm Large Hall
- 15 8.0s Dark Huge Hall
- 16 8.0s Warm Huge Hall

F HALLS & THICKENING DELAYS

- 1 1.5s Dark Medium Hall + 50ms doubling delay
- 2 1.5s Warm Medium Hall + 70ms slap delay
- 3 1.5s Bright Medium Hall + 90ms slap delay
- 4 2.0s Dark Medium Hall + 90ms slap delay
- 5 2.0s Warm Medium Hall + 70ms slap delay
- 6 2.0s Bright Medium Hall + 50ms doubling delay
- 7 2.5s Dark Medium Hall + 70ms slap delay
- 8 2.5s Warm Medium Hall + 80ms slap delay
- 9 2.5s Bright Medium Hall + 100ms slap delay
- 10 3.5s Dark Medium Hall + 80ms slap delay
- 11 3.5s Warm Medium Hall + 90ms slap delay
- 12 3.5s Bright Medium Hall + 100ms slap delay
- 13 5.0s Dark Large Hall + 80ms slap delay
- 14 5.0s Bright Large Hall + 100ms slap delay
- 15 8.0s Dark Huge Hall + 100ms slap delay
- 16 8.0s Warm Huge Hall + 100ms slap delay

G HALLS & REGENERATION DELAYS

- 1 1.5s Dark Medium Hall + 150ms regen delay
- 2 1.5s Warm Medium Hall + 175ms regen delay
- 3 1.5s Bright Medium Hall + 200ms regen delay
- 4 2.0s Dark Medium Hall + 200ms regen delay
- 5 2.0s Warm Medium Hall + 150ms regen delay
- 6 2.0s Bright Medium Hall + 175ms regen delay
- 7 2.5s Dark Medium Hall + 200ms regen delay
- 8 2.5s Warm Medium Hall + 150ms regen delay
- 9 2.5s Bright Medium Hall + 175ms regen delay
- 10 3.5s Dark Medium Hall + 125ms regen delay
- 11 3.5s Warm Medium Hall + 150ms regen delay
- 12 3.5s Bright Medium Hall + 200ms regen delay
- 13 5.0s Dark Large Hall + 175ms regen delay
- 14 5.0s Bright Large Hall + 200ms regen delay
- 15 8.0s Dark Huge Hall + 150ms regen delay
- 16 8.0s Bright Large Hall + 200ms regen delay

H GATED / REVERSE REVERB

- 1 0.8s decay 100ms Gate
- 2 0.8s decay 200ms Gate
- 3 1.2s decay 100ms Gate
- 4 1.2s decay 200ms Gate
- 5 1.8s decay 150ms Gate
- 6 1.8s decay 200ms Gate
- 7 2.0s decay 300ms Gate
- 8 2.0s decay 300ms Gate
- 9 2.5s decay 250ms Gate
- 10 2.5s decay 400ms Gate
- 11 0.5s decay 100ms Reverse
- 12 0.5s decay 200ms Reverse
- 13 1.0s decay 100ms Reverse
- 14 1.0s decay 200ms Reverse
- 15 2.5s decay 250ms Reverse
- 16 4.0s decay 300ms Reverse

I CHAMBERS / PLATES

- 1 0.8s Warm Chamber
- 2 0.8s Bright Chamber
- 3 1.2s Warm Chamber
- 4 1.2s Bright Chamber
- 5 1.5s Warm Chamber
- 6 1.5s Bright Chamber
- 7 2.5s Warm Chamber
- 8 2.5s Bright Chamber
- 9 3.5s Warm Chamber
- 10 3.5s Bright Chamber
- 11 0.3s Bright Plate
- 12 0.5s Bright Plate
- 13 0.8s Bright Plate
- 14 1.2s Bright Plate
- 15 1.5s Bright Plate
- 16 2.0s Bright Plate

J CHAMBERS / PLATES + THICKENING DELAYS

- 1 0.8s Warm Chamber + 50ms doubling delay
- 2 0.8s Bright Chamber + 50ms doubling delay
- 3 1.2s Warm Chamber + 60ms doubling delay
- 4 1.2s Bright Chamber + 70ms slap delay
- 5 1.5s Warm Chamber + 70ms slap delay
- 6 1.5s Bright Chamber + 80ms slap delay
- 7 2.5s Warm Chamber + 80ms slap delay
- 8 2.5s Bright Chamber + 100ms slap delay
- 9 3.5s Warm Chamber + 90ms slap delay
- 10 3.5s Bright Chamber + 100ms slap delay
- 11 0.3s Bright Plate + 40ms doubling delay
- 12 0.5s Bright Plate + 50ms doubling delay
- 13 0.8s Bright Plate + 50ms doubling delay
- 14 1.2s Bright Plate + 80ms slap delay
- 15 1.5s Bright Plate + 80ms slap delay
- 16 2.0s Bright Plate + 100ms slap delay

K CHAMBERS / PLATES + REGEN DELAYS

- 1 0.8s Warm Chamber + 150ms regen delay
- 2 0.8s Bright Chamber + 125ms regen delay
- 3 1.2s Warm Chamber + 175ms regen delay
- 4 1.2s Bright Chamber + 200ms regen delay
- 5 1.5s Warm Chamber + 150ms regen delay
- 6 1.5s Bright Chamber + 200ms regen delay
- 7 2.5s Warm Chamber + 175ms regen delay
- 8 2.5s Bright Chamber + 125ms regen delay
- 9 3.5s Warm Chamber + 200ms regen delay
- 10 3.5s Bright Chamber + 150ms regen delay
- 11 0.3s Bright Plate + 125ms regen delay
- 12 0.5s Bright Plate + 150ms regen delay
- 13 0.8s Bright Plate + 200ms regen delay
- 14 1.2s Bright Plate + 175ms regen delay
- 15 1.5s Bright Plate + 150ms regen delay
- 16 2.0s Bright Plate + 200ms regen delay

L SHORT DELAYS

- 1 30ms slap delay
- 2 35ms slap delay
- 3 40ms slap delay
- 4 50ms slap delay
- 5 60ms slap delay
- 6 70ms slap delay
- 7 80ms slap delay
- 8 90ms slap delay
- 9 100ms slap delay
- 10 100ms regen delay
- 11 125ms low regen delay
- 12 125ms medium regen delay
- 13 150ms low regen delay
- 14 150ms medium regen delay
- 15 175ms low regen delay
- 16 175ms medium regen delay

M MEDIUM DELAYS

- 1 200ms low regen delay
- 2 200ms medium regen delay
- 3 225ms low regen delay
- 4 225ms medium regen delay
- 5 250ms low regen delay
- 6 250ms medium regen delay
- 7 275ms low regen delay
- 8 275ms medium regen delay
- 9 300ms low regen delay
- 10 300ms medium regen delay
- 11 325ms low regen delay
- 12 325ms medium regen delay
- 13 350ms low regen delay
- 14 350ms medium regen delay
- 15 375ms low regen delay
- 16 375ms medium regen delay

N LONG DELAYS

- 1 390ms low regen delay
- 2 390ms medium regen delay
- 3 400ms low regen delay
- 4 400ms medium regen delay
- 5 410ms low regen delay
- 6 410ms medium regen delay
- 7 420ms low regen delay
- 8 420ms medium regen delay
- 9 430ms low regen delay
- 10 430ms medium regen delay
- 11 450ms low regen delay
- 12 450ms medium regen delay
- 13 475ms low regen delay
- 14 475ms medium regen delay
- 15 500ms low regen delay
- 16 500ms medium regen delay

O DELAYS & CHORUS

- 1 50ms doubling delay + slow chorus
- 2 80ms slap delay + medium chorus
- 3 100ms slap delay + medium chorus
- 4 150ms regen delay + slow chorus
- 5 175ms regen delay + medium chorus
- 6 200ms regen delay + slow chorus
- 7 225ms regen delay + medium chorus
- 8 250ms regen delay + slow chorus
- 9 275ms regen delay + medium chorus
- 10 300ms regen delay + slow chorus
- 11 325ms regen delay + medium chorus
- 12 350ms regen delay + slow chorus
- 13 370ms regen delay + medium chorus
- 14 380ms regen delay + slow chorus
- 15 390ms regen delay + medium chorus
- 16 400ms regen delay + slow chorus

P SPECIAL EFFECTS

- 1 Pitch Shift octave down
- 2 Pitch Shift octave up
- 3 Pitch Shift major 3rd up
- 4 Pitch Shift major 5th down
- 5 Dual Pitch Shift major 3rd and 5th up
- 6 Dual Pitch Shift octave up and octave down
- 7 Detune Flanger
- 8 Slow Flanger w/ medium regen
- 9 Slow Flanger w/ high regen
- 10 Medium Flanger w/ medium regen
- 11 Medium Flanger w/ high regen
- 12 250ms high regen delay
- 13 500ms medium regen delay
- 14 500ms high regen delay
- 15 Slow Flanger + Pitch Shift octave down
- 16 Slow Flanger + Pitch Shift octave up

255 PRESET 16 Bit DIGITAL EFFECTS PROCESSOR

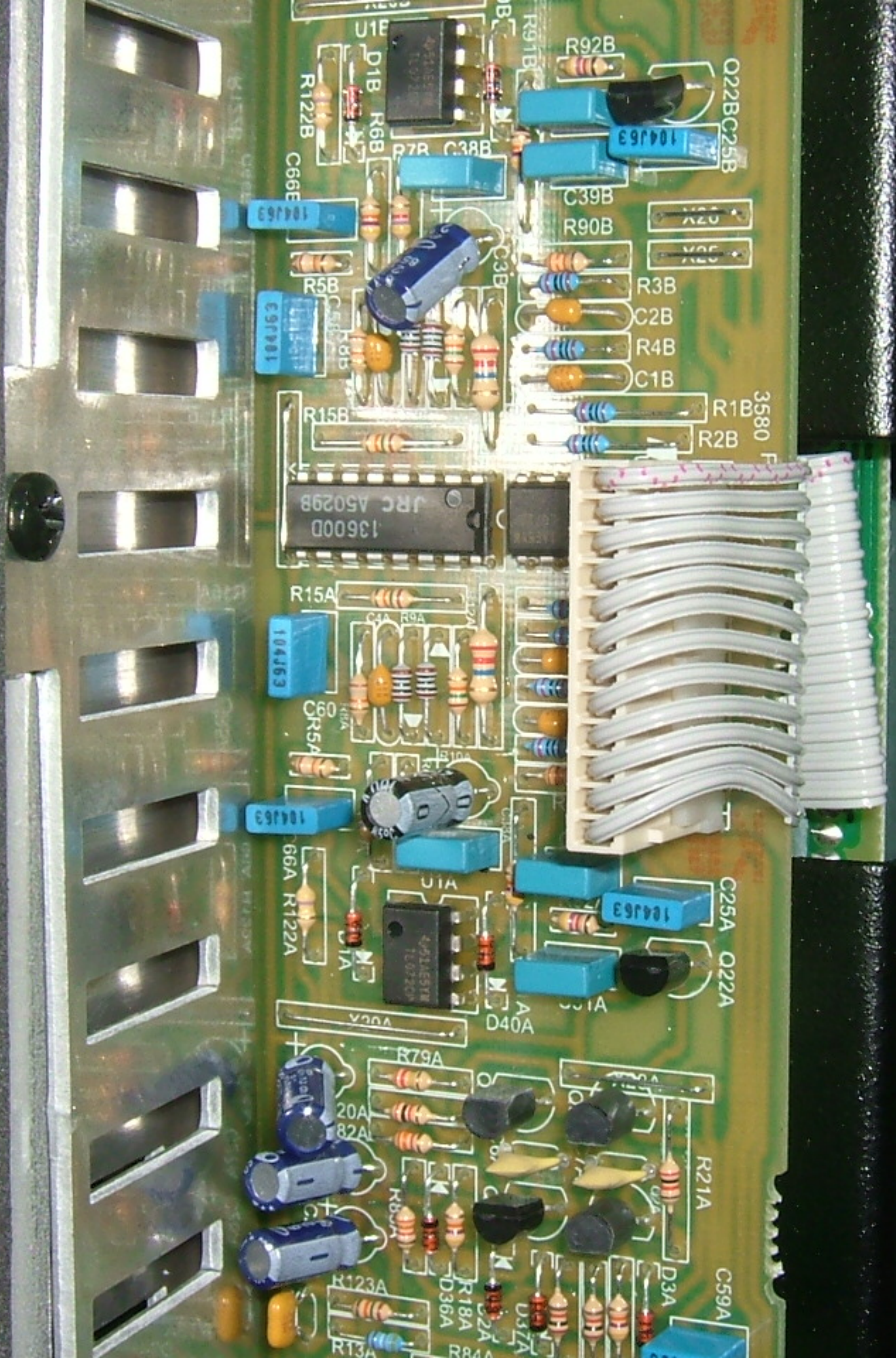

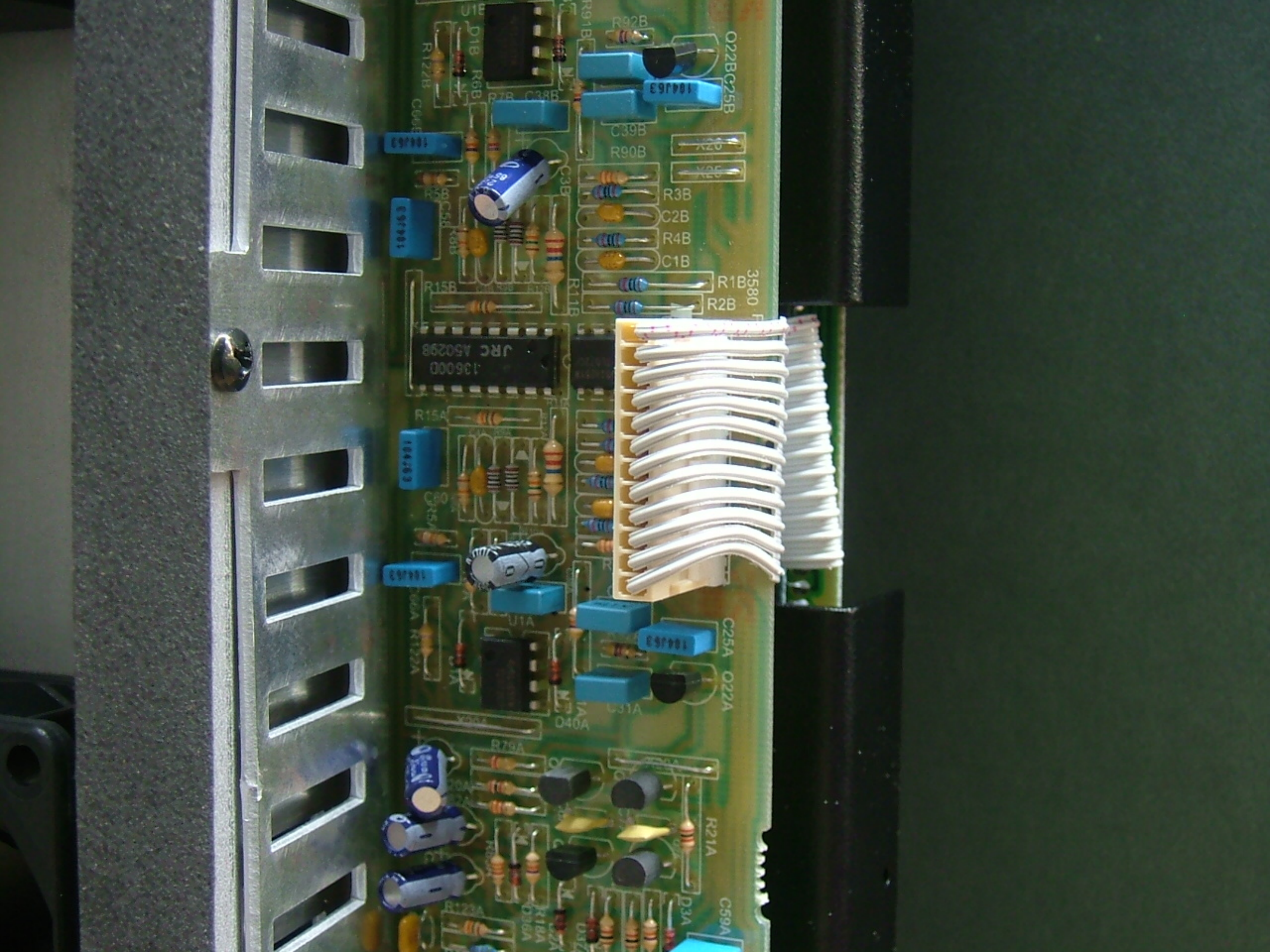

O22BG25B

E91P01

R92B

R91B

C39B

R90B

X20

X25

R3B

C2B

R4B

C1B

3580

R1B

R2B

JRC A50298
136000

R15B

104J53

C38B

D40A

E91P01

R122A

C25A

E91P01

O22A

C31A

R79A

R21A

C59A

D3A

D37A

R18A

D36A

R123A

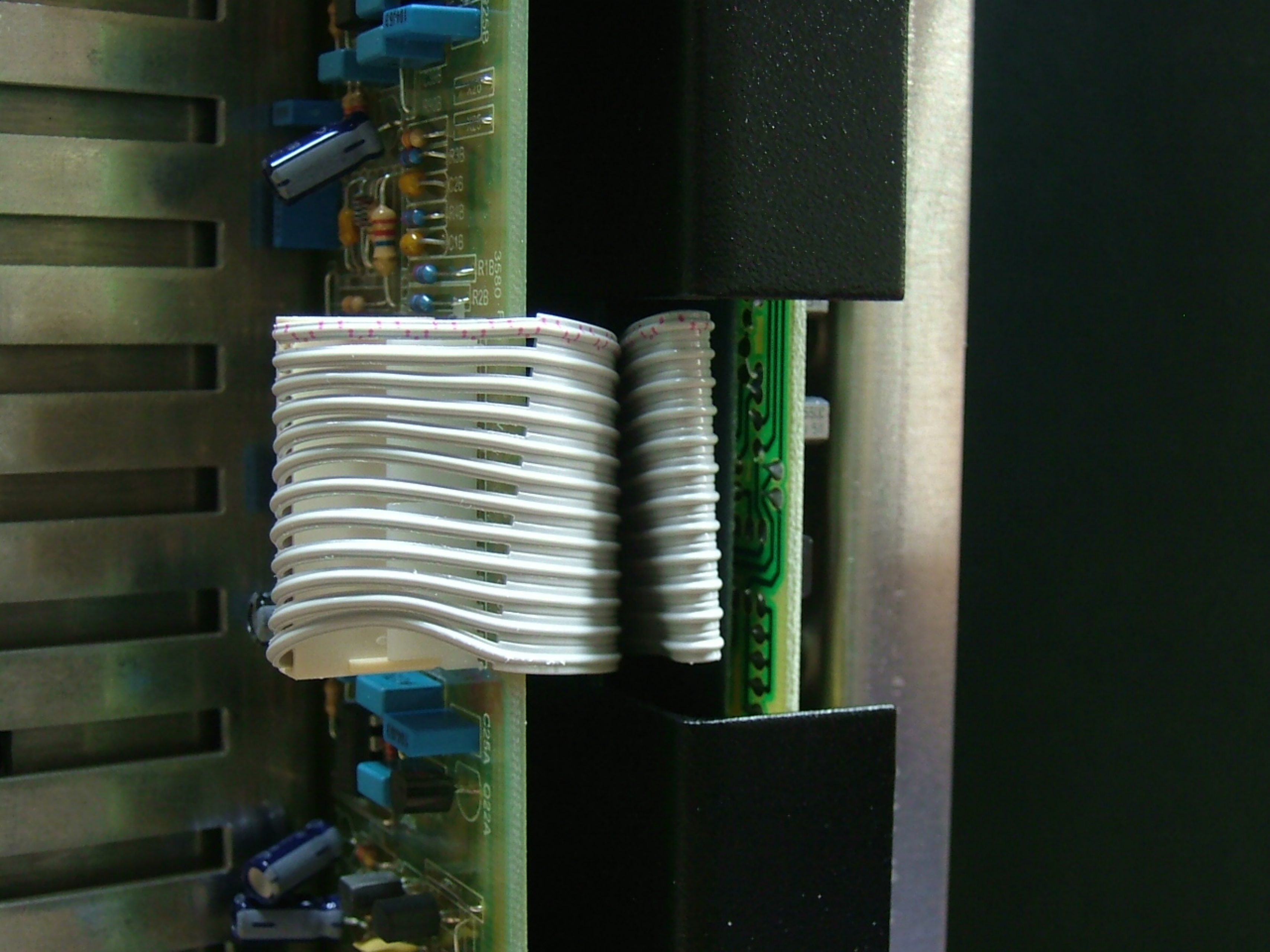

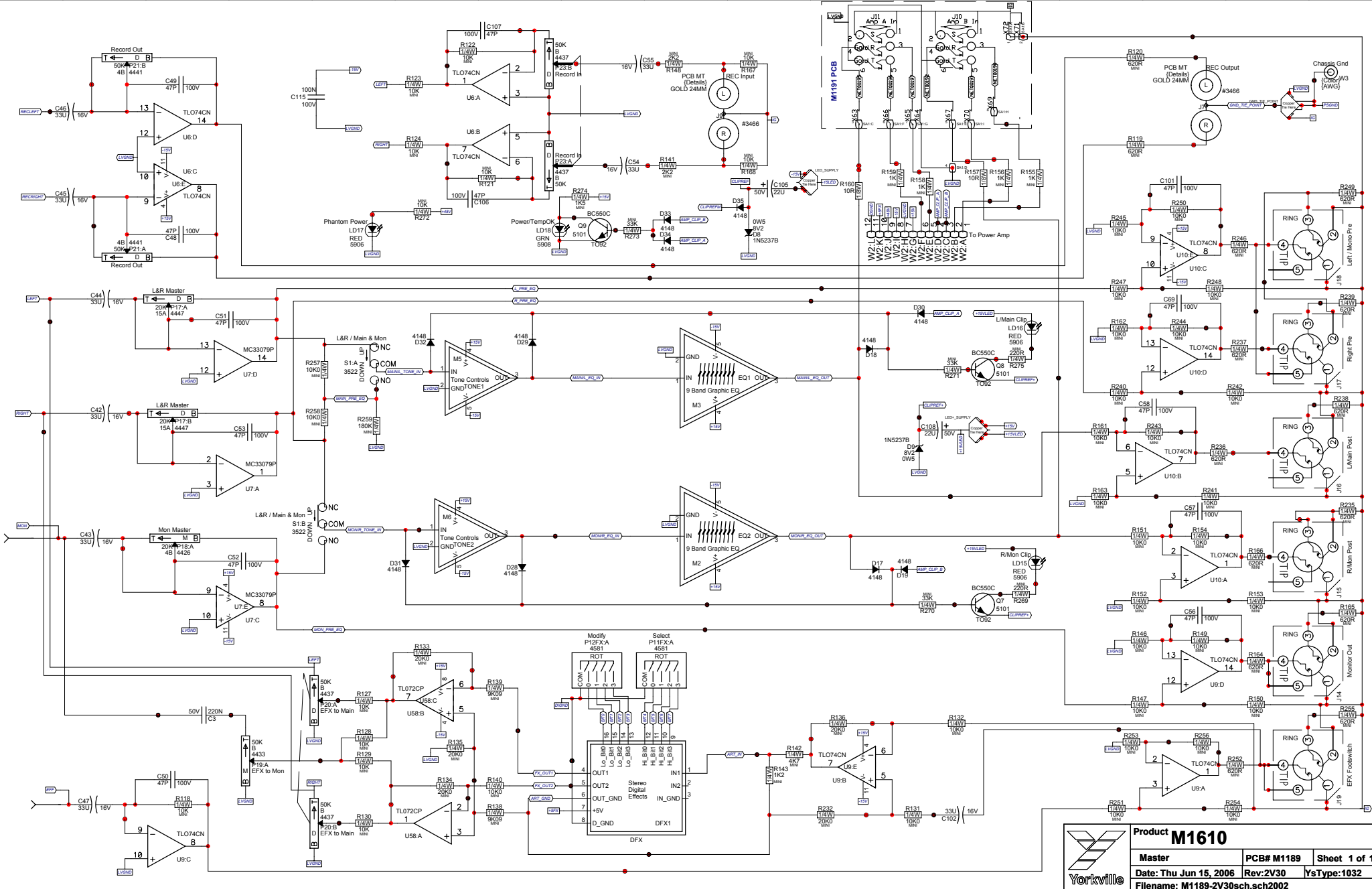

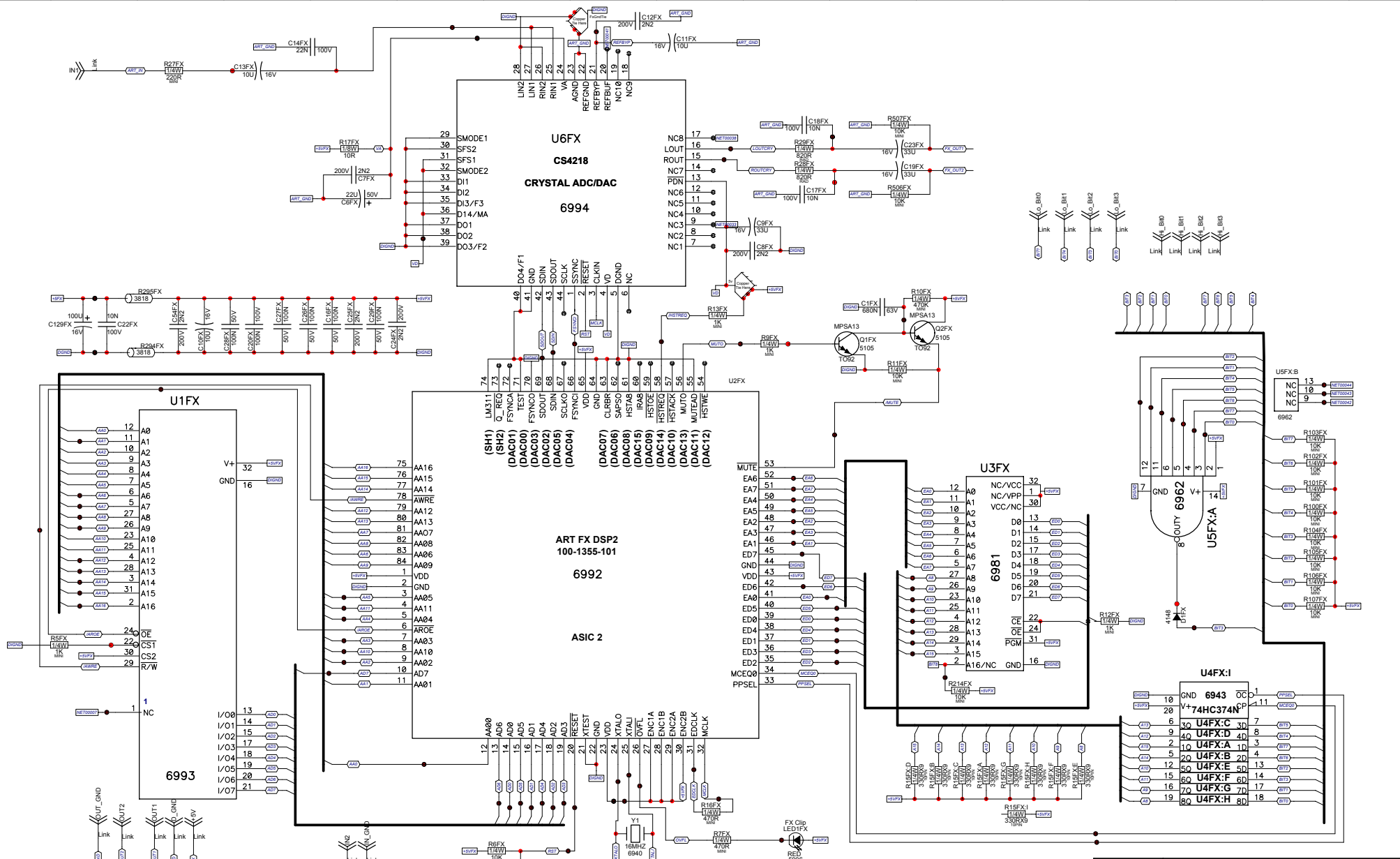

Only Channel 1 is shown,
Channels 1 - 4 employ the
same circuit.

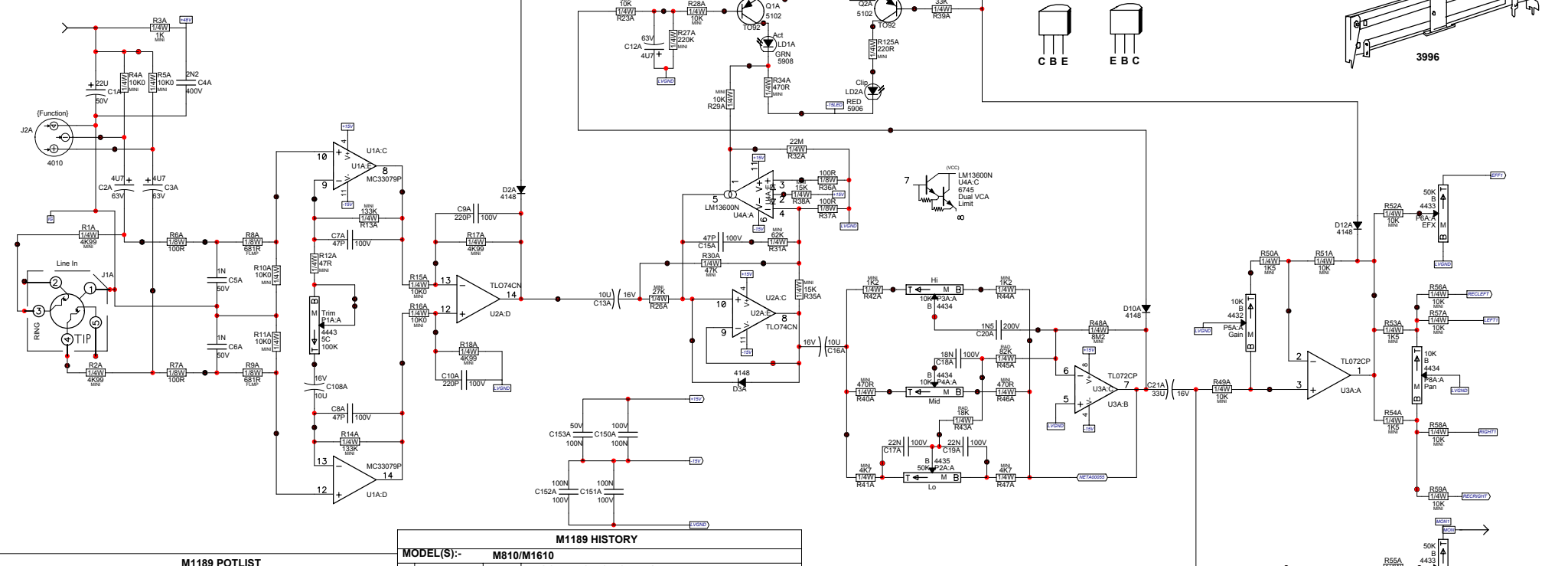

M1189 POTLIST			
M1610			
MODEL(S):-	FUNCTION	PART#	NOB (NEW)
P25-34 L&R	Graphic EQ	3988	N/A
P1A,1B,1C,1D,1E,1F	Trim	4443	9915 P32
P9G,9H	Mon Send	4443	9917 P32
P6A,5B,5C,5D,5E,5F	Level	4432	9920 P32
P15G,15H,6A,6B,6C,6D,6E,6F	FX Send	4433	9918 P32
P7A,7B,7C,7D,7E,7F	Mon Send	4433	9917 P32
P3A-F,4A-F	Hi, Mid	4434	9916 P32
P16G,16H, 8A-F	Bal, Pan	4434	9919 P32
P2A,2B,2C,2D,2E,2F	Lo	4435	9916 P32
P35,36,37,38	Master Treble, Bass	4435	9916 P32
P17,20	Master, FX2 Main	4437	9920 P34
P21,23	Rec Out	4437	9920 P34
P13G,13H,14G,14H	Stereo Hi, Mid	4438	9916 P34
P12G,12H	Stereo Lo	4439	9916 P34
P11FX,12FX	FX Select, Modify	4581	8398 P23
P23	Tape/CD	4437	9915 P34
P18,19	Monitor, FX2 Mon	4433	9917 P34
R	P	K	P32
R	F	K	N
R	F	K	N
R	F	K	N
R	F	K	N
R	F	K	N
R	F	K	N
R	F	K	N
R	F	K	N

M1189 HISTORY			
MODEL(S):-	M810/M1610	DATE	VER# DESCRIPTION OF CHANGE
		31 Dec 2003	v1.00p Moved D3 anode to cathode of LD1
		2 Feb 2004	1.00 Change break mute flash rate
		17 Feb 2004	1.01 Move C7a-f, R13a-f to make room for AA series xlr.
			V Change hole sizes for AA series xlr.
			V Changed U1FX SRAM to 4010 AA series
		24 Feb 2004	1.02 Changed 3925 XLRs to 4010 AA series
		7-APR-2004	2.00 PC#6875 Moved C15(A,C,E,F) to avoid hitting ICs
			V Removed routing from board - slots done on drill now
		15-APR-2004	2.00 PC#6677 Chg X41 to C3(220n 50V), set gerber
			V so TIE4 gets output properly
		11 D	V PC#6679 Chg. C21(A,B,C,D,E,F) from 470nF to 33uF
		12 D	V PC#6686 MOVED C23FX AWAY FROM SPACER
		6-MAY-2004	2.00
		Aug 4, 2004	2.00 Fixed silk screen on U6FX and U2FX
		1 AUG-16-2004	2.10 PC#6718 CHANGE R140 TO 10K0 (6116),
			V R138&R139 TO 9K09 (6112)
		NOV-23-2004	V PC#6771:#3571->#3507 SKT FOR #6993 SRAM (GT)
		4 JAN-05-2005	1.00 GT:PC#6792:P17 FROM 50KB #4441 TO 20KA #4447
		21 Apr 2005	2.11 Updated 3921 jacks for clinch.
		4 Aug 2005	2.20 AH, PC#6816, ADD A HOLE FOR FEEDING GROUND WIRE
			V P
			V N
		14 JUN 2006	2.30 AH, PC#7091, UPDTAE #5322 CHANGE DRILL SIZE TO
			V #6989, STRENGTHEN RCA JACK SECTION BREAKAW
			V #4581 UPDATED, PROPER DRILLING ORDER
			V N
			V N
			V N
			V N
			V N
			V N
			V N

M1189 DRILL HISTORY			
MODEL(S):-	M810/M1610	DATE	VER# DESCRIPTION OF CHANGE
		24-FEB-2004	V01 N
		21-APR-2005	V02 N
		4-AUG-2005	V03 PC#6818, ADDING A HOLE FOR FEEDING GREEN GND
			V N
			V N
			V N
			V N
			V N
M1189 PENDING CHANGES			
MODEL(S):-	M1610	#	PC# PENDING CHANGE
		1	PC X
		2	PC X
		3	PC X
		4	PC X
		5	PC X
		6	PC X



Product M1610		
Mono Ch1	PCB# M1189	Sheet 3 of 16
Date: Thu Jun 15, 2006	Rev:2V30	YsType:1032
Filename: M1189-2V30sch.sch2002		

Only Channel 5 is shown.
Channels 5 & 6 employ
the same circuit.

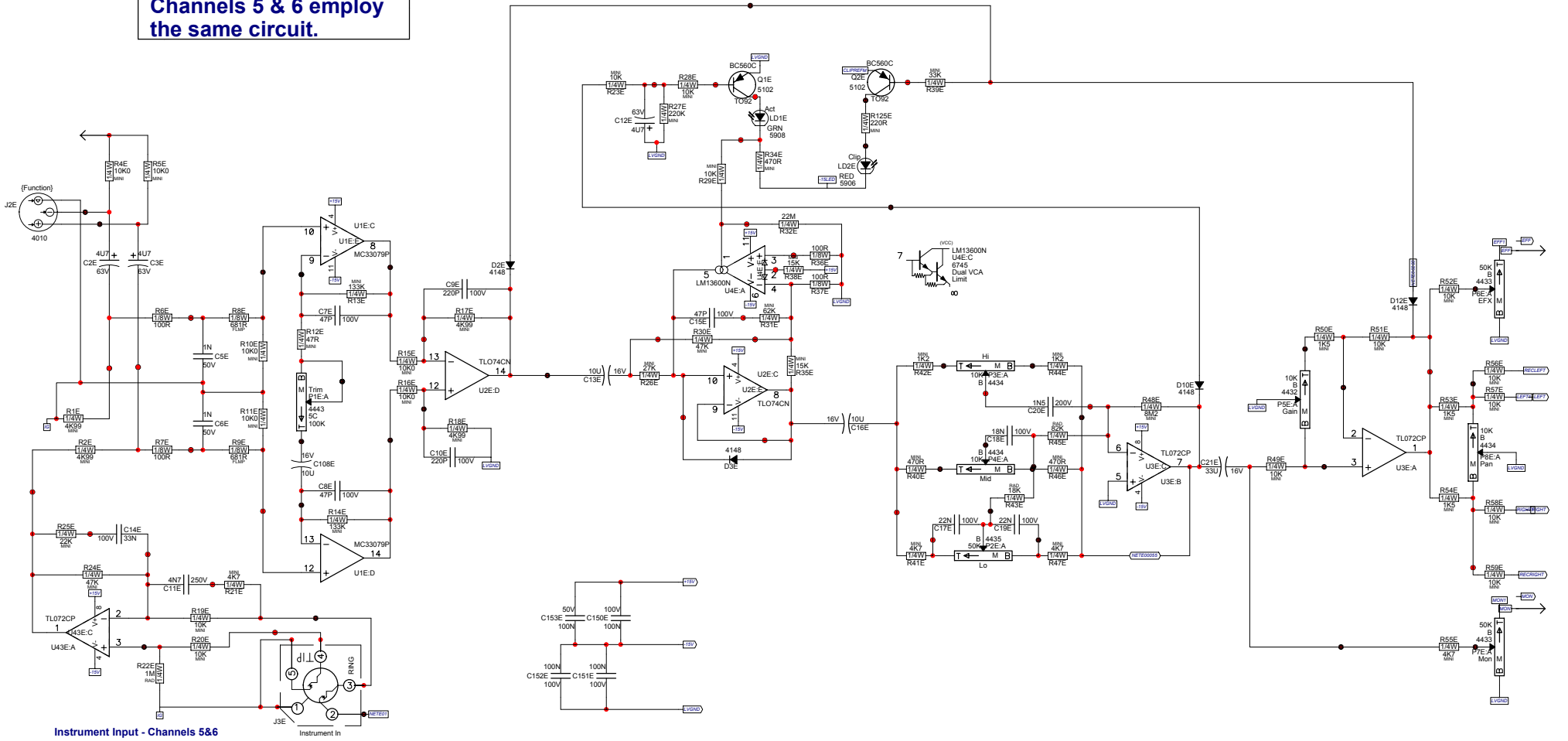

Instrument Input - Channels 5&6

Only channels 7&8 are shown.
Channels 9&10 employ
the same circuit.

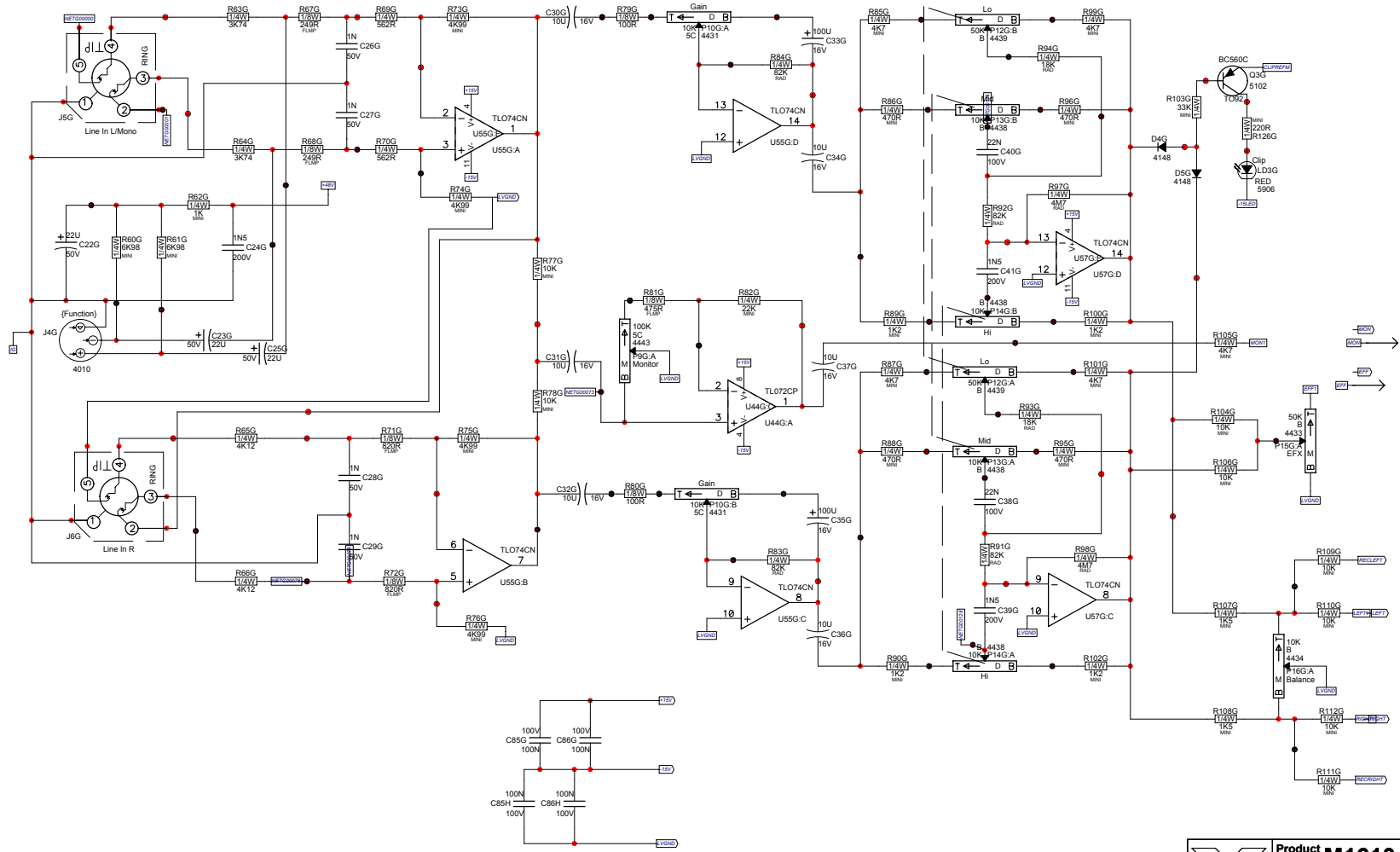

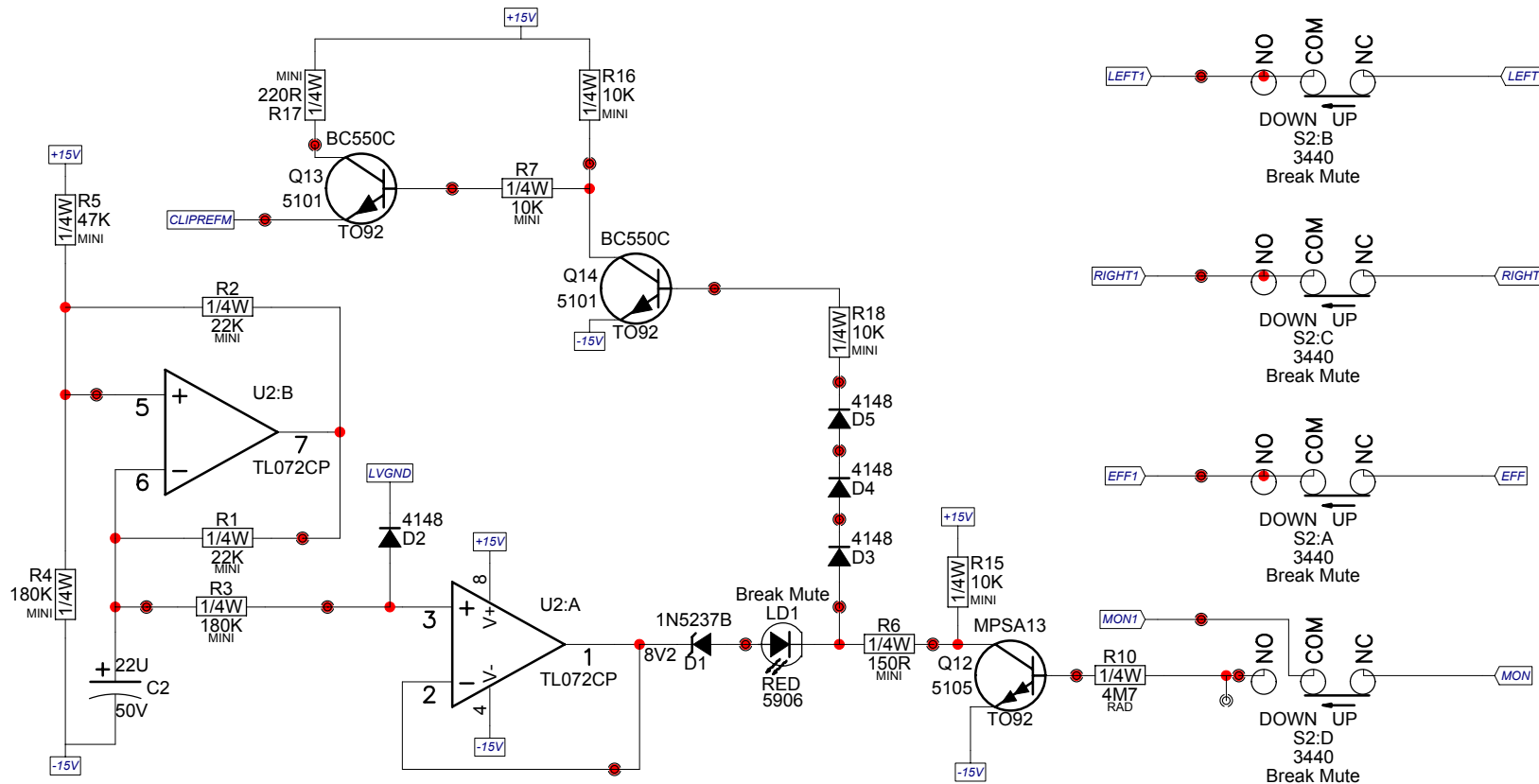

Product **M1610**

BreakMute

PCB# M1189

Sheet 11 of 16

Date: Thu Jun 15, 2006

Rev:2V30

YsType:1032

Filename: M1189-2V30sch.sch2002

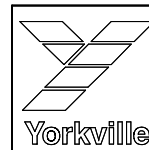
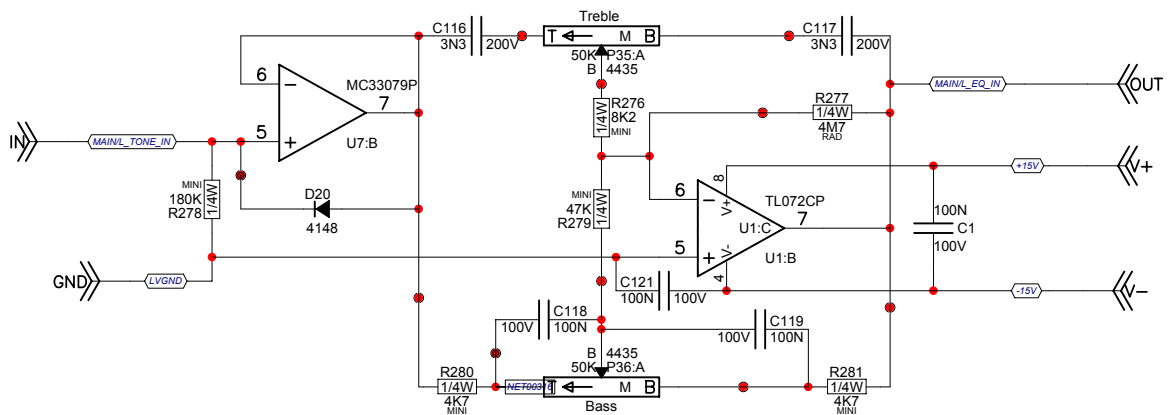

Product **M1610**

TONE1 PCB# M1189 Sheet 13 of 16

Date: Thu Jun 15, 2006 Rev: 2V30 YsType: 1032

Filename: M1189-2V30sch.sch2002

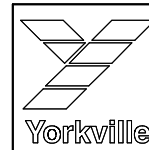
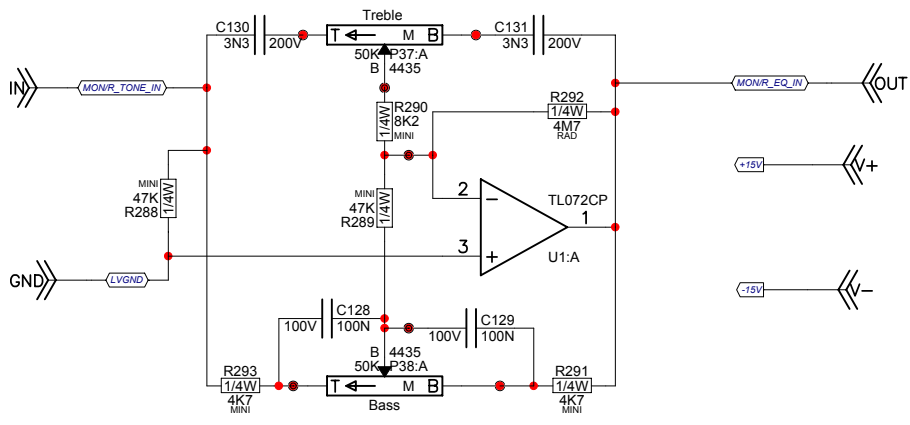

Product M1610		
TONE2	PCB# M1189	Sheet 14 of 16
Date: Thu Jun 15, 2006	Rev:2V30	YsType:1032
Filename: M1189-2V30sch.sch2002		

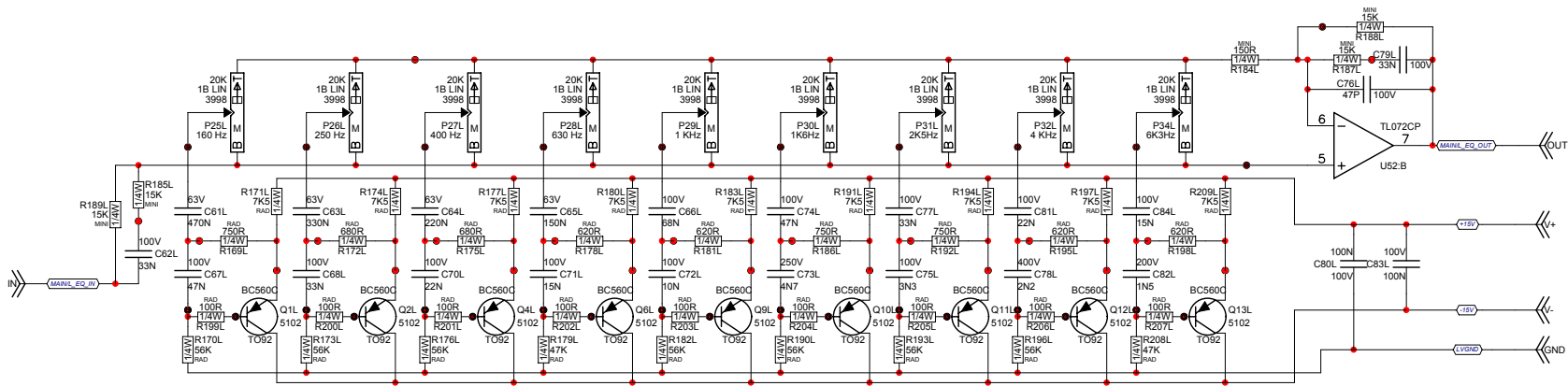

Product M1610		
EQ1	PCB# M1189	Sheet 15 of 16
Date: Thu Jun 15, 2006	Rev: 2V30	YsType: 1032
Filename: M1189-2V30sch.sch2002		

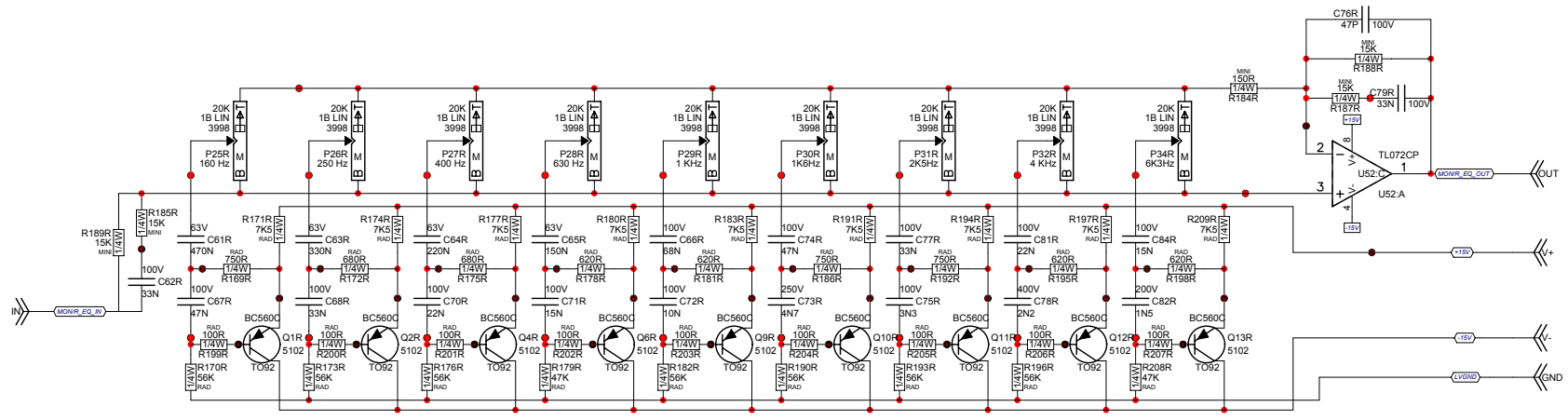

Product M1610		
EQ2	PCB# M1189	Sheet 16 of 16
Date: Thu Jun 15, 2006	Rev: 2V30	YsType: 1032
Filename: M1189-2V30sch.sch2002		

M1189
M1610
2V30

0EV5 8B11M

SF01 - 09V1T 2V
YS Type -1032

Blank Size - 17900 x 10750
05V0T x 006V1 - 0512 XnsB12

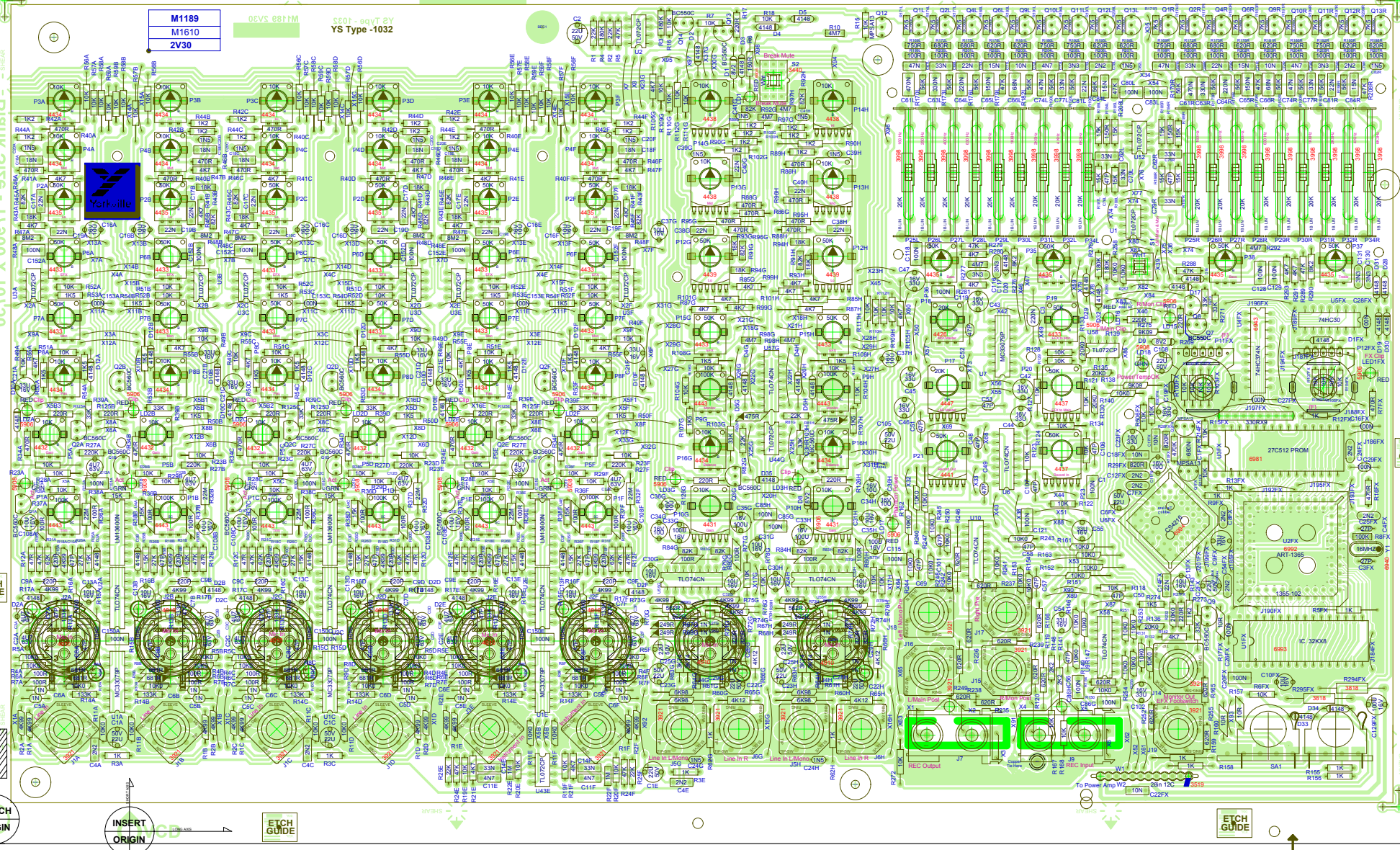

ETCH GUIDE

ETCH GUIDE

CLINCH ORIGIN

INSERT ORIGIN

ETCH GUIDE

ETCH GUIDE

SEE LAYOUT DOCUMENTATION



SEE LAYOUT DIAGRAM

**PRODUCTION NOTES**

1. Stuff 1 M1191 pcb here.
2. U3FX & U1FX - Mount 28 pin IC sockets to the RIGHT side of the 32 holes.

M1189 HISTORY				M1189 POTLIST					
MODEL(S):- M1610				MODEL(S):- M1610					
#	DATE	VER#	DESCRIPTION OF CHANGE	REF	FUNCTION	PART#	NOB	(NEW)	
1	31 Dec, 2003	v1.00	Moved D3 anode to cathode of LD1	P25-34 L&R	Graphic EQ	3998	N/A	N	
2	2 Feb, 2004	1.00	Change break mute flash rate	P1A,1B,1C,1D,1E,1F	Trim	4443	9915	N	
3	17 Feb, 2004	1.01	Move C7a-f, R13a-f to make room for AA series xlr.	P9G,9H	Mon Send	4443	9917	N	
4	.	.	Change hole sizes for AA series xlr.	P5A,5B,5C,5D,5E,5F	Level	4432	9920	N	
5	.	.	Changed U1FX SRAM to 32kX8	P15G,15H,6A,6B,6C,6D,6E,6F	FX Send	4433	9918	N	
6	24 Feb, 2004	1.02	Changed 3925 XLRs to 4010 AA series	P7A,7B,7C,7D,7E,7F	Mon Send	4433	9917	N	
7	7-APR-2004	2.00	PC#6675 Moved C150(A,C,E) to avoid hitting ICs	P3A-F,4A-F	Hi, Mid	4434	9916	N	
8	.	.	Removed routing from board - slots done on drill now	P16G,16H, 8A-F	Bal, Pan	4434	9919	N	
9	15-APR-2004	2.00	PC#6677 Chg X41 to C3(220n 50V), set gerber so TIE4 gets output properly	P2A,2B,2C,2D,2E,2F	Lo	4435	9916	N	
10	.	.	PC#6679 Chg. C21(A,B,C,D,E,F) from 470nF to 33uF	P35,36,37,38	Master Treble, Bass	4435	9916	N	
11	6-MAY-2004	2.00	PC#6686 MOVED C23FX AWAY FROM SPACER	P17,20	Master, Rec Out	4441	9920	N	
12	Aug 4, 2004	2.00	Fixed silk screen on U6FX and U2FX	P21	FX2 Main	4437	9920	N	
13	AUG-16-2004	2.10	PC#6718 CHANGE R140 TO 10K0 (6116), R138&R139 TO 9K09 (6112)	P13G,13H,14G,14H	Stereo Hi, Mid	4438	9916	N	
1	D	V	PC#6771:#3571->#3507 SKT FOR #6993 SRAM (GT)	P12G,12H	Stereo Lo	4439	9916	N	
2	NOV-23-2004	.	GT:PC#6792:P17 FROM 50KB #4441 TO 20KA #4447	P11FX,12FX	FX Select, Modify	4581	8398	N	
3	JAN-05-2005	.	Updated 3921 jacks for clinch.	P23	Tape/CD	4437	9915	N	
4	21 Apr, 2005	2.11	AH, PC#6816, ADD A HOLE FOR FEEDING GREEN GROUND WIRE.	P18	Monitor	4441	9917	N	
5	4 Aug 2005	2.20	AH, PC#7091, UPDTAE #5322 CHANGE DRILL SIZE TO #0	P19	FX2 Mon	4433	9917	N	
6	14 JUN 2006	2.30	PC#6989, STRENGTHEN RCA JACK SECTION BREAKAWAY #4581 UPDATED, PROPER DRILLING ORDER	R	F	P	K	N	
7	.	.		R	F	P	K	N	
8	.	.		R	F	P	K	N	
9	.	.		R	F	P	K	N	
10	D	V	N	R	F	P	K	N	
11	D	V	N	R	F	P	K	N	
12	D	V	N	R	F	P	K	N	
13	D	V	N	R	F	P	K	N	

M1189 DRILL HISTORY				M1189 PENDING CHANGES	
MODEL(S):- M810/M1610				MODEL(S):- M1610	
#	DATE	VER#	DESCRIPTION OF CHANGE	#	PC#
1	24-FEB-2004	V01	N	1	PC
2	21-APR-2005	V02	N	2	PC
3	4-AUG-2005	V03	N	3	PC
4	D	V	N	4	PC
5	D	V	N	5	PC
6	D	V	N	6	PC

*PLACE IMPLEMENTED CHANGES INTO BOARD HISTORY

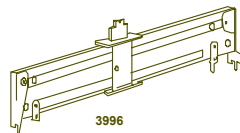

3996



"STYLE_P23"

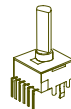

"STYLE_P34"

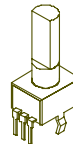

"STYLE_P32"



MPSA13, 56

E B C



BC550, 560

C B E

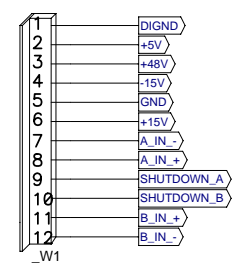
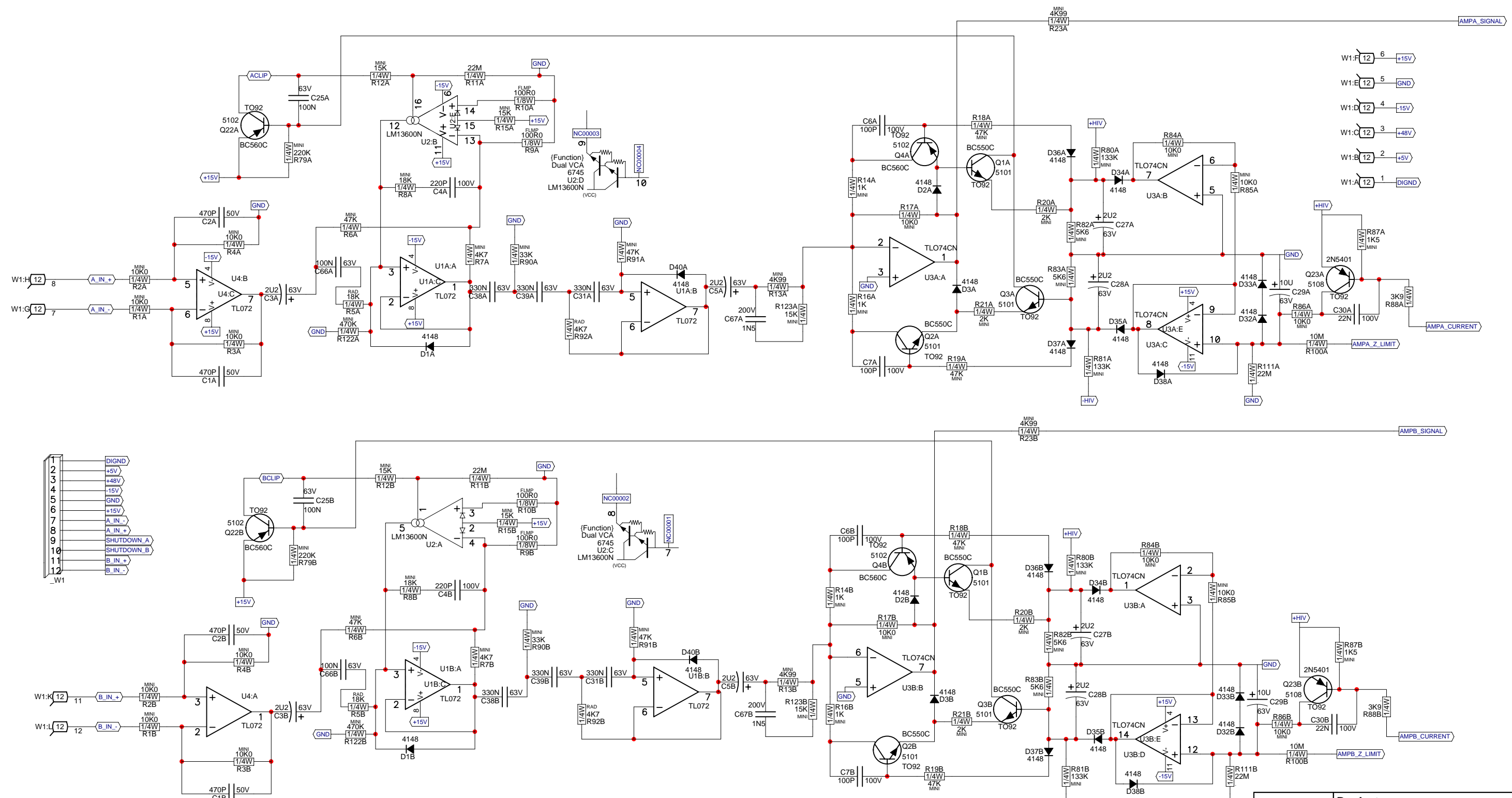

			Product M1610		
			Ampln	PCB# M1190	Sheet 1 of 4
Date: Thu Feb 04, 2010			Rev: V11.0		YsType: .
Filename: M1190V1100sch.sch2002					

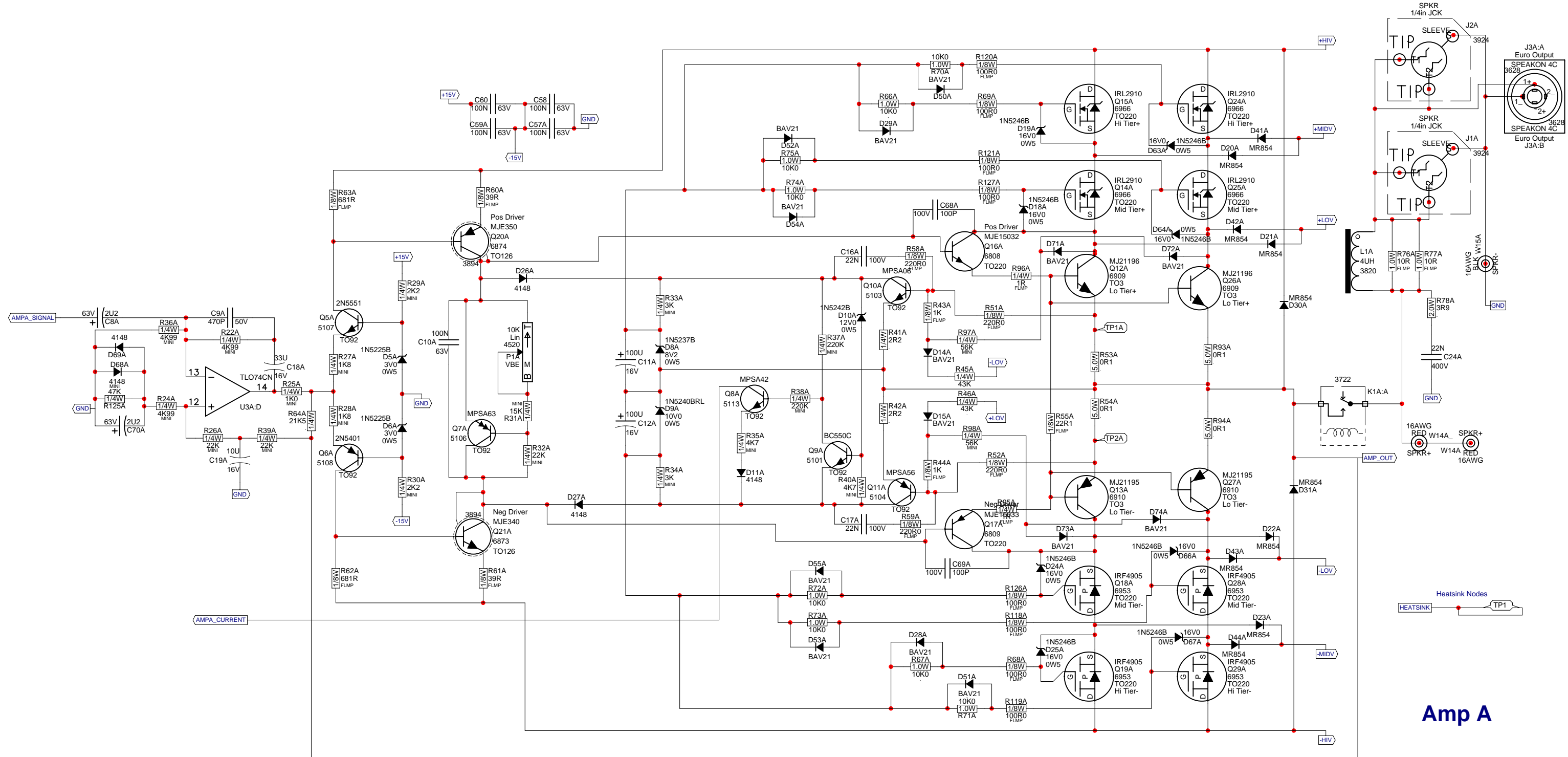

Amp A

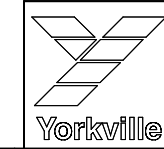

Product M1610		
Channel A	PCB# M1190	Sheet 2 of 4
Date: Thu Feb 04, 2010	Rev:V11.0	YsType:..
Filename: M1190V1100sch.sch2002		

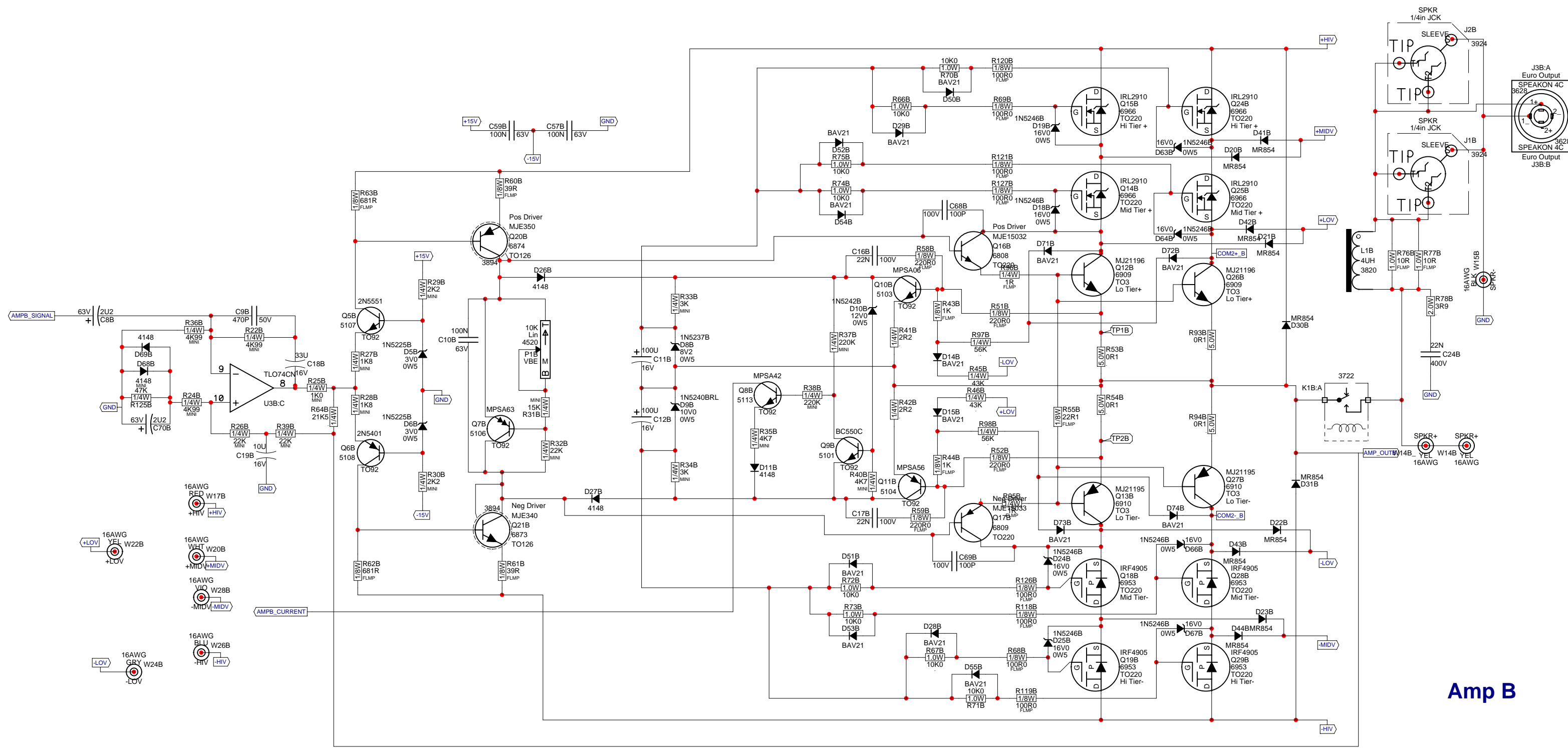

Amp B

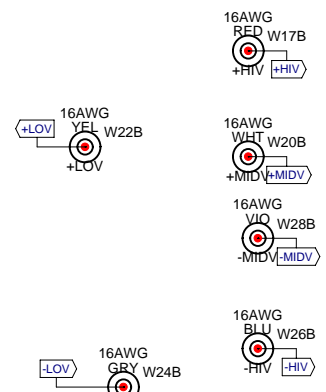

Product M1610	
Channel B	PCB# M1190
Date: Thu Feb 04, 2010	Rev:V11.0
YsType:..	Sheet 3 of 4
Filename: M1190V1100sch.sch2002	

M1190.PCB_DATABASE_HISTORY				#	DATE	VER#	DESCRIPTION OF CHANGE
MODEL(S):- M1610				24			R79A&B #6127 470K->#6127 220K
				25			ADDED D4 #5124 5V1/5W, R97&R98 #2006 1R/1W->#5124
				26			Corrected the position of some test nodes.
				27			Fixed BlankSize field
				28	Jun-15-2006	7.00	AH, PC#7021, SPACE BETWEEN R96 AND R53
				29			PC#6983, WIDEN TRACE BETWEEN C32 AND C37
				30			PC#7091, ENLARGE HOLE SIZE FOR #3522
				31	2008/04/07	v8.00	Swap c37 with c51; c51 with c36. Moved x11b & x31b to middle of HS slots. Solder updates, part updates.
				32			Changed Q8a&b from 5107 to 5113 - MPSA42
				33	2008/04/25	v8.00	PC#7590 - PS hum fix. Moved K1B away from X15B.
				34	2008/05/29	9.00	PC#7875, 7876 - Ribbon cable change - XTR screws flipped
				35	2009/11/09	10.00	PC#7942, PC#7980: Update #4xTO220-MTG
				36	03-FEB-2010		PC#7983: Change D2,D3,D4 #5124 span to .525
				37	04-FEB-2010	11.00	
				38			
				39			
				40			
				41			
				42			
				43			
				44			
				45			
				46			
				47			
				48			
				49			
				50			

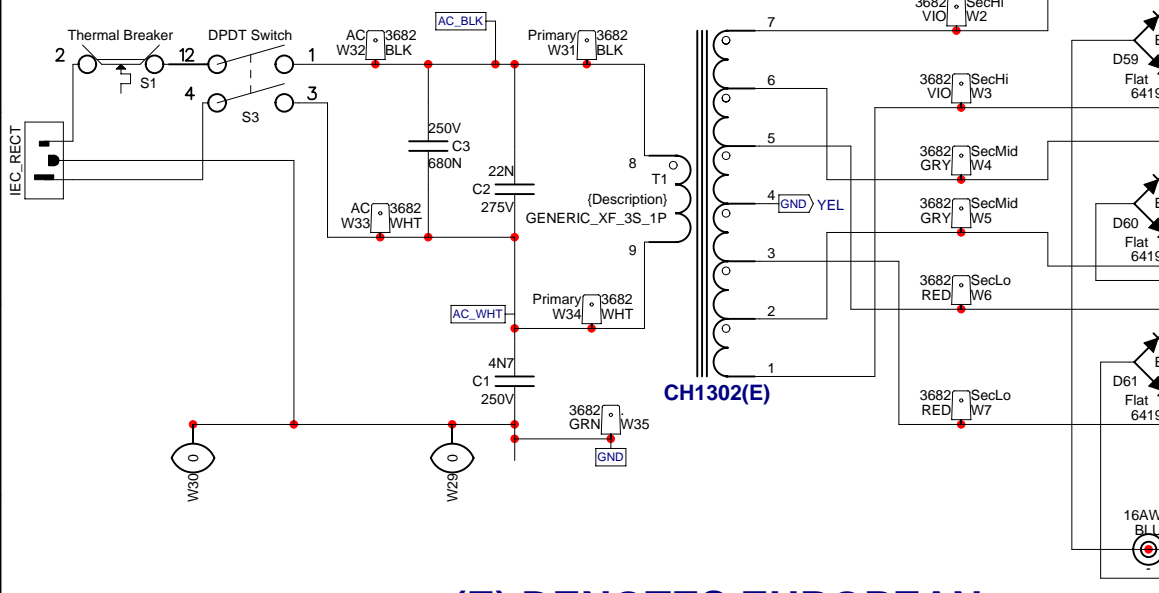
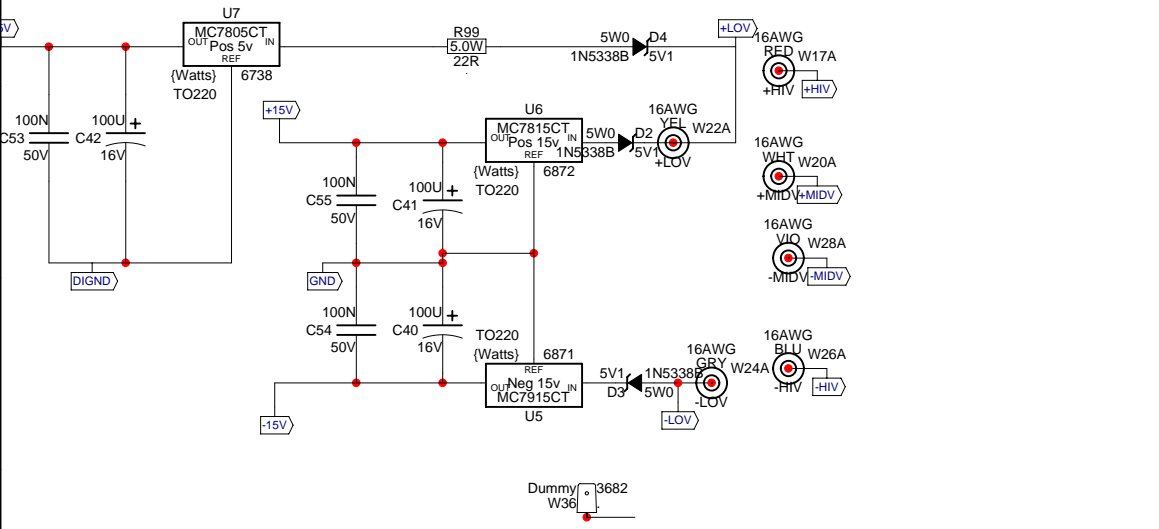
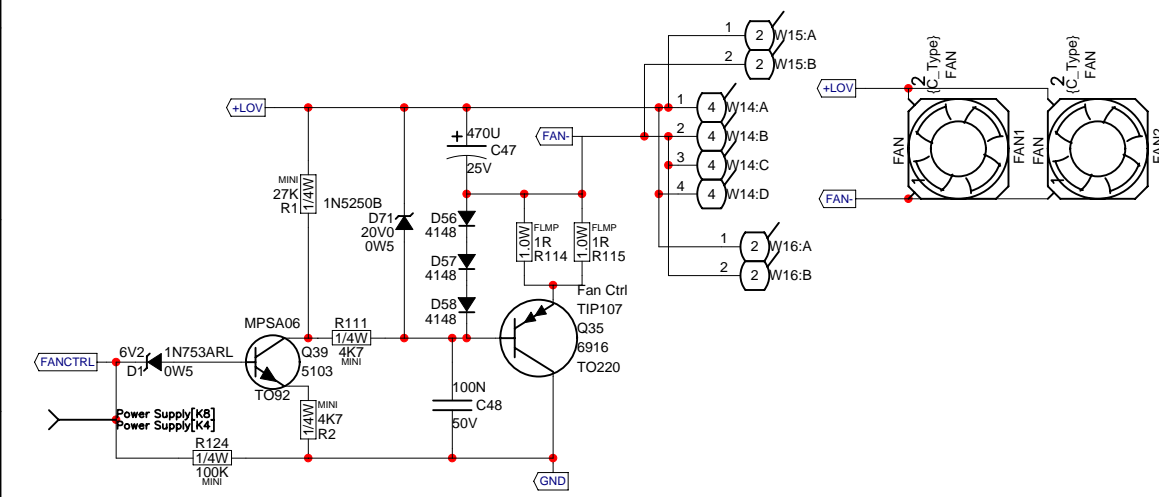

(E) DENOTES EUROPEAN

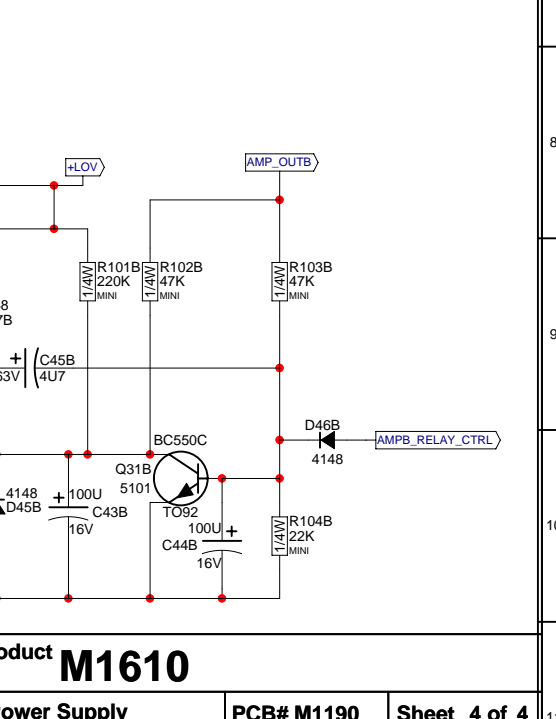
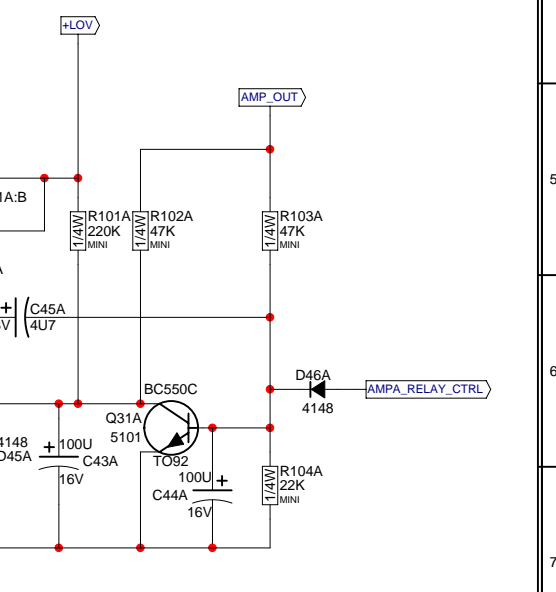
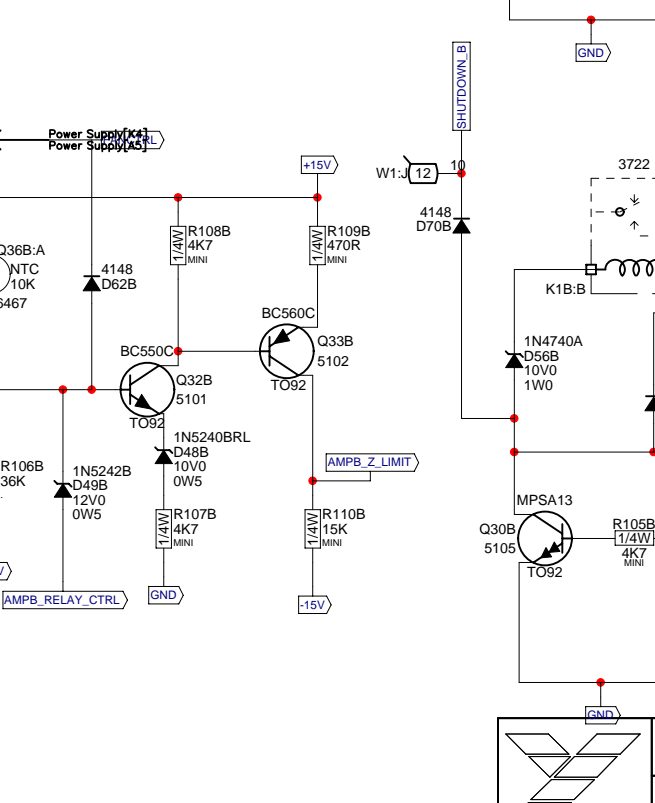
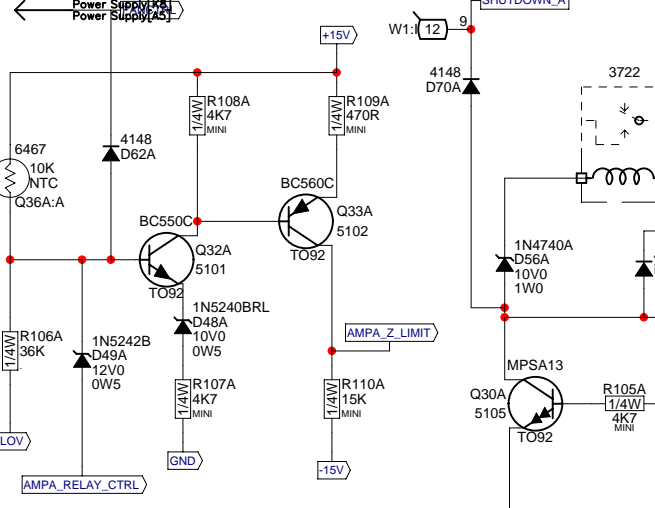
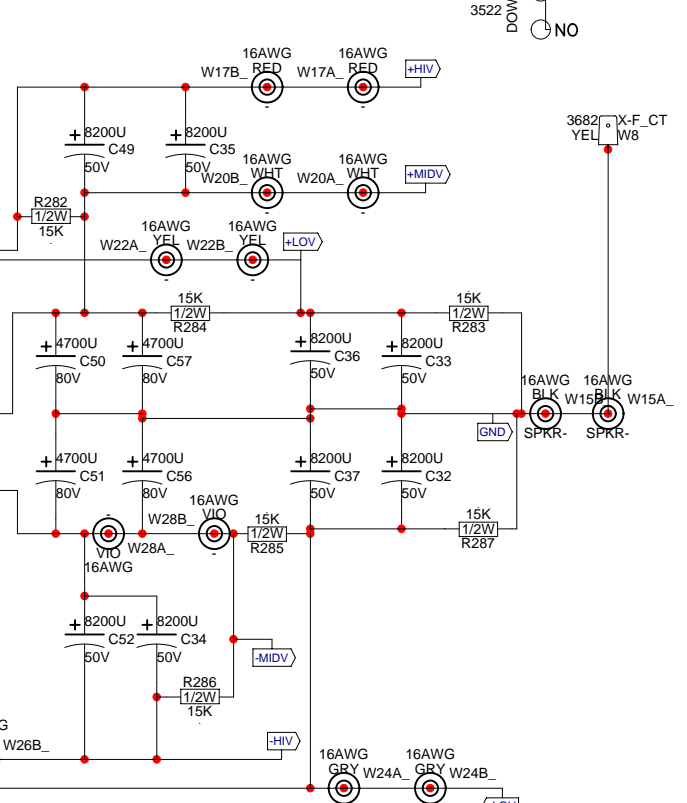
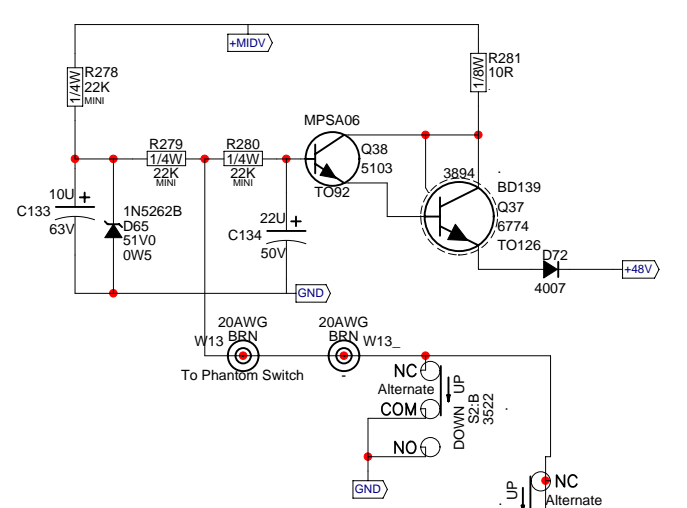

Set P1 for 8mV
between TP1 and TP2

Set P1 for 8mV
between TP1 and TP2

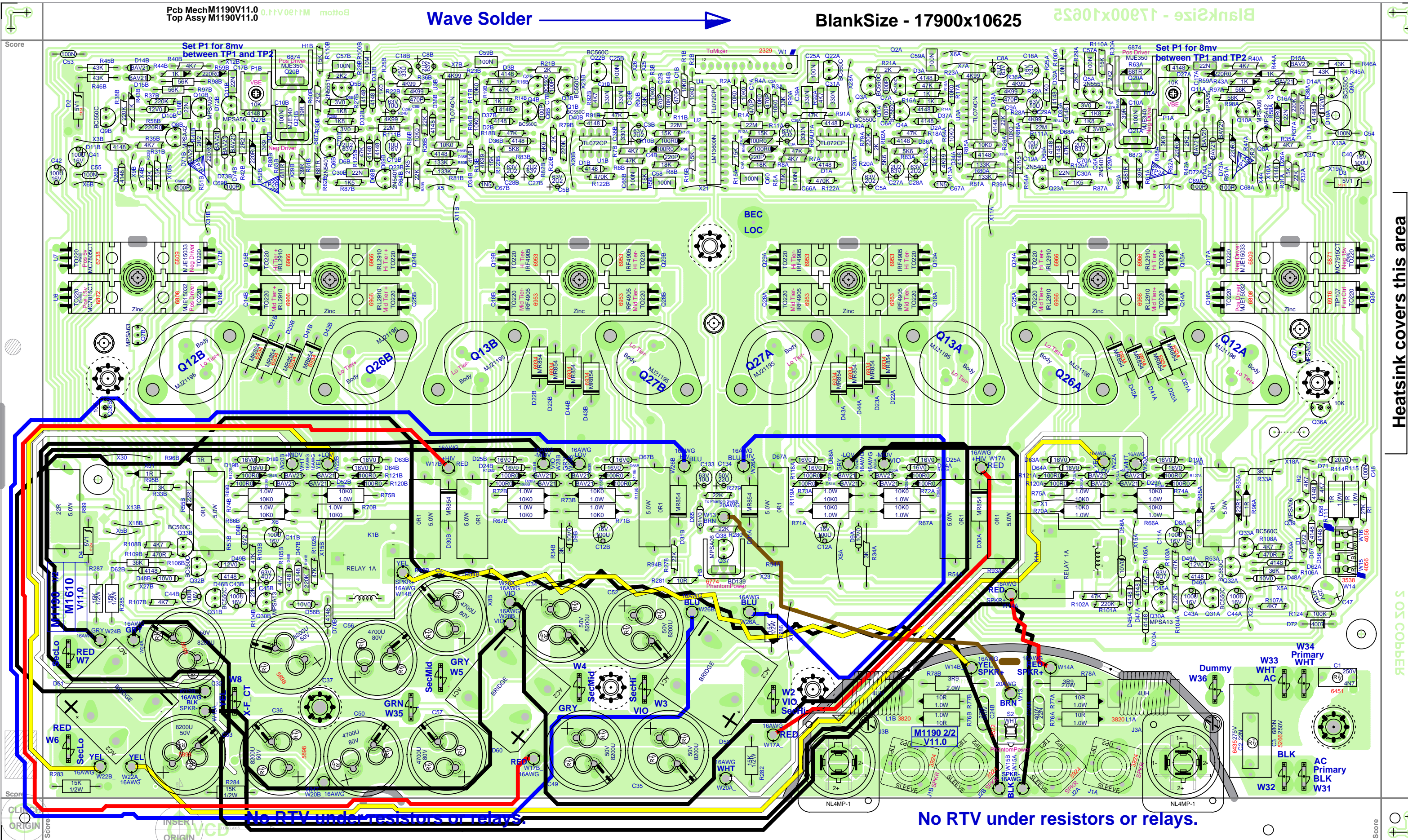

Heatsink covers this area

50% COPPER

No RTV under resistors or relays.

No RTV under resistors or relays.

SEE LAYOUT DOCUMENTATION



SEE LAYOUT DIAGRAM



M1190 PRODUCTION NOTES

1. Use three 8832 screws to align and attach the heatsinks to the board
2. When assembling heatsinks to Q20(A&B), Q21(A&B), Q37, ensure heatsinks are straight and sit flat against board. Add a very small amount of RTV between heatsink and board if necessary. This prevent heatsink from shorting other components.

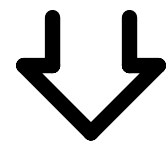
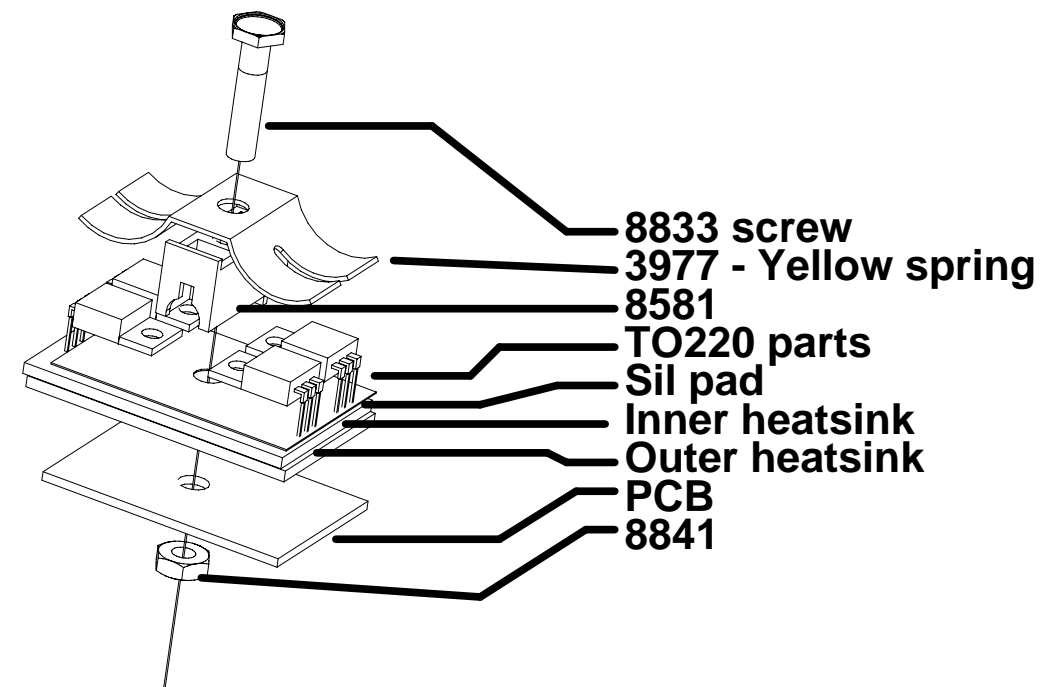
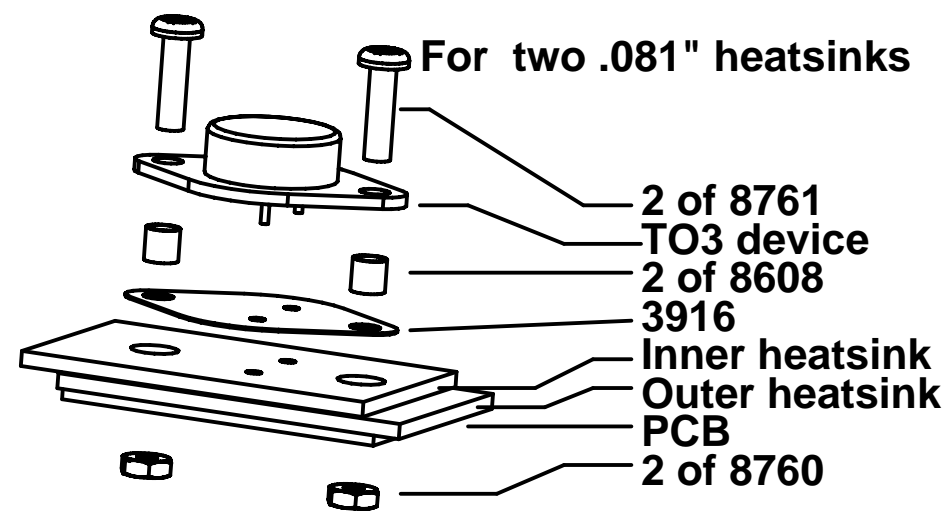

SEE LAYOUT HISTORY

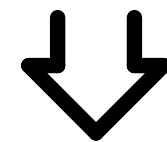



SEE PPRODUCTION NOTES



M1190.PCB_DATABASE_HISTORY				#	DATE	VER#	DESCRIPTION OF CHANGE
MODEL(S):- M1610				24	.	.	R79A&B #6127 470K->#6127 220K
				25	.	.	ADDED D4 #5124 5V1/5W, R97&R98 #2006 1R/1W->#5124
				26	.	.	Corrected the position of some test nodes.
				27	.	.	Fixed BlankSize field
				28	Jun-15-2006	7.00	AH, PC#7021, SPACE BETWEEN R96 AND R53
				29	.	.	PC#6983, WIDEN TRACE BETWEEN C32 AND C37
				30	.	.	PC#7091, ENLARGE HOLE SIZE FOR #3522
				31	2008/04/25	8.00	Swap c37 with c51; c57 with c36. Moved x11b & x31b to middle of HS slots. Solder updates, part updates.
				32	.	.	
				33	.	.	Changed Q8a&b from 5107 to 5113 - MPSA42
				34	2008/05/29	9.00	PC#7590 - PS hum fix. Moved K1B away from X15B.
				35	2009/11/09	10.00	PCs 7875, 7876 - Ribbon cable change - XTR screws flipp
				36	03-FEB-2010	.	PC7942,PC7980: Update #4xTO220-MTG GG
				37	04-FEB-2010	11.00	PC7983: Change D2,D3,D4 #5124 span to .525 GG
				38	D	V	N
				39	D	V	N
				40	D	V	N
				41	D	V	N
				42	D	V	N
				43	D	V	N
				44	D	V	N
				45	D	V	N
				46	D	V	N
				47	D	V	N
				48	D	V	N
				49	D	V	N
				50	D	V	N
#	DATE	VER#	DESCRIPTION OF CHANGE				
1	7 Jan, 2004	1.00	Rationalize wire refdes				
2	24 Feb, 2004	1.00	Add speakon jacks to output section				
3	10 Mar, 2004	1.00	Enlarge cutouts for 8841 nuts				
4	21-APR-2004	1.00	PC#6681 Modify route to let grn wire pass board near pwr cap				
5	6-MAY-2004	2.00	PC#6684 R83(A,B)->5K6,R5(A,B)6K8->18K, D16&D17(A,B) 4148->BAT85,R47&R48(A,B)22R1->100R0				
6			ADDED D71, D72				
7							
8	DEC-14-2004	3.00	GT:PC#6787: Fixed AC clearance, and W2&W3 tab label				
9	FEB-07-2005	4.00	PC#6809 Remove D17,D16,D12,D13, R47,R48,R49,R50,C14				
10	D	V	C15 (All A/B) R45,R46 A/B 36K->43K, D10 16V->12V				
11	D	V	D9 A/B 14V->10V0, D8 A/B 12V->8V2. ADD R95 A/B				
12	D	V	ADD R96 A/B, R97 A/B, R98 A/B, D71 A/B, D72 A/B				
13	D	V	D73 A/B, D74 A/B, X1 ,X2 ,X3 ,X4 X5 AND X6				
14	MAR-30-2005	5.00	RECREATED MASK LAYER TO FIX TESTPADS				
15	MAR-13-2005	5.10	CHANGE IRF3205 #6954 TO IRL2910 #6966				
16	.	.	PLACE MICA UNDER MIDDLE TIER MOSFETS				
17	21 Apr, 2005	5.11	Force update parts to fix pad orientation				
18	JUN-08-2005	6.00	PC#6919:GT:MOVED R95B AVOID HEATSINK COLLISION				
19	.	.	XFORMER -> CH1302/E, ADDED 2x#4599,SWAPPED W8 &				
20	.	.	W35,R106A&B #6122 33K->#4868 36K, D56A&B #6440				
21	.	.	4V7/0.5W->#6484 10V/1W, C32&C33 #5903 12000UF/35V ->				
22	.	.	#5898 8200UF/50V, C36&C37 #5896 4700UF/80V->#5898				
23	.	.	C25A&B #5224 47N/100V->#5212 100N/63V				

M1190 Drill History				M1190 PENDING CHANGES		
MODEL(S):- M1610				MODEL(S):- M1610		
#	DATE	VER#	DESCRIPTION OF CHANGE	#	PC#	PENDING CHANGE
1	5-MAY-2004	V03	Added notch to pass GRN wire from front	1	PC	X
2	6-MAY-2004	V04	To match V2.00 changes	2	PC	X
3	NOV-05-2004	V05	HG:PC#6730:REMOVED EXTRA ROUTING BITS	3	PC	X
4	AUG-26-2005	V07	GT:CHANGES FOR 6V00 RELEASE. SEE HISTORY BOX	4	PC	X
5	2008/04/25	V08	Solder updates.	5	PC	X
6	2008/05/29	V09	PC#7590	6	PC	X

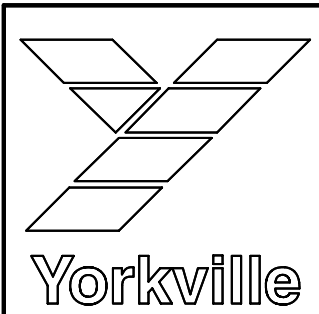
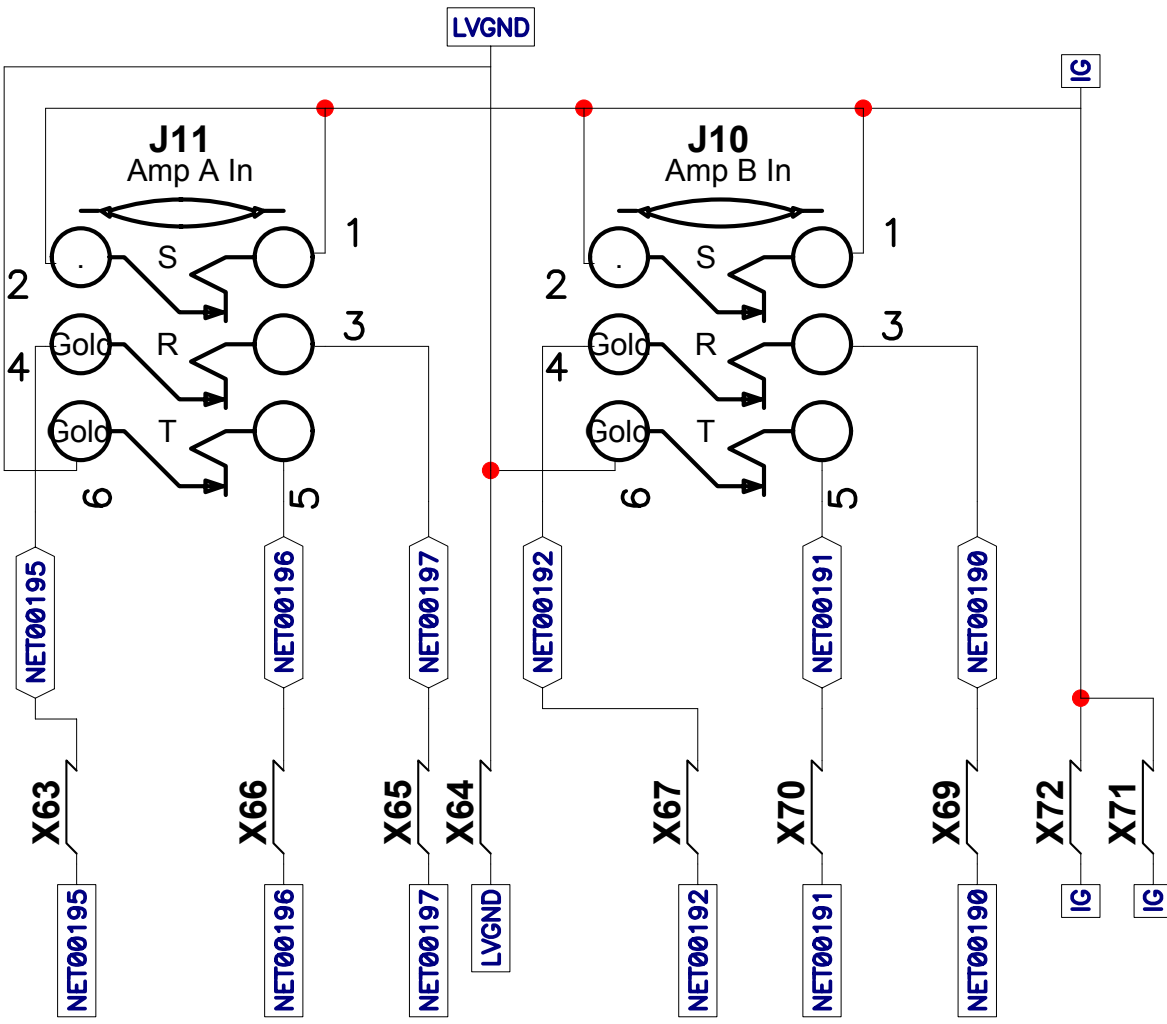

Product M1610		
Amp in Jacks	PCB# M1191	Sheet 1 of 2
Date: Tue Feb 10, 2004		Rev: V1.00
Filename: m1191 sch .sch2002		

StepAndRepeat - X9@1750:Y4@2000
BlankSize = 16.750 x 9.000

SHEAR OFF THIS SIDE SECOND

ETCH GUIDE

BlankSize = 16.750 x 9.000

SHEAR

SHEAR

SHEAR

SHEAR

FEED THIS SIDE INTO SHEARER FIRST

SHEAR OFF THIS SIDE FIRST

CLINCH ORIGIN

ETCH GUIDE

INSERT ORIGIN

Top Assy M1191v1.00

PRODUCTION NOTES

1. Shear off sides containing VCD origin and VCD finger tabs (top and bottom sides) before shearing the board into rows.
2. Feed board into shearer in the direction shown.
3. DO NOT remove the strip of board attached to each set of jumpers. It will keep the jumpers straight until they arrive in wiring.





Block Diagram for M810-2 / M1610-2

DESIGNED & MANUFACTURED BY YORKVILLE SOUND

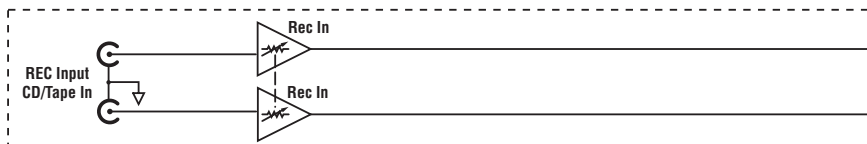

Mono Channel Input Details Channels 1-4

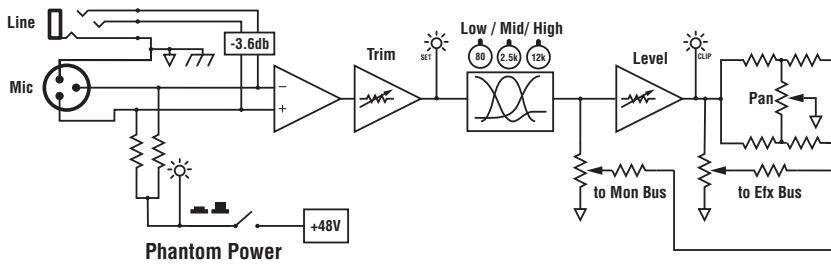

Mono Channel Input Details Channels 5-6

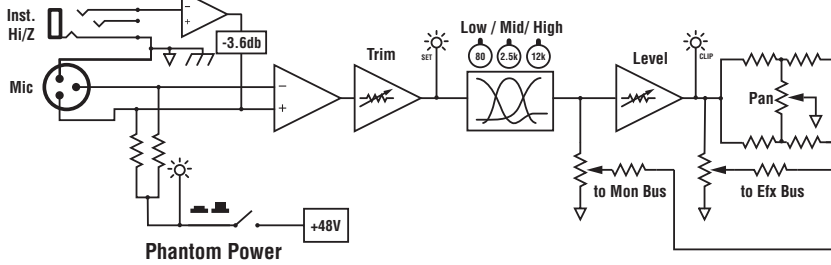

Stereo Channel Input Details Channels 7/8 & 9/10

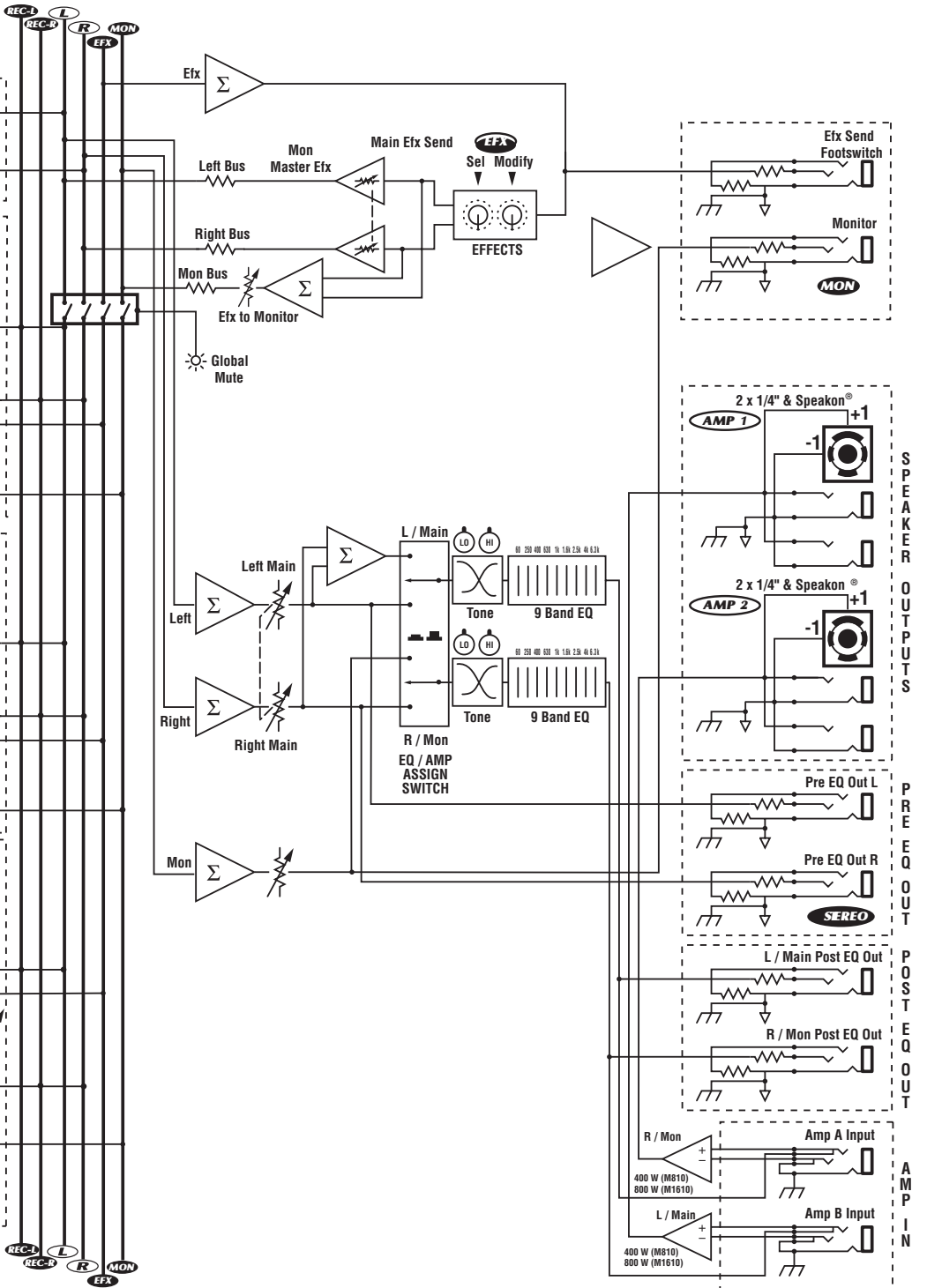
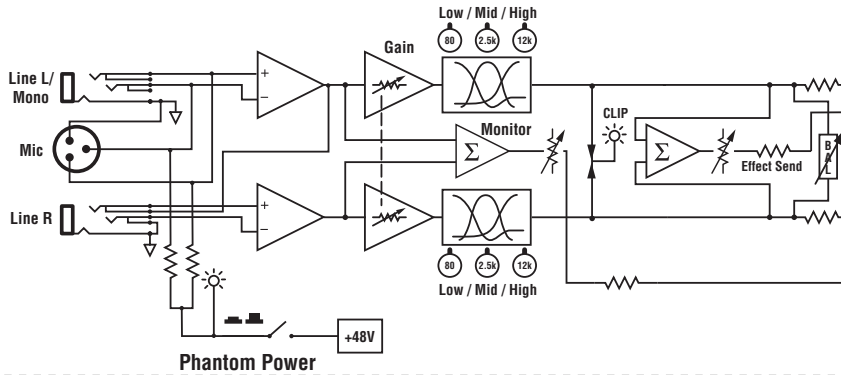

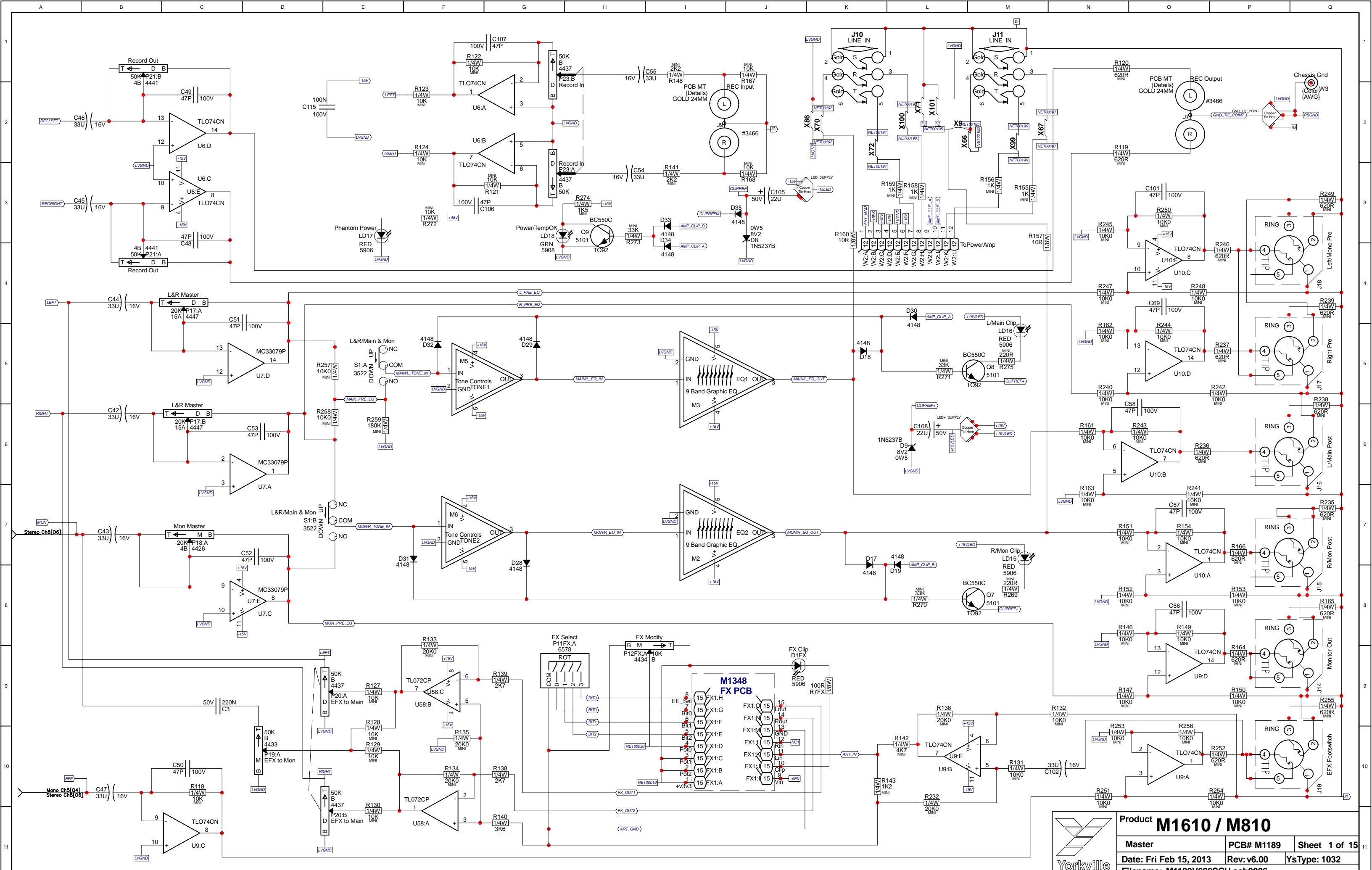

**Only Channel 1 is shown.
Channels 1 - 4 employ the
same circuit.**

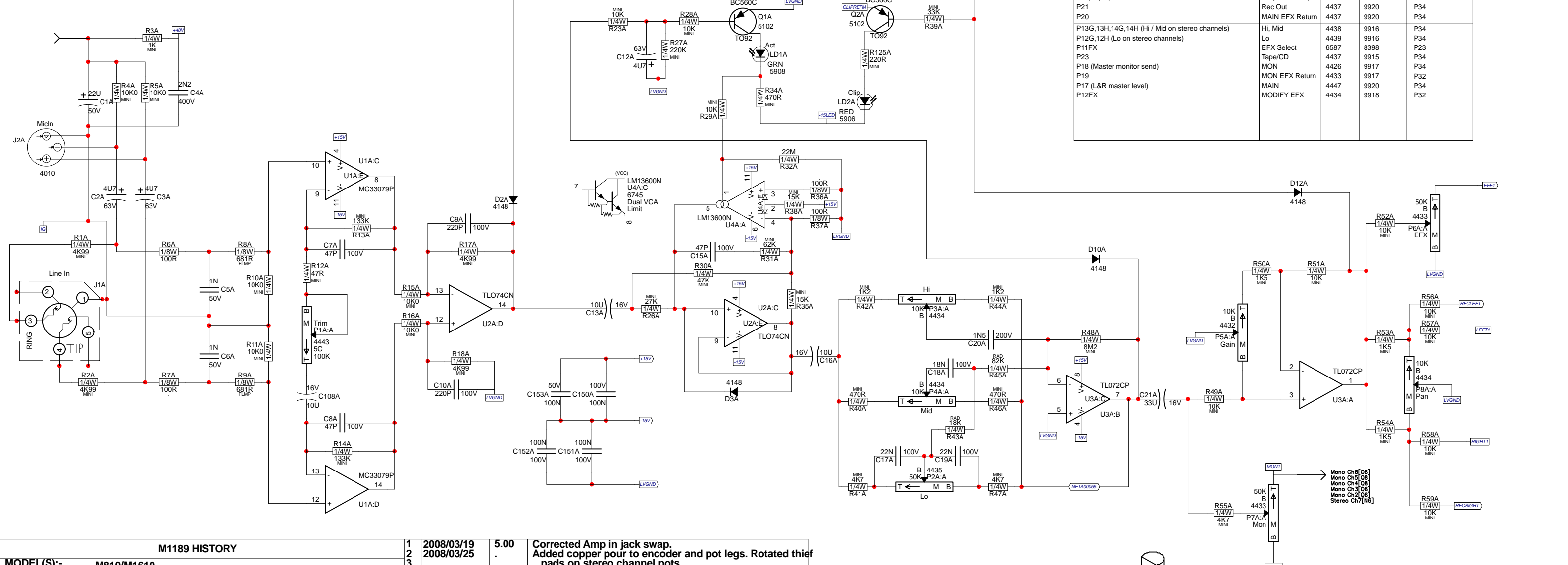

M1189 POTLIST				
MODEL(S):-		M1610		
REF	FUNCTION	PART#	KNOB	POT STYLE
P25-34 L&R	Graphic EQ	3998	N/A	S04
P1A,1B,1C,1D,1E,1F	Trim	4443	9915	P32
P9G,9H (Monitor sends on stereo channels)	Mon	4443	9917	P32
P5A,5B,5C,5D,5E,5F	Level	4432	9920	P32
P15G,15H,6A,6B,6C,6D,6E,6F	EFX	4433	9918	P32
P7A,7B,7C,7D,7E,7F (Monitor sends on mono channels)	Mon	4433	9917	P32
P3A-F,4A-F (Hi / Mid on mono channels)	Hi, Mid	4434	9916	P32
P16G,16H, 8A-F	Bal, Pan	4434	9919	P32
P2A,2B,2C,2D,2E,2F (Lo on mono channels)	Lo	4435	9916	P32
P35,36,37,38	Graphic EQ Lo, Hi	4435	9916	P32
P21	Rec Out	4437	9920	P34
P20	MAIN EFX Return	4437	9920	P34
P13G,13H,14G,14H (Hi / Mid on stereo channels)	Hi, Mid	4438	9916	P34
P12G,12H (Lo on stereo channels)	Lo	4439	9916	P34
P11FX	EFX Select	6587	8398	P23
P23	Tape/CD	4437	9915	P34
P18 (Master monitor send)	MON	4426	9917	P34
P19	MON EFX Return	4433	9917	P32
P17 (L&R master level)	MAIN	4447	9920	P34
P12FX	MODIFY EFX	4434	9918	P32

M1189 HISTORY			
MODEL(S):-	VER#	DATE	DESCRIPTION OF CHANGE
M810/M1610	1.00	31 Dec, 2003	Moved D3 anode to cathode of LD1
	1.00	2 Feb, 2004	Change break mute flash rate
	1.01	17 Feb, 2004	Move C7a-f, R13a-f to make room for AA series xlr.
	V	D	Change hole sizes for AA series xlr.
	V	D	Changed U1FX SRAM to 32kx8
	1.02	24 Feb, 2004	Changed 3925 XLRs to 4010 AA series
	2.00	7-APR-2004	PC#6675 Moved C150(A,C,E) to avoid hitting ICs
	V	D	Removed routing from board - slots done on drill now
	2.00	15-APR-2004	PC#6677 Chg X41 to C3(220n 50V), set gerber so TIE4 gets output properly
	V	D	PC#6679 Chg. C21(A,B,C,D,E,F) from 470nF to 33uF
	2.00	6-MAY-2004	PC#6686 MOVED C23FX AWAY FROM SPACER
	2.00	Aug 4, 2004	Fixed silk screen on U6FX and U2FX
	2.10	1 AUG-16-2004	PC#6718 CHANGE R140 TO 10K0 (6116), R138&R139 TO 9K09 (6112)
	V	D	PC#6771:#3571->#3507 SKT FOR #6993 SRAM (GT)
	2.11	NOV-23-2004	GT:PC#6792:P17 FROM 50KB #4441 TO 20KA #4447
	2.20	4 JAN-05-2005	Updated 3921 jacks for clinch.
	2.20	21 Apr, 2005	AH, PC#6816, ADD A HOLE FOR FEEDING GROUND WIRE
	V	D	N
	2.30	14 JUN 2006	AH, PC#7091, UPDTAE #5322 CHANGE DRILL SIZE TO 403
	V	D	PC#6989, STRENGTHEN RCA JACK SECTION BREAKAWAY
	3.00	11 JAN-2008	#4581 UPDATING, PROPER DRILLING ORDER
	V	D	PC#7325, FORCE UPDATE PARTS FOR NEW PAD TYPE
	4.00	2008/02/20	PC#7330, REMOVE EXTRA PADS FROM U1FX AND U3FX New DFX, solder updates, add amp in jacks, link for tie4

1	2008/03/19	5.00	Corrected Amp in jack swap.
2	2008/03/25	.	Added copper pour to encoder and pot legs. Rotated thief pads on stereo channel pots.
3	.	.	Added scoring tooling holes.
4	2008/04/18	.	Changed XLR jacks to minimum outline.
5	2008/06/19	.	PC#7868 - changed to standoff nuts. Add X102.
6	2009/09/18	6.00	PC#7876 - Ribbon cable change. Modified some pads on dual pots to prevent solder bridging. D1->25mil
7	2009/09/24	6.00	PC#7878 - Make ampin jack breakouts smaller.
8	.	.	Fixed Pots List. - ML
9	.	.	N
10	2013/02/15	.	N
11	D	V	N
12	D	V	N
13	D	V	N

M1189 DRILL HISTORY			
MODEL(S):-	VER#	DATE	DESCRIPTION OF CHANGE
M810/M1610	V01	24-FEB-2004	N
	V02	21-APR-2005	N
	V03	4-AUG-2005	PC#6818, ADDING A HOLE FOR FEEDING GREEN GND
	V04	2008/02/20	N
	V05	2008/04/18	N
	V	D	N

M1189 PENDING CHANGES			
MODEL(S):-	PC#	DATE	PENDING CHANGE
M1610	1	PC	X
	2	PC	X
	3	PC	X
	4	PC	X
	5	PC	X
	6	PC	X

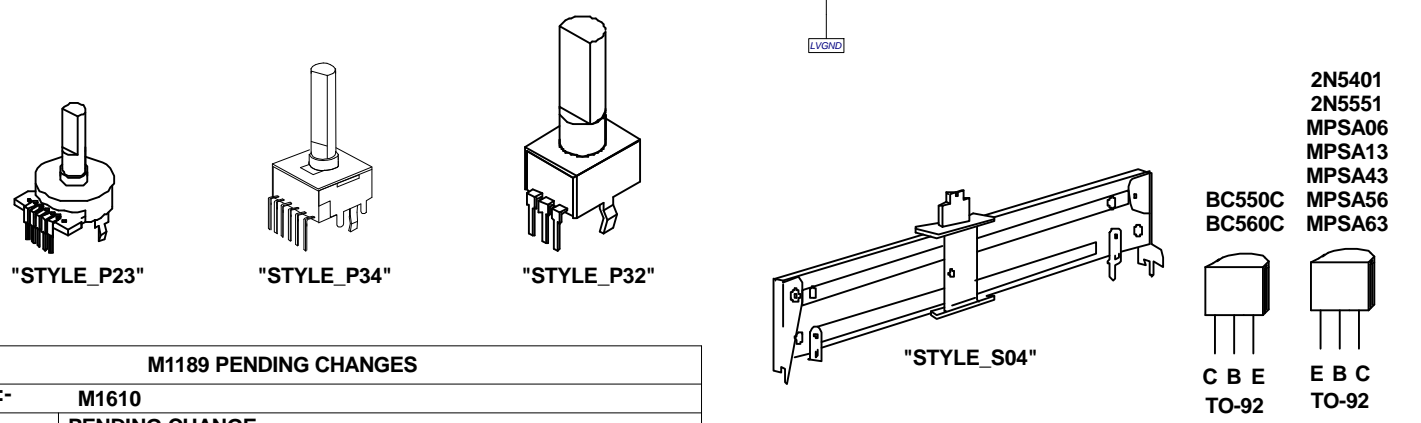

Product **M1610 / M810**

Mono Ch1 PCB# M1189 Sheet 2 of 15

Date: Fri Feb 15, 2013 Rev:v6.00 YsType: 1032

Filename: M1189V600SCH.sch2006

*PLACE IMPLEMENTED CHANGES INTO BOARD HISTORY

**Only Channel 5 is shown.
Channels 5 & 6 employ
the same circuit.**

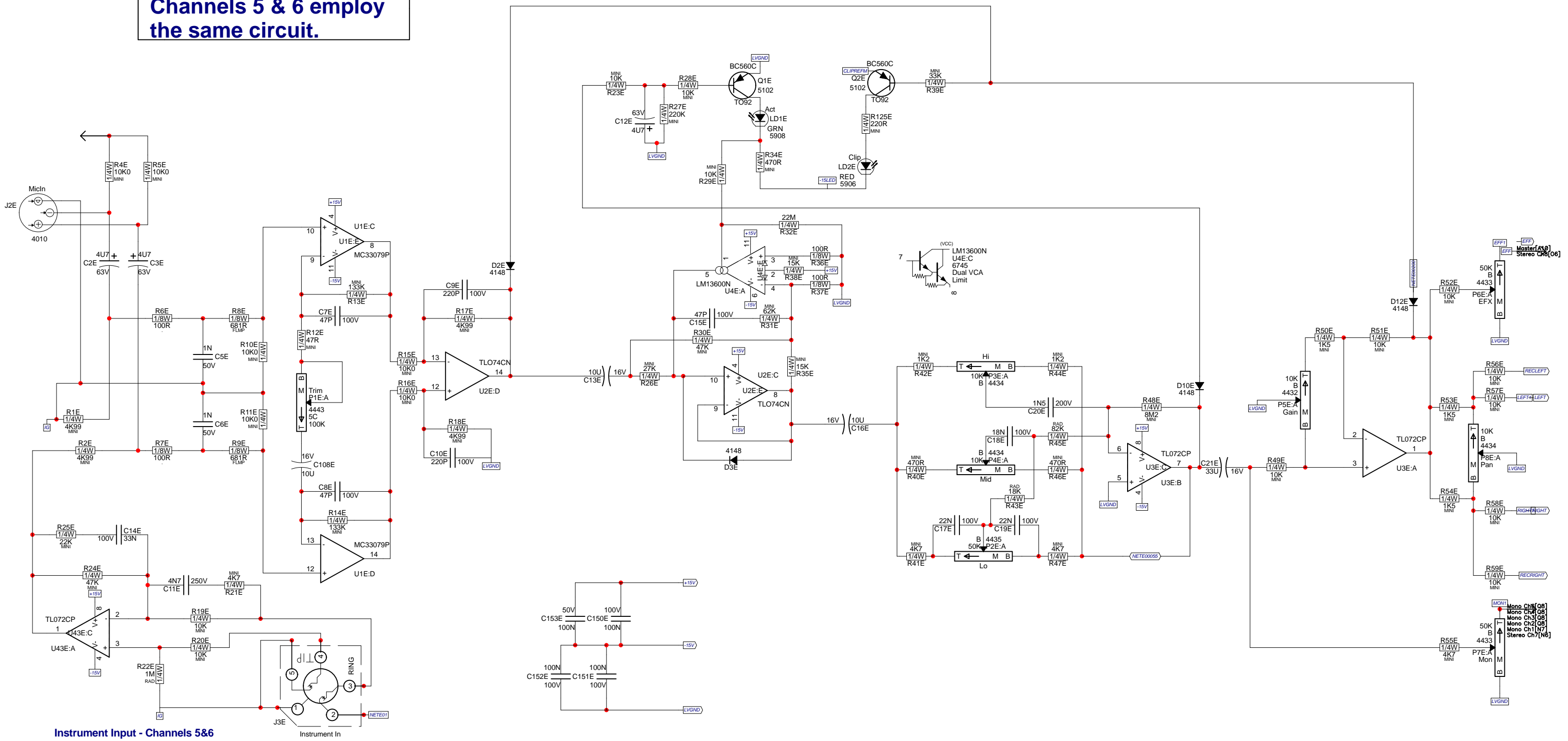

Instrument Input - Channels 5&6

**Only channels 7&8 are shown.
Channels 9&10 employ
the same circuit.**

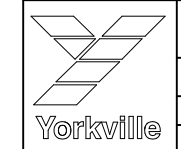
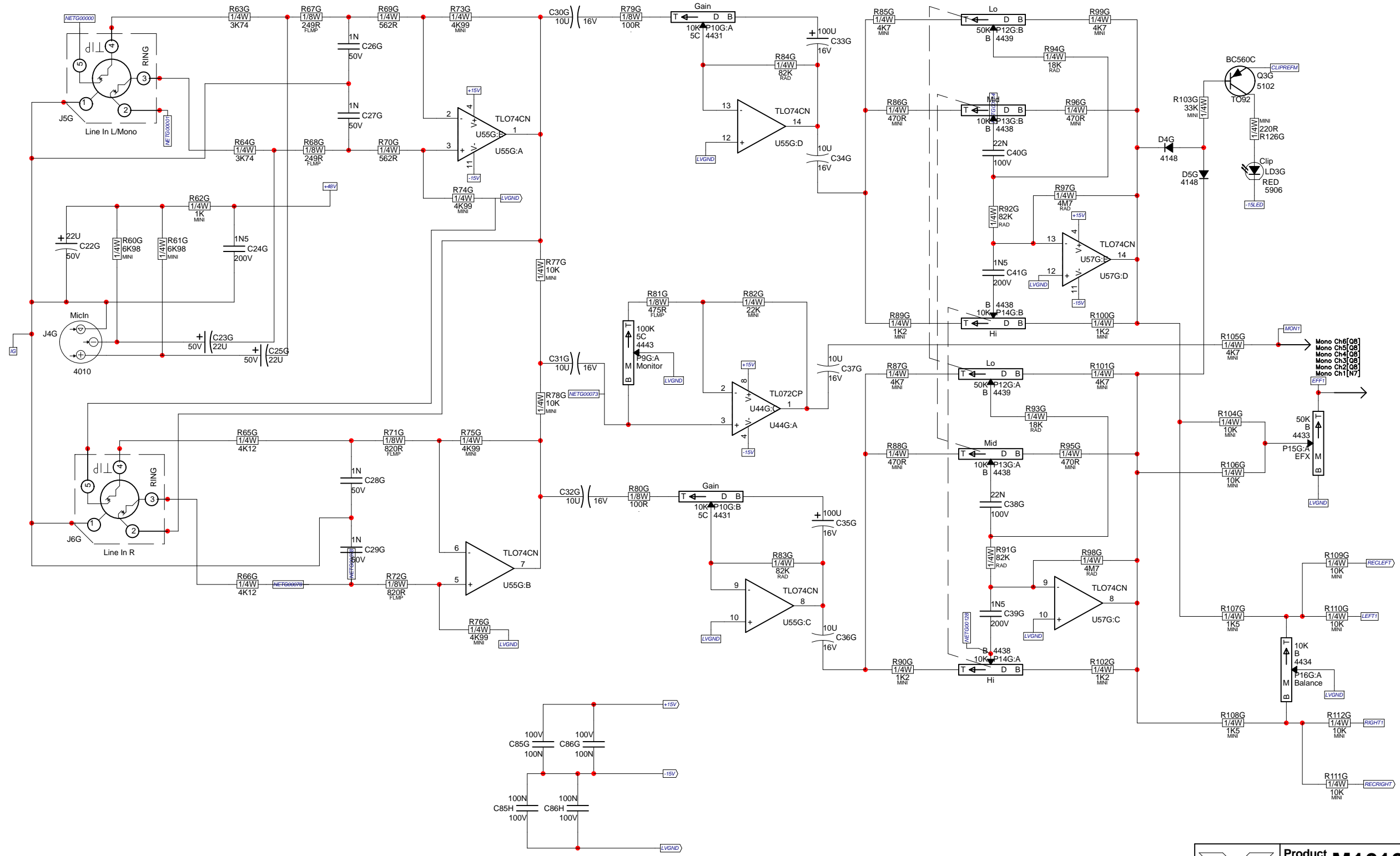

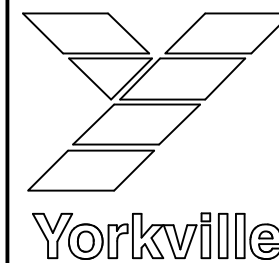
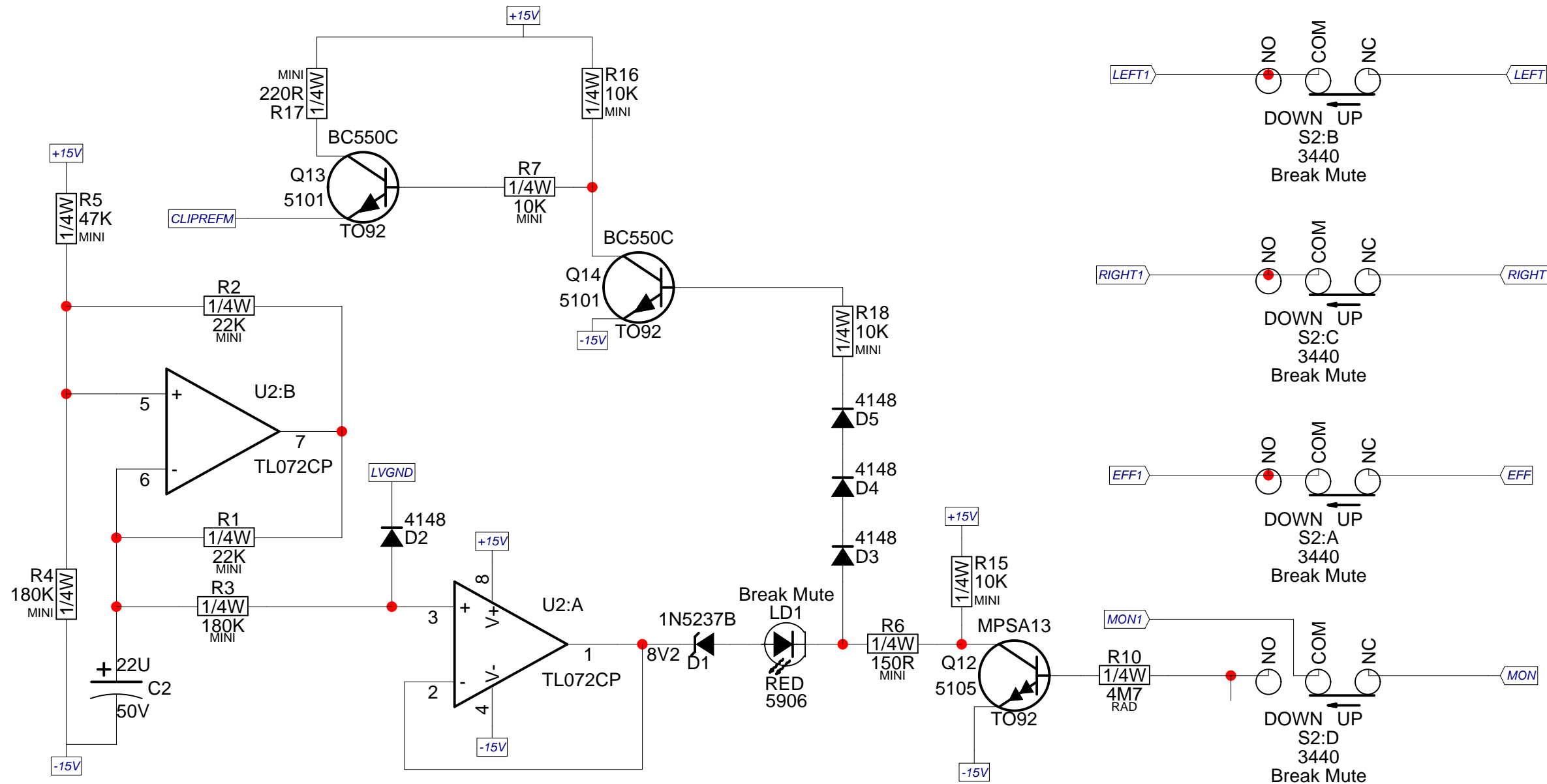

Product **M1610 / M810**

BreakMute

PCB# M1189

Sheet 10 of 15

Date: Fri Feb 15, 2013

Rev:v6.00

YsType:1032

Filename: M1189V600SCH.sch2006

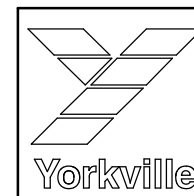
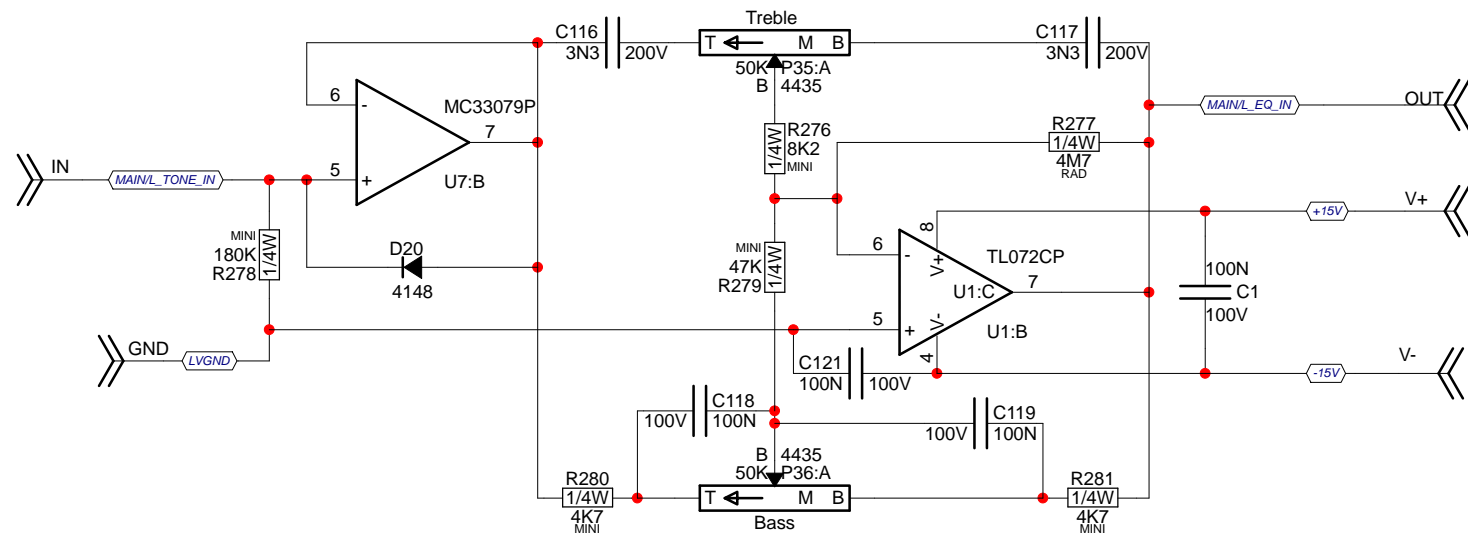

Product M1610 / M810		
TONE1	PCB# M1189	Sheet 11 of 15
Date: Fri Feb 15, 2013	Rev:v6.00	YsType: 1032
Filename: M1189V600SCH.sch2006		

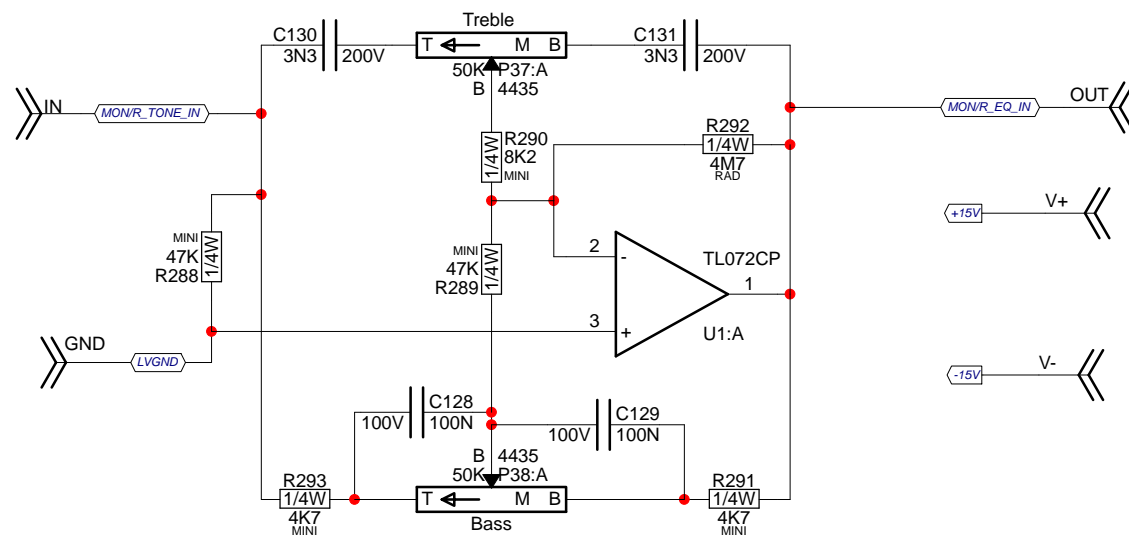

	Product M1610 / M810		
	TONE2	PCB# M1189	Sheet 12 of 15
	Date: Fri Feb 15, 2013	Rev: v6.00	YsType: 1032
	Filename: M1189V600SCH.sch2006		

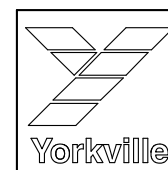
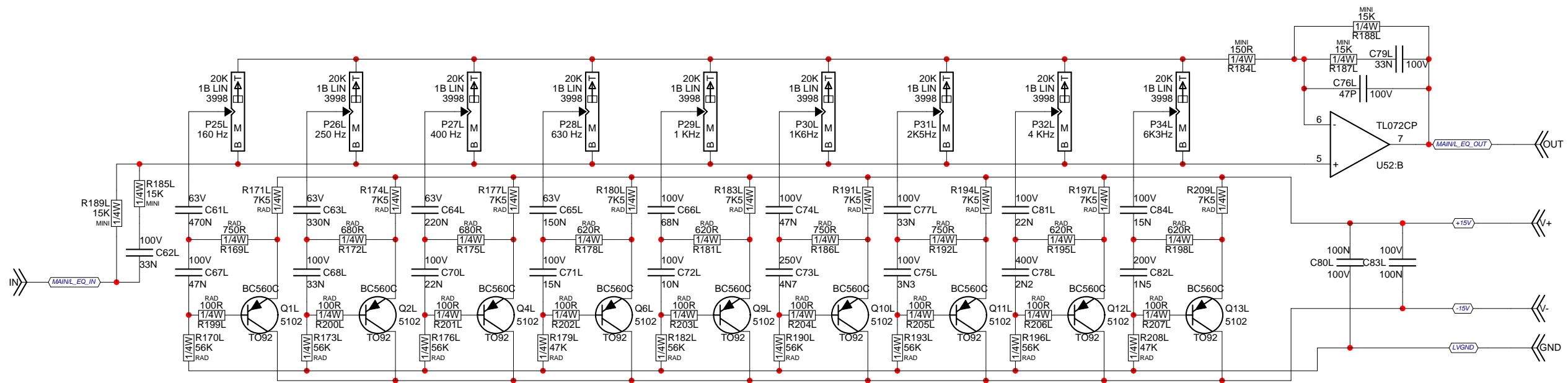

Product M1610 / M810		
EQ1	PCB# M1189	Sheet 13 of 15
Date: Fri Feb 15, 2013	Rev: v6.00	YsType: 1032
Filename: M1189V600SCH.sch2006		



M1189
M1610 / M810
V6.00

00.0V 881FM
SC01- eqvT 2Y
YS Type - 1032

BlankSize - 17900x10750

BlankSize - 17900x10750

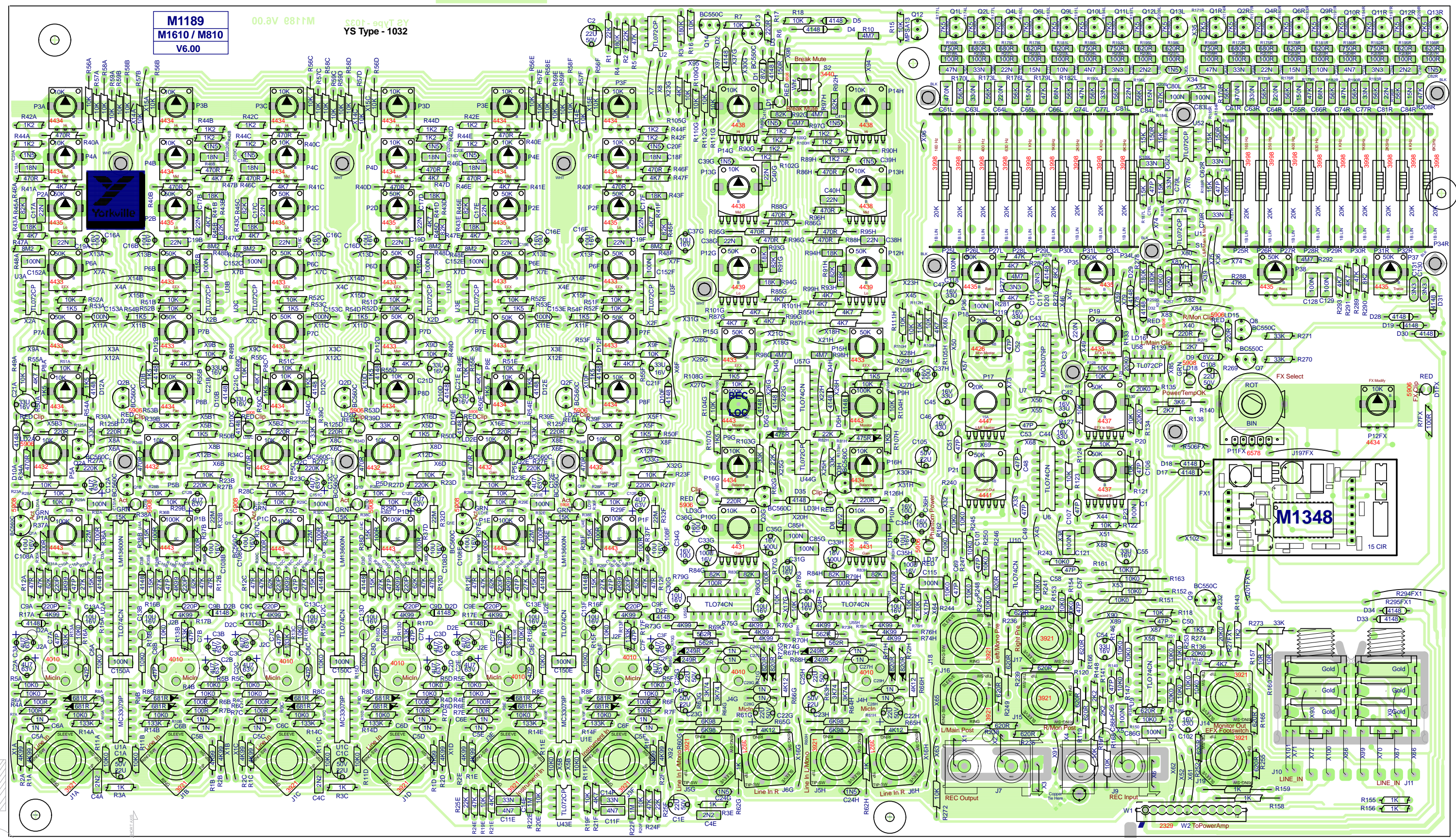

SEE LAYOUT DOCUMENTATION





SEE LAYOUT DIAGRAM

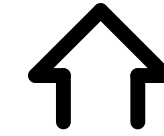

M1189 PRODUCTION NOTES

1. PCBSA: BREAK OUT BOARD BEFORE TESTING.

M1189 POTLIST				
MODEL(S):-		M1610		
REF	FUNCTION	PART#	KNOB	POT STYLE
P25-34 L&R	Graphic EQ	3998	N/A	S04
P1A,1B,1C,1D,1E,1F	Trim	4443	9915	P32
P9G,9H (Monitor sends on stereo channels)	Mon	4443	9917	P32
P5A,5B,5C,5D,5E,5F	Level	4432	9920	P32
P15G,15H,6A,6B,6C,6D,6E,6F	EFX	4433	9918	P32
P7A,7B,7C,7D,7E,7F (Monitor sends on mono channels)	Mon	4433	9917	P32
P3A-F,4A-F (Hi / Mid on mono channels)	Hi, Mid	4434	9916	P32
P16G,16H, 8A-F	Bal, Pan	4434	9919	P32
P2A,2B,2C,2D,2E,2F (Lo on mono channels)	Lo	4435	9916	P32
P35,36,37,38	Graphic EQ Lo, Hi	4435	9916	P32
P21	Rec Out	4441	9920	P34
P20	MAIN EFX Return	4437	9920	P34
P13G,13H,14G,14H (Hi / Mid on stereo channels)	Hi, Mid	4438	9916	P34
P12G,12H (Lo on stereo channels)	Lo	4439	9916	P34
P11FX	EFX Select	6587	8398	P23
P23	Tape/CD	4437	9915	P34
P18 (Master monitor send)	MON	4426	9917	P34
P19	MON EFX Return	4433	9917	P32
P17 (L&R master level)	MAIN	4447	9920	P34
P12FX	MODIFY EFX	4434	9918	P32

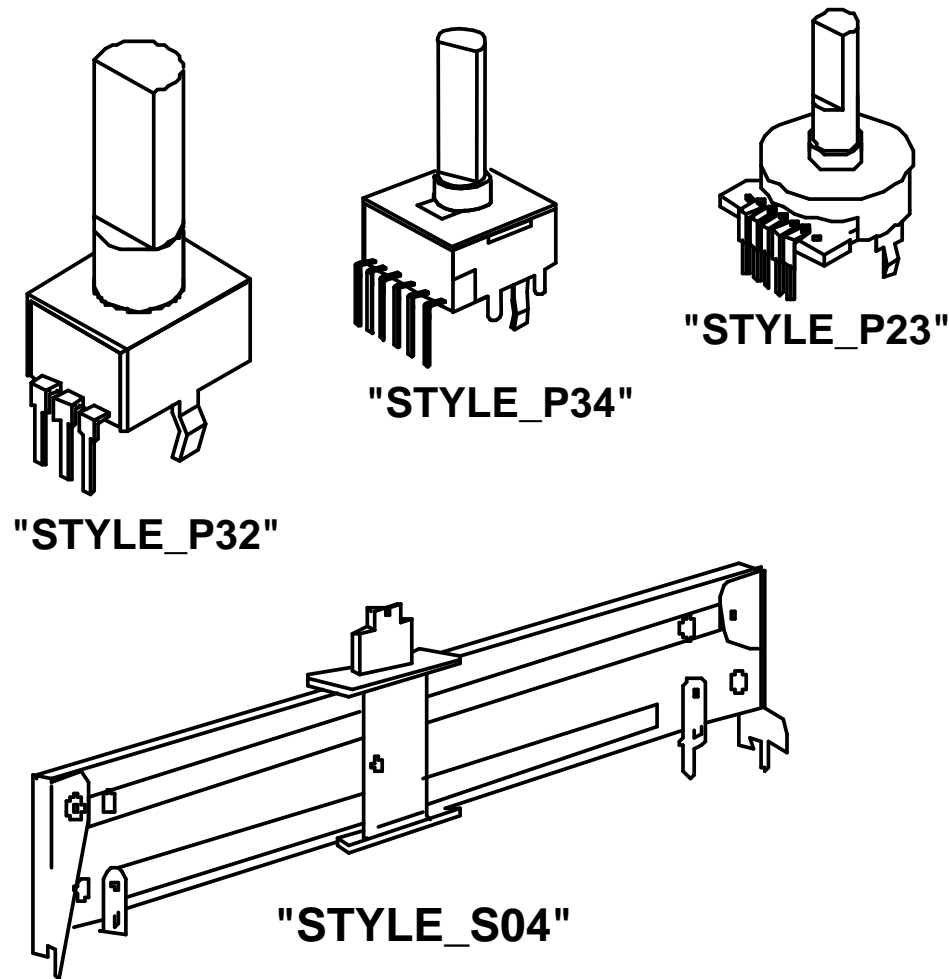

- 2N5401
- 2N5551
- MPSA06
- MPSA13
- MPSA43
- MPSA56
- MPSA63
- BC550C
- BC560C
- TO-92
- TO-92

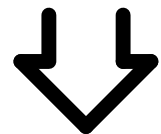

SEE PRODUCT HISTORY

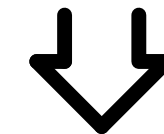



SEE PRODUCTION NOTES



M1189 HISTORY				M1189 PENDING CHANGES			
MODEL(S):- M1610				MODEL(S):- M1610			
#	DATE	VER#	DESCRIPTION OF CHANGE	#	PC#	PENDING CHANGE	
1	31 Dec, 2003	v1.00p3	Moved D3 anode to cathode of LD1	1	PC	X	*PLACE IMPLEMENTED CHANGES INTO BOARD HISTORY
2	2 Feb, 2004	1.00	Change break mute flash rate	2	PC	X	
3	17 Feb, 2004	1.01	Move C7a-f, R13a-f to make room for AA series xlr.	3	PC	X	
4	.	.	Change hole sizes for AA series xlr.	4	PC	X	
5	.	.	Changed U1FX SRAM to 32kX8	5	PC	X	
6	24 Feb, 2004	1.02	Changed 3925 XLRs to 4010 AA series	6	PC	X	
7	7-APR-2004	2.00	PC#6675 Moved C150(A,C,E) to avoid hitting ICs	M1189 DRILL HISTORY			
8	.	.	Removed routing from board - slots done on drill now				
9	15-APR-2004	2.00	PC#6677 Chg X41 to C3(220n 50V), set gerber	MODEL(S):- M810/M1610			
10	.	.	so TIE4 gets output properly	#	DATE	VER#	DESCRIPTION OF CHANGE
11	.	.	PC#6679 Chg. C21(A,B,C,D,E,F) from 470nF to 33uF	1	24-FEB-2004	V01	N
12	6-MAY-2004	2.00	PC#6686 MOVED C23FX AWAY FROM SPACER	2	21-APR-2005	V02	N
13	Aug 4, 2004	2.00	Fixed silk screen on U6FX and U2FX	3	4-AUG-2005	V03	N
1	AUG-16-2004	2.10	PC#6718 CHANGE R140 TO 10K0 (6116),	4	2008/02/20	V04	N
2	D	V	R138&R139 TO 9K09 (6112)	5	2008/04/18	V05	N
3	NOV-23-2004	.	PC#6771:#3571->#3507 SKT FOR #6993 SRAM (GT)	6	D	V	N
4	JAN-05-2005	.	GT:PC#6792:P17 FROM 50KB #4441 TO 20KA #4447				
5	21 Apr, 2005	2.11	Updated 3921 jacks for clinch.				
6	4 Aug 2005	2.20	AH, PC#6816, ADD A HOLE FOR FEEDING GREEN				
7	.	.	GROUND WIRE.				
8	14 JUN 2006	2.30	AH, PC#7091, UPDTAE #5322 CHANGE DRILL SIZE TO 40				
9	.	.	PC#6989, STRENGTHEN RCA JACK SECTION BREAKAWAY				
10	.	.	#4581 UPDATED, PROPER DRILLING ORDER				
11	11-JAN-2008	3.00	PC#7325, FORCE UPDATE PARTS FOR NEW PAD TYPE				
12	.	.	PC#7330, REMOVE EXTRA PADS FROM U1FX AND U3FX				
13	2008/02/20	4.00	New DFX, solder updates, add amp in jacks, link for tie4				
1	2008/03/19	5.00	Corrected Amp in jack swap.				
2	2008/03/25	.	Added copper pour to encoder and pot legs. Rotated thief				
3	.	.	pads on stereo channel pots.				
4	2008/04/18	.	Added scoring tooling holes.				
5	20080619	.	Changed XLR jacks to minimum outline.				
6	2009/09/18	6.00	PC#7868 - changed to standoff nuts. Add X102.				
7	2009/09/24	6.00	PC#7876 - Ribbon cable change. Modified some pads on				
8	.	.	dual pots to prevent solder bridging. D1--> 25MIL				
9	.	.	PC#7878 - Make ampin jack breakouts smaller.				
10	2013/02/15	.	Fixed Pots List. - ML				
11	D	V	N				
12	D	V	N				
13	D	V	N				

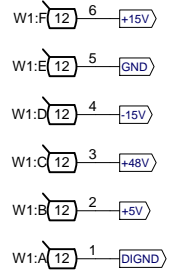
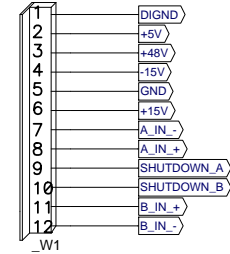
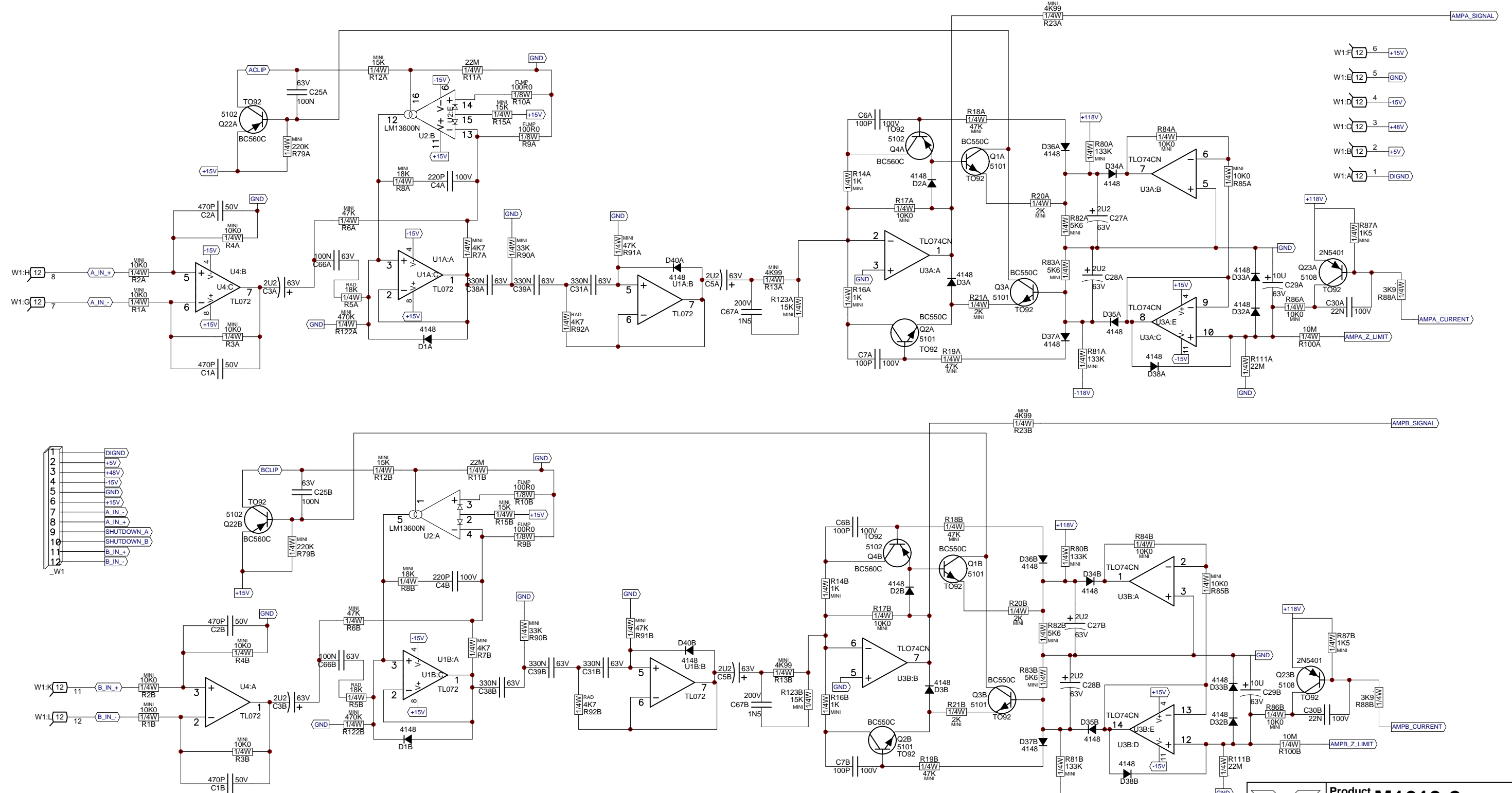

Product M1610-2		
Ampln	PCB# M1190	Sheet 1 of 4
Date: Thu Dec 10, 2015	Rev:V15	YsType:.
Filename: M1190V15SCH.sch2006		

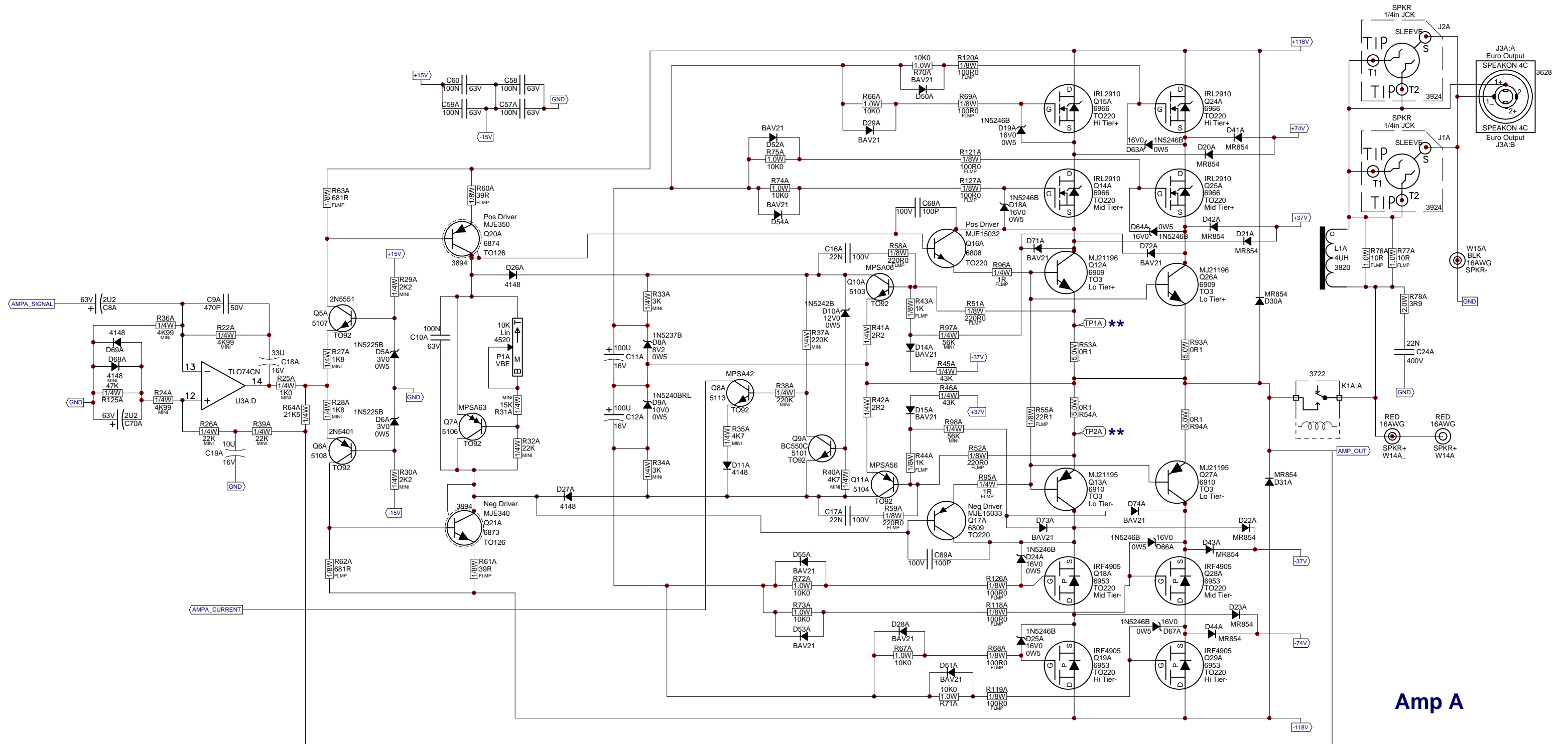

Amp A

**** ADJUST P1A FOR 8mV ACCROSS TP1A AND TP2A.**

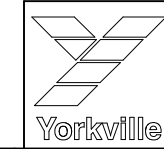

Product M1610-2		
Channel A	PCB# M1190	Sheet 2 of 4
Date: Thu Dec 10, 2015	Rev:V15	YsType:.
Filename: M1190V15SCH.sch2006		

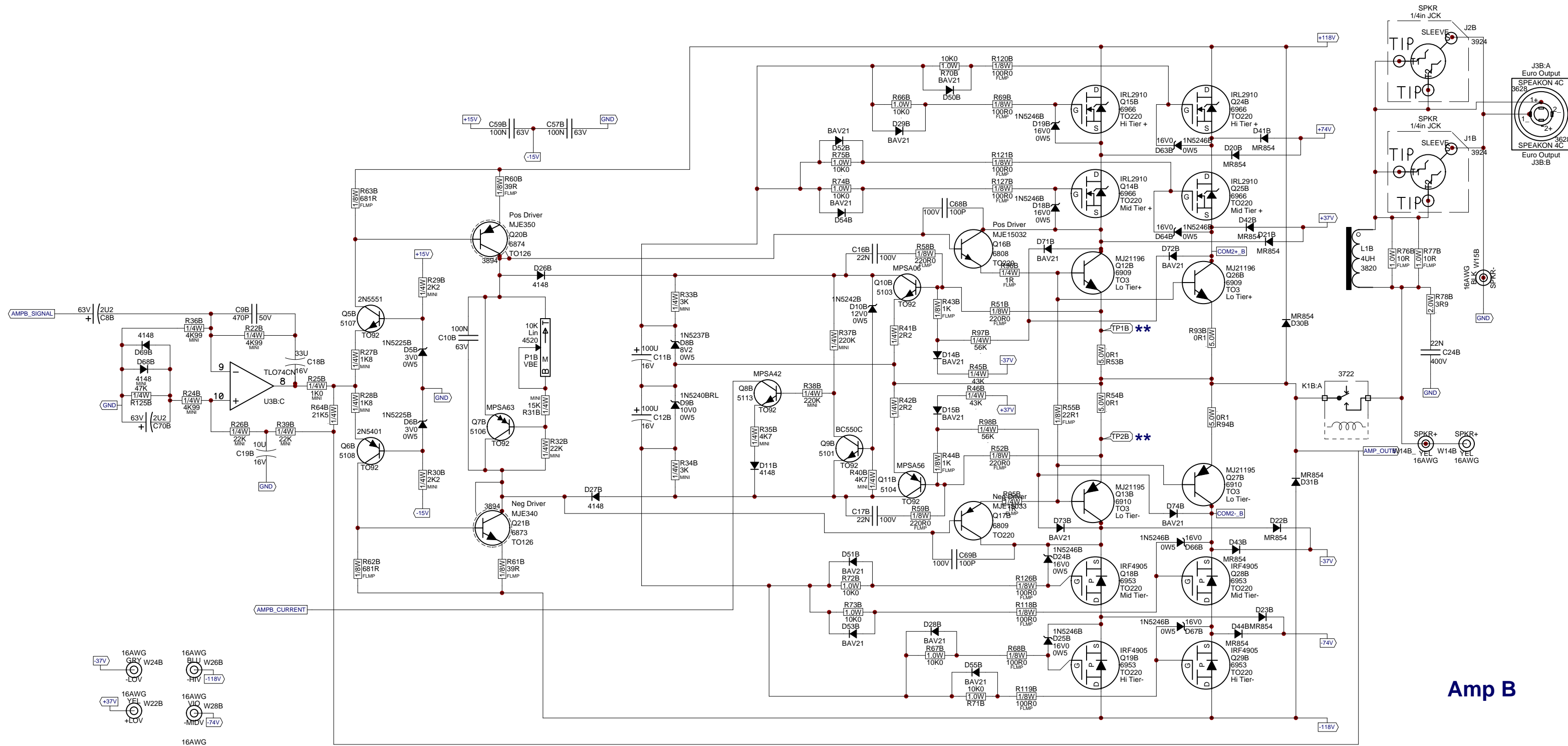

- 37V GRY W24B -LOV
- 37V YEL W22B -LOV
- 118V W26B -HIV
- 74V W28B -MIDV
- 74V W20B +MIDV
- 118V W17B -HIV

**** ADJUST P1B FOR 8mV ACCROSS TP1B AND TP2B.**

Amp B

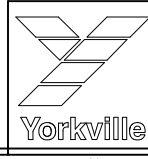
Product M1610-2
Channel B **PCB# M1190** **Sheet 3 of 4**
Date: Thu Dec 10, 2015 **Rev:V15** **YsType:..**
Filename: M1190V15SCH.sch2006

M1190.PCB_DATABASE_HISTORY			
MODEL(S):-	M1610	#	DATE
1	7 Jan, 2004	1.00	24
2	24 Feb, 2004	1.00	25
3	10 Mar, 2004	1.00	26
4	21-APR-2004	1.00	27
5	6-MAY-2004	2.00	28
6	D	V	29
7	D	V	30
8	DEC-14-2004	3.00	31
9	FEB-07-2005	4.00	32
10	D	V	33
11	D	V	34
12	D	V	35
13	D	V	36
14	MAR-30-2005	5.00	37
15	MAR-13-2005	5.10	38
16	D	V	39
17	21 Apr, 2005	5.11	40
18	JUN-08-2005	6.00	41
19	.	.	42
20	.	.	43
21	.	.	44
22	.	.	45
23	.	.	46

#	DATE	VER#	DESCRIPTION OF CHANGE	#	DATE	VER#	DESCRIPTION OF CHANGE
24	.	.	R79A&B #6127 470K->#6127 220K	24	.	.	R79A&B #6127 470K->#6127 220K
25	.	.	ADDED D4 #5124 5V1/5W, R97&R98 #2006 1R/1W->#5124	25	.	.	ADDED D4 #5124 5V1/5W, R97&R98 #2006 1R/1W->#5124
26	.	.	Corrected the position of some test nodes.	26	.	.	Corrected the position of some test nodes.
27	.	.	Fixed BlankSize field	27	.	.	Fixed BlankSize field
28	Jun-15-2006	7.00	AH, PC#7021, SPACE BETWEEN R96 AND R53	28	Jun-15-2006	7.00	AH, PC#7021, SPACE BETWEEN R96 AND R53
29	.	.	PC#6983, WIDEN TRACE BETWEEN C32 AND C37	29	.	.	PC#6983, WIDEN TRACE BETWEEN C32 AND C37
30	.	.	PC#7091, ENLARGE HOLE SIZE FOR #3522	30	.	.	PC#7091, ENLARGE HOLE SIZE FOR #3522
31	2008/04/07	v8.0p0	Swap c37 with c51; c51 with c36. Moved x11b & x31b to middle of HS slots. Solder updates, part updates.	31	2008/04/07	v8.0p0	Swap c37 with c51; c51 with c36. Moved x11b & x31b to middle of HS slots. Solder updates, part updates.
32	2008/04/25	v8.00	Changed Q8a&b from 5107 to 5113 - MPSA42	32	2008/04/25	v8.00	Changed Q8a&b from 5107 to 5113 - MPSA42
33	2008/05/29	9.00	PC#7590 - PS hum fix. Moved K1B away from X15B.	33	2008/05/29	9.00	PC#7590 - PS hum fix. Moved K1B away from X15B.
34	2009/11/09	10.00	PC#7875, 7876 - Ribbon cable change - XTR screws flipped	34	2009/11/09	10.00	PC#7875, 7876 - Ribbon cable change - XTR screws flipped
35	03-FEB-2010	11.00	PC#7942, PC#7980: Update #4XTO220-MTG	35	03-FEB-2010	11.00	PC#7942, PC#7980: Update #4XTO220-MTG
36	04-FEB-2010	11.00	PC#7983: Change D2,D3,D4 #5124 span to .525	36	04-FEB-2010	11.00	PC#7983: Change D2,D3,D4 #5124 span to .525
37	10-JUN-2010	12.00	PC#7806 Change transistor pattern. PT	37	10-JUN-2010	12.00	PC#7806 Change transistor pattern. PT
38	15-MAY-2012	V13	PC#8383 - New double sided PCB released. - ML	38	15-MAY-2012	V13	PC#8383 - New double sided PCB released. - ML
39	15-MAY-2012	V14	PC#8423 - Changed NTC thermistors to YS#6619. - ML	39	15-MAY-2012	V14	PC#8423 - Changed NTC thermistors to YS#6619. - ML
40	21-JUN-2012	V15	Fixed BEC LOC short to heatsink. - ML	40	21-JUN-2012	V15	Fixed BEC LOC short to heatsink. - ML
41	09-DEC-2015	V15	PC#8734 1N4007 DIODES ADDED TO U5 and U6 -MZ IMPLEMENTED ON BOARD	41	09-DEC-2015	V15	PC#8734 1N4007 DIODES ADDED TO U5 and U6 -MZ IMPLEMENTED ON BOARD
42	.	.		42	.	.	
43	.	.		43	.	.	
44	.	.		44	.	.	
45	.	.		45	.	.	
46	.	.		46	.	.	
47	.	.		47	.	.	
48	.	.		48	.	.	
49	.	.		49	.	.	
50	.	.		50	.	.	

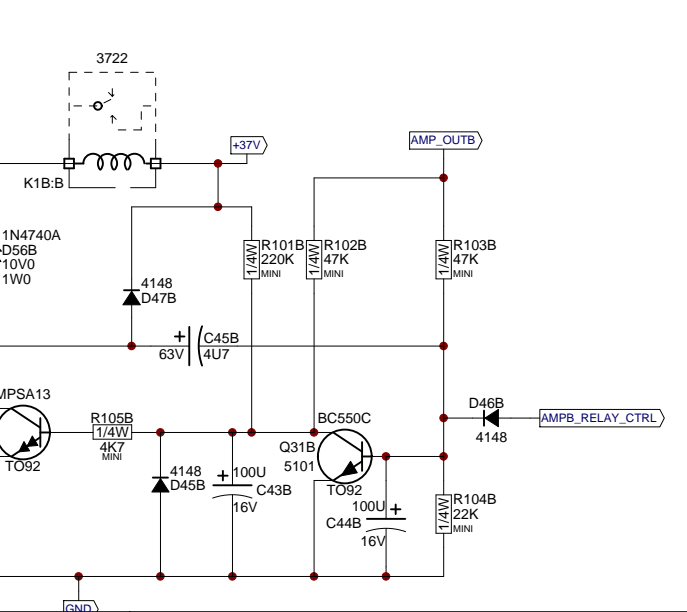
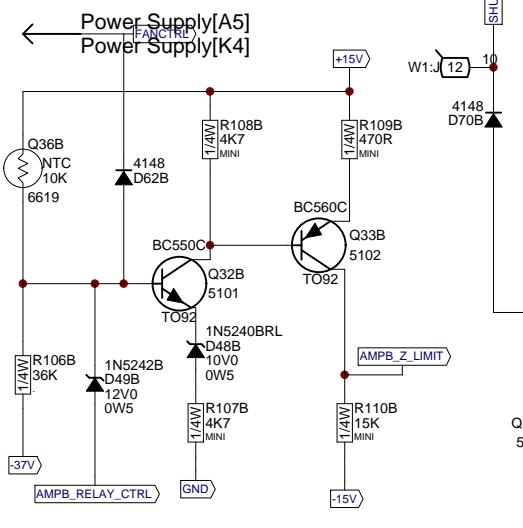
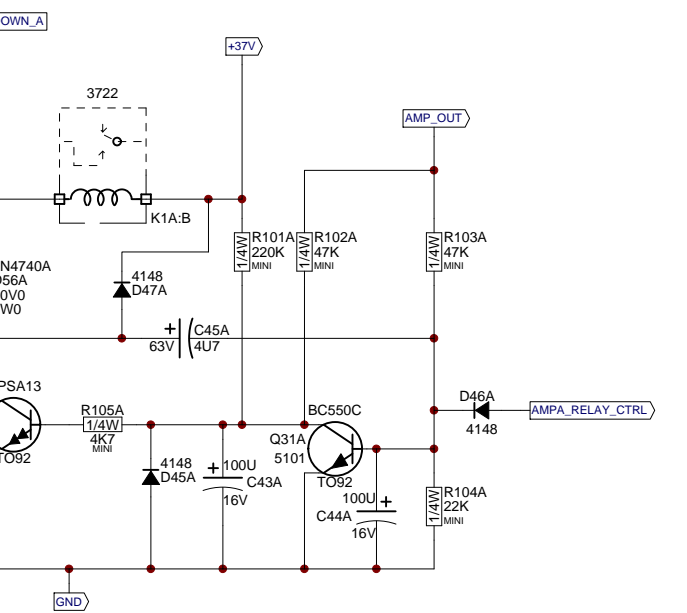
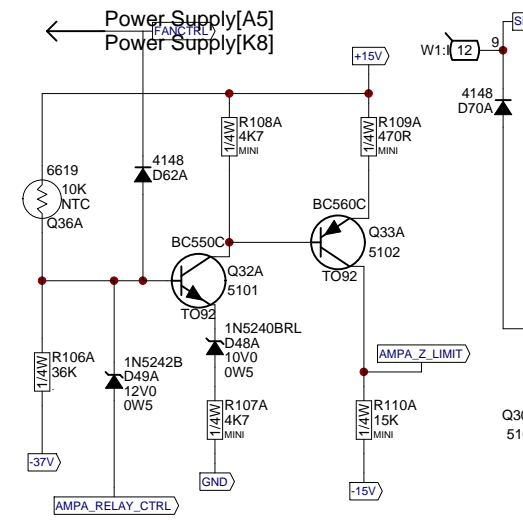
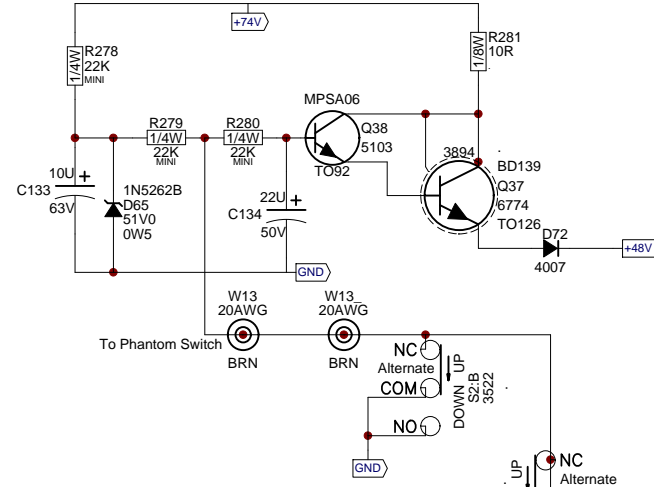
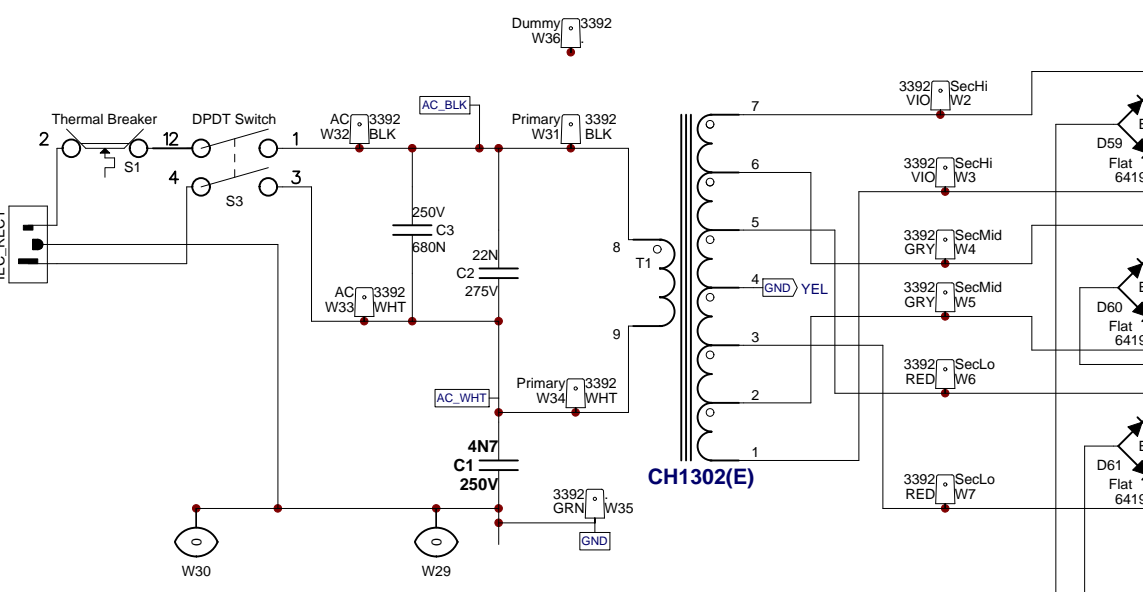
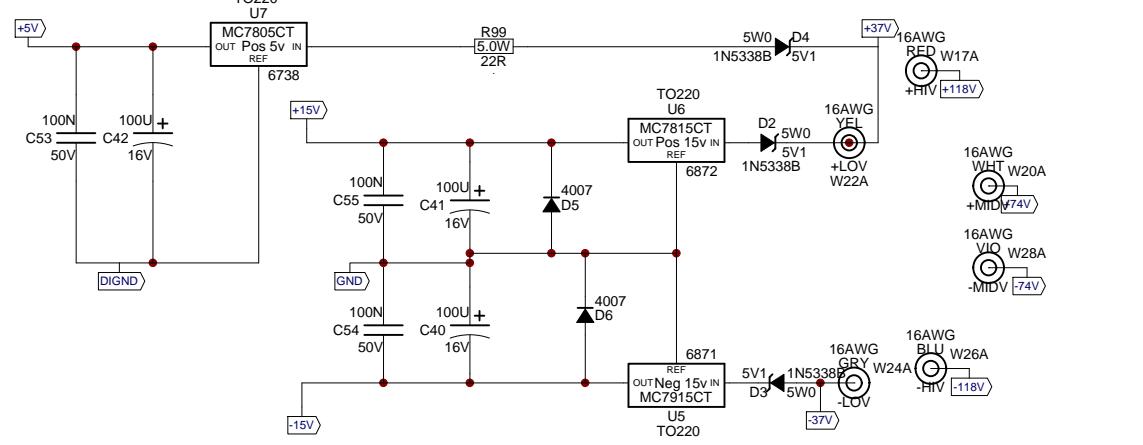
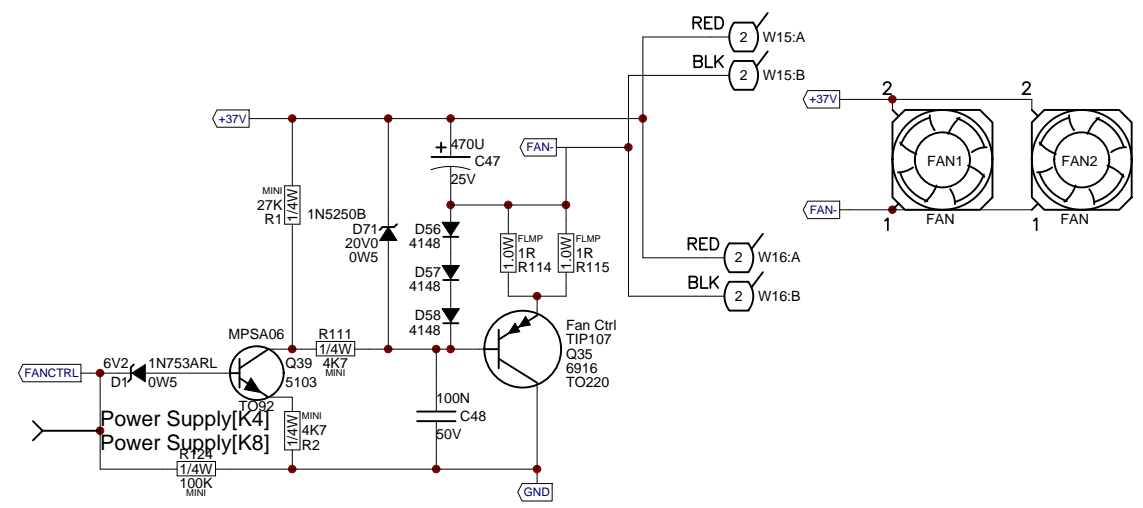

(E) DENOTES EUROPEAN

Yorkville

Product **M1610-2**

Power Supply	PCB# M1190	Sheet 4 of 4
Date: Thu Dec 10, 2015	Rev:V15	YsType:..
Filename: M1190V15SCH.sch2006		

Wave Solder

BlankSize - 17900x10600



BlankSize - 17900x10600

Heatsink covers this area

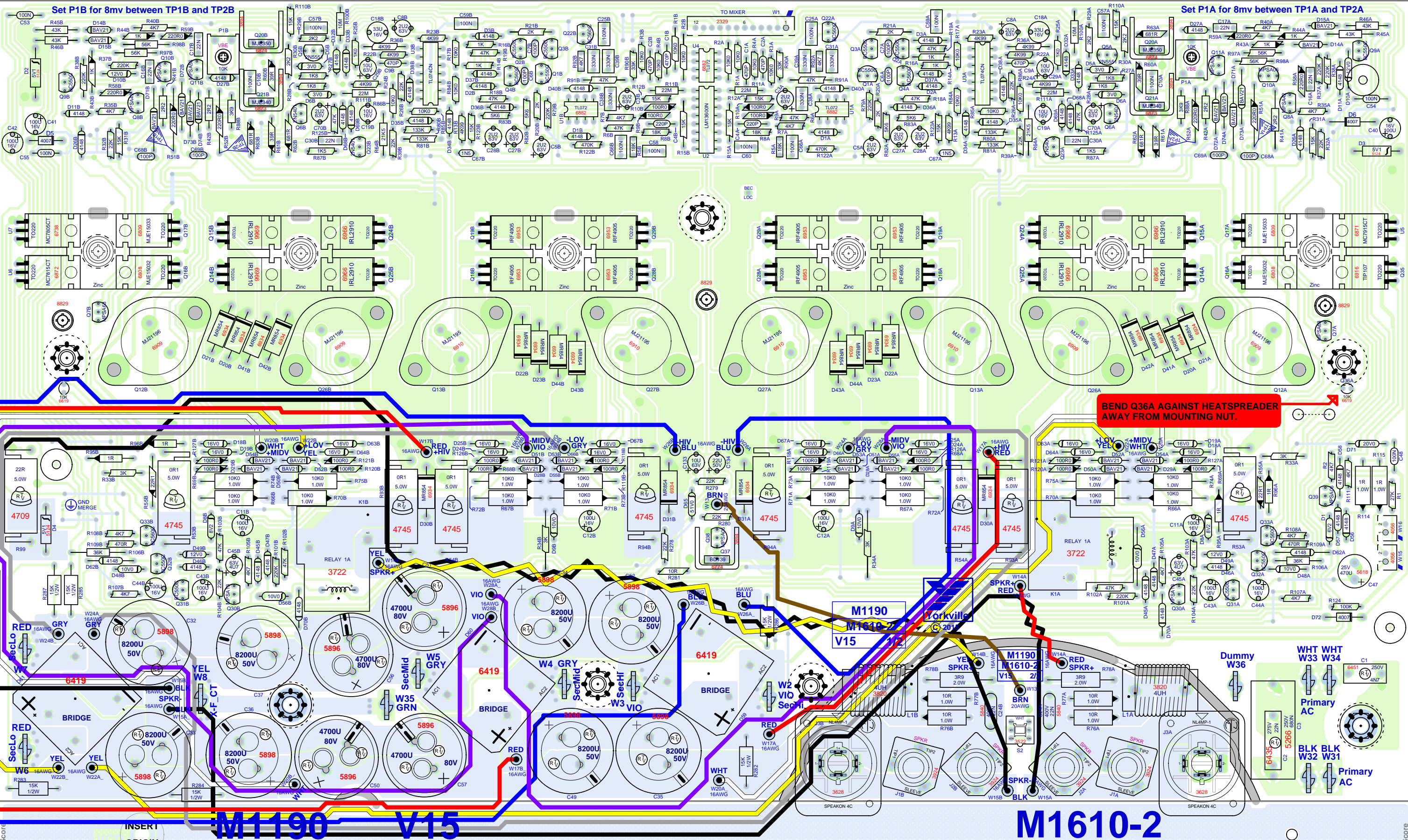

Set P1B for 8mv between TP1B and TP2B

Set P1A for 8mv between TP1A and TP2A

BEND Q36A AGAINST HEATSPREADER AWAY FROM MOUNTING NUT.

M1190 V15

SEE LAYOUT DOCUMENTATION

M1610-2

CLINCH ORIGIN

INSERT ORIGIN

Score



SEE LAYOUT DIAGRAM



M1190 V15 PRODUCTION NOTES

1. PCBSA: Apply thermal grease evenly between the large inner and outer heatsinks.
2. PCBSA: Use three 8829 screws to align and attach the large heatsinks to the board.
3. PCBSA: When assembling heatsinks to Q20A, Q20B, Q21A, Q21B and Q37, ensure heatsinks are straight and sitting flat against board. Add a very small amount of RTV between heatsink and board if necessary. This prevents the heatsink from shorting to other components.
4. PCBSA: Fill the open space around Q36B, Q7B, Q7A, Q36A with thermal grease after wave soldering.
5. PCBSA: Bend Q36A against heatspreader AWAY from the adjacent mounting nut.
6. PCBSA: Inspect tabs after solder wave and retouch if necessary for a solid solder joint. Advise PENG if soldering quality of the tabs is poor or not consistent.

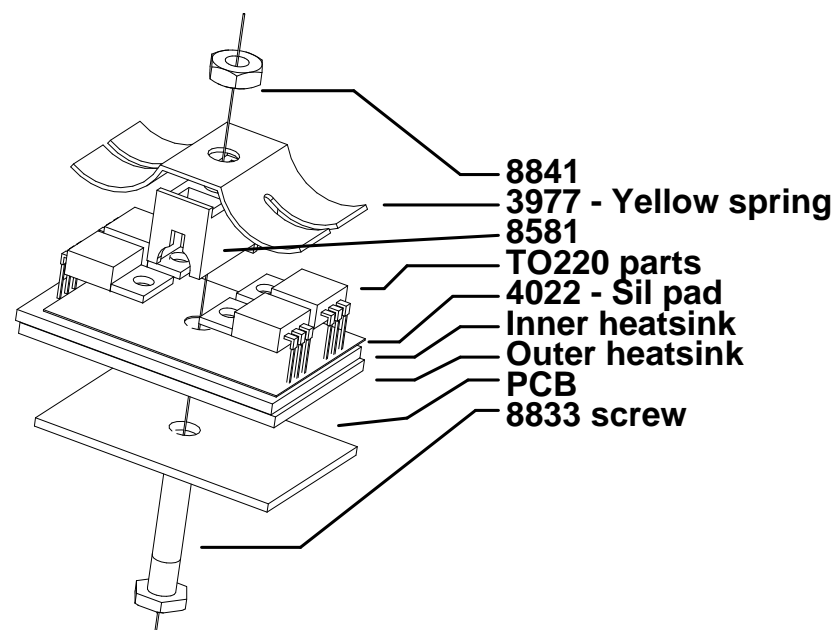
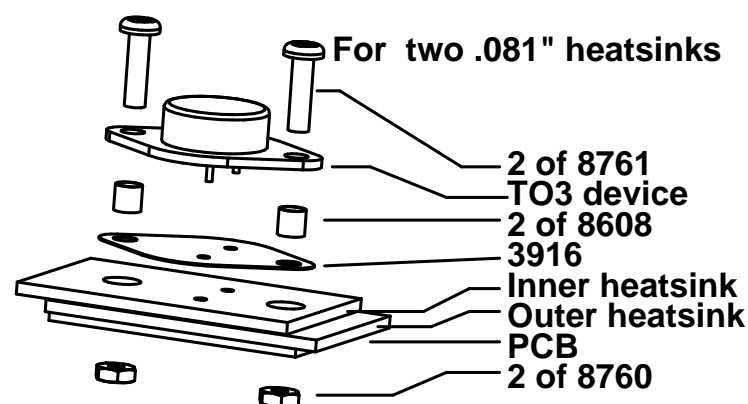

SEE LAYOUT HISTORY

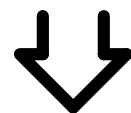





SEE PPRODUCTION NOTES

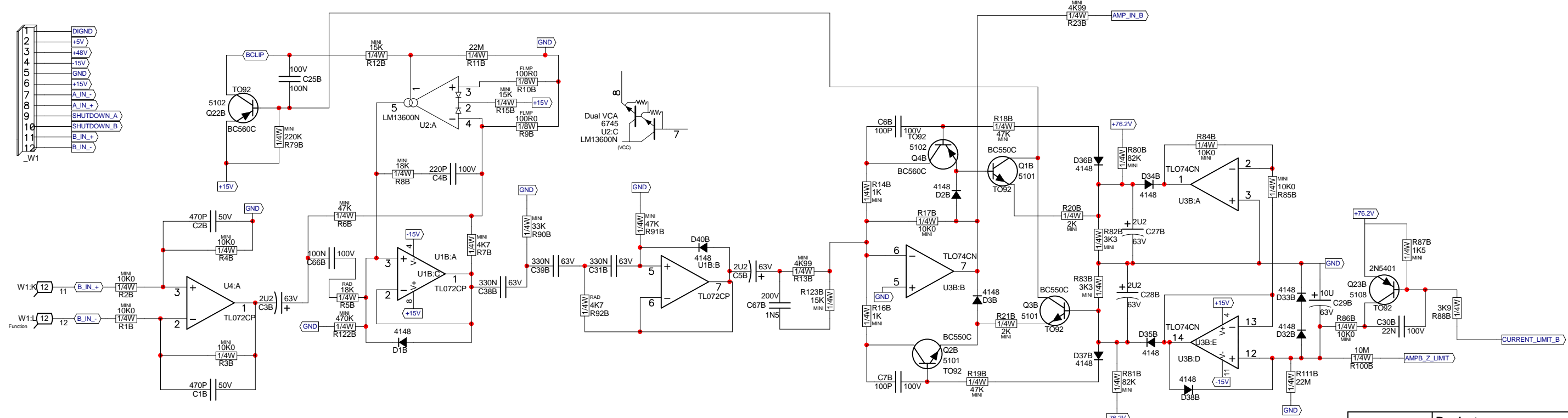
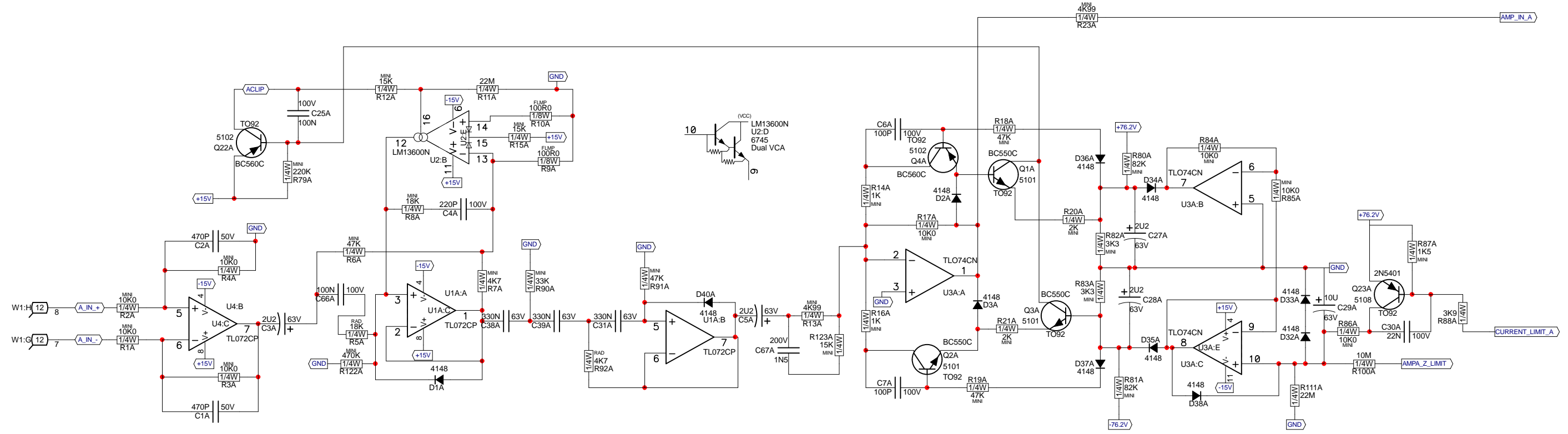

M1190.PCB_DATABASE_HISTORY				#	DATE	VER#	DESCRIPTION OF CHANGE
MODEL(S):-M1610				24	.	.	R79A&B #6127 470K->#6127 220K
				25	.	.	ADDED D4 #5124 5V1/5W, R97&R98 #2006 1R/1W->#5124
				26	.	.	Corrected the position of some test nodes.
				27	.	.	Fixed BlankSize field
#	DATE	VER#	DESCRIPTION OF CHANGE	28	Jun-15-2006	7.00	AH, PC#7021, SPACE BETWEEN R96 AND R53
1	7 Jan, 2004	1.00	Rationalize wire refdes	29	.	.	PC#6983, WIDEN TRACE BETWEEN C32 AND C37
2	24 Feb, 2004	1.00	Add speakon jacks to output section	30	.	.	PC#7091, ENLARGE HOLE SIZE FOR #3522
3	10 Mar, 2004	1.00	Enlarge cutouts for 8841 nuts	31	2008/04/25	8.00	Swap c37 with c51; c57 with c36. Moved x11b & x31b to
4	21-APR-2004	1.00	PC#6681 Modify route to let grn wire pass board near pwr caps	32	.	.	middle of HS slots. Solder updates, part updates.
5	6-MAY-2004	2.00	PC#6684 R83(A,B)->5K6,R5(A,B)6K8->18K, D16&D17(A,B) 4148->BAT85,R47&R48(A,B)22R1->100R0	33	.	.	Changed Q8a&b from 5107 to 5113 - MPSA42
6			ADDED D71, D72	34	2008/05/29	9.00	PC#7590 - PS hum fix. Moved K1B away from X15B.
7				35	2009/11/09	10.00	PCs 7875, 7876 - Ribbon cable change - XTR screws flipped.
8	DEC-14-2004	3.00	GT:PC#6787: Fixed AC clearance, and W2&W3 tab label	36	03-FEB-2010	.	PC7942,PC7980: Update #4xTO220-MTG GG
9	FEB-07-2005	4.00	PC#6809 Remove D17,D16,D12,D13, R47,R48,R49,R50,C14	37	04-FEB-2010	11.00	PC7983: Change D2,D3,D4 #5124 span to .525 GG
10	D	V	C15 (All A/B) R45,R46 A/B 36K->43K, D10 16V->12V	38	10-JUN-2010	12.00	PC#7806: Change transistor pattern to prevent solder shorts. PT
11	D	V	D9 A/B 14V->10V0, D8 A/B 12V->8V2. ADD R95 A/B	39	15-MAY-2012	V13	PC8383 - New double sided PCB released. - ML
12	D	V	ADD R96 A/B, R97 A/B, R98 A/B, D71 A/B, D72 A/B	40	15-MAY-2012	.	PC8423 - Changed NTC thermistors to YS#6619. - ML
13	D	V	D73 A/B, D74 A/B, X1 ,X2 ,X3 ,X4 X5 AND X6	41	21-JUN-2012	V14	Fixed BEC LOC short to heatsink. - ML
14	MAR-30-2005	5.00	RECREATED MASK LAYER TO FIX TESTPADS	42	09-DEC-2015	V15	PC#8734 1N4007 DIODES ADDED TO U5 and U6 -MZ
15	MAR-13-2005	5.10	CHANGE IRF3205 #6954 TO IRL2910 #6966	43	D	V	N
16	.	.	PLACE MICA UNDER MIDDLE TIER MOSFETS	44	D	V	N
17	21 Apr, 2005	5.11	Force update parts to fix pad orientation	45	D	V	N
18	JUN-08-2005	6.00	PC#6919:GT:MOVED R95B AVOID HEATSINK COLLISION	46	D	V	N
19	.	.	XFORMER -> CH1302/E, ADDED 2x#4599,SWAPPED W8 &	47	D	V	N
20	.	.	W35,R106A&B #6122 33K->#4868 36K, D56A&B #6440	48	D	V	N
21	.	.	4V7/0.5W->#6484 10V/1W, C32&C33 #5903 12000UF/35V ->	49	D	V	N
22	.	.	#5898 8200UF/50V, C36&C37 #5896 4700UF/80V->#5898	50	D	V	N
23	.	.	C25A&B #5224 47N/100V->#5212 100N/63V				



1	DIGND
2	+5V
3	+48V
4	-15V
5	GND
6	+15V
7	A_IN_-
8	A_IN_+
9	SHUTDOWN_A
10	SHUTDOWN_B
11	B_IN_+
12	B_IN_-



Product M810-2

Ampln	PCB# M1194	Sheet 1 of 5
Date: Wed Feb 10, 2016	Rev: V12	YsType: .
Filename: M1194V12SCH.sch2006		

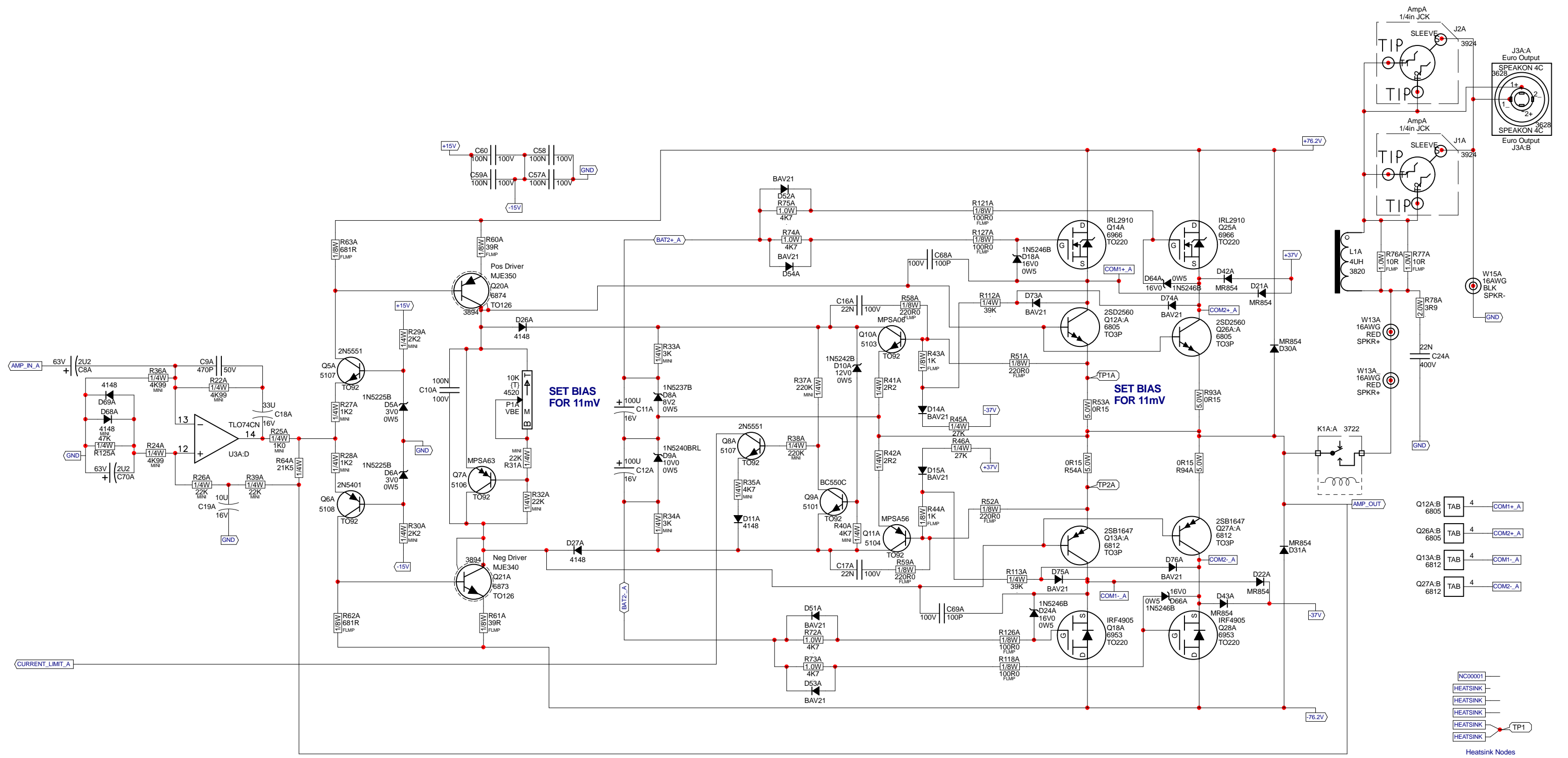

- Q12A:B 6805 TAB 4 COM1+ A
- Q26A:B 6805 TAB 4 COM2+ A
- Q13A:B 6812 TAB 4 COM1- A
- Q27A:B 6812 TAB 4 COM2- A

- NC00001
 - HEATSINK
 - HEATSINK
 - HEATSINK
 - HEATSINK
 - HEATSINK
 - TP1
- Heatsink Nodes



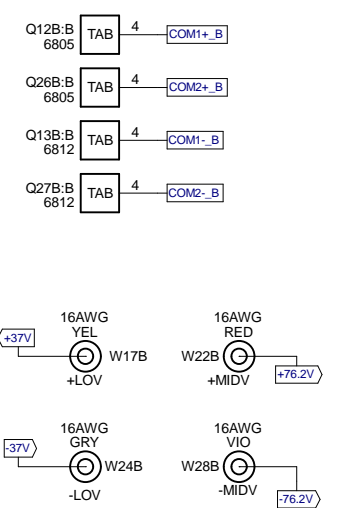
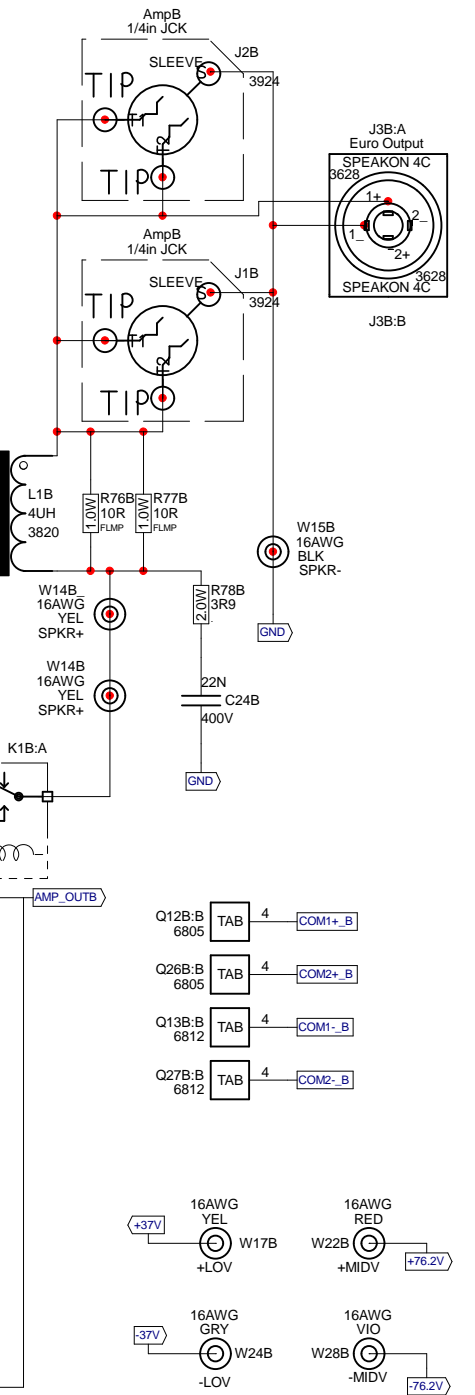
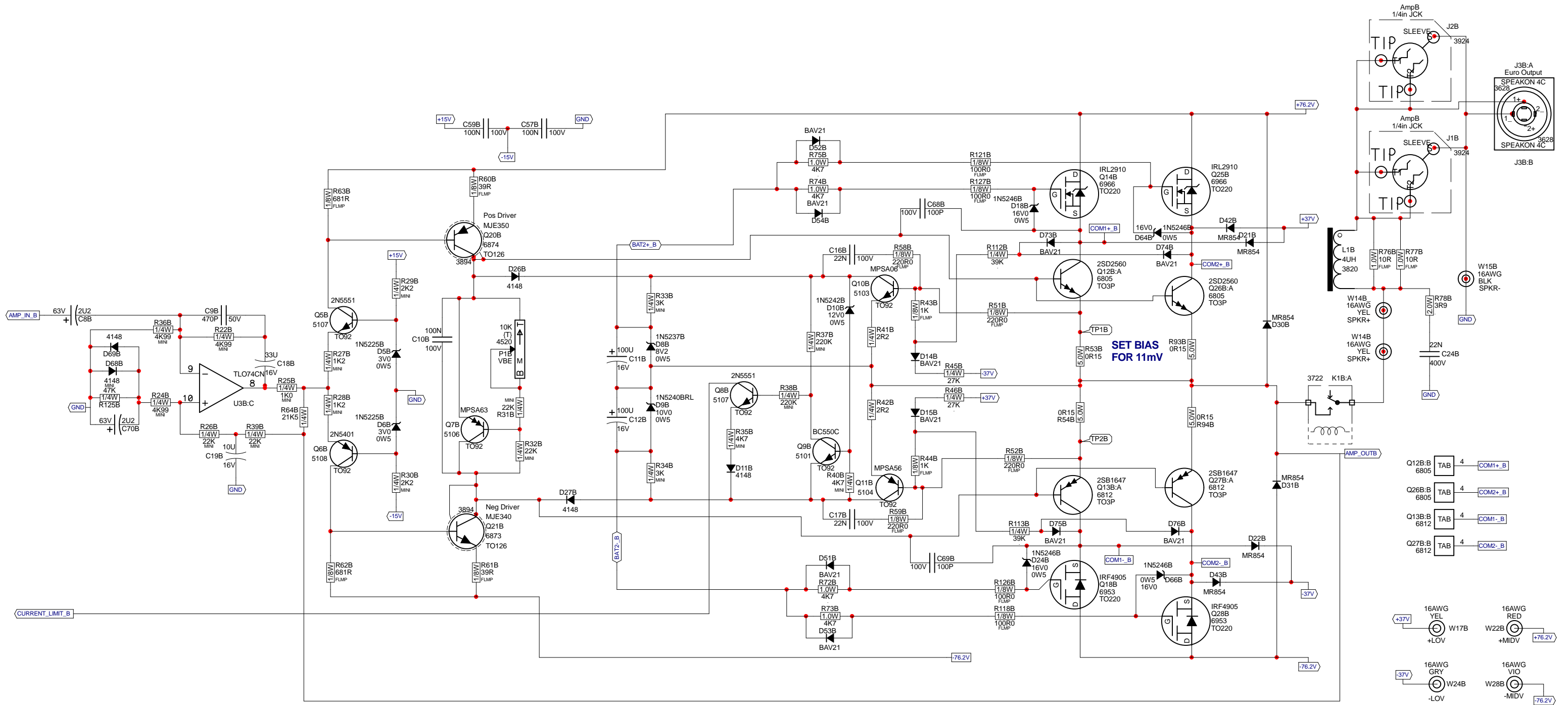

	Product M810-2 Amp B		
	Channel B	PCB# M1194	Sheet 3 of 5
	Date: Wed Feb 10, 2016	Rev: V12	YsType: .
	Filename: M1194V12SCH.2006		

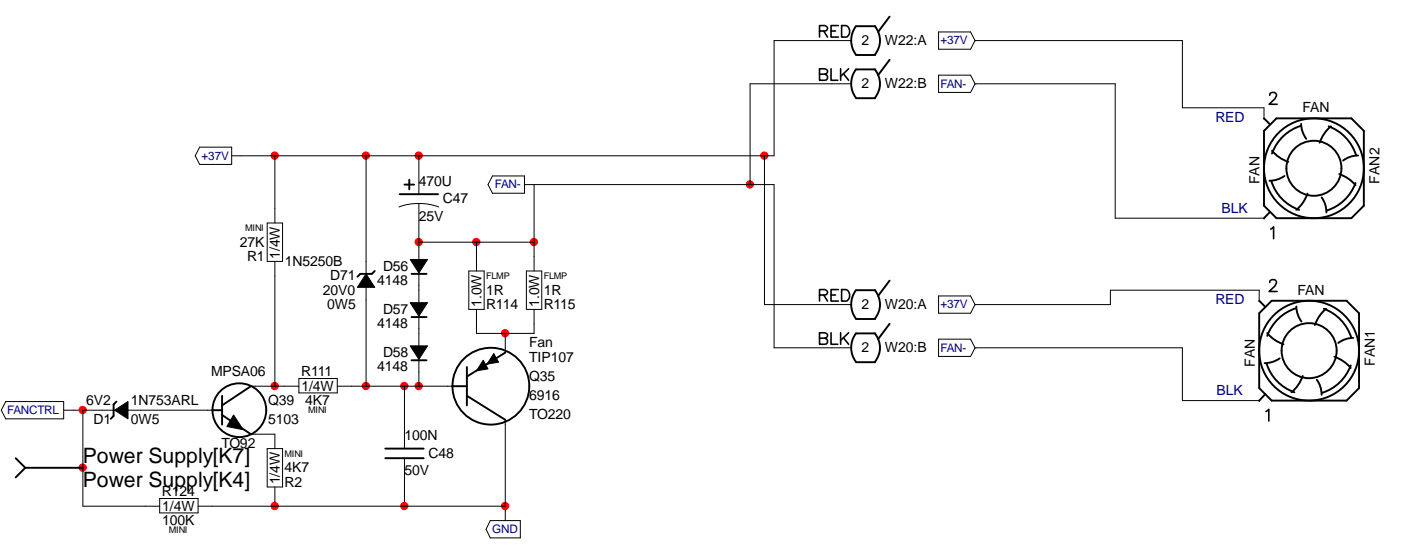

M1194.PCB_DATABASE_HISTORY

#	DATE	VER#	DESCRIPTION OF CHANGE
1	10 Jan, 2004	1.00	Rationalize wire refdes
2	24 Feb, 2004	1.00	Add speakon jacks to output section
3	10 Mar, 2004	1.00	Enlarge cutouts for 8841 nuts
4	1-APR-2004	1.10	PC#6674 Change R31A,B 15k->22k (4979->6118)
5	15-APR-2004	1.20	PC#6678 Chg. R5A,B 6k8->18k; R82A,B 5k6->3k3
6	D	V	R83A,B 56k->3k3; R80A,B, R81A,B 133k->100k
7	21-APR-2004	1.20	PC#6681 Modified route to let grn wire pass near power cap
8	6-MAY-2004	2.00	PC#6685 R80&R81(A,B) 100K->82K, ADDED D71, D72
9	JUN/17/2004	2.10	PC# 6707 Q12 (A+B) Q26 (A+B) TIP142 -> MJH11018
10			Q13 (A+B), Q27 (A+B) TIP147 -> MJH11017
11	13 Sept, 2004	2.11	TC:PC#6763:Moved HS alignment hole to match HS
12	JAN-05-2005	4.00	PC#6808 R72,R73,R74,R75 FROM 10K0 1W TO 4K7 1W
13			D8 A/B 12V0 TO 8V2, D9A/B 14V0 TO 10V0, D10A/B 16V0 TO 12V0.
14			ADD R112A/B, R113A/B (36K), D73A/B, D74A/B
15			D75A/B, D76A/B (BAV21), R45A/B, R46A/B 36K TO 30K
16			REMOVE D16,D17,R47,R48,R49, R50 (ALL A/B)
17			ADD JUMPERS X1 TO X12
18			PC#6794: AC CLEARANCE FIX
19	MAR-24-2005	5.00	FIXED MASK SPREAD TO 30MIL
20	APR-13-2005	5.10	CHANGE IRF3205 #6954 TO IRL2910 #6966
21			PLACE MICA UNDER MIDDLE TIER MOSFETS
22	JUN-29-2005	6.00	PC#6920:GT:R106A/B #6122 33K->#4868 36K, D56A/B
23			#6440 4V7/0W5->#6484 10V1W, C32&C33#5903 12000U/

#	DATE	VER#	DESCRIPTION OF CHANGE
24			35V AND C36&C37#58964700/80V->#5898 8200U/50V
25			UPDATED BIAS NOTE TO READ 11mV, R45A/B&R46A/B
26			#4890 30K->#4833 27K, R112A/B&R113A/B #4868 36K->
27			#4853 39K, C25A/B #5224 47N/100V->#5212 100N/63V,
28			R79A/B #6127 470K->#6126 220K, SWAPPED W8 AND W35
29	19-JUN-2006	7.00	AH, PC#6983, WIDEN TRACE BETWEEN C32 AND C37
30			PC#7091, ENLARGE HOLE SIZE FOR #3522
31	2008/09/23	8.00	Complete force update of pcb. Moved Q7a,b closer to xtrs.
32			Solder updates. Thickened traces to R74, R75. Added
33			NO RTV note to Swatt resistors. Added breaks near caps
34			and jacks - PC#7349. Flipped xtr spring screws
35			- PC#7624 and added fan connector - PC#7628.
36	26-FEB-2008		PC7706, CHANGE #6779 WITH #6805 NPN AND CHANGE
37			#6802 WITH #6812 PNP
38	2009/09/24	9.00	PCs 7875, 7876 - Ribbon cable change - XTR screws flipped.
39	03-FEB-2010		PC7942,PC7980: Update 4xTO220-MTG, 2xTO218-MTG
40	05-FEB-2010	10.00	PC7983: Enlarge D2,D3,D4 span to .525
41	23-MAR-2012	V11	PC8383: CHANGED PCB TO DS / REMOVED EYELETS. - ML
42	03-JUN-2012		PC8423: Replaced thermistors from 6467 to 6619. - ML
43	FEB-8-2016	V12	PC#8734: Two 1N4007 (YS#6438) Diodes added to 15V
44			Supply Regulators..
45	D	V	N
46	D	V	N
47	D	V	N
48	D	V	N
49	D	V	N
50	D	V	N

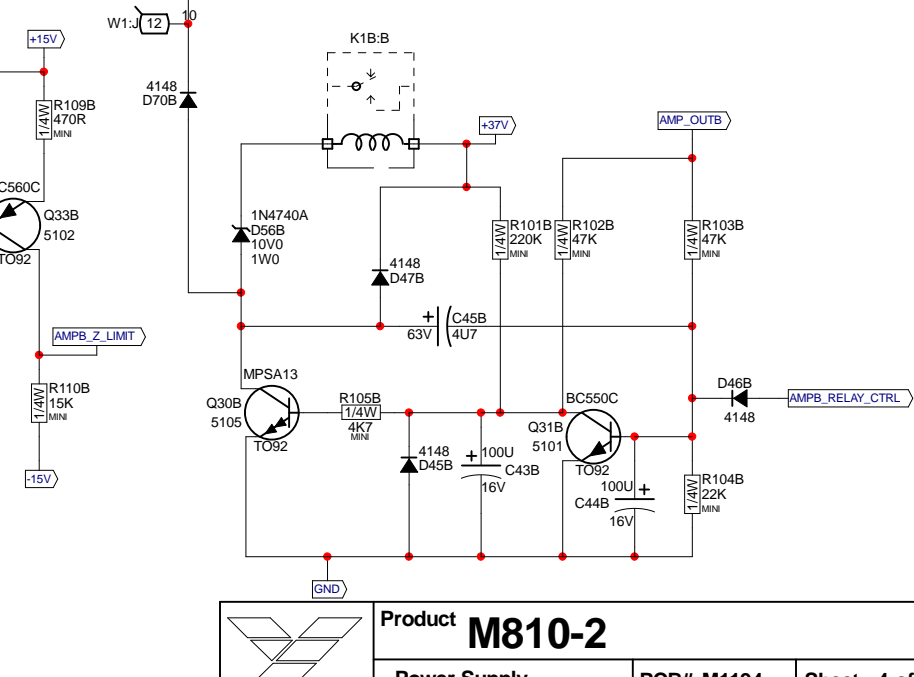
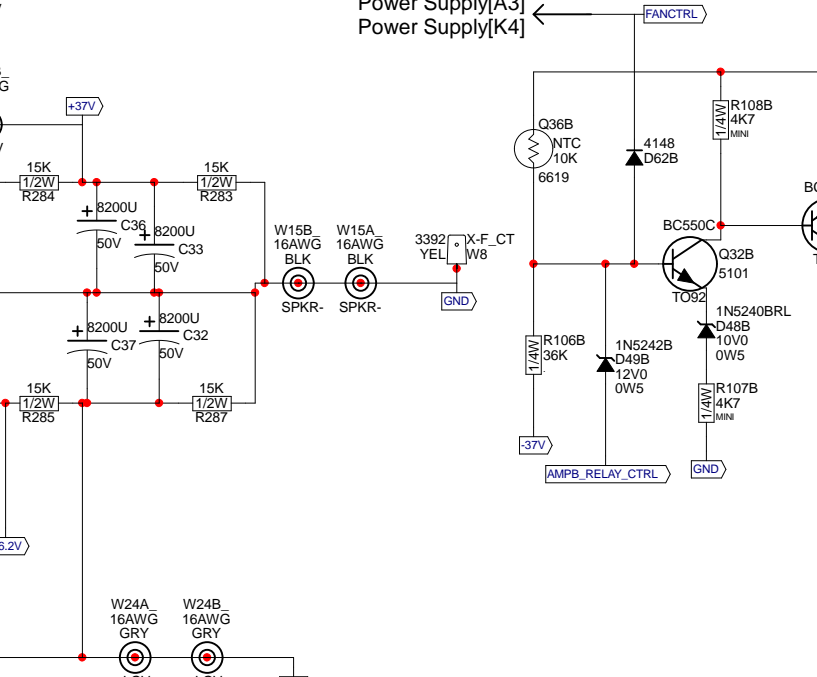
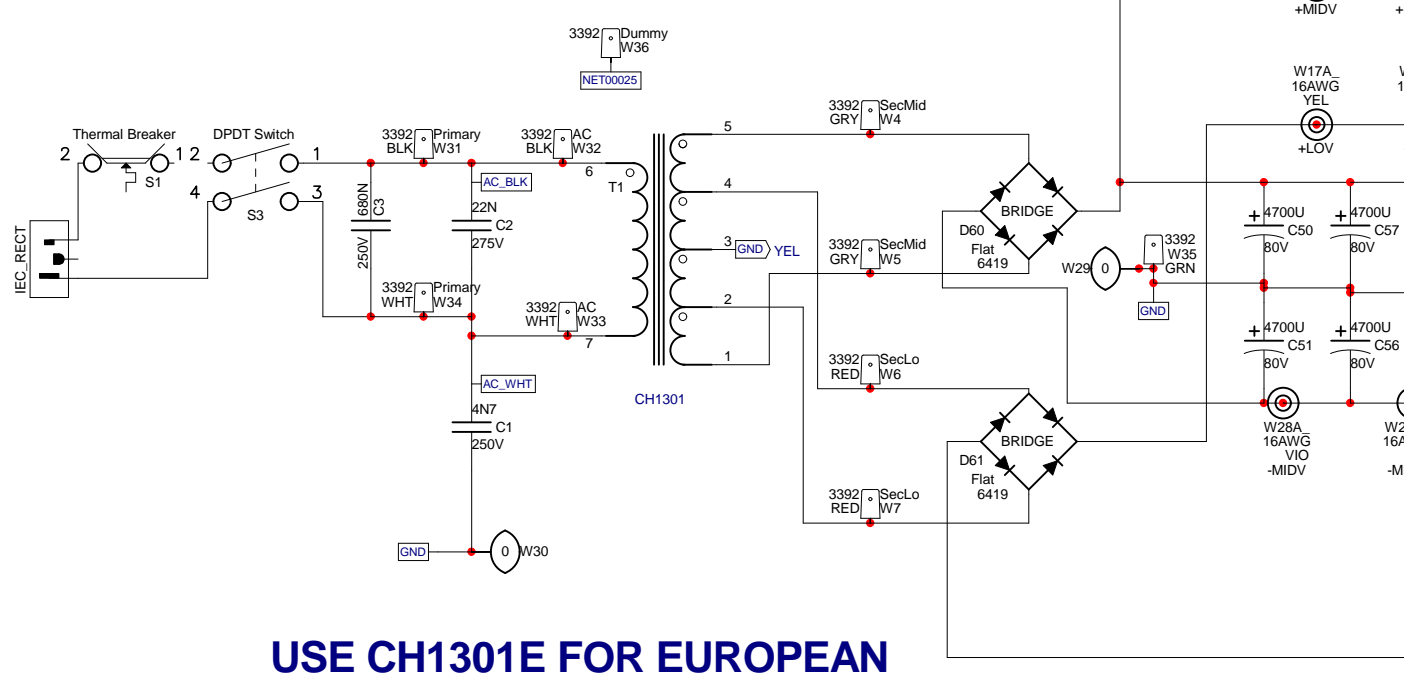
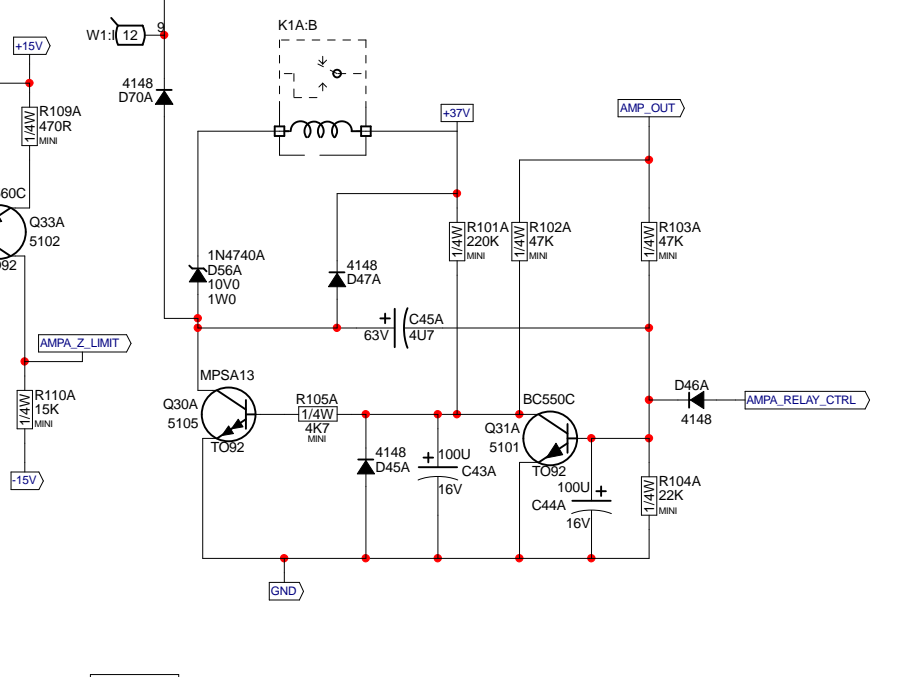
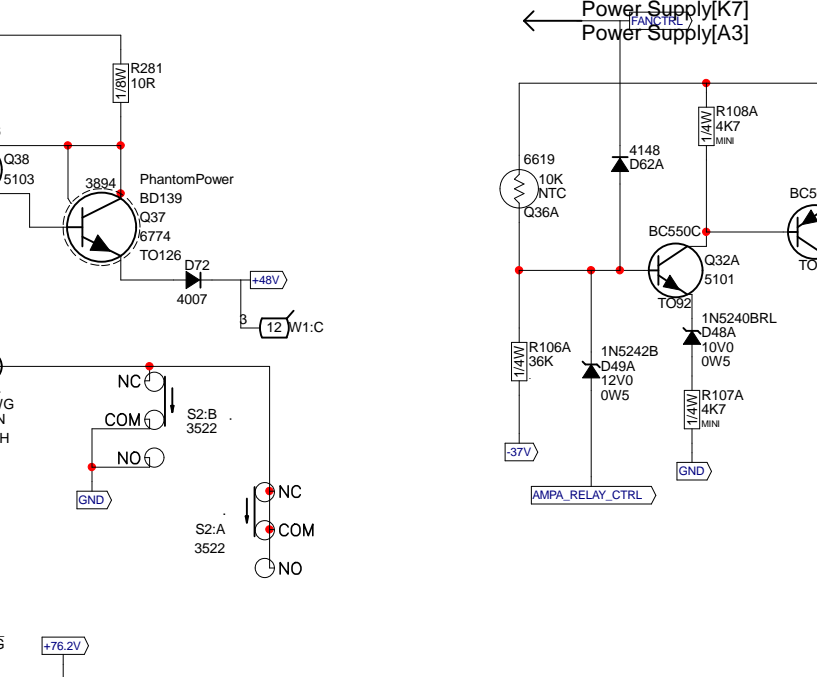
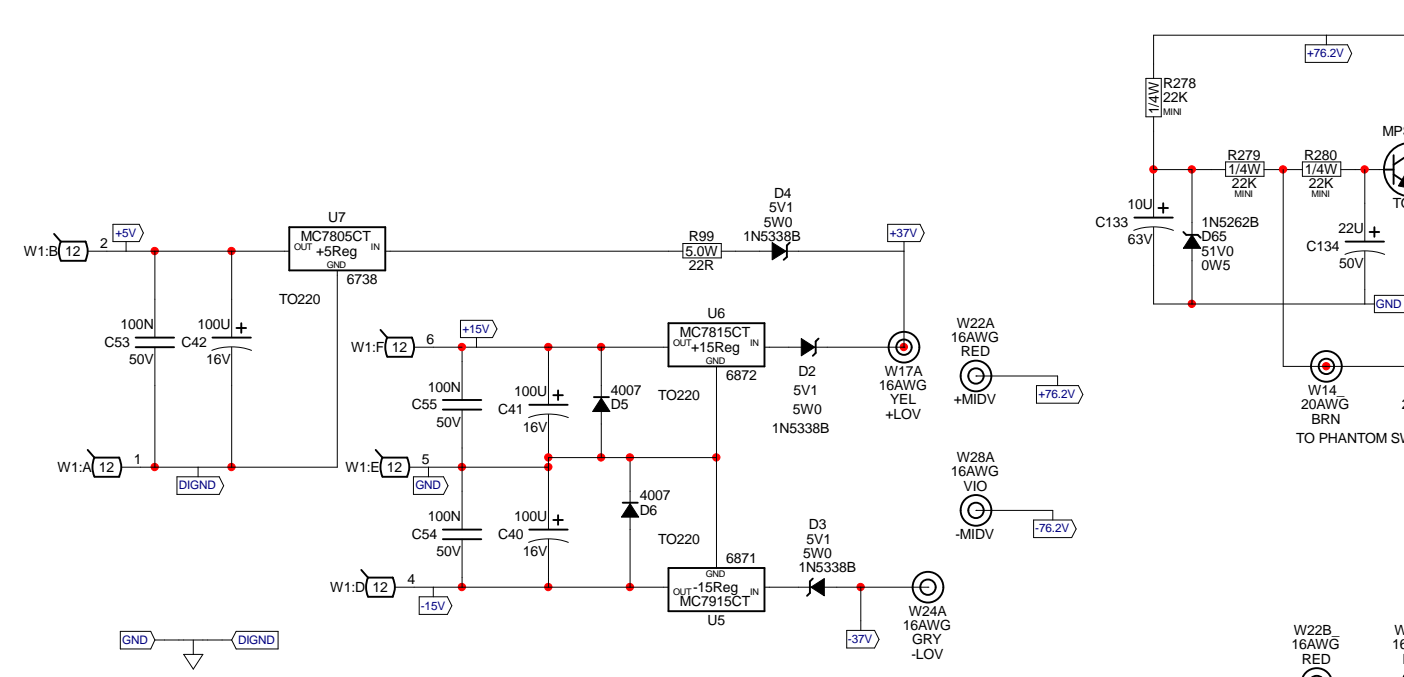

USE CH1301E FOR EUROPEAN

Product M810-2

Power Supply	PCB# M1194	Sheet 4 of 5
Date: Wed Feb 10, 2016	Rev: V12	YsType: .
Filename: M1194V12SCH.sch2006		

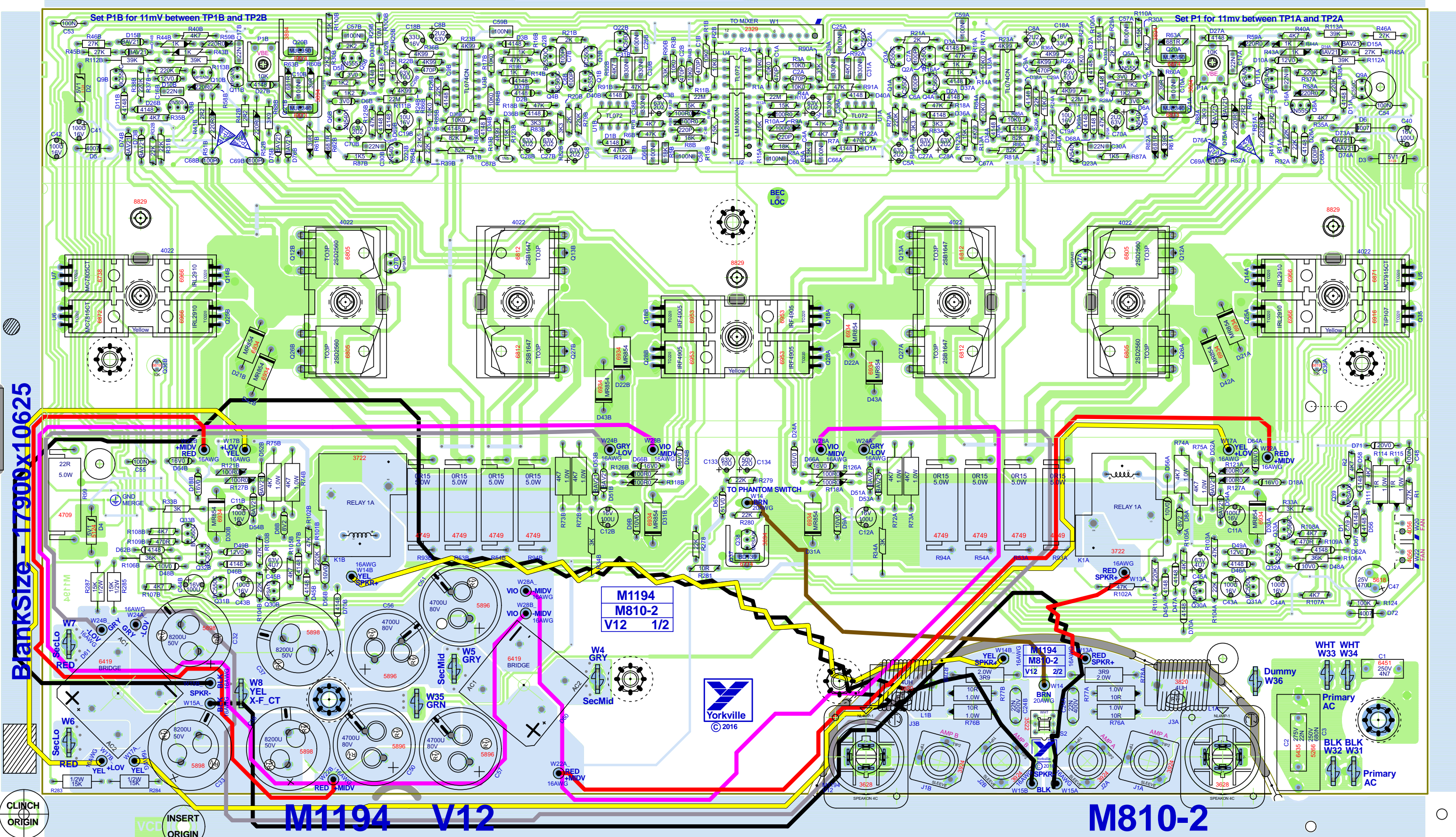

BlankSize - 17900x10625



M1194 V12

M1194 V12

SEE LAYOUT DOCUMENTATION

M810-2

WHT WHT W33 W34

Dummy W36

Primary AC

Primary AC

M1194
M810-2
V12 1/2

M1194
M810-2
V12 2/2



SEE LAYOUT DIAGRAM



M1194 V12

PRODUCTION NOTES

1. PCBSA: Apply thermal grease evenly between the large inner and outer heatsinks.
2. PCBSA: Use three 8829 screws to align and attach the large heatsinks to the board.
3. PCBSA: When assembling heatsinks to Q20A, Q20B, Q21A, Q21B and Q37, ensure heatsinks are straight and sitting flat against board. Add a very small amount of RTV between heatsink and board if necessary. This prevents the heatsink from shorting other components.
4. PCBSA: Fill the open space around Q36B, Q7B, Q7A, Q36A with thermal grease after wave soldering.
5. PCBSA: Inspect tabs after solder wave and retouch if necessary for a solid solder joint. Advise PENG if soldering quality of the tabs is poor or not consistent.

4XTO220-MTG

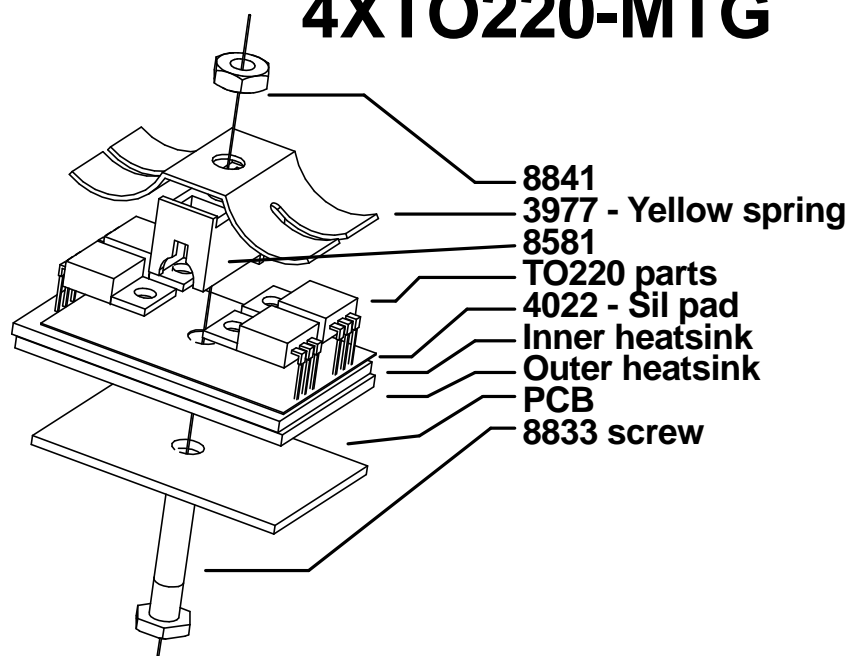

2XTO218-MTG

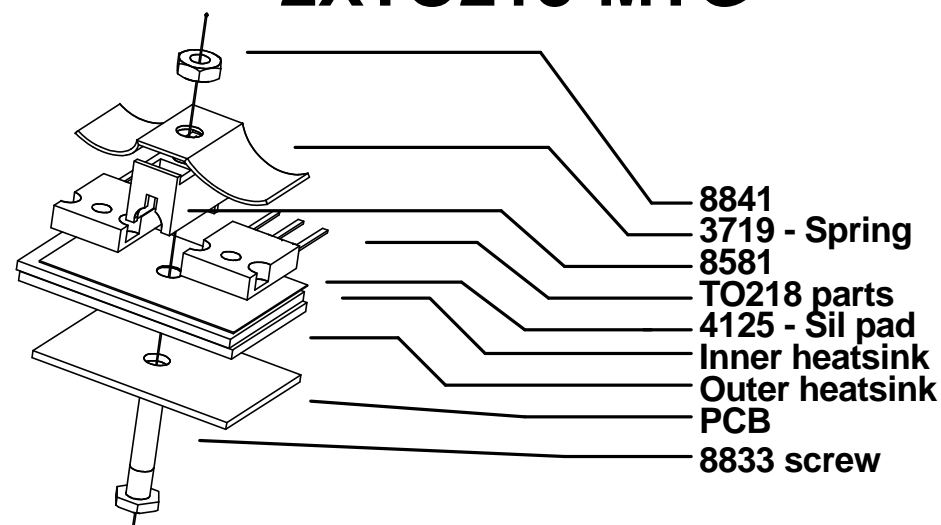

TO126_V_HS_MTG

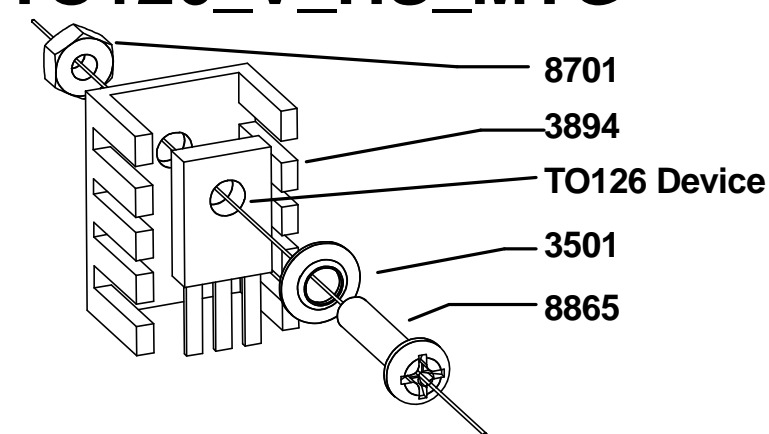



SEE LAYOUT DIAGRAM



M1194.PCB_DATABASE_HISTORY				#	DATE	VER#	DESCRIPTION OF CHANGE
MODEL(S):- M810-2				25	.	.	UPDATED BIAS NOTE TO READ 11mV, R45A/B&R46A/B
#	DATE	VER#	DESCRIPTION OF CHANGE	26	.	.	#4890 30K->#4833 27K, R112A/B&R113A/B #4868 36K->
1	10 Jan, 2004	1.00	Rationalize wire refdes	27	.	.	#4853 39K, C25A/B #5224 47N/100V->#5212 100N/63V,
2	24 Feb, 2004	1.00	Add speakon jacks to output section	28	.	.	R79A/B #6127 470K->#6126 220K, SWAPPED W8 AND W35
3	10 Mar, 2004	1.00	Enlarge cutouts for 8841 nuts	29	19-JUN-2006	7.00	AH, PC#6983, WIDEN TRACE BETWEEN C32 AND C37
4	1-APR-2004	1.10	PC#6674 Change R31A,B 15k-->22k (4979-->6118)	30	.	.	PC#7091, ENLARGE HOLE SIZE FOR #3522
5	15-APR-2004	1.20	PC#6678 Chg. R5A,B 6k8->18k; R82A,B 5k6->3k3	31	2008/09/23	8.00	Complete force update of pcb. Moved Q7a,b closer to xtrs.
6			R83A,B 56k->3k3; R80A,B, R81A,B 133k->100k	32	.	.	Solder updates. Thickened traces to R74, R75. Added
7	21-APR-2004	1.20	PC#6681 Modified route to let grn wire pass near power caps	33	.	.	NO RTV note to 5watt resistors. Added breaks near caps
8	6-MAY-2004	2.00	PC#6685 R80&R81(A,B) 100K->82K, ADDED D71, D72	34	.	.	and jacks - PC##7349. Flipped xtr spring screws
9	JUN/17/2004	2.10	PC# 6707 Q12 (A+B) Q26 (A+B) TIP142 -> MJH11018	35	.	.	- PC#7624 and added fan connector - PC#7628.
10	.	.	Q13 (A+B) , Q27 (A+B) TIP147 -> MJH11017	36	26-FEB-2008	.	PC7706, CHANGE #6779 WITH #6805 NPN AND CHANGE
11	13 Sept, 2004	2.11	TC:PC#6763:Moved HS alignment hole to match HS	37	.	.	#6802 WITH #6812 PNP
12	JAN-05-2005	4.00	PC#6808 R72,R73,R74,R75 FROM 10K0 1W TO 4K7 1W	38	2009/09/24	9.00	PCs 7875, 7876 - Ribbon cable change - XTR screws flipped.
13	.	.	D8 A/B 12V0 TO 8V2, D9A/B 14V0 TO 10V0, D10A/B 16V0 -	39	03-FEB-2010	.	PC7942,PC7980: Update 4xTO220-MTG, 2xTO218-MTG GG
14	.	.	TO 12V0. ADD R112A/B, R113A/B (36K), D73A/B, D74A/B	40	05-FEB-2010	10.00	PC7983: Enlarge D2,D3,D4 span to .550 GG
15	.	.	D75A/B, D76A/B (BAV21). R45A/B, R46A/B 36K TO 30K	41	23-MAR-2012	V11	PC8383: CHANGED PCB TO DS / REMOVED EYELETS. - ML
16	.	.	REMOVE D16,D17,R47,R48,R49, R50 (ALL A/B)	42	03-JUN-2012	.	PC8423: Replaced thermistors from 6467 to 6619. - ML
17	.	.	ADD JUMPERS X1 TO X12	43	FEB-8-2016	V12	PC#8734: Two 1N4007 (YS#6438) Diodes added to 15V
18	.	.	PC#6794: AC CLEARANCE FIX	44	.	.	-Supply Regulators..
19	MAR-24-2005	5.00	FIXED MASK SPREAD TO 30MIL	45	D	V	N
20	APR-13-2005	5.10	CHANGE IRF3205 #6954 TO IRL2910 #6966	46	D	V	N
21	.	.	PLACE MICA UNDER MIDDLE TIER MOSFETS	47	D	V	N
22	JUN-29-2005	6.00	PC#6920:GT:R106A/B #6122 33K->#4868 36K, D56A/B	48	D	V	N
23	.	.	#6440 4V7/0W5->#6484 10V1W, C32&C33#5903 12000U/	49	D	V	N
24	.	.	35V AND C36&C37#58964700/80V->#5898 8200U/50V	50	D	V	N

DRILL & ROUTE HISTORY				M1194 PENDING CHANGES		
MODEL(S):- M810-2				MODEL(S):- M810-2		
#	DATE	VER#	DESCRIPTION OF CHANGE	#	PC#	PENDING CHANGE
1	10-MAR-2004	V02	Enlarged routing for hex nuts	1	PC	X
2	5-MAY-2004	V03	Added notch to routing to pass GRN wire from front	2	PC	X
3	6-MAY-2004	V04	To match v2.00 changes	3	PC	X
4	JAN-05-2005	V05	PC#6763 MOVE TOP LEFT HEATSINK LINE-UP HOLE	4	PC	X
5	20 Apr,2005	5.11	Corrected 'BlankSize' field for clinch program	5	PC	X
6	.	.	Corrected pad orientations on 4520, 5840 and 3722	6	PC	X
7	2008/09/23	13	Solder updates, several PCs. New drill and route.	*PLACE IMPLEMENTED CHANGES INTO BOARD HISTORY		
8	23-MAR-2012	V15	PC8383: PCB converted to double sided.			
9	D	V	N			
10	D	V	N			
11	D	V	N			
12	D	V	N			
13	D	V	N			

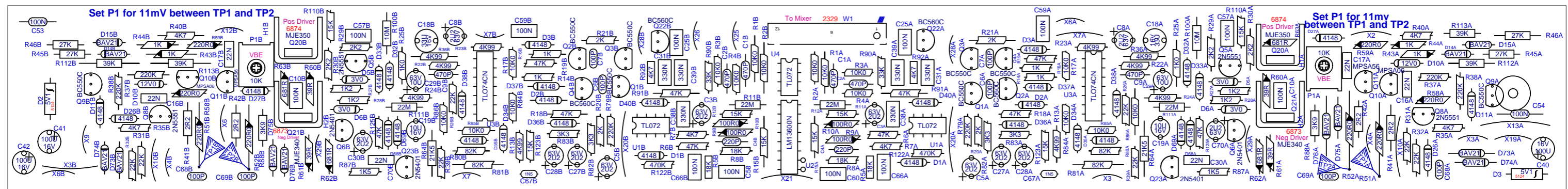

**BEC
LOC**

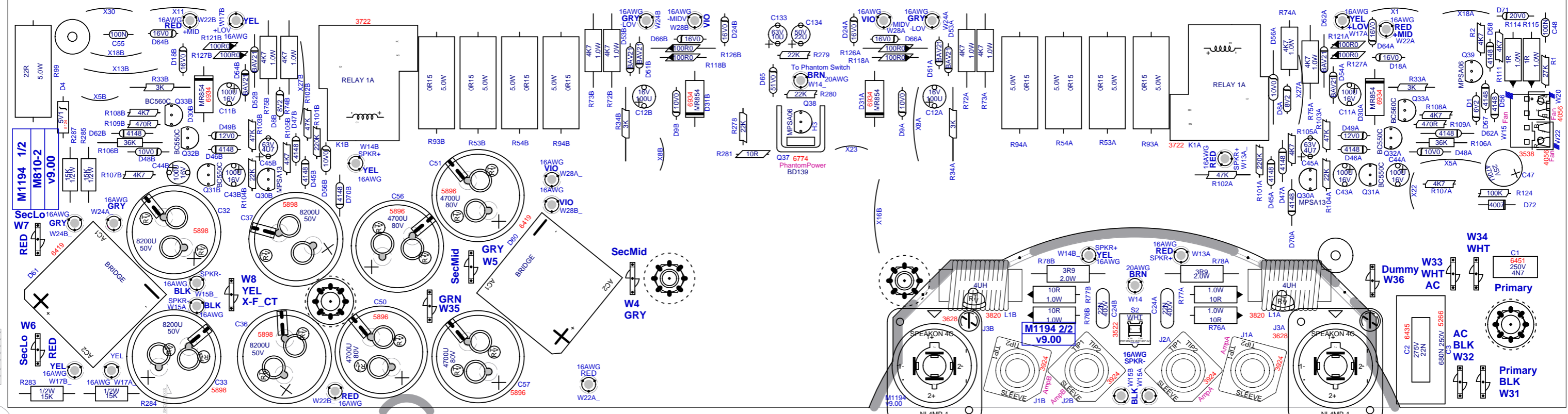
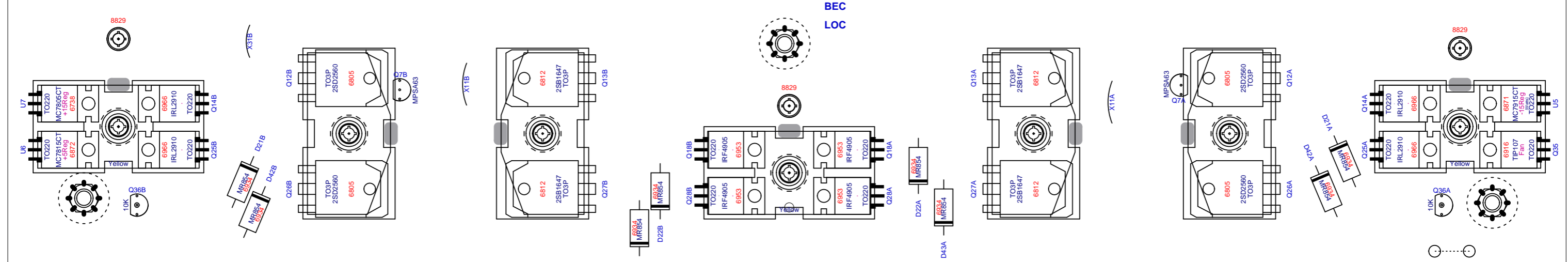



M810/M1610

Series 2



Effect	Modify	Effect	Modify
1. Room Reverb	decay	9. Fast Echo	decay
2. Hall Reverb	decay	10. Short Decay Echo	delay
3. Hall Reverb - Vocals			
4. Hall Reverb w/Echo			
5. Plate Reverb	decay	12. Chorus	rate
6. Plate Reverb - Vocals			
7. Plate Reverb w/Echo			
8. Gated Reverb	decay	14. Rotary Speaker	gain
		15. Distortion	
		16. Harmonizer	pitch

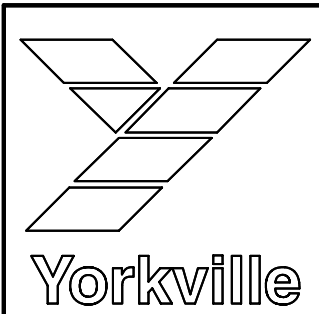
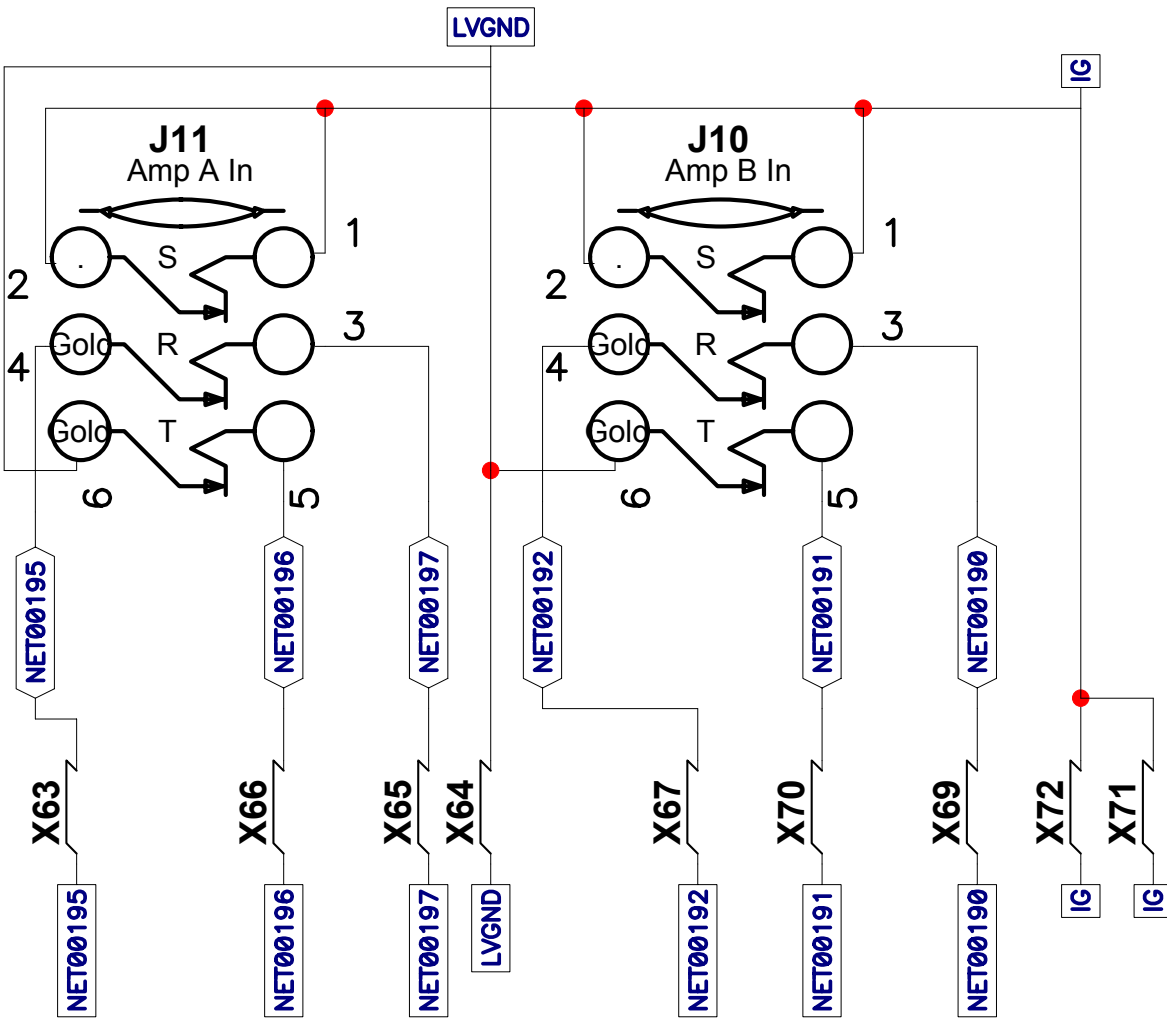

Product M1610		
Amp in Jacks	PCB# M1191	Sheet 1 of 2
Date: Tue Feb 10, 2004		Rev:V1.00
Filename: m1191 sch .sch2002		

StepAndRepeat - X9@1750:Y4@2000
BlankSize = 16.750 x 9.000

SHEAR OFF THIS SIDE SECOND

ETCH GUIDE

BlankSize = 16.750 x 9.000

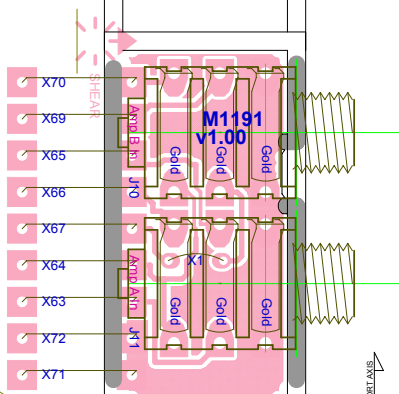

CLINCH ORIGIN

ETCH GUIDE

INSERT ORIGIN

LONG AXIS

Top Assy M1191v1.00

SHEAR OFF THIS SIDE FIRST

FEED THIS SIDE INTO SHEARER FIRST

PRODUCTION NOTES

1. Shear off sides containing VCD origin and VCD finger tabs (top and bottom sides) before shearing the board into rows.
2. Feed board into shearer in the direction shown.
3. DO NOT remove the strip of board attached to each set of jumpers. It will keep the jumpers straight until they arrive in wiring.











Turn Up Trim Control Until Green LED Starts to Blink

STEREO

STEREO

Effect	Modify	Effect	Modify
1. Room Reverb	decay	9. Fast Echo	decay
2. Hall Reverb		10. Short Decay Echo	decay
3. Hall Reverb - Vocals	decay	11. Long Decay Echo	decay
4. Hall Reverb w/Echo		12. Chorus	
5. Plate Reverb		13. Flanger	rate
6. Plate Reverb - Vocals	decay	14. Rotary Speaker	
7. Plate Reverb w/Echo		15. Distortion	gain
8. Gated Reverb	decay	16. Harmonizer	pitch

-  YS#9920 White Knob (qty: 9)
-  YS#9916 Gray Knob (qty: 29)
-  YS#8397 Large Gray Knob (qty: 1)
-  YS#9921 Gray Knob, no cover (qty: 6)
-  YS#9918 Blue Knob (qty: 10)
-  YS#9917 Green Knob (qty: 9)
-  YS#9919 Yellow Knob (qty: 8)
-  YS#9915 Red Knob (qty: 2)

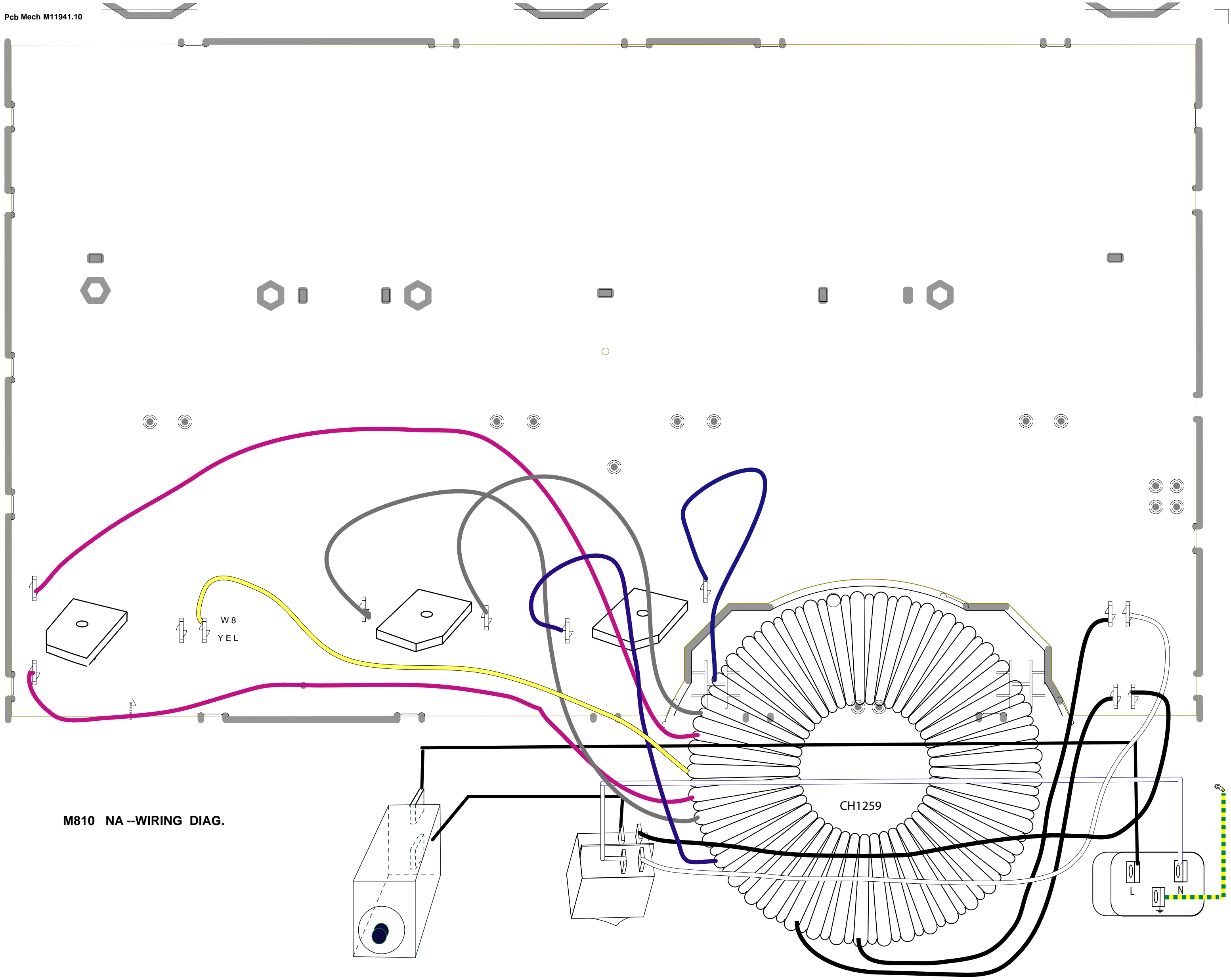

M810 NA --WIRING DIAG.

CH1259

W8
YEL

L
N
GND

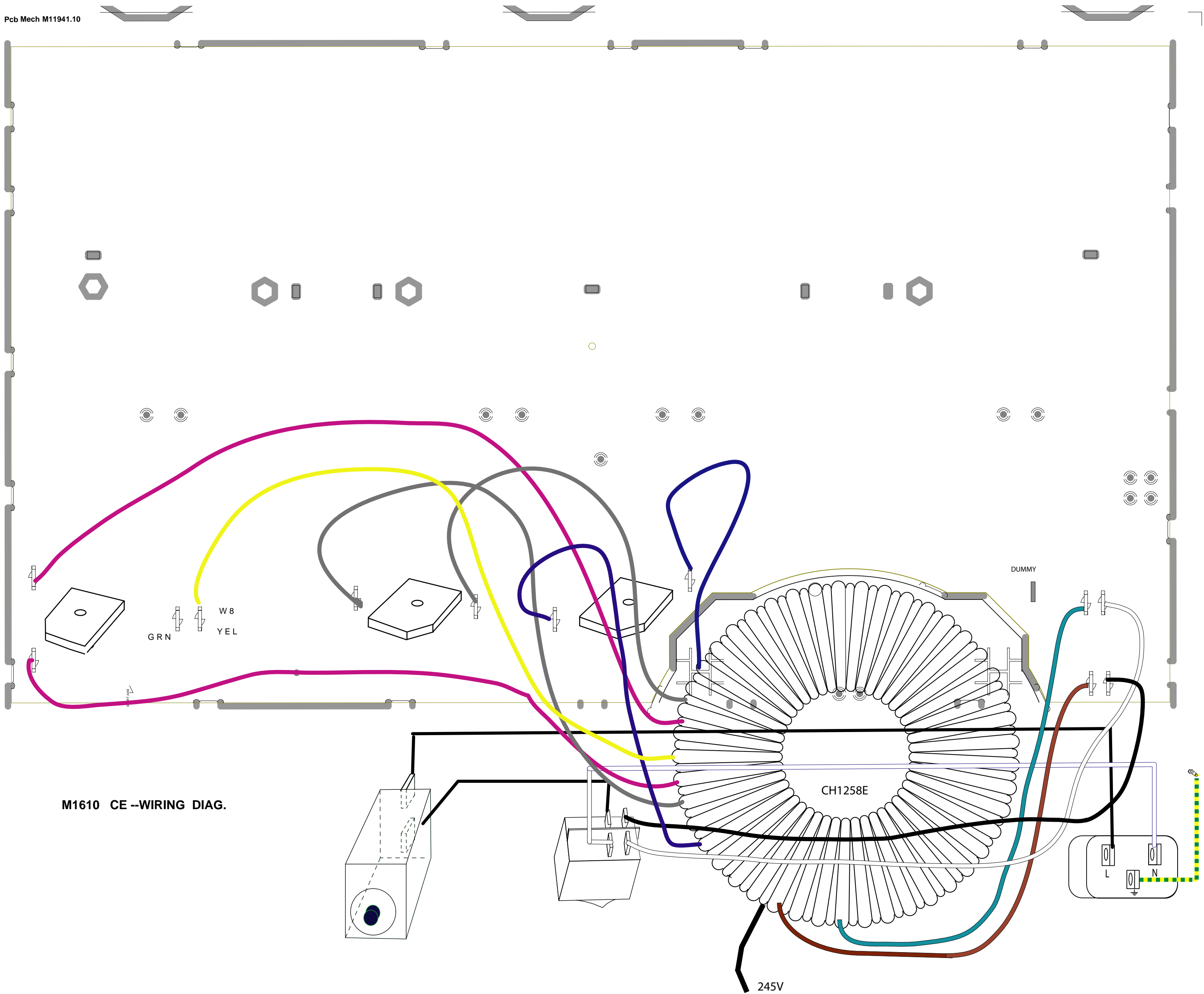

M1610 CE --WIRING DIAG.

CH1258E

DUMMY

GRN
W8
YEL

245V

SHOWN AS 230V OPERATION

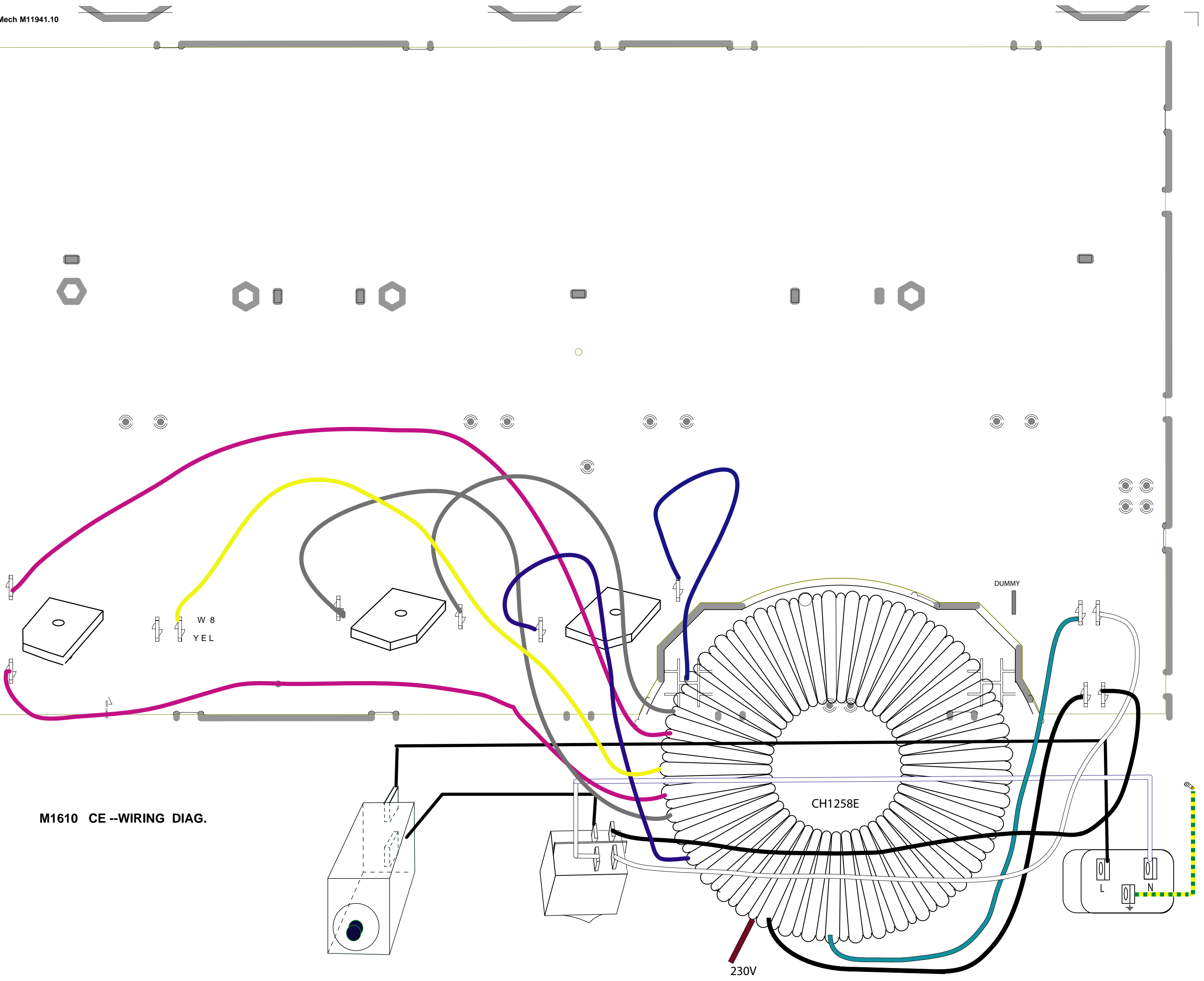

M1610 CE --WIRING DIAG.

SHOWN AS 245V OPERATION
FOR 245V: USE BLUE AND BLACK PRIMARY WIRES