

# TOURNADO™

CSI COB

**IP65**

SUITABLE FOR OUTDOOR USE



Blizzard Lighting, LLC  
[www.blizzardlighting.com](http://www.blizzardlighting.com)  
Waukesha, WI USA  
Copyright (c) 2015

# TABLE OF CONTENTS

TOURNado™ CSI COB	1
<b>1. Getting Started</b>	<b>3</b>
What's In The Box?	3
Getting It Out Of The Box	3
Powering Up!	3
Getting A Hold Of Us	3
Safety Instructions (Don't Stick Your Hand In The Toaster!)	4
<b>2. Meet The TOURNado™ CSI COB</b>	<b>5</b>
Main Features	5
DMX Quick Reference	5
The TOURNado™ CSI COB Pin-up Picture	6
<b>3. Setup</b>	<b>7</b>
Fuse Replacement	7
Connecting A Bunch Of TOURNado™ CSI COB Fixtures	7
Data/DMX Cables	7
Cable Connectors	8
3-Pin??? 5-Pin??? Huh?	8
Take It To The Next Level: Setting up DMX Control	8
Fixture Linking (Master/Slave Mode)	9
Mounting/Rigging	9
<b>4. Operating Adjustments</b>	<b>10</b>
Navigating The Control Panel	10
Control Panel Menu Structure	11
DMX Mode	11
Set The Starting DMX Address	12
Select the DMX Channel Mode	12
Slave Mode	12
Strobe Mode	12
Dimming Mode Settings	13
LED Display and Key Lock Setting	12
DMX Channel Values In-Depth	13
Troubleshooting	13
<b>5. Appendix</b>	<b>14</b>
A Quick DMX Lesson	14
Keeping Your TOURNado™ CSI COB As Good As New	15
Returns (Gasp!)	15
Shipping Issues	15
Tech Specs	16
Dimensional Drawings	17

# 1. GETTING STARTED

## What's In The Box?

- 1 x TOURnado™ CSI COB Professional LED PAR Fixture
- 1 x IP Rated AC power cord with cable cap
- 1 x Set of IP Rated DMX in/out cables
- This Lovely User Manual

## Getting It Out Of The Box

Congratulations aspiring crime fighter and/or psychedelic music aficionado for purchasing the TOURnado™ CSI COB! So now that you've got your new TOURnado™ (or hopefully, *TOURNados!*), you should carefully unpack the box and check the contents to ensure that all parts are present and in good condition. If anything looks as if it has been damaged in transit, notify the shipper immediately and keep the packing material for inspection. Again, please save the carton and all packing materials. If a fixture must be returned to the factory, it is important that the fixture be returned in the original factory box and packing.

## Powering Up!

All fixtures must be powered directly off a switched circuit and **cannot be run off a rheostat (variable resistor) or dimmer circuit, even if the rheostat or dimmer channel is used solely for a 0% to 100% switch.**

*AC Voltage Switch* - Not all fixtures have a voltage select switch, so please verify that the fixture you receive is suitable for your local power supply. See the label on the fixture or refer to the fixture's specifications chart for more information. A fixture's listed current rating is its average current draw under normal conditions. Check the fixture or device carefully to make sure that if a voltage selection switch exists that it is set to the correct line voltage you will use.

**Warning! Verify that the voltage select switch on your unit matches the line voltage applied. Damage to your fixture may result if the line voltage applied does not match the voltage indicated on the voltage selector switch. All fixtures must be connected to circuits with a suitable Ground (Earthing).**

## Getting A Hold Of Us

**If something happens goes wrong, please visit [www.blizzardlighting.com/support](http://www.blizzardlighting.com/support) and open a support ticket. We'll be happy to help, honest.**

**Disclaimer:** The information and specifications contained in this document are subject to change without notice. Blizzard Lighting™ assumes no responsibility or liability for any errors or omissions that may appear in this user manual. Blizzard Lighting™ reserves the right to update the existing document or to create a new document to correct any errors or omissions at any time. You can download the latest version of this document from [www.blizzardlighting.com](http://www.blizzardlighting.com).

Author:	Date:	Last Edited:	Date:
J. Thomas	11/11/2015	J. Thomas	7/25/2016

# SAFETY INSTRUCTIONS



Please read these instructions carefully. They include important information about the installation, usage and maintenance of this product.

- Please keep this User Guide for future use. If you sell the unit to someone else, be sure that they also receive this User Guide.
- ALWAYS make sure that you are connecting to the proper voltage, and that the line voltage you are connecting to is not higher than that stated on the decal or rear panel of the fixture.
- Make sure there are no flammable materials close to the unit while operating.
- The unit must be installed in a location with adequate ventilation, at least 20in (50cm) from adjacent surfaces.
- ALWAYS disconnect from the power source before servicing or replacing fuse and be sure to replace with same fuse size and type.
- ALWAYS secure fixture using a safety chain. NEVER carry the fixture by its cord. Use its carrying handles.
- DO NOT operate at ambient temperatures higher than 104°F (40°C).
- In the event of a serious operating problem, stop using the unit immediately. NEVER try to repair the unit by yourself. Repairs carried out by unskilled people can lead to damage or malfunction. Please contact the nearest authorized technical assistance center. Always use the same type spare parts.
- NEVER connect the device to a dimmer pack.
- Make sure the power cord is never crimped or damaged.
- Never disconnect the power cord by pulling or tugging on the cord.
- Avoid direct eye exposure to the light source while it is on.

**Caution!** There are no user serviceable parts inside the unit. Do not open the housing or attempt any repairs yourself. In the unlikely event your unit may require service, please contact Blizzard Lighting at [www.blizzardlighting.com/support](http://www.blizzardlighting.com/support).

## 2. MEET THE TOURNADO™ CSI COB LED PAR

### MAIN FEATURES

- High output UV light via 1x 100W 390-410nm UV COB LED
- LED control panel with 4x touch sensitive electronic buttons
- Bright light output with 60° beam angle
- Optional control menu button locking feature
- Variable electronic dimming & strobe
- User selectable 32-bit dimming modes plus dimming delay
- Dimmer (1-Ch mode), & Extended with Dimmer, Strobe Effects, & 32-bit dimming (3-Ch) DMX Profiles

### ADDITIONAL FEATURES

- Rugged and well-built (It hits the gym regularly)
- Sturdy cast aluminum housing
- Dual mounting brackets for positioning flexibility
- Flicker-free constant-current 1,500Hz LED driver
- Totally silent convection cooling
- IP Rated AC power cord with cable cap
- IP Rated DMX in/out cables

### DMX Quick Reference - 1/3-Channel Modes

Channel	1-Channel	3-Channel
1	Dimmer	Dimmer
2	---	Strobe
3	---	32-bit Dimming

**Figure 1: The TOURnado™ CSI COB Pin-Up Picture**



**Figure 2: The Rear Connections**

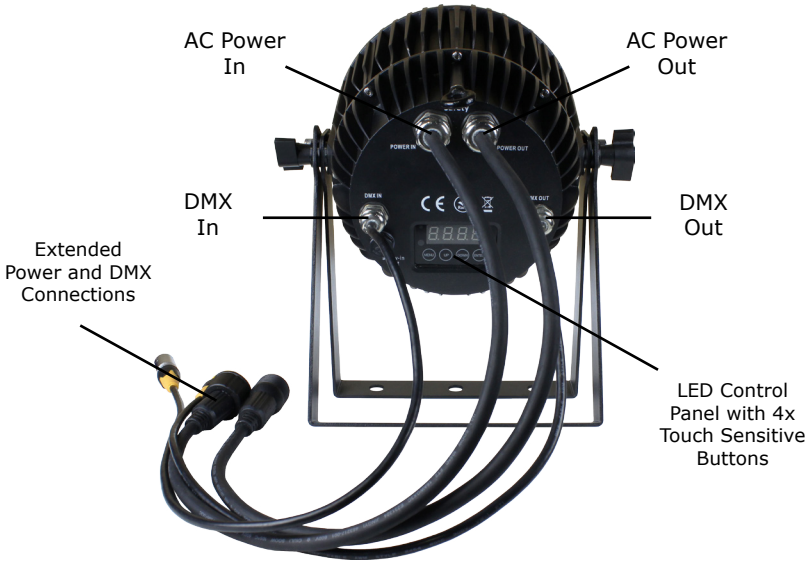

### 3. SETUP



Before replacing a fuse, disconnect power cord. ALWAYS replace with the same type and rating of fuse.

#### Fuse Replacement

**CAUTION!** The TOURnado™ CSI COB utilizes a high-output switch-mode power supply with an internal fuse. Under normal operating conditions, the fuse should not require replacement. The fuse is field replaceable, however it is an advanced procedure suited to qualified individuals. Should your TOURnado™ CSI COB fuse require replacement, please contact Blizzard Lighting for instructions, or to return your unit for service.

#### Connecting A Bunch of TOURnado™ CSI COB Fixtures

You will need a serial data link to run light shows using a DMX-512 controller or to run shows on two or more fixtures set to sync in master/slave operating mode. The combined number of channels required by all the fixtures on a serial data link determines the number of fixtures the data link can support.

Fixtures on a serial data link must be daisy chained in one single line. Also, connecting more than 32 fixtures on one serial data link without the use of a DMX optically-isolated splitter may result in deterioration of the digital DMX signal.

The maximum recommended cable-run distance is 500 meters (1640 ft). The maximum recommended number of fixtures on a serial data link is 32 fixtures.

#### Data/DMX Cabling

To link fixtures together you'll need data cables. You should use data-grade cables that can carry a high quality signal and are less prone to electromagnetic interference.

For instance, Belden© 9841 meets the specifications for EIA RS-485 applications. Standard microphone cables will "probably" be OK, but note that they cannot transmit DMX data as reliably over long distances. In any event, the cable should have the following characteristics:

*2-conductor twisted pair plus a shield  
Maximum capacitance between conductors – 30 pF/ft.  
Maximum capacitance between conductor & shield – 55 pF/ft.  
Maximum resistance of 20 ohms / 1000 ft.  
Nominal impedance 100 – 140 ohms*

## Cable Connectors

Cables must have a male XLR connector on one end and a female XLR connector on the other end. (Duh!)

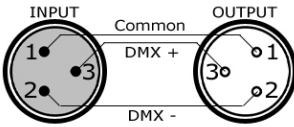

**A Word on Termination:** DMX is a resilient communication protocol, however errors still occasionally occur. Termination reduces signal errors, and therefore best practices include use of a terminator in all circumstances. If you are experiencing problems with erratic fixture behavior, especially over long signal cable runs, a terminator may help improve performance.

**To build your own DMX Terminator:**  
Obtain a 120-ohm, 1/4-watt resistor, and wire it between pins 2 & 3 of the last fixture. They are also readily available from specialty retailers.

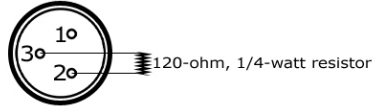

**CAUTION:** Do not allow contact between the common and the fixture's chassis ground. Grounding the common can cause a ground loop, and your fixture may perform erratically. Test cables with an ohm meter to verify correct polarity and to make sure the pins are not grounded or shorted to the shield or each other.

## 3-Pin??? 5-Pin??? Huh?!?

If you use a controller with a 5 pin DMX output connector, you will need to use a 5 pin to 3 pin adapter. They are widely available over the internet and from specialty retailers. If you'd like to build your own, the chart below details a proper cable conversion:

Conductor	3-Pin Female (Output)	5-Pin Male (Input)
Ground/Shield	Pin 1	Pin 1
DMX Data (-)	Pin 2	Pin 2
DMX Data (+)	Pin 3	Pin 3
Not Used.	No Connection.	No Connection.
Not Used.	No Connection.	No Connection.

## Take It To The Next Level: Setting Up DMX Control

**Step 1:** Connect the male connector of the DMX cable to the female connector (output) on the controller.



**Step 2:** Connect the female connector of the DMX cable to the first fixture's male connector (input). *Note:* It doesn't matter which fixture address is the first one connected. We recommend connecting the fixtures in terms of their proximity to the controller, rather than connecting the lowest fixture number first, and so on.

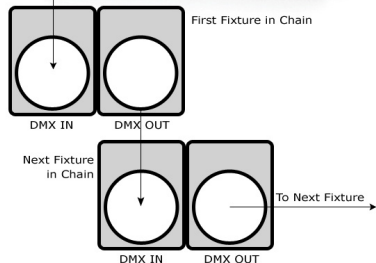

**Step 3:** Connect other fixtures in the chain from output to input as above. Place a DMX terminator on the output of the final fixture to ensure best communication.



## Fixture Linking (Master/Slave Mode)

1. Connect the (male) 3 pin connector side of the DMX cable to the output (female) 3 pin connector of the first fixture.
2. Connect the end of the cable coming from the first fixture which will have a (female) 3 pin connector to the input connector of the next fixture consisting of a (male) 3 pin connector. Then, proceed to connect from the output as stated above to the input of the following fixture and so on.

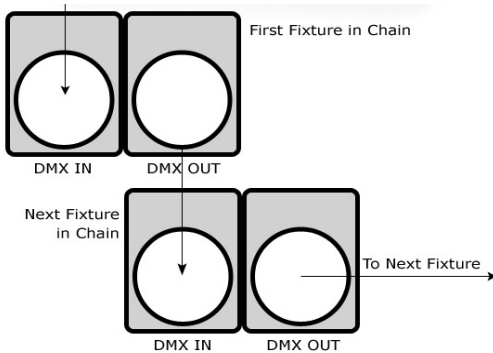

**A quick note:** Often, the setup for Master-Slave and Standalone operation requires that the first fixture in the chain be initialized for this purpose via either settings in the control panel or DIP-switches. Secondly, the fixtures that follow may also require a slave setting.

Check the **“Operating Adjustments”** section in this manual for complete instructions for this type of setup and configuration.

## Mounting & Rigging

This fixture may be mounted in any SAFE position provided there is enough room for ventilation.

It is important never to obstruct the fan or vents pathway. Mount the fixture using a suitable “C” or “O” type clamp. The clamp should be rated to hold at least 10x the fixture’s weight to ensure structural stability. Do not mount to surfaces with unknown strength, and ensure properly “rated” rigging is used when mounting fixtures overhead.

Adjust the angle of the fixture by loosening both knobs and tilting the fixture. After finding the desired position, retighten both knobs.

- When selecting installation location, take into consideration lamp replacement access (if applicable) and routine maintenance.
- Safety cables **MUST ALWAYS** be used.

## 4. OPERATING ADJUSTMENTS

### The Control Panel

All the goodies and different modes possible with the TOURnado™ CSI COB are accessed by using the control panel on the rear of the fixture. There are 4 control buttons below the LED display which allow you to navigate through the various control panel menus.

#### <MENU>

Is used to navigate to the previous higher-level menu item.

#### <UP>

Scrolls through menu items and numbers in ascending order.

#### <DOWN>

Scrolls through menu items and numbers in descending order.

#### <ENTER>

Is used to select and confirm/store the current selection.

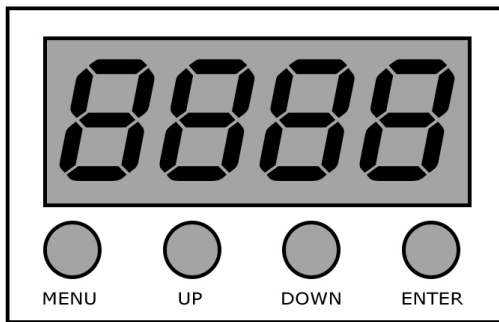

The Control Panel LED Display shows the menu items you select from the menu map on page #11. When a menu function is selected, the display will show immediately the first available option for the selected menu function. To select a menu item, press **<ENTER>**.

Use the **<UP>** and **<DOWN>** buttons to navigate the menu options. Press the **<ENTER>** button to select the menu function currently displayed, or to enable a menu option. To return to the previous option or menu, press the **<MENU>** button.

## Control Panel Menu Structure

<b>ADDR</b>	001-512		To choose the DMX address
<b>STAT</b>	UV		UV intensity (0% <--> 100%)
	SHUT		Flash / strobe speed (0-255)
<b>SET</b>	CHMD	1CH	To run in 1-channel mode
		3CH	To run in 3-channel mode
	DIM (dimming)	LIN	Linear dimming curve
		SQR	Square law curve
		ISQR	Inverse square law curve
		SCUR	S-curve
		LIN.	Linear dimming curve (smooth)
		SQR.	Square law curve (smooth)
		ISQR.	Inverse square law curve (smooth)
		SCUR.	S-curve (smooth)
	DISY	ON	LED menu display is on continually
		ZMIN	LED menu display shuts off after 2 minutes of inactivity
	LOCK	YES	If set to <b>YES</b> , the menu will lock after 2 minutes of inactivity. To unlock, press: <b>&lt;MENU&gt;</b> , <b>&lt;UP&gt;</b> , <b>&lt;DOWN&gt;</b> , <b>&lt;ENTER&gt;</b> , <b>&lt;MENU&gt;</b> , <b>&lt;UP&gt;</b> , <b>&lt;DOWN&gt;</b> , <b>&lt;ENTER&gt;</b> , <b>&lt;MENU&gt;</b> , <b>&lt;UP&gt;</b> , <b>&lt;DOWN&gt;</b> , <b>&lt;ENTER&gt;</b> within 3 seconds between each button press.
NO		Menu lock is off	
<b>INFO</b>	SOFT	Vx.x	Software version information
		POW	Current automated overheat protection level (100%/80%/50%)
<b>LOAD</b>	YES		Restore factory settings
	NO		Cancel

### DMX Mode

Allows the unit to be controlled by any universal DMX controller.

#### Set the Starting DMX Address:

The default mode for the fixture is DMX, so the first menu item that you can edit is the starting DMX address.

- 1.) Navigate the menu using the **<UP/DOWN>** buttons until you reach **Addr**.
- 2.) Push the **<ENTER>** button.
- 3.) Use the **<UP/DOWN>** buttons to select a DMX channel from **001-512**.
- 4.) Press the **<ENTER>** button to confirm.

#### Select the DMX Channel Mode:

- 1.) Navigate the menu using the **<UP/DOWN>** buttons until you reach **CHnd**.
- 2.) Push the **<ENTER>** button.
- 3.) Use the **<UP/DOWN>** buttons to select either **1CH**, or **3CH** mode.
- 4.) Press the **<ENTER>** button to confirm.

#### Slave Mode:

- 1.) Daisy chain the fixtures DMX in/out, having the controller at the beginning of the line.
- 2.) There is nothing else to it! The first fixture in the DMX chain is the master fixture, and the following fixtures will be slave units that follow the master fixture.

#### Strobe Mode:

- 1.) Navigate the menu using the **<UP/DOWN>** buttons until you reach **STAT**.
- 2.) Push the **<ENTER>** button.
- 3.) Use the **<UP/DOWN>** buttons to adjust the flash rate from **000-255**.
- 4.) Press the **<ENTER>** button to confirm.

## Dimming Mode Settings:

Allows users to set the fixture to use 1 of 4 (x2) dimming curve settings for smoother (and slower) dimming capabilities. In the control panel menu, there are two settings for each curve that are distinguishable from one another by the trailing dot.

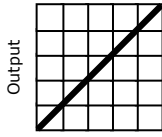

DMX%

### Linear Curve

(LIN, LIN.)

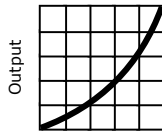

DMX%

### Square Law

(SQR, SQR.)

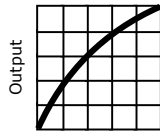

DMX%

### Inverse Square Law

(ISQR, ISQR.)

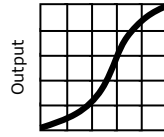

DMX%

### S-Curve

(SCUR, SCUR.)

\*The curve settings with the trailing dot adds a bit more delay to the curve for a smoother effect.

- 1.) Use the **<MENU>** and **<UP/DOWN>** buttons to navigate to **SET** and press **<ENTER>**, then **<UP/DOWN>** buttons again to scroll to **DIM**, and press the **<ENTER>** button.
- 2.) Now use the **<UP/DOWN>** buttons to highlight either **LIN** (Linear), **SQR** (Square), **ISQR** (Inverse Square), **SCUR** (S-Curve), **LIN.** (Smooth Linear), **SQR.** (Smooth Square), **ISQR.** (Smooth Inverse Square), or **SCUR.** (Smooth S-Curve), then hit **<ENTER>**.

## LED Display On/Off:

- 1.) Use the **<MENU>** and **<UP/DOWN>** buttons to navigate to **SET** and press **<ENTER>**, then navigate to **DISY**, and press the **<ENTER>** button.
- 2.) In **DISY**, you can set the LED menu display to be continually on, or shut off after 2 minutes of inactivity.

## LED Display Lock:

- 1.) Use the **<MENU>** and **<UP/DOWN>** buttons to navigate to **SET** and press **<ENTER>**, then navigate to **LOCK**, and press the **<ENTER>** button.
- 2.) Select **YES** or **NO**, and press **<ENTER>** to save. Setting to **YES** will disable the functionality of the buttons after 2 minutes of inactivity. To exit the locked state, press: **<MENU>**, **<UP>**, **<DOWN>**, **<ENTER>**, **<MENU>**, **<UP>**, **<DOWN>**, **<ENTER>**, **<MENU>**, **<UP>**, **<DOWN>**, **<ENTER>** with no longer than 3 seconds between each button press.

## DMX Values In-Depth (3-Channel Mode)

Channel	Value	What It Does
1	000 <--> 255	<b>Dimmer (0% &lt;--&gt; 100%)</b>
2	000 <--> 005 006 <--> 115 116 <--> 130 131 <--> 170 171 <--> 210 211 <--> 250 251 <--> 255	<b>Strobe</b> No Function Normal Strobe (Slow <--> Fast) Random Strobe (Slow <--> Fast) Electronic Sinewave (Slow <--> Fast) Opening pulse (Slow <--> Fast) Closing pulse (Slow <--> Fast) No Function
3	000 <--> 010 011 <--> 020 021 <--> 030 031 <--> 040 041 <--> 050 051 <--> 060 061 <--> 070 071 <--> 080 081 <--> 090 091 <--> 255	<b>32-Bit Dimmer</b> As set in the control menu display Linear curve Square law curve Inverse square law curve S-curve Linear curve and smooth Square law curve and smooth Inverse square law curve and smooth S-curve and smooth Use the dimmer mode which menu had set up

## DMX Values In-Depth (1-Channel Mode)

Channel	Value	What It Does
1	000 <--> 255	<b>Dimmer (0% &lt;--&gt; 100%)</b>

## Troubleshooting

Symptom	Solution
Fixture Auto-Shut Off	Check the fan in the fixture. If it is stopped or moving slower than normal, the unit may have shut itself off due to high heat. This is to protect the fixture from overheating. Clear the fan of obstructions, or return the unit for service.
Beam is Dim	Check optical system and clean excess dust/grime. Also, the overheat protection mode (100%/80%/50% output) could be active. To check, see the LED menu display reading at INFO>SOFT>POW.
No Light Output	Check to ensure fixture is operating under correct mode, IE DMX/Etc., if applicable.
No Power	Check fuse, AC cord and circuit for malfunction.
Fixture Not Responding / Responding Erratically	Make sure all connectors are seated properly and securely. Use Only DMX Cables and/or check cables for defects Install a Terminator. Reset fixture(s).

**If your problem isn't listed, or if problems persist,  
please open a support ticket at [www.blizzardlighting.com/support](http://www.blizzardlighting.com/support).**

# 5. APPENDIX

## A Quick Lesson On DMX

DMX (aka DMX-512) was created in 1986 by the United States Institute for Theatre Technology (USITT) as a standardized method for connecting lighting consoles to lighting dimmer modules. It was revised in 1990 and again in 2000 to allow more flexibility. The Entertainment Services and Technology Association (ESTA) has since assumed control over the DMX512 standard. It has also been approved and recognized for ANSI standard classification.

DMX covers (and is an abbreviation for) Digital MultipleXed signals. It is the most common communications standard used by lighting and related stage equipment.

DMX provides up to 512 control "channels" per data link. Each of these channels was originally intended to control lamp dimmer levels. You can think of it as 512 faders on a lighting console, connected to 512 light bulbs. Each slider's position is sent over the data link as an 8-bit number having a value between 0 and 255. The value 0 corresponds to the light bulb being completely off while 255 corresponds to the light bulb being fully on.

DMX data is transmitted at 250,000 bits per second using the RS-485 transmission standard over two wires. As with microphone cables, a grounded cable shield is used to prevent interference with other signals.

There are five pins on a DMX connector: a wire for ground (cable shield), two wires for "Primary" communication which goes from a DMX source to a DMX receiver, and two wires for a "Secondary" communication which goes from a DMX receiver back to a DMX source. Generally, the "Secondary" channel is not used so data flows only from sources to receivers. Hence, most of us are most familiar with DMX-512 as being employer over typical 3-pin "mic cables," although this does not conform to the defined standard.

DMX is connected using a daisy-chain configuration where the source connects to the input of the first device, the output of the first device connects to the input of the next device, and so on. The standard allows for up to 32 devices on a single DMX link.

Each receiving device typically has a means for setting the "starting channel number" that it will respond to. For example, if two 6-channel fixtures are used, the first fixture might be set to start at channel 1 so it would respond to DMX channels 1 through 6, and the next fixture would be set to start at channel 7 so it would respond to channels 7 through 12.

The greatest strength of the DMX communications protocol is that it is very simple and robust. It involves transmitting a reset condition (indicating the start of a new "packet"), a start code, and up to 512 bytes of data. Data packets are transmitted continuously. As soon as one packet is finished, another can begin with no delay if desired (usually another follows within 1 ms). If nothing is changing (i.e. no lamp levels change) the same data will be sent out over and over again. This is a great feature of DMX -- if for some reason the data is not interpreted the first time around, it will be re-sent shortly.

Not all 512 channels need to be output per packet, and in fact, it is very uncommon to find all 512 used. The fewer channels are used, the higher the "refresh" rate. It is possible to get DMX refreshes at around 1000 times per second if only 24 channels are being transmitted. If all 512 channels are being transmitted, the refresh rate is around 44 times per second.

In summary, since its design and evolution in the 1980's DMX has become the standard for lighting control. It is flexible, robust, and scalable, and its ability to control everything from dimmer packs to moving lights to foggers to lasers makes it an indispensable tool for any lighting designer or lighting performer.

## Keeping Your TOURnado™ CSI COB As Good As New

The fixture you've received is a rugged, tough piece of pro lighting equipment, and as long as you take care of it, it will take care of you. That said, like anything, you'll need to take care of it if you want it to operate as designed. You should absolutely keep the fixture clean, especially if you are using it in an environment with a lot of dust, fog, haze, wild animals, wild teenagers or spilled drinks.

Cleaning the optics routinely with a suitable glass cleaner will greatly improve the quality of light output. Keeping the fans free of dust and debris will keep the fixture running cool and prevent damage from overheating.

In transit, keep the fixtures in cases. You wouldn't throw a prized guitar, drumset, or other piece of expensive gear into a gear trailer without a case, and similarly, you shouldn't even think about doing it with your shiny new light fixtures.

Common sense and taking care of your fixtures will be the single biggest thing you can do to keep them running at peak performance and let you worry about designing a great light show, putting on a great concert, or maximizing your client's satisfaction and "wow factor." That's what it's all about, after all!

### Returns (Gasp!)

We've taken a lot of precautions to make sure you never even have to worry about sending a defective unit back, or sending a unit in for service. But, like any complex piece of equipment designed and built by humans, once in a while, something doesn't go as planned. If you find yourself with a fixture that isn't behaving like a good little fixture should, you'll need to obtain a Return Authorization (RA).

Don't worry, this is easy. Just go to our website and open a support ticket at [www.blizzardlighting.com/tickets](http://www.blizzardlighting.com/tickets), and we'll issue you an RA. Then, you'll need to send the unit to us using a trackable, pre-paid freight method. We suggest using USPS Priority or UPS. Make sure you carefully pack the fixture for transit, and whenever possible, use the original box & packing for shipping.

When returning your fixture for service, be sure to include the following:

- 1.) Your contact information (Name, Address, Phone Number, Email address).
- 2.) The RA# issued to you
- 3.) A brief description of the problem/symptoms.

We will, at our discretion, repair or replace the fixture. Please remember that any shipping damage which occurs in transit to us is the customer's responsibility, so pack it well!

### Shipping Issues

**Damage incurred in shipping is the responsibility of the shipper, and must be reported to the carrier immediately upon receipt of the items. Claims must be made within seven (7) days of receipt.**

## Tech Specs!

<b>Weight &amp; Dimensions</b>	
Width	10.5 inches (26.5 cm)
Depth	7.4 inches (18.7 cm)
Height	8.1 inches (20.5 cm), 11.3 inches (28.6 cm) including bracket height
Weight	8.82 lbs (4 kg)
<b>Power</b>	
Operating Voltage	AC 100V-264V/47-63HZ
Power Consumption	58W, .8A, PF: .63
<b>Light Source</b>	
LED	1x 100W UV COB LED
<b>Optical</b>	
Beam Angle	60 degree
Wavelength	405nm
<b>Thermal</b>	
Max. Operating Temp.	104 degrees F (40 degrees C) ambient
<b>Control</b>	
Protocol	USITT DMX-512
DMX Channels	1 or 3-channels
Input	3-pin XLR Male
Output	3-pin XLR Female
Other Operating Modes	Standalone, Master/Slave, Color Preset
<b>Other Information</b>	
On the bright side, selfie sticks are also lightning rods.	
<b>Warranty</b>	2-year limited warranty, does not cover mal-function caused by damage to LEDs.



# Dimensional Drawings

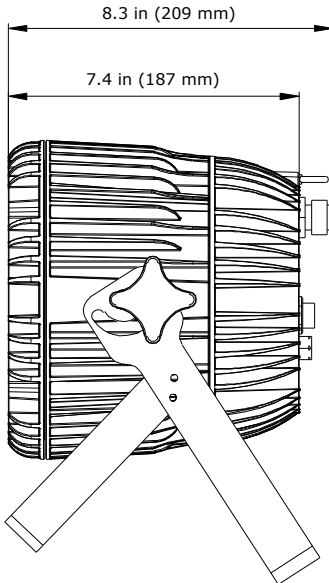
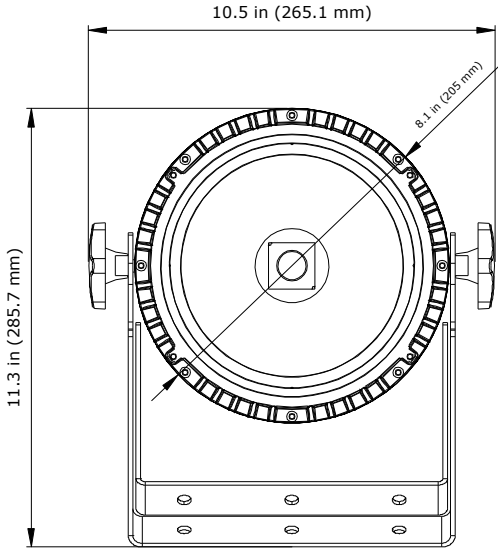

This page intentionally left blank.

This page intentionally left blank.



**Enjoy your product!  
Our sincerest thanks for your purchase!  
--The team @ Blizzard Lighting**