

SoundPlus® Infrared Listening System

Installation Guide and User Manual



TX9 EMITTER

MOD 232 MODULATOR

Contents

System Overview	3
MOD 232 Modulator Setup	4
Determine Location	4
Wiring and Connections	4
Power Connection for U.S. Application	4
For Applications Outside The U.S. Requiring 240 VAC Mains Supply:.....	4
Baseband Cable Connection	5
Audio Connection.....	6
Features and Controls	6
Configuration Settings	7
TX9 Emitter Setup	8
TX9 Location and Placement	8
Coverage Area	9
Multiple Emitters Installed to Maximize Coverage.....	10
Compressor Gain.....	11
TX9 Features and Controls	12
Mounting the TX9.....	12
Receiver Safety Information	13
Recycling Instructions	13
Infrared Receivers	14
Trouble Shooting	15
TX9 Indicator Light Is Not On.	15
Only TX9's Power Indicator LED Comes On.	15
No Sound Through Receivers.	15
Sound Through The Receivers Is Weak And Noisy.	15
Buzzing Or Humming Noise In Sound System.	15
SoundPlus® Infrared Listening System Specifications	16
Two-Channel Modulator, Model MOD 232	16
SoundPlus® Infrared Listening System Specifications	17
Multi-Channel Infrared Emitter, Model TX9.....	17
Limited Warranty	18

System Overview

The Williams Sound SoundPlus® Infrared Listening System consists of a MOD 232 Modulator(s) and one or more TX9 Emitters which use invisible infrared (IR) light to broadcast speech or music to wireless infrared receivers.

The system is designed to transmit high quality audio for hearing assistance and language translation applications. Because the system uses infrared light for transmission, it is not affected by interference from radio equipment and does not interfere with radio equipment. No FCC license or radio approval is required.

The system can be used with microphones as a stand-alone system, or can be connected to other sound equipment. Infrared systems generally cannot be used in direct sunlight because of sunlight's large amount of interfering infrared light.

Note: This equipment has been tested and found to comply with the limits for a Class A digital device, pursuant to part 15 of the FCC Rules. These limits are designed to provide reasonable protection against harmful interference when the equipment is operated in a commercial environment. This equipment generates, uses, and can radiate radio frequency energy and, if not installed and used in accordance with the instruction manual, may cause harmful interference to radio communications. Operation of this equipment in a residential area is likely to cause harmful interference in which case the user will be required to correct the interference at his own expense.

NOTICE: A plasma monitor can degrade the audio quality of the SoundPlus® Infrared Listening System.

MOD 232 Modulator Setup

Determine Location

The modulator is usually located with the sound system amplifier or mixer for easy access to an audio input signal. For portable systems, the modulator can be placed near the emitter or in another convenient location. Infrared Stand Kit SS-6 is available for portable systems.

Wiring and Connections

Figure 1: MOD 232 (Rear View)

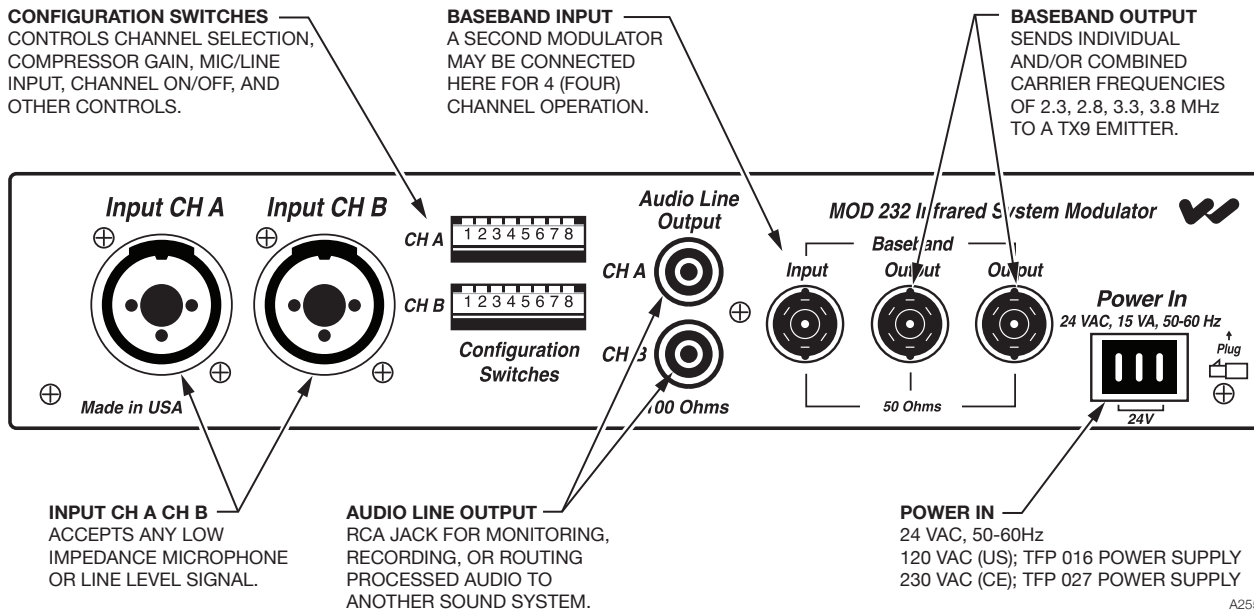

WARNING: POWERLINE VOLTAGE MUST NOT FALL BELOW 94V, OR SYSTEM PERFORMANCE WILL BE GREATLY REDUCED!

Power Connection for U.S. Application

1. Connect the TFP 016 power supply to the 3-pin Molex connector located on the rear of the MOD 232. (See Figure 2, right.)

For Applications Outside The U.S. Requiring 240 VAC Mains Supply:

- Use the transformer power supply, model TFP 027.
Secondary specifications: 24 VAC, 35 VA, 50/60 Hz.
2. Plug the power supply into the AC outlet.

Figure 2: Power Connection

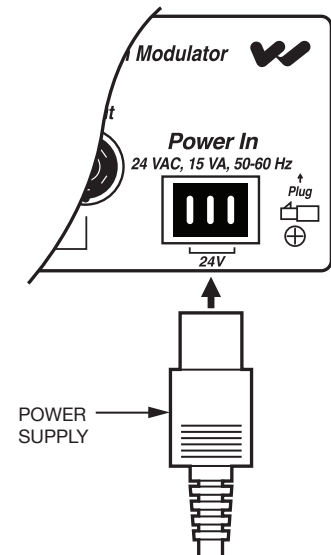

Baseband Cable Connection

The MOD 232 can directly drive one or two emitters. TX9 emitters repeat the baseband signal, so any number of emitters can be used. The modulator outputs CANNOT be split with CATV splitters.

Determine the length of RG-58 cable needed to reach from the TX9 Emitter to the Modulator unit. Install BNC connectors to each end of the cable.

For two-channel operation, only one MOD 232 is required: Connect the coaxial cable to one of the Baseband Output jacks on the rear of the MOD 232. The other end of the coaxial cable connects to the Baseband Input jack of the TX9 Emitter. See Figure 3 below.

Figure 3: Baseband Connection, Two Channel Operation

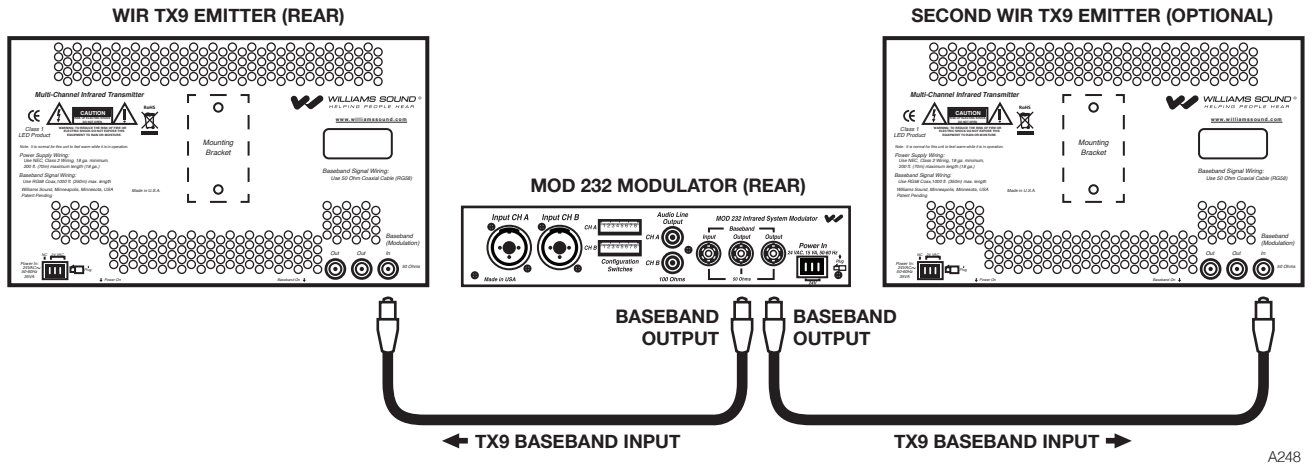

A248

Connect to the TX9 using RG-58 cable and BNC connectors. The MOD 232 has two baseband output jacks to simplify connections when multiple emitters are used.

To setup a system for four-channel operation, two MOD 232 Modulators are required. Link the two Modulator units together as shown in Figure 4. Connect the baseband output from the second modulator in the chain to the TX9 emitter(s) baseband input connector.

Figure 4: Baseband Connection, Four Channel Operation

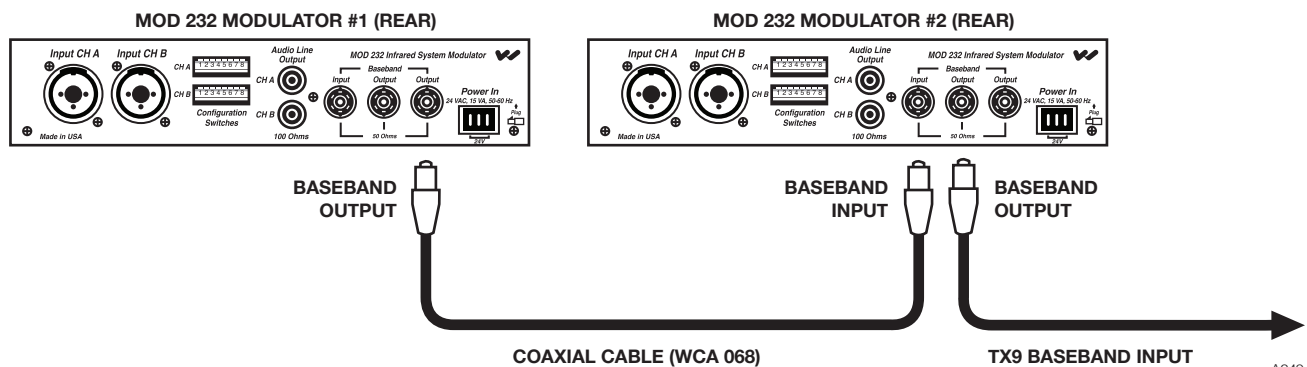

A249

IMPORTANT: Each channel must be set to a different frequency!

Audio Connection

Microphone Input:

With the modulator DIP switches set for microphone input, the 3-pin XLR jack accepts balanced microphones. Power for condenser microphones can be selected by DIP switch. The minimum input level is 100µV and the maximum level is 90 mV.

XLR Line-Level Input:

With the modulator DIP switches set for line-level input, the 3-pin XLR jack accepts balanced line-level audio inputs. The minimum input level is 21mV and the maximum level is 10V.

1/4" TRS Line-Level Input:

The 1/4" Tip/Ring/Sleeve (TRS) jack can accept only a balanced or unbalanced line-level input. A 25 V, 70 V, or 100V speaker line can be connected to the balanced line input using an appropriate attenuator. "T" pads made with resistors yield better fidelity than speaker matching transformers.

Figure 5: Audio Connection

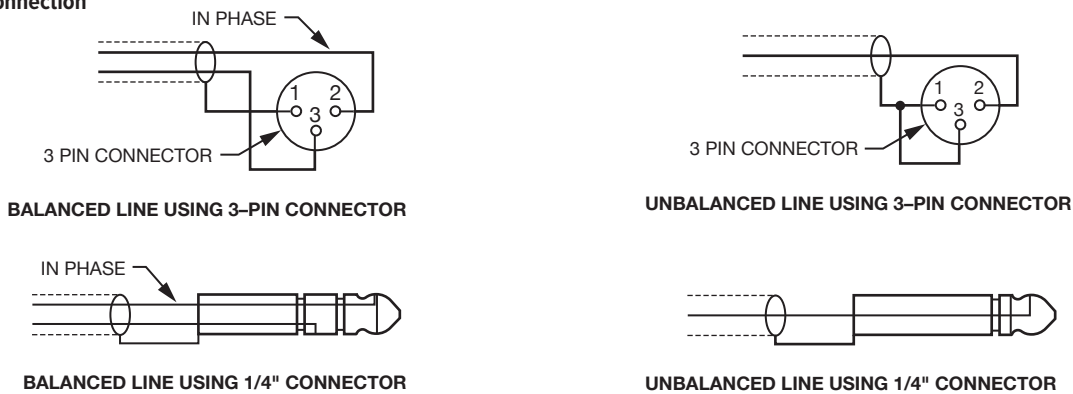

Features and Controls

Figure 6: Features and Controls (MOD 232 Rear)

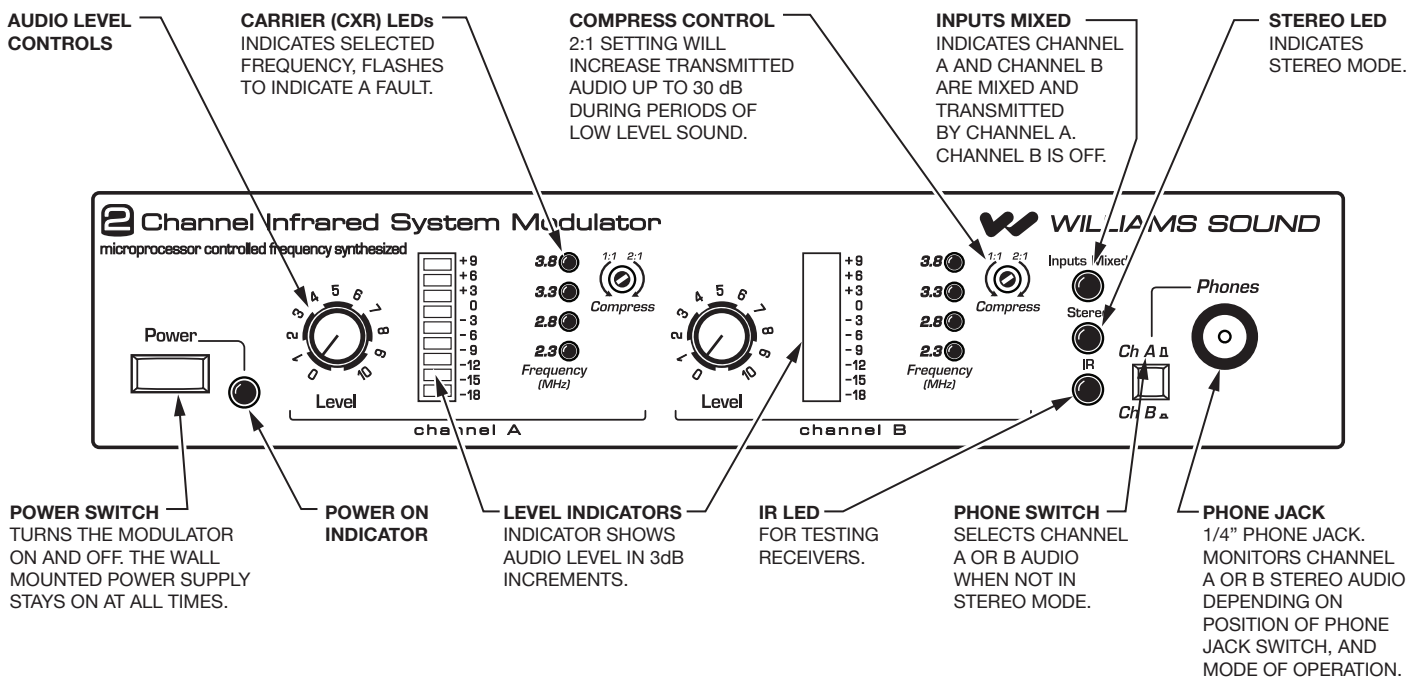

Configuration Settings

Figure 8 illustrates how to configure your system using the DIP switches (Figure 7) located on the back of the MOD 232 Modulator. This diagram is also printed on top of the MOD 232 Modulator unit for quick reference.

Figure 7: Configuration Switches

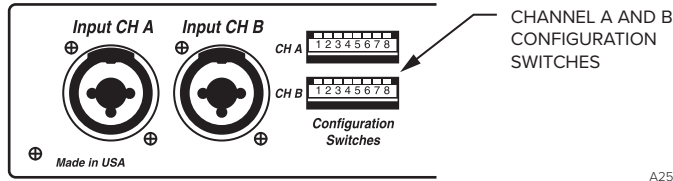

A252

Figure 8: DIP Switch Configuration Chart

IMPORTANT: Channel A and Channel B must be set to different frequencies!

SWITCH SETTINGS	CHANNEL A								CHANNEL B											
	1	2	3	4	5	6	7	8	1	2	3	4	5	6	7	8				
COMPRESSOR GAIN SETS MAXIMUM AVAILABLE COMPRESSOR GAIN	MAXIMUM		↓								↓									
	MODERATE		↑								↑									
MIC/LINE INPUT LINE ALWAYS ON 1/4 INCH MIC OR LINE ON 3 PIN	LINE		↓								↓									
	MIC		↑								↑									
MICROPHONE SIMPLEX POWER 15 VOLTS PER DIN 45596 NOT AVAILABLE IN LINE INPUT MODE	OFF		↓								↓									
	ON		↑								↑									
CARRIER FREQUENCY DO NOT SET BOTH CHANNELS TO THE SAME FREQUENCY	3.800 MHz		↑		↑								↑		↑					
	3.300 MHz		↓		↑								↓		↑					
	2.800 MHz		↑		↓								↑		↓					
	2.300 MHz		↓		↓								↓		↓					
CHANNEL ENABLE TURNS CHANNEL OFF WHEN DISABLED	ENABLED						↓								↓					
	DISABLED						↑								↑					
MIX INPUTS AVAILABLE ONLY IN ONE CHANNEL OPERATION	NOT MIXED						↓								↓					
	MIXED						↑								↑					
2 CHANNEL/STEREO IN STEREO MODE, CHANNEL A COMPRESSION SETTING CONTROLS BOTH CHANNELS	NON-STEREO														↓					
	STEREO														↑					
AUTO SHUT-OFF TIMER TURNS CARRIER(S) OFF AFTER 15 MINUTES OF NO AUDIO	DISABLED						↓								↓					
	ENABLED						↑								↑					

↑ Arrow up indicates *on* position
↓ Arrow down indicates *off* position

SEE MANUAL FOR COMPLETE DESCRIPTION OF CONFIGURATION SETTINGS

A250

Compressor Gain

The MOD 232's Compressor Gain is set in "Moderate" mode from the factory. Use this setting for simultaneous interpretation. Be sure that the compress control, located on the front of the MOD 232 (Figure 6, page 6), is turned fully counter-clockwise. Compression can be added if desired by turning the compress control clockwise.

For hearing assistance applications, the MOD 232's Compressor Gain can be set to "Maximum" mode. For additional compression, use a tuning wand (PLT 005) or small screw driver and gently turn the compress control (Figure 6, page 6) on the front of the MOD 232 clockwise.

TX9 Emitter Setup

TX9 Location and Placement

To determine the best location for the TX9 Emitter, it helps to think of the IR emitter as an invisible floodlight. You'll want to aim it so the listeners are "flooded" with the infrared light. Mount the emitter at least 2 ft (.61 m) above the audience.

Position the emitter to face in a slightly downward angle - that will increase the "throw" of the infrared beam. Infrared light reflects off most surfaces and scatters, increasing the coverage area. Rough surfaces tend to absorb infrared light, minimizing reflections, and limiting coverage to the direct illumination. Remember: opaque objects block infrared light. Thus, emitters cannot be concealed behind opaque walls, curtains, etc.

The emitter front red plastic lens must NOT be painted. Neither should emitters be used in areas of extreme high or low temperature, humidity, or chemical environments.

The TX9 Infrared Emitter should not be installed where there is a lot of direct sunlight, which can create infrared interference.

Figure 9: 3 Dimension Foot Pattern

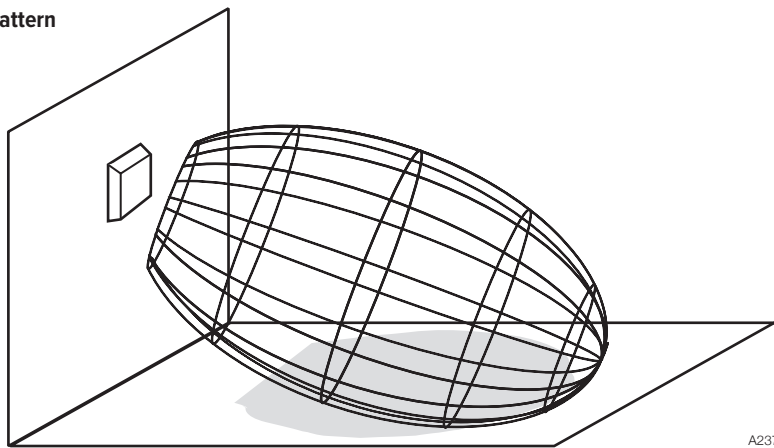
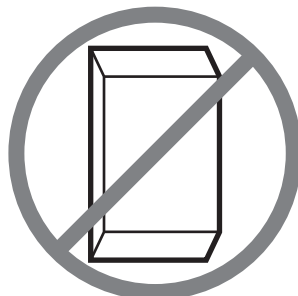

Figure 10: NOTE: When pointing the emitter, be sure to keep the long dimension horizontal.



CORRECT



INCORRECT

Coverage Area

Figure 11: Maximum Range when using the RX22-4, RX15-2, or RX18 receiver

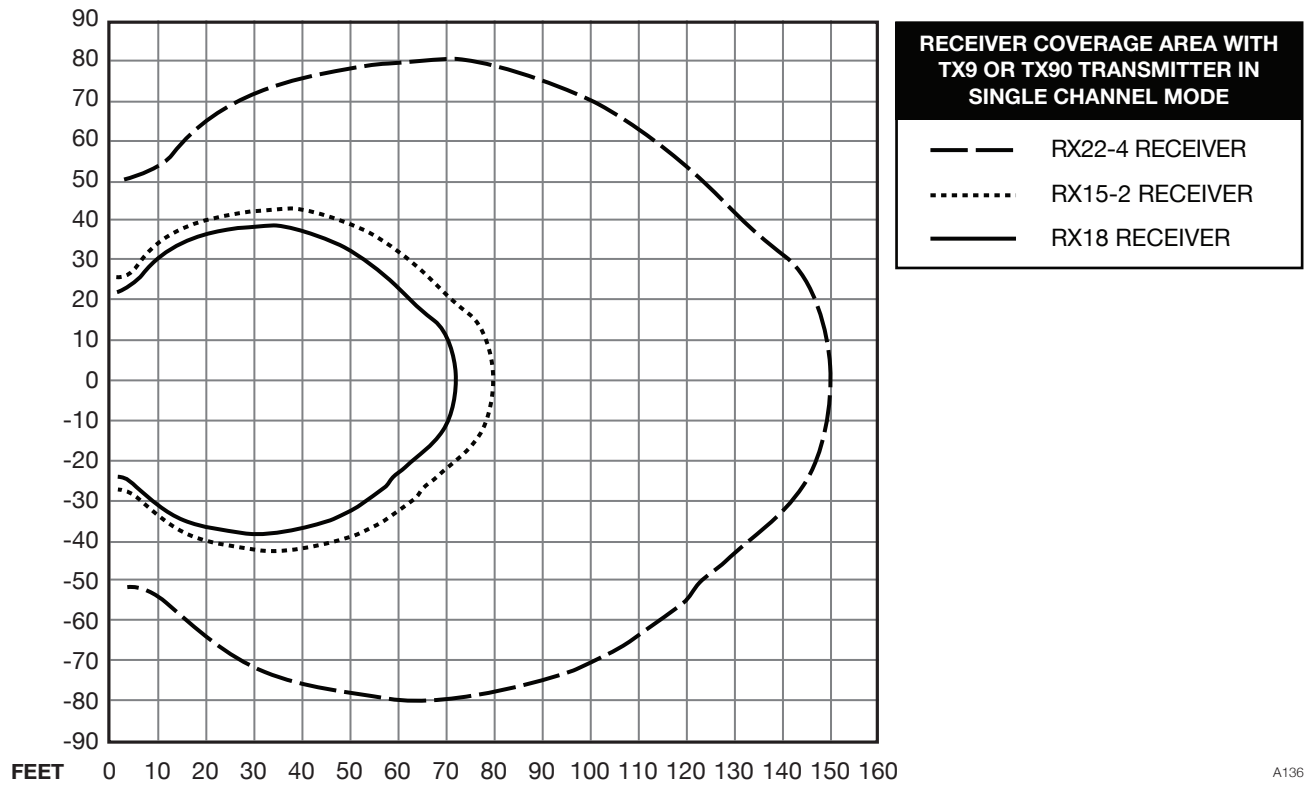

These patterns are the direct radiation pattern. The infrared radiation does not drop to zero outside the illustrated patterns; it decreases. It still may be usable at a greater distance, depending on the receiver sensitivity and the reflective characteristics of the room. Reflections of the infrared light from walls, ceilings, and floors may change these patterns.

Multiple Emitters Installed to Maximize Coverage

Figure 12A

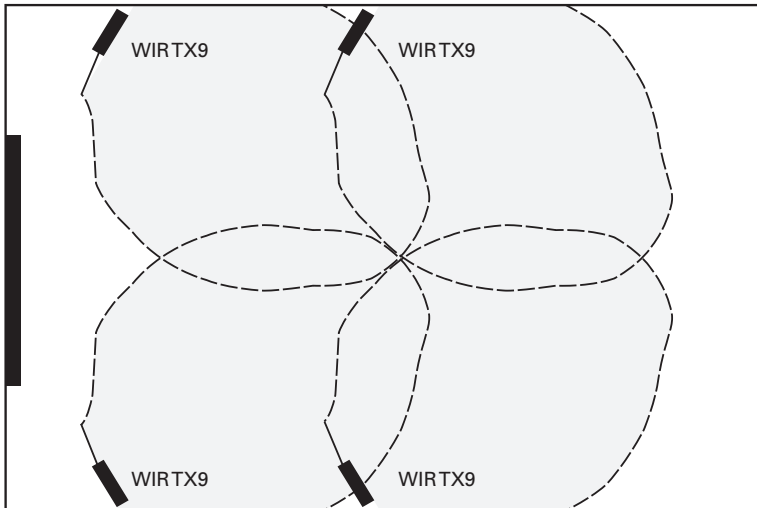

A262

Figure 12A and 12B: Overlapping Illumination Patterns to Cover Larger Listening Areas

Figure 12B

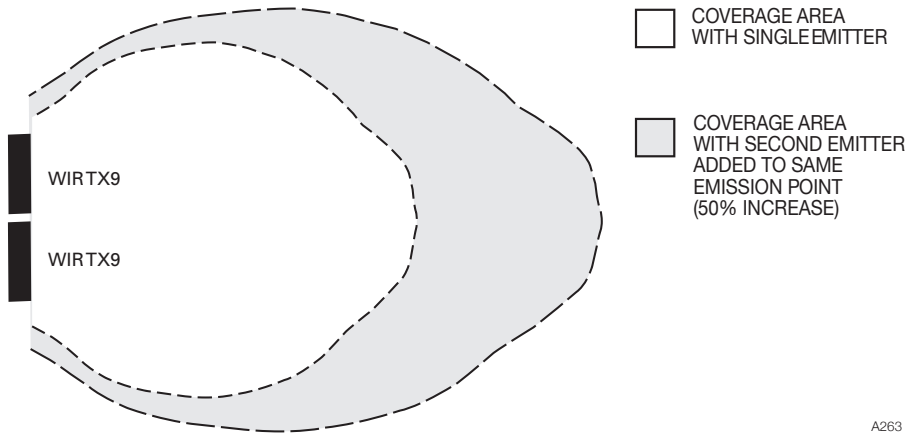

A263

Figure 13: Connecting Multiple TX9 Emitters

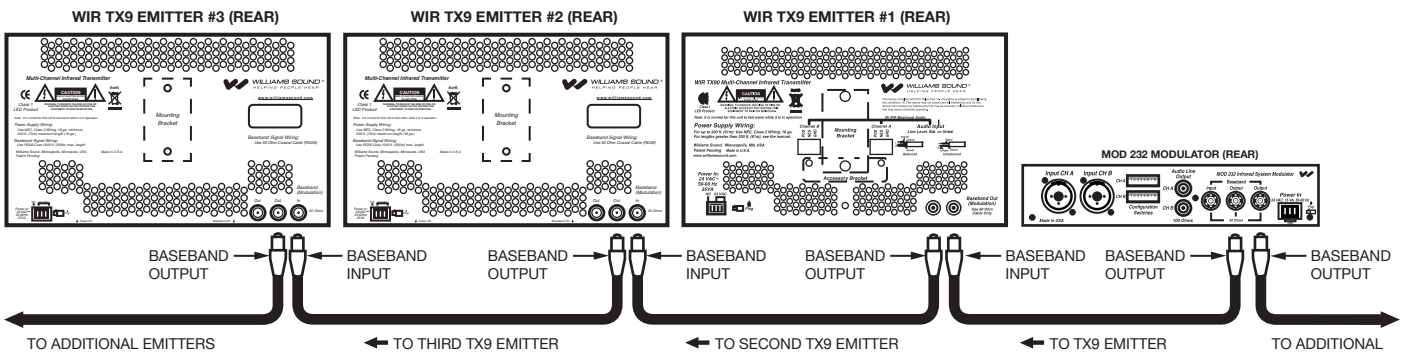

A256

An unlimited number of WIR TX9 emitters can be daisy-chained together to maximize the coverage area.

Remember that each emitter needs its own power supply and cannot share a power supply with a modulator or another emitter.

Compressor Gain

The MOD 232's Compressor Gain is set in "Moderate" mode from the factory. Use this setting for simultaneous interpretation. Be sure that the compress pot control, located on the front of the MOD 232 (Figure 6, page 6), is turned fully counter-clockwise. Compression can be added if desired by turning the compress pot control clockwise.

For hearing assistance applications, the MOD 232's Compressor Gain can be set to "Maximum" mode. For additional compression, use a tuning wand (PLT 005) or small screw driver and gently turn the compress pot (Figure 6, page 6) on the front of the MOD 232 clockwise.

The difference between "Moderate" and "Maximum" Compressor Gain is illustrated below:

Figure 14

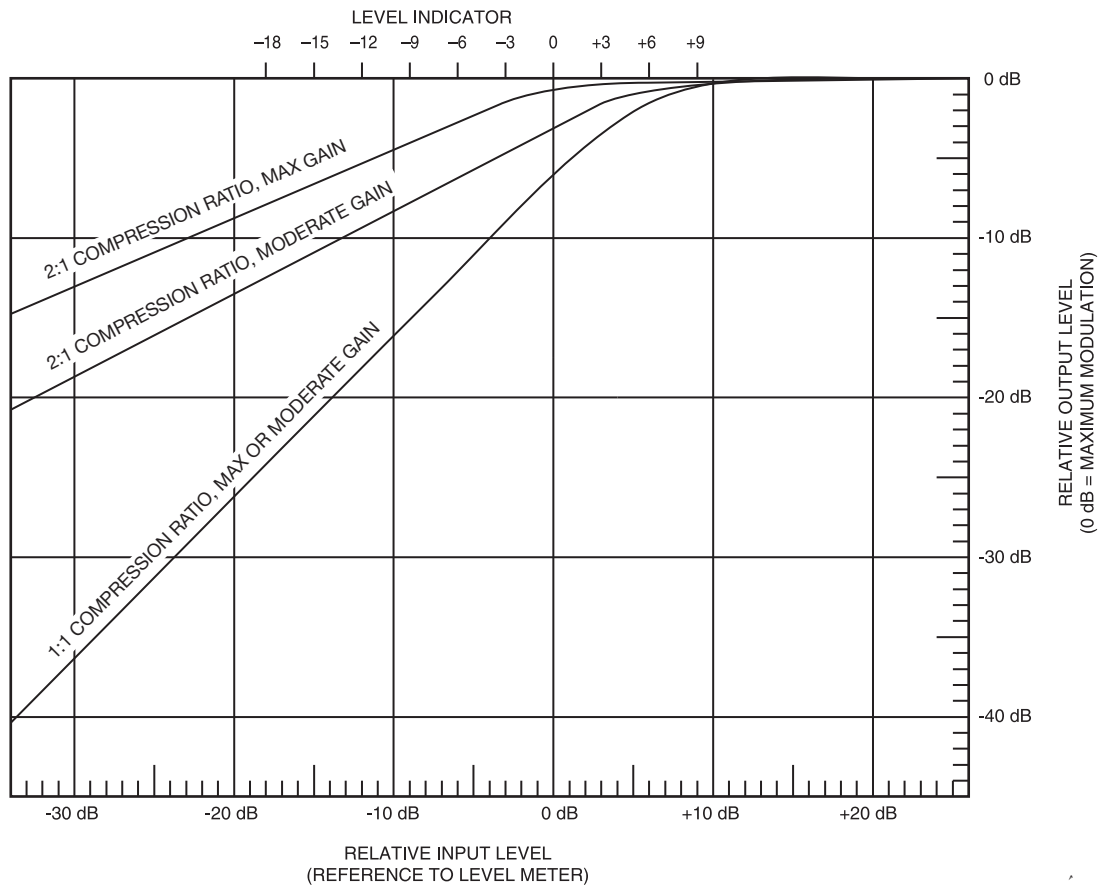

To setup the MOD 232 for "Moderate" Compressor Gain: Place switch 1 in the **↑** "on" position.

To setup the MOD 232 for "Maximum" Compressor Gain: Place switch 1 in the **↓** "off" position.

TX9 Features and Controls

Figure 15: TX9 Emitter Rear View

Mounting the TX9

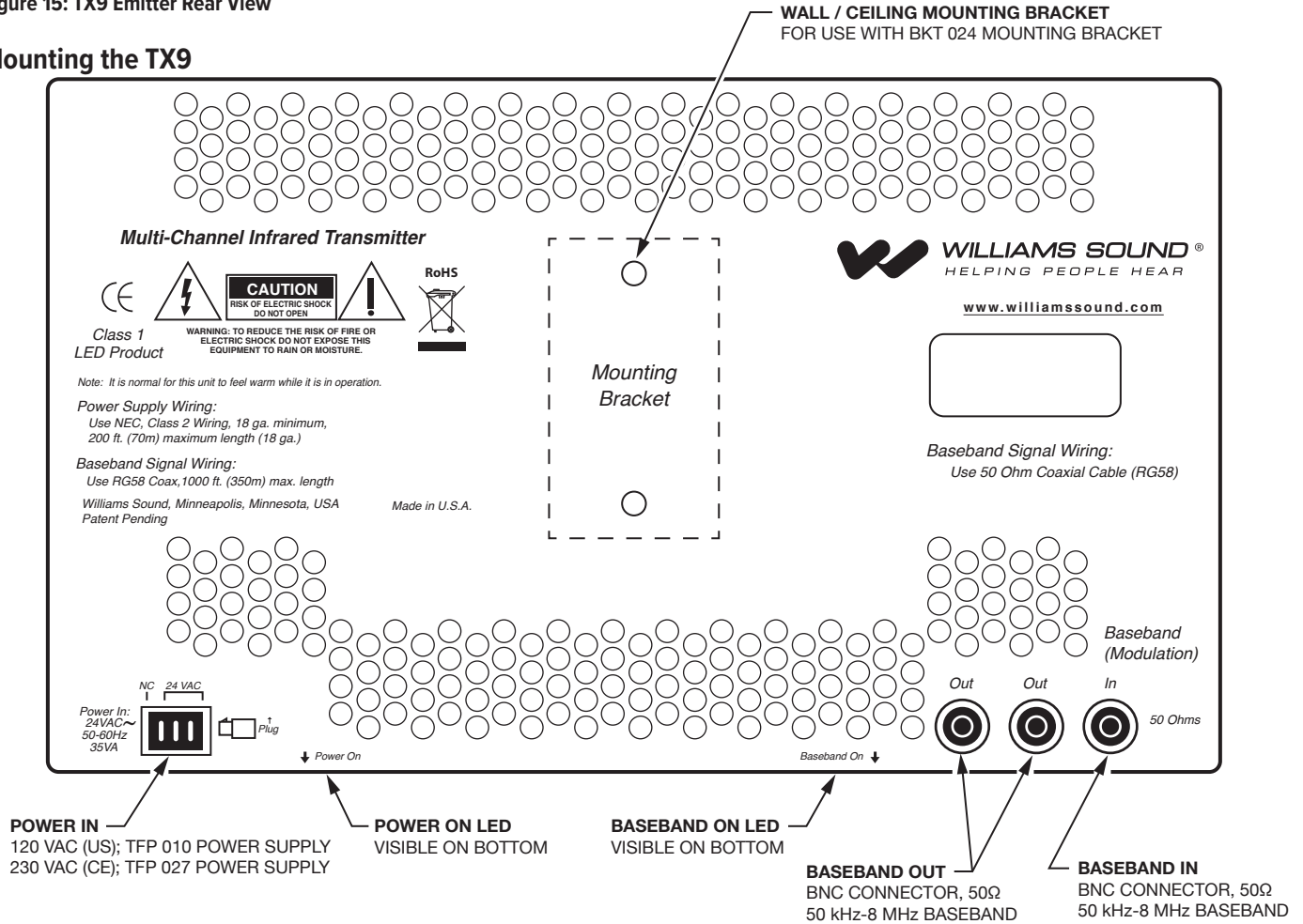

A257

Figure 16: Mounting the TX9 to a wall, ceiling, or suspended ceiling with the BKT 024 using a Mounting Plate or a T-Bar Clip

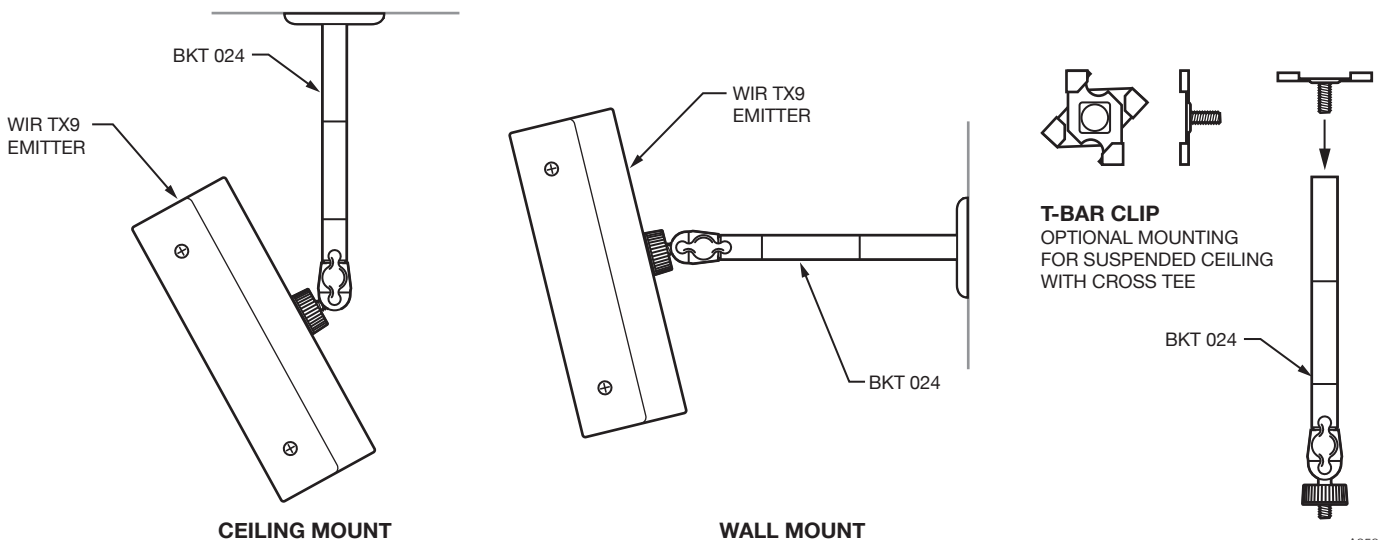

A258

Receiver Safety Information

HEARING SAFETY

CAUTION!

This product is designed to amplify sounds to a high volume level which could potentially cause hearing damage if used improperly. To protect your hearing and the hearing of others:

1. Turn the volume down before putting on the earphone or headphone, and then adjust the volume to a comfortable level.
2. Set the volume level at the minimum setting that you need to hear.
3. If you experience feedback (a squealing or howling sound), reduce the volume setting and move the microphone away from the earphone or headphone.
4. Do not allow children or other unauthorized persons to have access to this product.

BATTERY SAFETY

CAUTION!

This product is supplied with disposable Alkaline batteries. Do not attempt to recharge disposable batteries, which may explode, release dangerous chemicals, cause burns, or other serious harm to the user or product.

MEDICAL DEVICE SAFETY

CAUTION!

1. Before using this product with an implantable or other medical device, consult your physician or the manufacturer of your implantable or other medical device.
2. If you have a pacemaker or other medical device, make sure that you are using this product in accordance with safety guidelines established by your physician or the implantable device manufacturer.

Recycling Instructions



Battery Safety and Disposal

Help Williams Sound protect the environment! Please take time to dispose of your equipment properly. Please do NOT dispose of batteries in the household trash. Please take the batteries to a retail or community collection point for recycling.



Product Recycling:

Please do NOT dispose of your Williams Sound equipment in the household trash. Please take the equipment to an electronics recycling center or return the product to the factory for proper disposal.

Infrared Receivers

Figure 13: Four Channel Receiver, Model WIR RX22-4

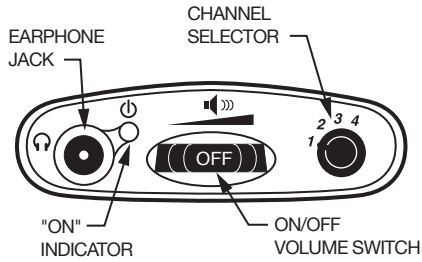

Channel	Frequency
1	2.3 MHz
2	2.8 MHz
3	3.3 MHz
4	3.8 MHz

Figure 14: WIR RX15-2 Headset Receiver

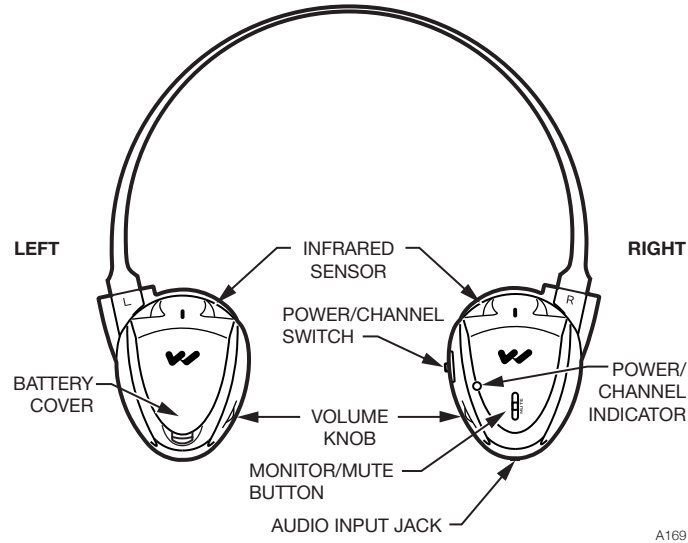
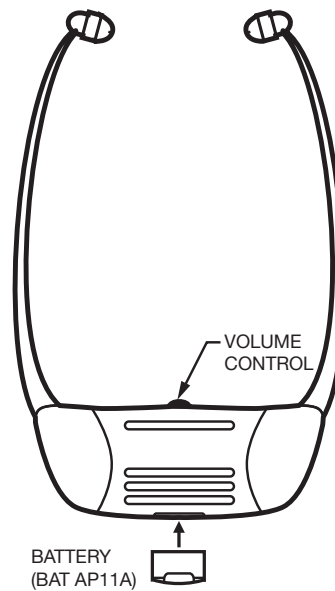

Figure 15: WIR RX18 Under-the-chin Receiver



Trouble Shooting

TX9 Indicator Light Is Not On.

- Make sure the transformer is plugged into the emitter and any remote power switch is on.
- Make sure the electrical outlet is on.
- Make sure the 24 VAC power supply is working.

Only TX9's Power Indicator LED Comes On.

- Make sure the MOD 232 is on.
- Make sure the baseband cable is connected properly. See page 5, Figures 3 & 4.
- Check to see if the carrier light on the MOD 232 is on.
- Make sure an audio signal is being sent to the MOD 232.

No Sound Through Receivers.

- If some of the receivers work but others don't, check for bad batteries or earphones on the receivers that aren't working.
- If none of the receivers work, check to see if the power and baseband cable are connected to the emitter and that the TX9 Power and Baseband Present Indicator lights are ON.
- Check to see if the modulator is connected properly to the sound system. The Frequency Indicator should be lit and there should be activity on the MOD 232 Level Indicators.
- Make sure the "eye" is not covered up on the receiver. There must be clear line of sight between the receiver eye and the emitter panel.

Sound Through The Receivers Is Weak And Noisy.

- Make sure each channel is set to a different frequency on the MOD 232 modulator. Listen to the audio signal through the Phones jack of the MOD 232 modulator. You can also hold a receiver in front of the Infrared Test LED on the front of the MOD 232 modulator and listen to the audio signal. If the signal is weak and noisy here, check the Input Level switch and Input Level Control settings. Increase the input signal level from the sound system by turning up the mixer control. If the signal sounds okay, you may need to re-position the emitter panels or add additional panels.

NOTE: Make sure the powerline voltage does not fall below 94V, or system performance will be greatly reduced!

Buzzing Or Humming Noise In Sound System.

- Check for ground loops or noise on the input signal. Call your Authorized Williams Sound dealer or representative.

SoundPlus® Infrared Listening System Specifications

Two-Channel Modulator, Model MOD 232

Size, Weight:	8.5" W x 8.2" D x 1.7" H (21.5 cm x 20.8 cm x 4.4 cm), 3.1lbs. (1.5 kg)
Color:	Black epoxy paint with white legends
Rack Mount:	1/2 rack space wide, 1 rack space high, one or two modulators may be mounted in a single IEC rack space with RPK 005 (single) or RPK 006 (double) Rack Mount Kits
Power Supply:	Wall Transformer, 24VAC, 50-60 Hz, 15VA North America: TFP 016, UL/CSA Europe: TFP 027-01, 2-pin Schuko plug, CE UK: TFP 027-02, 3-pin UK plug, CE
Modulation:	FM Wideband, +50kHz deviation, 50uS pre-emphasis
Carrier Frequency:	Channel A: Selectable, 2.3/2.8/3.3/3.8MHz, Channel B: Selectable, 2.3/2.8/3.3/3.8MHz
Signal to Noise Ratio:	More than 60dB
Frequency Response:	30 to 16,000Hz, +1 dB, -3dB, electrical response
Total Harmonic Distortion:	Less than 2%, electrical response
Audio Processing:	Compression (slope) adjustable from 1:1 to 2:1 Switchable compression gain: Moderate: 16dB. Max: 33dB
Auto Carrier Shut-Off:	15 minute timer shuts off carrier when no audio is present (can be disabled)
Power Switch:	Two-position push button, ON/OFF
Power Indicator:	Green LED
Audio Level Controls:	CHA and CHB Input Level, rotary knobs
Audio Indicators:	CHA and CHB Audio Level, 10-segment LED's
Carrier LEDs:	4 green LED carrier "on" indicators per channel (indicates frequency, malfunctions)
Compress Control:	1:1 or 2.0:1
Input Mix LED:	Indicates inputs A and B audio are mixed and transmitted by CHA. CHB off
Stereo LED:	Indicates stereo mode
Phones Switch:	Selects CH1 or CH2 for phones when not in stereo mode
Phones Output:	1/4" TRS headphone jack. Accepts stereo, mono, and any impedance phones.
Infrared Test LED:	IR LED for receiver testing, monitoring, and audio signal testing.
Power Input:	3-Pin Molex, 24VAC, 50-60Hz, 15 VA
Audio Input Jack:	CHA and CHB combination XLR/TRS jack Mic Level: Balanced, Lo-Z, 100µV min. to 90 mV max., 1mV nominal, 3kΩ input impedance, supplies switchable simplex power per DIN 45596 for condenser mics Line Level: Balanced or unbalanced, 21mV min. to 10V max., 212mV nominal, 100kΩ
Audio Line Output Jacks:	RCA Jack, CHA and CHB, 500mV, unbalanced, 100Ω source impedance, load impedance must be greater than 1kΩ
Configuration Switches:	CHA and CHB 8-position DIP switch, selects Mic/Line input, compressor gain, simplex power, discrete or mixed inputs, carrier frequency, channel disable, auto shut-off timer.
Baseband Input Jack:	BNC, allows mixing with additional MOD 232 Modulator (4CH operation), 100mV, 50Ω input impedance, use with MOD 232, BNC, RG-58 Cable
Baseband Output Jack:	Two BNC jacks carry baseband signal, 100mV/channel, 50Ω source impedance, for use with WIR TX9 or MOD 232 only
Approvals:	CE, FCC, RoHS, WEEE
Operating requirements:	0-50° C ambient temperature, non-condensing, non-corrosive atmosphere
Warranty:	5 years on Modulator, 90 days on accessories

NOTE: SPECIFICATIONS SUBJECT TO CHANGE WITHOUT NOTICE.

SoundPlus® Infrared Listening System Specifications

Multi-Channel Infrared Emitter, Model TX9

NOTE: SPECIFICATIONS SUBJECT TO CHANGE WITHOUT NOTICE.

Dimensions, Weight:	11.25" W x 6.25" H x 2.125" D (28.6 cm x 15.9 cm x 5.4 cm), 1.9 lbs (0.9 kg)
Color:	Black with white legends, red acrylic lens (also available in white)
Power Supply:	Wall Transformer, 24 VAC, 50-60Hz, 35 VA, 3-pin MOLEX Connector North America: TFP 010, UL/CSA Europe: TFP 027-01, 2-pin Schuko plug, CE UK: TFP 027-02, 3-pin UK plug, CE Note: Each WIR TX9 requires its own power supply
Power Cable:	NEC Class 2 wiring, two-conductor, 18 ga, 200' (61m) max. length
Indicators:	Green LED power indicator, red LED baseband indicator
Carrier Frequency:	50 kHz to 8 MHz
Emitter IR Power:	3.5 watts
Coverage Area:	28,000 sq. ft. (2600 sq. m) in single channel mode when using the RX22-4 Receiver 18,000 sq. ft (1700 sq. m) in two channel mode when using the RX22-4 Receiver 11,000 sq. ft (1000 sq. m) in four channel mode when using the RX22-4 Receiver 3,500 sq. ft (325 sq. m) in single channel mode when using the RX15-2 Receiver 3,063 sq. ft (285 sq. m) in single channel mode when using the RX18 Receiver (See coverage area diagrams)
Baseband Input:	BNC, 100 mV per carrier, 50 Ω, for use with WIR TX9 or MOD 232 only
Baseband Output:	BNC, 50 Ω, for use with TX9 only
Baseband Cable:	RG 58 Coax, BNC connectors, maximum 1000' (300m) length
Operating Requirements:	0-50° C ambient temperature, non-condensing, non-corrosive atmosphere
Mounting Kits:	Wall or Ceiling Mount: BKT 024 Omnidirectional mount, Mic Stand Kit: SS-11 or SS-6
Warranty:	5 years on emitter, 90 days on accessories
Approvals:	CE, FCC, RoHS, WEEE
Compatible Receivers:	WIR RX22-4 Four-Channel Receiver, RX18 Two-Channel Receiver, RX15-2 Two-Channel Receiver

Visit our website for the latest specifications and publications: www.williamsav.com

Limited Warranty

Williams Sound (a division of Williams AV) products are engineered, designed, and manufactured under carefully controlled conditions to provide you with many years of reliable service. Williams Sound warrants the SoundPlus™ Infrared Listening System against defects in materials and workmanship for FIVE (5) years. During the first five years from the purchase date, we will promptly repair or replace the SoundPlus® Infrared Listening System.

Microphones, earphones, headphones, batteries, cables, carry cases, and all other accessory products carry a 90-day warranty. Chargers carry a one year warranty.

WILLIAMS SOUND HAS NO CONTROL OVER THE CONDITIONS UNDER WHICH THIS PRODUCT IS USED. WILLIAMS SOUND, THEREFORE, DISCLAIMS ALL WARRANTIES NOT SET FORTH ABOVE, BOTH EXPRESS AND IMPLIED, WITH RESPECT TO THE SOUNDPLUS™ INFRARED LISTENING SYSTEM, INCLUDING BUT NOT LIMITED TO, ANY IMPLIED WARRANTY OF MERCHANTABILITY OR FITNESS FOR A PARTICULAR PURPOSE. WILLIAMS SOUND SHALL NOT BE LIABLE TO ANY PERSON OR ENTITY FOR ANY MEDICAL EXPENSES OR ANY DIRECT, INCIDENTAL OR CONSEQUENTIAL DAMAGES CAUSED BY ANY USE, DEFECT, FAILURE OR MALFUNCTIONING OF THE PRODUCT, WHETHER A CLAIM FOR SUCH DAMAGES IS BASED UPON WARRANTY, CONTRACT, TORT OR OTHERWISE. THE SOLE REMEDY FOR ANY DEFECT, FAILURE OR MALFUNCTION OF THE PRODUCT IS REPLACEMENT OF THE PRODUCT. NO PERSON HAS ANY AUTHORITY TO BIND WILLIAMS SOUND TO ANY REPRESENTATION OR WARRANTY WITH RESPECT TO THE SOUNDPLUS™ INFRARED LISTENING SYSTEM. UNAUTHORIZED REPAIRS OR MODIFICATIONS WILL VOID THE WARRANTY.

The exclusions and limitations set out above are not intended to, and should not be construed so as to contravene mandatory provisions of applicable law. If any part or term of this Disclaimer of Warranty is held to be illegal, unenforceable, or in conflict with applicable law by a court of competent jurisdiction, the validity of the remaining portions of this Disclaimer of Warranty shall not be affected, and all rights and obligations shall be construed and enforced as if this Limited Warranty did not contain the particular part or term held to be invalid.

If you experience difficulty with your system, call Toll-Free for customer Assistance:

1-800-843-3544 (U.S.A.) or +1 952 943 2252 (Outside the U.S.A.)

If it is necessary to return the system for service, your Customer Service Representative will give you a Return Authorization Number (RA) and shipping instruction.

Pack the system carefully and send it to:

**Williams AV LLC.
Attn: Repair Dept.
10300 Valley View Road
Eden Prairie, MN 55344 USA**

Your warranty becomes effective the date you purchase your system. Your returned warranty card is our way of knowing when your warranty begins. Please take a moment to fill it out and mail the enclosed card. You may also register your product online at www.williamsav.com. This information will help us serve you better in the future. Thank you!

This page has been left blank.

