



AcousticDesign™ Series

AD-C6T-WH

AD-C6T-BK

Small format, ceiling mount
loudspeaker

Features

- Consistent tonal characteristics across the entire AcousticDesign family for surface, ceiling, and pendant applications
- DMT (Directivity Matched Transition™) waveguide ensures smooth, uniform frequency response over the coverage area
- Snap-fit magnetic grille
- 3x double stepped, long travel dog-ear blind mount system
- Intrinsic Correction™ voicings available via Q-SYS networked audio processing platforms, including CXD amplifiers
- Low-saturation and low-loss 70/100V transformers with 16Ω bypass
- Blemish-free removable logo
- Removable conduit cover plate, also available as accessory for pre-install wiring
- UL1480 and UL2043 certified EN54-24 Type A (pending)
- Available in black (RAL 9011) or white (RAL 9010)
- Complete EASE, CF2, CAD, & BIM information available online



Restaurant · Retail · Audio Visual · Education · Concourses · Casinos · Transportation Terminals · Worship Facilities · Large System Ancillary Support

The QSC AcousticDesign™ AD-C6T is a 6.5" two-way ceiling loudspeaker ideally suited for a wide variety of foreground and background sound reinforcement applications which utilize 70/100V or 16Ω bypass configurations.

The AcousticDesign™ series offers integrators a premium quality installed sound solution where performance, consistent coverage, and aesthetics are paramount. Specifically designed to maintain a consistent tonal characteristic across the entire family in ceiling, surface, and pendant applications, the AcousticDesign series allows integrators seamless transitions within blended installations.

The AD-C6T features a high quality 6.5" weather treated paper cone woofer with a 1" voice coil and a .75" aluminum dome tweeter which is positioned on a DMT waveguide.

DMT (Directivity Matched Transition™) is QSC's design philosophy where the high frequency waveguide is matched to the natural conical behavior of the woofer at the crossover point. The result is a coherent transition between transducers with improved off-axis power response for consistent 135° conical DMT coverage.

The accurate frequency response of the AD-C6T is maintained even in 70/100V applications by use of a low-loss, low-saturation 60-watt transformer with selectable taps, including 16Ω bypass, using a rotary selector located under the

snap-fit magnetically attached powder coat steel grille.

To retain lasting good looks, the rugged ABS baffle is further protected by using UV inhibitors that prevent discoloration and by a powder coated steel back can. The magnetic grille features a stick-on logo that can be removed blemish-free for installations where branding is not permitted.

Installers will appreciate the 3x double stepped, long travel dog-ear blind mounting system, which captures from 0" - 2.25" of ceiling thickness. A captured Phillips screw provides access to the removable conduit cover plate; also available as an accessory, as is a separate mud-ring for pre-install wiring. A locking 4-pole Euro-block connector that can accept four 18AWG pairs eliminates the termination hassles of star topology wiring designs.

Intrinsic Correction™ voicings that optimize performance and speed the install process are easily deployed via Q-SYS networked audio processing platforms, including CXD power amplifiers, as part of a complete QSC systems solution.

The AD-C6T is available in QSC standard black (RAL 9011) or white (RAL 9010) and may be painted to match any decor.

For your system integration needs, complete EASE, CF2, CAD, and BIM files are available for download at QSC.com.

AD-C6T Details

Impedance / Frequency Response:

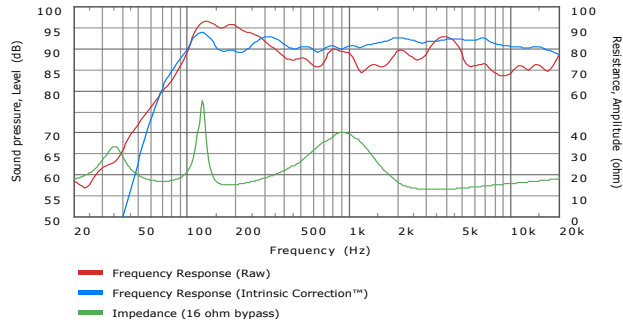

Beamwidth:

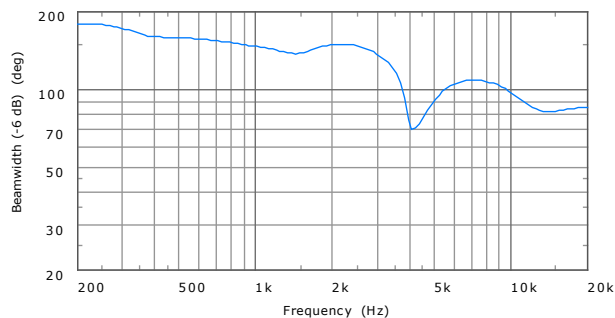

Dimensions:

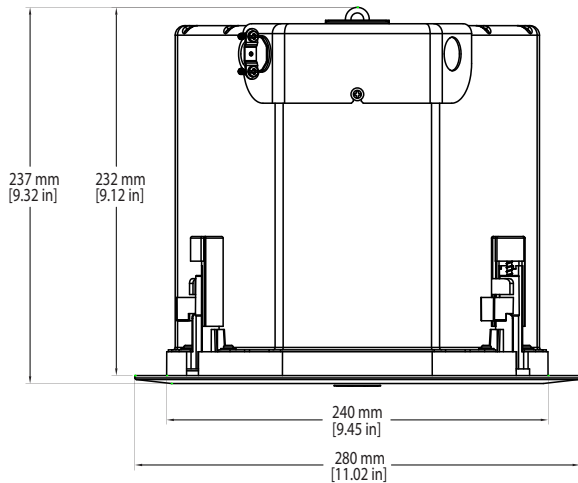

As part of QSC's ongoing commitment to product development, specifications are subject to change without notice.

Specifications

System Details	AD-C6T
Effective frequency range ¹	65 Hz – 20 kHz
Rated noise power / voltage ²	60 watts / 31 volts (rms)
Sensitivity [dB] ³	88
Sensitivity at 4m, 100V maximum tap	TBD
Rated coverage (-6 dB) ⁴	135° conical DMT
One-third octave frequency band contribution at full power using 100V maximum tap at 4m. (Hz / dB)	500 / TBD; 630 / TBD; 800 / TBD 1000 / TBD; 1250 / TBD; 1600 / TBD 2000 / TBD; 2500 / TBD; 3150 / TBD 4000 / TBD
Directivity factor ⁴	6.5
Directivity index [dB] ⁴	8
Maximum continuous SPL [dB] ⁵	106
Maximum peak SPL [dB] ⁵	112
Nominal impedance [ohms]	16
Recommended amplifier	120 watts
Transformer taps / impedance	16Ω (in bypass setting) 7.5W (70V); 15W (100V) Tap: 667Ω 15W (70V); 30W (100V) Tap: 333Ω 30W (70V); 60W (100V) Tap: 167Ω 60W (70V); N/A (100V) Tap: 83Ω
LF transducer	165 mm [6.5 in] weather treated paper cone woofer
HF transducer	19 mm [.75 in] aluminum dome tweeter
Input connector type	Euroblock connector with parallel output
Enclosure material	ABS baffle on powder coated steel back can
Grille material	Powder coated steel
Ingress protection	IP-34
Operating environment	Designed for indoor use
Operating temperature range	-20 to 50° C [-4 to 122° F]
Cutout dimension	Ø 245 mm [Ø 9.65 in]
Net weight	4.3 kg [9.5 lb]
Product dimensions (Diameter x Height)	Ø 280 x 237 mm [Ø 11.02 x 9.32 in.]
Shipping weight	12.6 kg [27.8 lb] (pair packed)
Shipping dimensions (H x W x D)	330 x 737 x 381 mm [13 x 29 x 15 in] (pair packed)
Included accessories	C-ring and tile rails, rail screws, euroblock connector, cut-out template, tether grille
Optional accessories	AD-MR6 (pre-install mud ring) AD-CC6 (pre-install conduit cover)
Safety Agency	EN54-24: 2008 type A (No. pending) UL1480, UL2043, NFPA90, NFPA70 suitable for use in air handling spaces. Transformer UL registered per UL1876, ROHS, C-Tick (pending), CE compliant. Baffle meets UL94-V0 and UL94-5VB flammability rating; in accordance with IEC60849 / EN60849 systems.

² -10dB from rated sensitivity

¹ IEC noise, 2hrs

⁴ 500 Hz–5 kHz average

³ Transformer bypassed, 1W, 1m, IEC baffle,

200-10kHz average, on-axis

⁵ Calculated from rated noise voltage and sensitivity



1675 MacArthur Boulevard • Costa Mesa, CA 92626 • Ph: 800/854-4079 or 714/957-7100 • Fax: 714/754-6174

© 2016 QSC, LLC all rights reserved. QSC and the QSC logo are registered trademarks of QSC, LLC in the U.S. Patent and Trademark office and other countries. All other trademarks are the property of their respective owners. Patents may apply or be pending.

AD-C6T Spec Sheet 06/24/2016



please recycle