

# System Power Amplifier (SPA)



## Installation Guide

SPA2-60 Amplifier

SPA4-60 Amplifier

### EXPLANATION OF SYMBOLS

The term **"WARNING!"** indicates instructions regarding personal safety. If the instructions are not followed the result may be bodily injury or death.

The term **"CAUTION!"** indicates instructions regarding possible damage to physical equipment. If these instructions are not followed, it may result in damage to the equipment that may not be covered under the warranty.

The term **"IMPORTANT!"** indicates instructions or information that are vital to the successful completion of the procedure.

The term **"NOTE"** is used to indicate additional useful information.









The intent of the lightning flash with arrowhead symbol in a triangle is to alert the user to the presence of un-insulated "dangerous" voltage within the product's enclosure that may be of sufficient magnitude to constitute a risk of electric shock to humans.

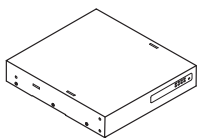
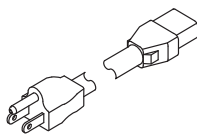
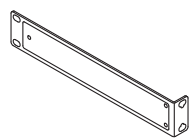
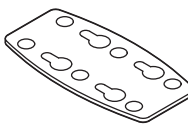

The intent of the exclamation point within an equilateral triangle is to alert the user to the presence of important safety, and operating and maintenance instructions in this manual.

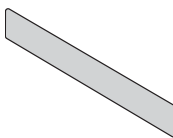
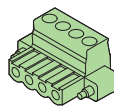
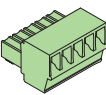
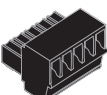
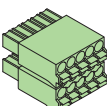
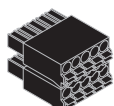
### What's in the Box

 (1x)	 (1x)	 (2x)	 (2x)
 (2x)	 (6x)	 (6x)	 (4x)
 (1x)	 SPA2-60 (1x) SPA4-60 (2x)	 SPA2-60 (1x)	 SPA2-60 (1x)
 SPA4-60 (1x)	 SPA4-60 (1x)	 (1x) Warranty TD-000453	 (1x) Safety Information TD-000337

TD-000500-01-A



# Installation

## Ventilation

- Recommend 1RU (1.75 in / 44.45 mm) space above the amplifier.
- Minimum open space of 6 inches measured from back of amplifier.



**NOTE:** QSC System Power Amplifiers contain advanced protection circuitry which allows them to reduce output power in order to maintain safe operating temperatures. Insufficient ventilation may result in the amplifier reducing output power during normal operation (indicated by Limiter/Protect LEDs illuminating red). To reduce the possibility of thermal limiting, and allow proper heat dissipation, we recommend that you keep the space directly above and to the rear of these amplifiers free of obstacles.

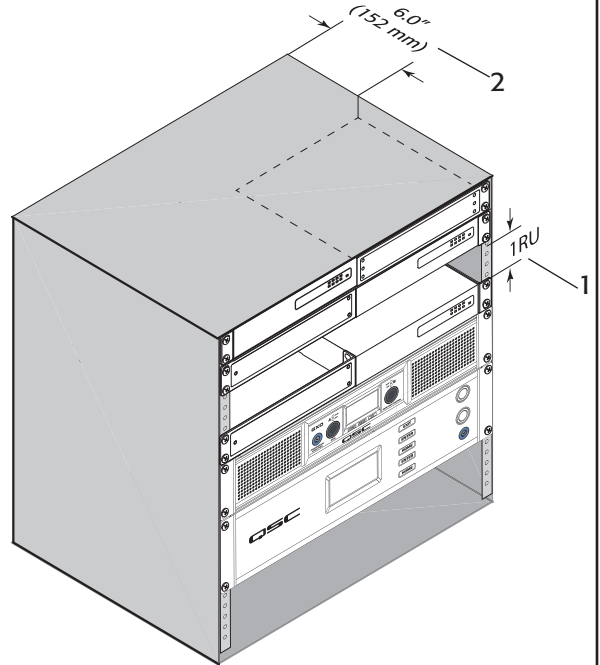

– Figure 1 –

## Select the Amplifier Installation Configuration

Choose one of the following configuration options:

- |   |  |
|---|--|
| A. One Amplifier 19-inch Rack (Left or Right Mount) on page 3       | D. Under Table or on Wall on page 4      |
| B. Two Amplifiers 19-inch Rack (Front or Rear Facing Out) on page 3 | E. Free-Standing on Desk/Table on page 5 |
| C. One Amplifier Half Rack (Front or Rear Facing Out) on page 4     | F. Plenum Installation on page 5         |

**A. One Amplifier 19-inch Rack (Left or Right Mount)**

Figure 2

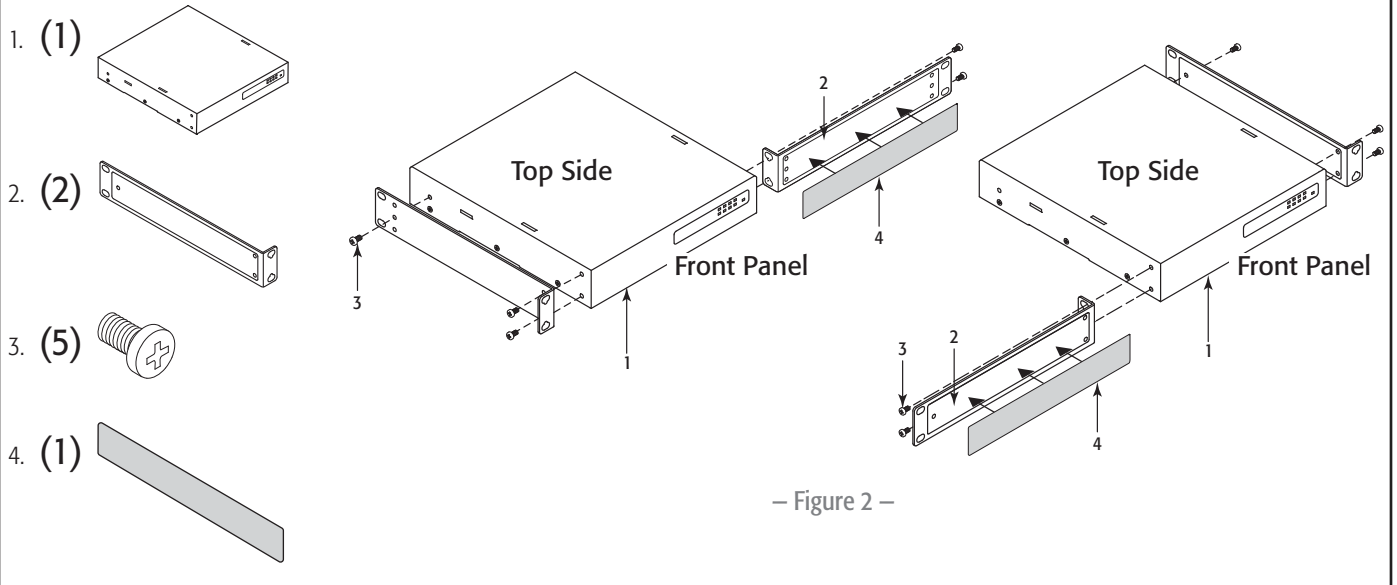

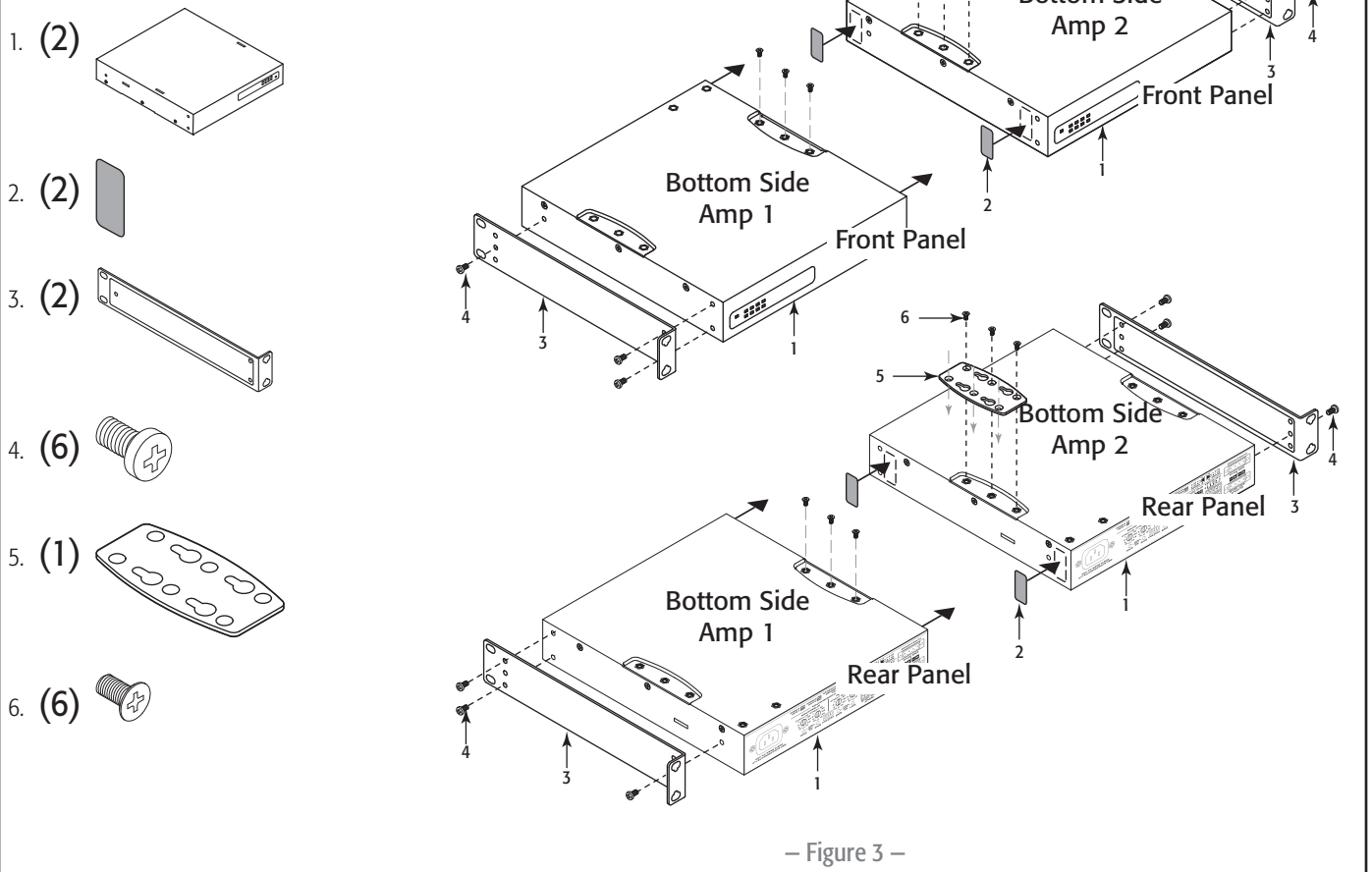

**B. Two Amplifiers 19-inch Rack (Front or Rear Facing Out)**

Figure 3

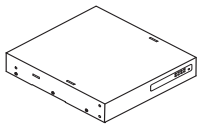
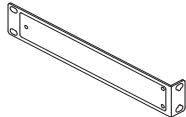

### C. One Amplifier Half Rack (Front or Rear Facing Out)

Figure 4

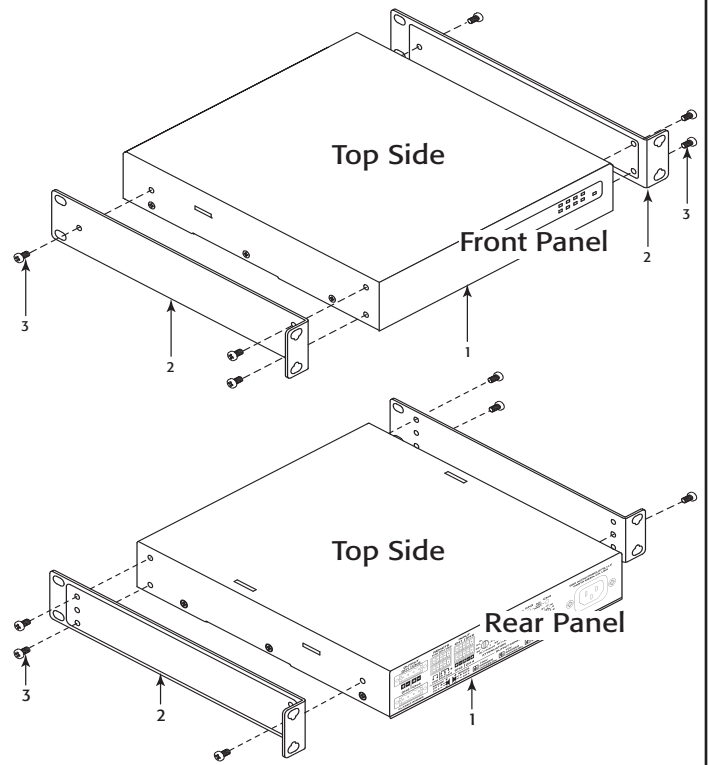

1. (1) 
2. (2) 
3. (6) 



– Figure 4 –

### D. Under Table or on Wall

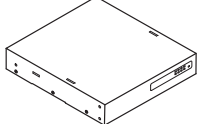
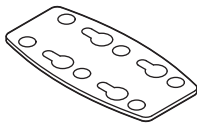
Figure 5.

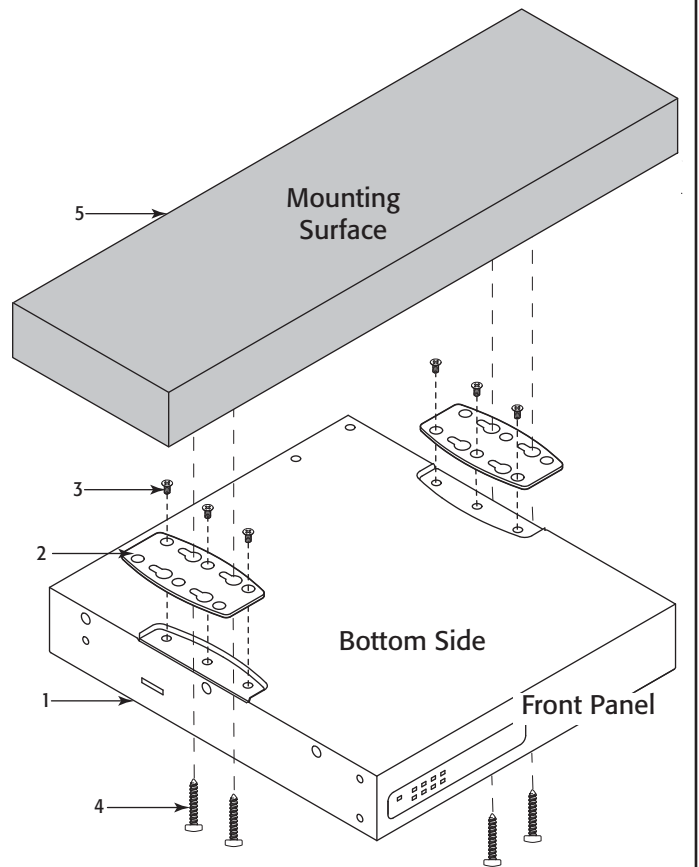

1. (1) 
2. (2) 
3. (6) 
4. (4)  Not supplied – use appropriate screws for mounting surface.



– Figure 5 –

## E. Free-Standing on Desk/Table

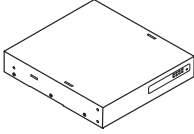
Figure 6

1. (1) 
2. (4) 

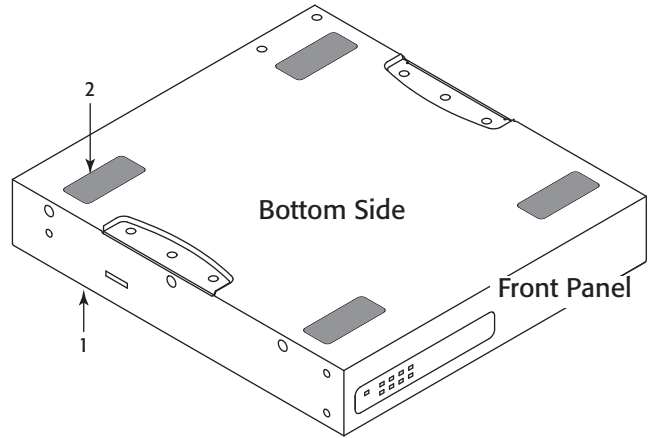

– Figure 6 –

## F. Plenum Installation

Configure amplifier per option D Under Table or on Wall.

Figure 7

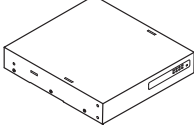
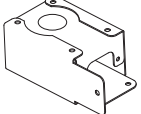
1. (1) 
2. (1)  Plenum Kit - Suitable for Air Handling Spaces only when used with optional Plenum Kit (FG-000995-00) sold separately.

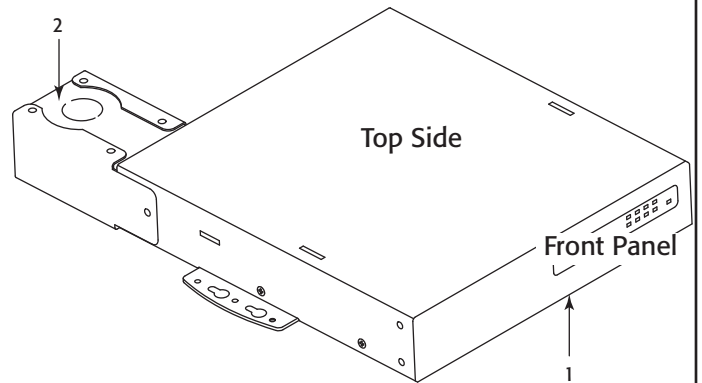

– Figure 7 –

## Rack-Mounting Options

### All Configurations

Figure 8

Using the examples shown, you can mount any of the amplifier configurations. The example at the lower right of Figure 8 can be flipped to accommodate a single amplifier on the left side.

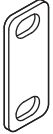
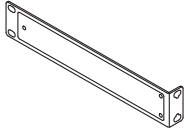
1. Equipment Rack (not supplied)
2. (2)  Optional – to bring flush with Q-Sys Core 110
3. (2) 
4. (4) Rack-Mounting Screws and Washers (not supplied)

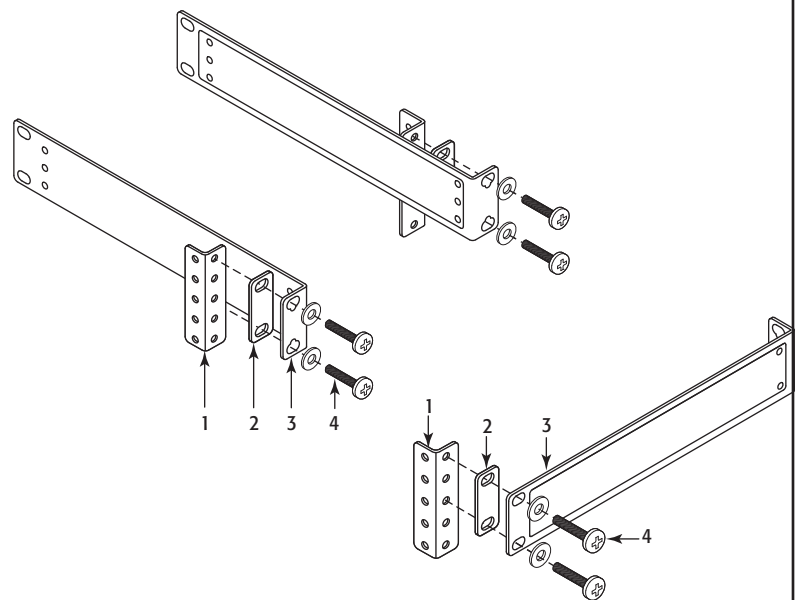

– Figure 8 –

# Front Panel

## 2 CHANNEL AMPLIFIER SPA2-60

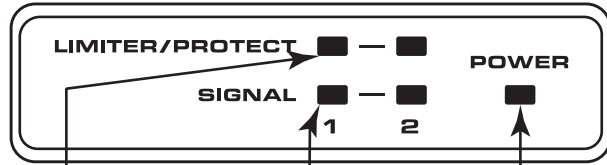

**Limiter / Protect**  
Red – Protect / Mute  
Orange – Limiter on

**Input Signal**  
Blue – Present

**Power**  
Blue – On  
Orange – Standby

## 4 CHANNEL AMPLIFIER SPA4-60

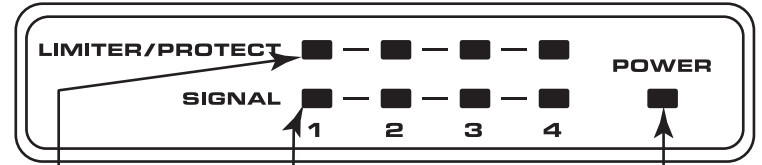

**Limiter / Protect**  
Red – Protect / Mute  
Orange – Limiter on

**Input Signal**  
Blue – Present

**Power**  
Blue – On  
Orange – Standby

– Figure 9 –

# Rear Panel

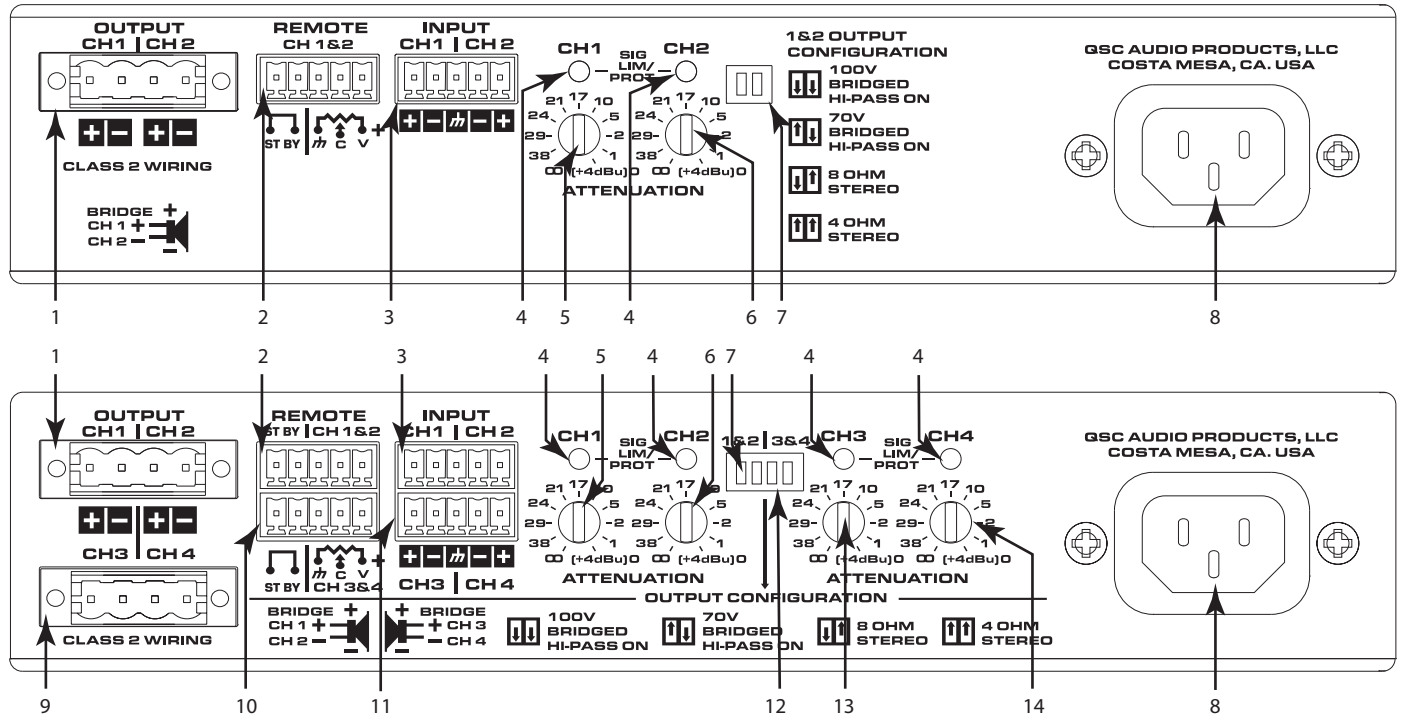

– Figure 10 –

- |  |  |   |
|--|--|---|
| 1. Output Channels 1 & 2   | 5. Channel 1 Attenuator Control              | 10. Remote Control Channel 3 & 4              |
| 2. Remote Control Channels 1 & 2                                     | 6. Channel 2 Attenuator Control              | 11. Input Channels 3 & 4                      |
| 3. Input Channels 1 & 2  | 7. Mode Configuration Switches Channel 1 & 2 | 12. Mode Configuration Switches Channel 3 & 4 |
| 4. Channel 1 thru Channel 4 Status LEDs                              | 8. AC Power Connection                       | 13. Channel 3 Attenuator Control              |
| a. Green – Normal Signal Level                                       | 9. Output Channels 3 & 4                     | 14. Channel 4 Attenuator Control              |
| b. Amber – Input or Output Overload/<br>Clipping or Thermal Limiting |  |   |
| c. Red – Limit or Protect Mode                                       |  |   |
| d. Red – Thermal Limit or Protect Mode                               |  |   |
| e. Red – Mute <sup>1</sup>   |  |   |

<sup>1</sup> No signal for 10 minutes, amplifier outputs are muted (LEDs are red). No signal for 25 minutes, amplifier is put in Standby Mode (Rear LEDs are off).

# Connections

## Wire



**IMPORTANT:** Class 2 Wiring



Strip Length = 5mm

DO NOT TIN!

– Figure 11 –

## Output Connectors



**IMPORTANT:** Class 2 Wiring

Figure 12 – Figure 13

### SPA2-60

(1)

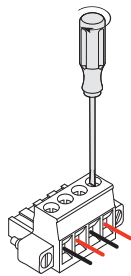
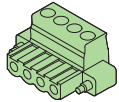

– Figure 12 –

### SPA4-60

(2)

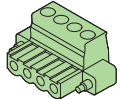

### SPA4-60

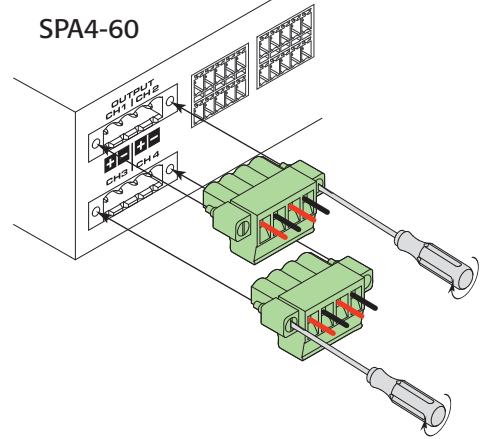

– Figure 13 –

## Input Connectors

### SPA2-60 Connector

Figure 14 – Figure 15

(1)

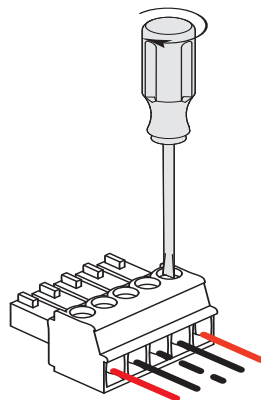
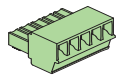

– Figure 14 –

### SPA4-60 Connector

Figure 16 – Figure 17

(1)

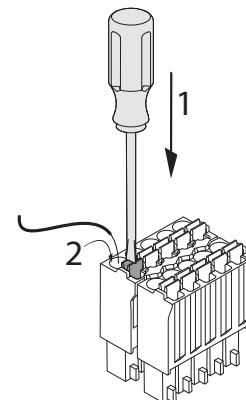
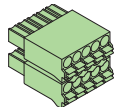

– Figure 16 –

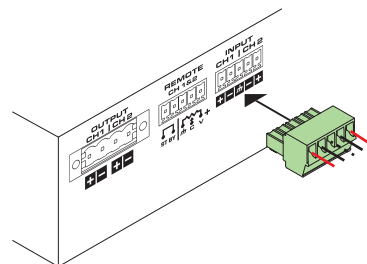

– Figure 15 –

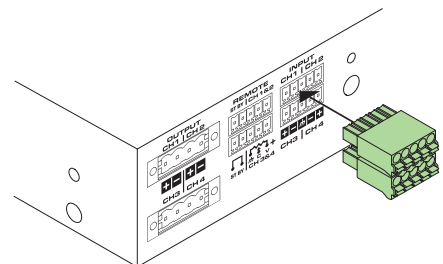

– Figure 17 –

## Balanced and Unbalanced Inputs

Figure 18

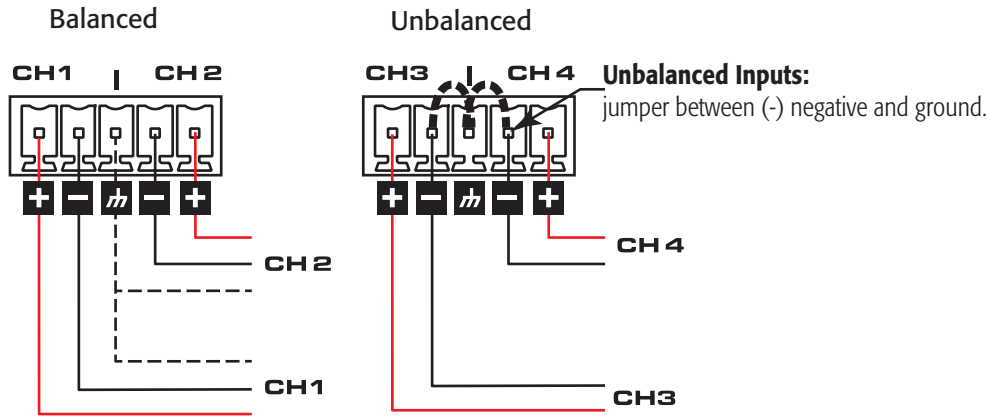

– Figure 18 –

## Stereo Mode

Figure 19 – Figure 21



– Figure 19 –



**CAUTION!:** Do not connect any output to ground.

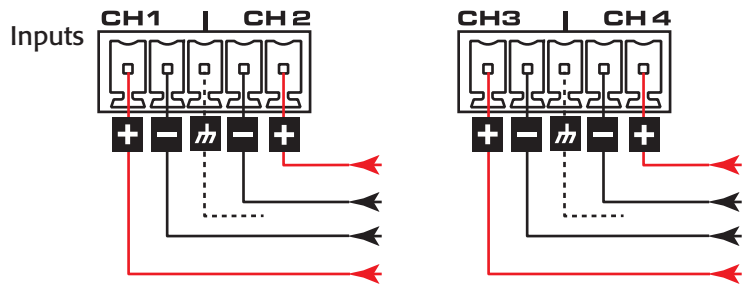

– Figure 20 –

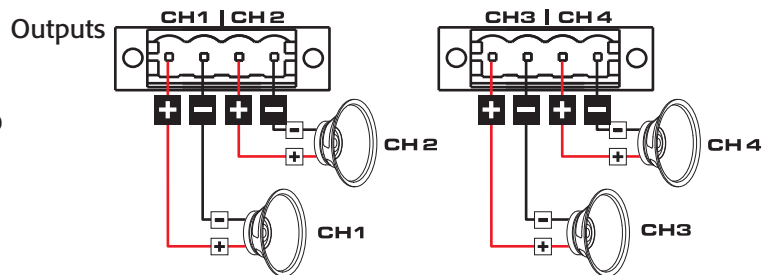

– Figure 21 –



## 4 or 8-ohm Bridged Mode

Figure 22 – Figure 24



– Figure 22 –



**CAUTION!** Do not connect any output to ground.

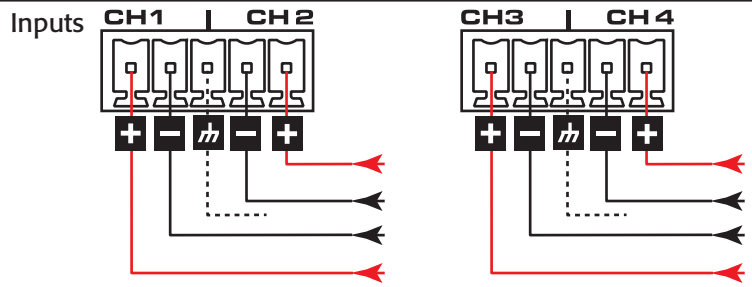

– Figure 23 –

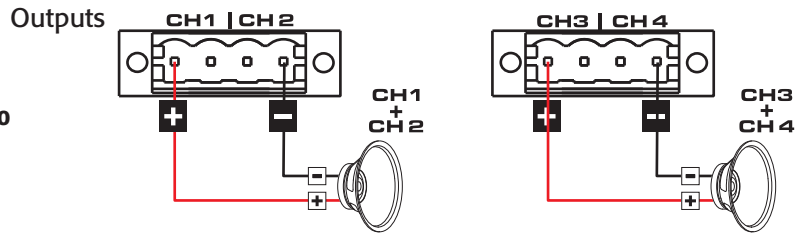

– Figure 24 –

## 70V / 100V Bridge Mode

Figure 25 – Figure 28

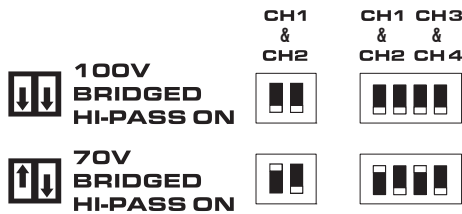

– Figure 25 –

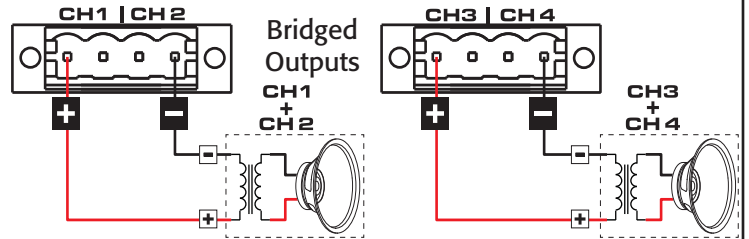

– Figure 27 –

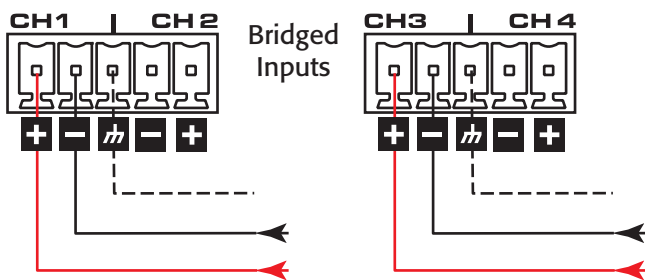

– Figure 26 –

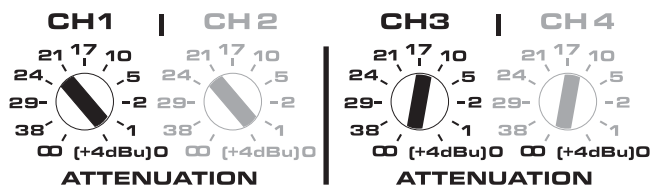

– Figure 28 –

## Remote

Figure 29 – Figure 31

### SPA2-60

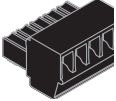
(1)  3.5mm, 5-pin

### SPA4-60

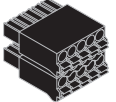
(1)  3.5mm, 10-pin

When the potentiometer is at the minimum position, the amplifier goes into Mute mode. On the SPA4-60 amplifier, the remote level controls for channel 1 & 2 are independent from channels 3 & 4 remote level control.

On the SPA4-60 model, closing the "Standby Switch" between the first two pins of either Ch1-Ch2 or Ch3-Ch4 causes all four channels to go into Standby.

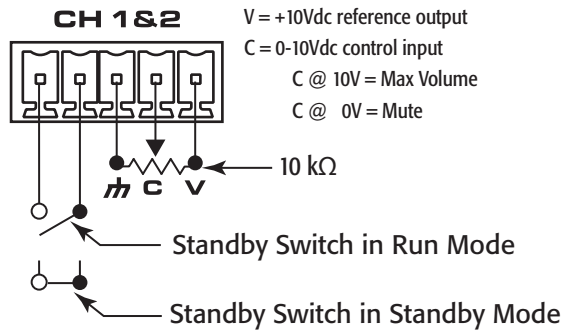

– Figure 29 –

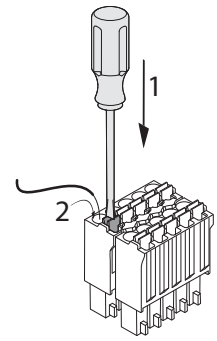

– Figure 30 –

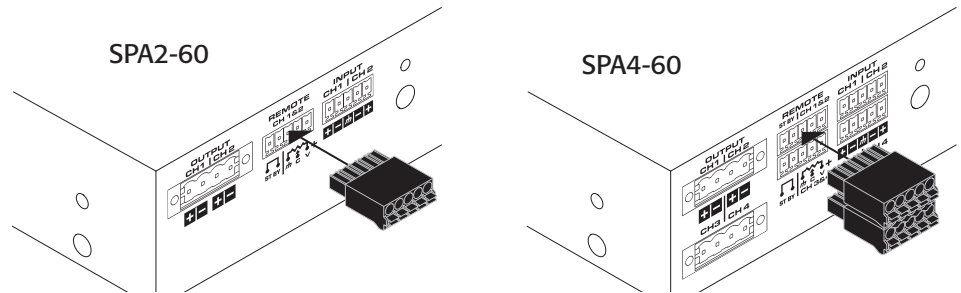

– Figure 31 –

# Specifications

Channels	
SPA2-60	2 Channels
SPA4-60	4 Channels
Stereo Mode (all channels driven)	
8 $\Omega$	60 W
4 $\Omega$	60 W
Bridged Outputs (per bridged output pair)	
8 $\Omega$ & 4 $\Omega$	200 W
70V	250 W
100V	250 W
Frequency Response (4 $\Omega$ and 8 $\Omega$ )	20 Hz - 20 kHz +/- 0.1 dB
Signal to Noise (20 Hz - 20 KHz)	>100 dB
Input Sensitivity	1.23V (+4 dBu)
Gain at 8 $\Omega$	25.0 dB
Output Circuitry	Class D
Input Impedance	>10k, balanced or unbalanced
Maximum Input Level	12.3V (+24 dBu)
Cooling	Convection
Input Connectors	
SPA2-60	3.5 mm Euro, 5 pin (green)
SPA4-60	3.5 mm Euro, 10 pin (green)
Remote Connectors	
SPA2-60	3.5 mm Euro, 5 pin (black)
SPA4-60	3.5 mm Euro, 10 pin (black)
Output Connectors	
SPA2-60	One 5 mm Euro, 4 pin (green)
SPA4-60	Two 5 mm Euro, 4 pin (green)
Front Panel Indicators	Power, Signal (per channel), Limit/Mute/Protect (per channel)
Rear Panel Indicators	Bi-Color LED Signal/Limit/Mute/Protect (per channel)
User-configurable Operating Modes (Operating mode can be independently configured per channel pair)	Low Impedance 4 $\Omega$ & 8 $\Omega$ operation, or High-impedance bridged direct drive of 70V & 100V distributed audio systems
General Purpose Inputs	Remote Volume, Remote Standby, on 3.5 mm connectors (10k potentiometer is not included)
Highpass Filter	80Hz auto-engaged in Bridged 70V & 100V modes
Dimensions	1.7" x 8.7" x 9.5" (43 mm x 220 mm x 241 mm)
Net Weight	
SPA2-60	3.5 lb (1.1 kg)
SPA4-60	4.0 lb (1.4 kg)
Shipping Weight	
SPA2-60	6 lb (2.3 kg)
SPA4-60	6.5 lb (2.5 kg)
Power Requirements	Universal Power Supply (with active power factor correction), 100 - 240 VAC, 50 - 60 Hz
Agency Approvals	UL, CE, Energy Star, RoHS/WEEE compliant, FCC Class B (Conducted and Radiated emissions), UL 2043 with PL-KIT
Carton Contents	IEC Cable, Quick Start Guide, Connector Pack, Rack Mount Ears, Mounting Brackets



Mailing Address:

QSC Audio Products, LLC  
1675 MacArthur Boulevard  
Costa Mesa, CA 92626-1468 USA

Telephone Numbers:

Main Number: (714) 754-6175  
Sales & Marketing: (714) 957-7100 or toll free (USA only) (800) 854-4079  
Customer Service: (714) 957-7150 or toll free (USA only) (800) 772-2834

Facsimile Numbers:

Sales & Marketing FAX: (714) 754-6174  
Customer Service FAX: (714) 754-6173

World Wide Web:

[www.qsc.com](http://www.qsc.com)

E-mail:

[info@qsc.com](mailto:info@qsc.com)  
[service@qsc.com](mailto:service@qsc.com)