

# MIPRO®

## Handheld Transmitter Microphone

## User Guide



ACT-30Hr

ACT-30H

**MIPRO** MIPRO Electronics Co., Ltd.

Headquarters: 814 Pei-Kang Road, Chiayi, 60096, Taiwan.

Web: [www.mipro.com.tw](http://www.mipro.com.tw)

E-mail: [mipro@mipro.com.tw](mailto:mipro@mipro.com.tw)

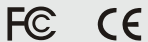

AS110930

Design and specifications are subject to change without prior notice

## Contents

- 1 Profile
- 2 Key Features
- 3 Handheld Controls and Indicators
- 5 Operating Instructions for Insertion & Removing Battery
- 6 Operating Instructions
- 7 LCD Screen
- 8 Battery Status
- 9 General Tips for Improving System Performance

## Profile

There are two types of antenna design for the handheld transmitter microphones "built-in" and "external". The "built-in" design is normally incorporate upper side of PCB in the housing and the microphone capsule module as transmitting antenna. The advantages are to avoid the antenna breakage due to external design, inconvenience and able to shorten the microphone housing design. However, its drawbacks are poor transmission efficiency especially when replacing microphone capsules, unstable and deteriorated transmission efficiency if it is gripped over the antenna area. The "external" design enhances transmission efficiency and stability, however, it causes inconvenience and it may be damaged by accidental crashing.

MIPRO's patented design provides an ideal solution. The antenna is integrated in the battery holder at the bottom side of the housing, so it successfully combines the advantages of both "built-in" and "external" design.

The matched antenna and transmitter circuit enhance transmission efficiency and stability regardless capsules and battery replacement, or change of grip positions and housing materials.

Microphone capsule, audio modulation, RF output and antenna transmission constitute the perfect straight-line layout of the transmitter PCB so that it can achieve the best transmission quality and efficiency. ACT-30H/ACT-30Hr are the most evolved design model for built-in antenna transmitters nowadays.

## Key Features

- The microphone capsule is connected to the transmitter PCB and then screwed onto the housing to prevent the potential malfunction caused by improper contact.
- Modularized PCB and microphone capsule can be easily detached and assembled. Optional premium microphone capsule modules are available.
- ACT-30H is constructed of sturdy plastic housing to enhance the transmission efficiency. Special coated treatment prevents from handling noise and paint stripping.
- ACT-30Hr is equipped with remote-control volume buttons.
- Proprietary lockable on/off switch to avoid accidental power off.
- Durable construction of integrated housing and battery compartment, allowing 2 AA type batteries easily to be inserted and replaced.
- Battery housing design secures the battery installation to prevent the malfunction when knocked. Multi-color rings for easy channel identification.
- LCD on the housing displays working group, channel, battery level and error codes.
- High-efficiency low spurious emissions UHF PLL synthesized RF technology.
- An interference-free working channel can be synchronized quickly and precisely by MIPRO's proprietary ACT function.
- MIPRO vocal condenser microphone capsule exhibits high fidelity, wide dynamic range, fast transient responses, low feedback howling, accurate sound image characteristics, transparent sound quality and extremely low handling noise.
- Proprietary high dynamic range modulation circuitry sustains a maximum SPL of 140dB so performers can be confident it won't distort when sing loudly.
- Optional MU-89b true condenser microphone capsule is ideal for natural sound reproduction.
- Built-in volume buttons in ACT-30Hr handheld transmitter enable volume loudness can be adjusted wirelessly for MIPRO MA-708 & MA-808 portable PA systems.

## Handheld Controls and Indicators

### ACT-30Hr

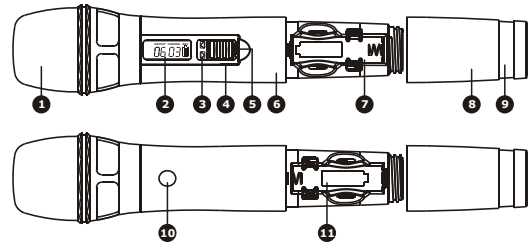

### ACT-30H

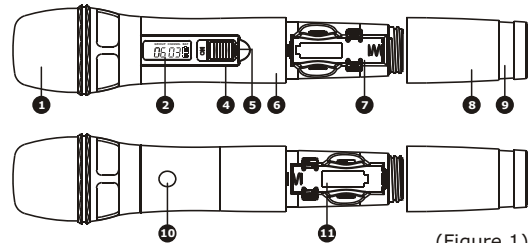

(Figure 1)

- ➊ **Top Grille:** Protects detachable microphone capsule module and internal foam prevents breathing, wind and POP noises.
- ➋ **LCD Screen:** Displays group, channel, battery status and error codes.
- ➌ **Remote Volume Control Buttons:** Press ▼ to decrease or ▲ to increase volume loudness wirelessly.
- ➍ **Power On/Off Switch:** Slide the power switch to the "ON" position for use or to the "OFF" position when not in use.

- ⑤ **Lockable On/Off Switch:** Slide the switch to the "ON" position after power-on to avoid accidental power off during performance. Slide the switch to "OFF" position before power-off and conserve battery power.
- ⑥ **Housing:** Upper portion connects to the microphone capsule module. Internally it holds the transmitter PCB and battery compartment.
- ⑦⑪ **Battery Compartment:** Accommodates 2 AA alkaline.
- ⑧ **Battery Compartment Cover:** Protects battery compartment and holds batteries.
- ⑨ **Color-Coded Ring:** Available in different colors for channel differentiation.
- ⑩ **ACT Infrared (IR) Port:** Receives signals from receiver to synchronize frequencies.

## Operating Instructions for Insertion & Removing Battery

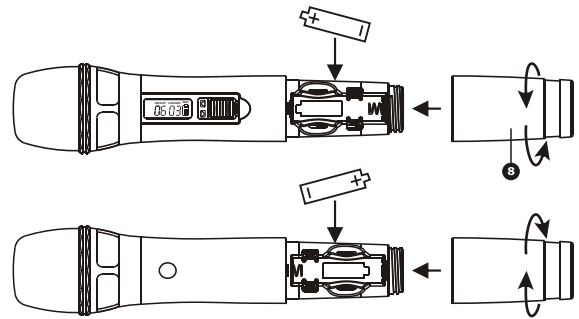

(Figure 2)

1. Gently twist the microphone housing in a counter-clockwise direction
2. Remove the old batteries from the battery compartment, if any are installed.
3. Insert two new AA alkaline batteries in the battery compartment with correct polarity orientation.

## Operating Instructions

1. LCD screen on the transmitter and the RF level/indicator shown on the receiver will be lit when the microphone is turned-on, denoting normal status. A blank LCD screen maybe due to an incorrect battery polarity orientation.
2. The audio level or indicator show on the receiver will be lit when there is audio line or microphone input from the transmitter.

## Caution

Remove the batteries if unused for a long period of time to prevent battery leakage, corrosion and causes damage to electronics.

## LCD Screen



- **ERR Message:** When "ERR" appears in the display it indicates that an operational error has occurred. Please refer to the following codes to diagnose which error you are experiencing.
  - ERR no01** EEPROM is not being programmed or internal data error.
  - ERR no02** For testing only.
  - ERR no03** The frequency you want to program is above the switching bandwidth of the transmitter. Use a receiver with an appropriate frequency group. (At this time the microphone is still operating and the frequency remains unchanged. To clear the displayed "ERR" message, switch the handheld transmitter off and on again.)
  - ERR no04** The frequency you want to program is below the switching bandwidth of the transmitter. Use a receiver with an appropriate frequency group. (At this time the microphone is still operating and the frequency remains unchanged. To clear the displayed "ERR" message, switch the handheld transmitter off and on again.)
- **"Group" & "Channel" :** When both the group and channel numbers are displayed, it means that you are using the pre-programmed frequency of the receiver.
- **"Channel" Only :** If "Channel" only is displayed, it means that you are using a frequency which is not pre-programmed.

## Battery Status

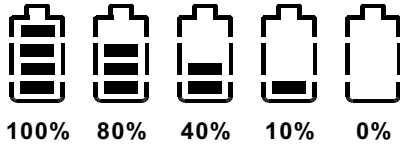

Indicates the power remaining in the transmitter battery. When the battery has less than 10% power remaining it must be replaced or recharged. If an under voltage condition continues, the LCD will show "Poff" and the system will shut down to prevent being overly discharged.

### "Poff" - Power Off :

When the power switch is turned off, the LCD will show "Poff" (for Power Off) first and then the system will shut down and no further messages will be displayed.

## General Tips for Improving System Performance

1. Performer should avoid holding the microphone over or near the antenna section as this will deteriorate transmission efficiency. Severe deterioration if performer directly covers up the antenna section with both hands.
2. Many performers tend to hold the microphone by the top grille. Unfortunately, this position seriously degrades both the sound quality and directionality of a microphone. Even the most expensive microphones will have its original sound quality compromised by this method. Grabbing a microphone by the grille will isolate the capsule's acoustic resonance circuit and or change the capsule resonator's frequency. This results in an inferior performance in both frequency response and the separation of directionality. In addition, a palm's sound-focusing effect will tend to strengthen resonances in certain frequencies and can cause unwanted echo.
3. A proper technique is required for using directional microphones because the distance between the microphone and your mouth has a significant impact on sensitivity and performance. There is an inverse relationship between microphone sensitivity and the distance from the mouth to the microphone. Consequently, performers with a "weaker" sound level cannot expect to hold the microphone too far away from their mouth and compensate by turning up the amplifier volume to increase the sound level as this can easily cause echo or feedback. In contrast, performers with a "louder" sound level should not hold the microphone too close as this can easily result in distortion by causing the amplifier system to be overloaded.

4. Furthermore, a large-diaphragm directional microphone has a very distinct proximity effect. When the microphone is close to the mouth, the bass response is strengthened as the distance gets closer. RF, if a performer's sound is insufficient in bass, they can hold the microphone closer and use the proximity effect to help compensate for the lower bass level. Conversely, if a performer's voice is too heavy in the bass register, increasing the distance between the microphone and their mouth will decrease the proximity effect and reduce the bass response, thus making their voice become clearer and brighter.
5. It is recommended to keep the grille and sponge windscreens clean to avoid any substance blocking the proximity effect of the microphone.

## FC & IC - ID

THIS DEVICE COMPLIES WITH PART 74 OF THE FCC RULES AND RSS-123 ISSUE2 OF CANADA. OPERATION IS SUBJECT TO THE FOLLOWING TWO CONDITIONS:

- (1) This device may not cause interference.
- (2) This device must accept any interference, including interference that may cause undesired operation of the device. This equipment complies with FCC RF radiation exposure limits set forth for an uncontrolled environment.

## Disposal



2005-06-13

Dispose of any unusable devices or batteries responsibly and in accordance with any applicable regulations.

Disposing of used batteries with domestic waste is to be avoided!

Batteries/NiCad cells often contain heavy metals such as cadmium(Cd), mercury(Hg) and lead(Pb) that makes them unsuitable for disposal with domestic waste. You may return spent batteries/accumulators free of charge to recycling centers or anywhere else batteries/accumulators are sold.

By doing so, you contribute to the conservation of our environment!