



TORRENT FZ



Blizzard Lighting, LLC
www.blizzardlighting.com
Waukesha, WI USA
Copyright (c) 2014

TABLE OF CONTENTS

Torrent FZ™ 300W LED Moving Head Spot	1
1. Getting Started	3
What's In The Box?	3
Getting It Out Of The Box	3
Powering Up!	3
Getting A Hold Of Us	3
Safety Instructions (Don't Stick Your Hand In The Toaster!)	4
2. Meet The Torrent FZ™ Spot	5
Features	5
DMX Quick Reference	5
The Torrent FZ Pin-up Picture	6
3. Setup	7
Fuse Replacement	7
Connecting A Bunch Of Torrent FZ's™	7
Data/DMX Cables	7
Cable Connectors	8
3-Pin??? 5-Pin??? Huh?	8
Take It To The Next Level: Setting up DMX Control	8
Fixture Linking (Master/Slave Mode)	9
Mounting/Rigging	9
4. Operating Adjustments	10
The Control Panel	10
Control Panel Menu Structure & Adjustments	11
Setting the pan/tilt to inverting or non-inverting	11
Setting the DMX channel configuration	11
Adjusting the fixture calibration	11
Resetting the fixture	11
Restoring Factory Defaults	11
Master/Slave ("Auto" or "Sound Active")	11
DMX Mode	11
Custom Programming	12
Gobo Replacement	13
DMX Channel Values In-Depth	14
Photometric Data	15
Troubleshooting	16
5. Appendix	17
A Quick DMX Lesson	17
Keeping Your Torrent FZ Spot As Good As New	18
Returns (Gasp!)	18
Shipping Issues	18
Tech Specs	19

1. GETTING STARTED

What's In The Box?

- 1 x Torrent FZ™ Spot
- An Ever-So-Handy Power Cord
- A Sweet Safety Cable & set of Mounting Brackets
- One really classy DMX cable
- This Lovely User Manual

Getting It Out Of The Box

Congratulations on purchasing the Torrent FZ™, the next generation 300-watt LED module powered zoomable beam moving head fixture of the future! Now that you've got your Torrent™ FZ (or hopefully, FZ's!), you should carefully unpack the box and check the contents to ensure that all parts are present and in good condition. If anything looks as if it has been damaged in transit, notify the shipper immediately and keep the packing material for inspection. Again, please save the carton and all packing materials. If a fixture must be returned to the factory, it is important that the fixture be returned in the original factory box and packing.

Powering Up!

All fixtures must be powered directly off a switched circuit and **cannot be run off a rheostat (variable resistor) or dimmer circuit, even if the rheostat or dimmer channel is used solely for a 0% to 100% switch.**

AC Voltage Switch - Not all fixtures have a voltage select switch, so please verify that the fixture you receive is suitable for your local power supply. See the label on the fixture or refer to the fixture's specifications chart for more information. A fixture's listed current rating is its average current draw under normal conditions. Check the fixture or device carefully to make sure that if a voltage selection switch exists that it is set to the correct line voltage you will use.

Warning! Verify that the voltage select switch on your unit matches the line voltage applied. Damage to your fixture may result if the line voltage applied does not match the voltage indicated on the voltage selector switch. All fixtures must be connected to circuits with a suitable Ground (Earthing).

Getting A Hold Of Us

If something is wrong, just give us a call or send an email. We'll be happy to help, honest.

Disclaimer: The information and specifications contained in this document are subject to change without notice. Blizzard Lighting™ assumes no responsibility or liability for any errors or omissions that may appear in this user manual. Blizzard Lighting™ reserves the right to update the existing document or to create a new document to correct any errors or omissions at any time. You can download the latest version of this document from www.blizzardlighting.com.

Author:	Date:	Last Edited:	Date:
J. Thomas	1/13/2014	J. Thomas	6/6/2016

SAFETY INSTRUCTIONS



Please read these instructions carefully. They include important information about the installation, usage and maintenance of this product.

- Please keep this User Guide for future use. If you sell the unit to someone else, be sure that they also receive this User Guide.
- ALWAYS make sure that you are connecting to the proper voltage, and that the line voltage you are connecting to is not higher than that stated on the decal or rear panel of the fixture.
- This product is intended for indoor use only.
- To prevent risk of fire or shock, do not expose fixture to rain or moisture.
- Make sure there are no flammable materials close to the unit while operating.
- The unit must be installed in a location with adequate ventilation, at least 20in (50cm) from adjacent surfaces. Be sure that no ventilation slots are blocked.
- ALWAYS disconnect from the power source before servicing or replacing fuse and be sure to replace with same fuse size and type.
- ALWAYS secure fixture using a safety chain. NEVER carry the fixture by its head. Use its carrying handles.
- DO NOT operate at ambient temperatures higher than 104°F (40°C).
- In the event of a serious operating problem, stop using the unit immediately. NEVER try to repair the unit by yourself. Repairs carried out by unskilled people can lead to damage or malfunction. Please contact the nearest authorized technical assistance center. Always use the same type spare parts.
- NEVER connect the device to a dimmer pack.
- Make sure the power cord is never crimped or damaged.
- Never disconnect the power cord by pulling or tugging on the cord.
- Avoid direct eye exposure to the light source while it is on.

Caution! There are no user serviceable parts inside the unit. Do not open the housing or attempt any repairs yourself. In the unlikely event your unit may require service, please contact Blizzard Lighting at support@blizzardlighting.com.

2. MEET THE TORRENT FZ™ SPOT

MAIN FEATURES

- 300-watt Red Butterfly LED module, 6500K CT, 50,000 hours
- 3-phase pan/tilt motors with 16-bit resolution
- Switchable 540/630 degree pan and 270 degree tilt
- 12-36 degree linear motorized zoom, motorized focus
- Completely flat beam field
- 2 gobo wheels: #1 – 7 rotating, interchangeable gobos + open, 4 glass installed, gobo size is 26.9mm outside, 21mm image. #2 – 9 metal gobos + open
- Gobo indexing for wheel #1, gobo overlay
- Color wheel: 7 colors + open, including UV
- 3 facet rotating prism
- Motorized linear iris w/pulse/burst functions
- Variable linear frost filter
- 0-100% 16-bit electronic dimmer
- 0-20Hz strobe w/random, pulse in/pulse out functions
- 15/17 channel modes plus custom design mode
- 8 built-in programs
- DMX recorder/editor built-in for standalone operation
- LCD-based menu system
- Variable speed cooling fans with smart LED protection
- ¼-turn “omega” style clamp brackets
- POWERCON-compatible power in/out

PHOTOMETRICS

- 12°: 20,180 Lux @ 2.5m, 5,250 Lux @ 5m, 2,400 Lux @ 7.5m, 1,350 Lux @ 10m
- 36°: 4,500 Lux @ 2.5m, 1,130 Lux @ 5m, 510 Lux @ 7.5m, 300 Lux @ 10m

DMX Quick Reference

Channel	Basic Mode	Channel	Standard Mode
1	Pan	1	Pan
2	Tilt	2	Pan Fine
3	Color Mode 1 or 2	3	Tilt
4	Gobo Wheel #1	4	Tilt Fine
5	Gobo Rotation	5	Color Mode 1 or 2
6	Gobo Wheel #2	6	Gobo Wheel #1
7	Shutter/Strobe	7	Gobo Rotation
8	Dimmer	8	Gobo Wheel #2
9	Focus	9	Shutter/Strobe
10	Zoom	10	Dimmer
11	Prism	11	Focus
12	Iris	12	Zoom
13	Frost	13	Prism
14	Speed	14	Iris
15	Built-in Programs	15	Frost
--	--	16	Speed
--	--	17	Built-in Programs

Figure 1: The Torrent FZ Pin-Up Picture



Figure 2: The Rear Connections



3. SETUP



Before replacing a fuse, disconnect power cord. ALWAYS replace with the same type and rating of fuse.

Fuse Replacement

With a flat head screwdriver, wedge the fuse holder out of its housing. Remove the damaged fuse from its holder and replace with exact same type fuse. Insert the fuse holder back in its place and reconnect power.

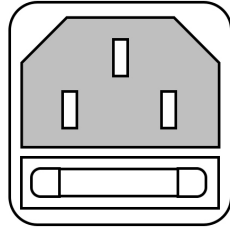

Connecting A Bunch of Torrent FZ's™

You will need a serial data link to run light shows using a DMX-512 controller or to run shows on two or more fixtures set to sync in master/slave operating mode. The combined number of channels required by all the fixtures on a serial data link determines the number of fixtures the data link can support.

Fixtures on a serial data link must be daisy chained in one single line. Also, connecting more than 32 fixtures on one serial data link without the use of a DMX optically-isolated splitter may result in deterioration of the digital DMX signal.

The maximum recommended cable-run distance is 500 meters (1640 ft). The maximum recommended number of fixtures on a serial data link is 32 fixtures.

Data/DMX Cabling

To link fixtures together you'll need data cables. You should use data-grade cables that can carry a high quality signal and are less prone to electromagnetic interference.

For instance, Belden© 9841 meets the specifications for EIA RS-485 applications. Standard microphone cables will "probably" be OK, but note that they cannot transmit DMX data as reliably over long distances. In any event, the cable should have the following characteristics:

2-conductor twisted pair plus a shield

Maximum capacitance between conductors – 30 pF/ft.

Maximum capacitance between conductor & shield – 55 pF/ft.

Maximum resistance of 20 ohms / 1000 ft.

Nominal impedance 100 – 140 ohms

Cable Connectors

Cables must have a male XLR connector on one end and a female XLR connector on the other end. (Duh!)

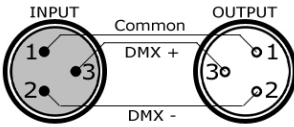

A Word on Termination: DMX is a resilient communication protocol, however errors still occasionally occur. Termination reduces signal errors, and therefore best practices include use of a terminator in all circumstances. If you are experiencing problems with erratic fixture behavior, especially over long signal cable runs, a terminator may help improve performance.

To build your own DMX Terminator:
Obtain a 120-ohm, 1/4-watt resistor, and wire it between pins 2 & 3 of the last fixture. They are also readily available from specialty retailers.

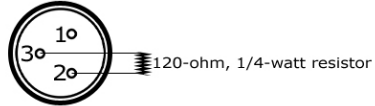

CAUTION: Do not allow contact between the common and the fixture's chassis ground. Grounding the common can cause a ground loop, and your fixture may perform erratically. Test cables with an ohm meter to verify correct polarity and to make sure the pins are not grounded or shorted to the shield or each other.

3-Pin??? 5-Pin??? Huh?!?

If you use a controller with a 5 pin DMX output connector, you will need to use a 5 pin to 3 pin adapter. They are widely available over the internet and from specialty retailers. If you'd like to build your own, the chart below details a proper cable conversion:

Conductor	3-Pin Female (Output)	5-Pin Male (Input)
Ground/Shield	Pin 1	Pin 1
DMX Data (-)	Pin 2	Pin 2
DMX Data (+)	Pin 3	Pin 3
Not Used.	No Connection.	No Connection.
Not Used.	No Connection.	No Connection.

Take It To The Next Level: Setting Up DMX Control

Step 1: Connect the male connector of the DMX cable to the female connector (output) on the controller.



Step 2: Connect the female connector of the DMX cable to the first fixture's male connector (input). *Note:* It doesn't matter which fixture address is the first one connected. We recommend connecting the fixtures in terms of their proximity to the controller, rather than connecting the lowest fixture number first, and so on.

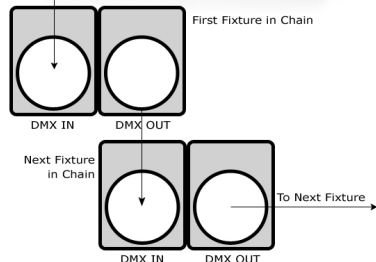

Step 3: Connect other fixtures in the chain from output to input as above. Place a DMX terminator on the output of the final fixture to ensure best communication.

Fixture Linking (Master/Slave Mode)

1. Connect the (male) 3 pin connector side of the DMX cable to the output (female) 3 pin connector of the first fixture.
2. Connect the end of the cable coming from the first fixture which will have a (female) 3 pin connector to the input connector of the next fixture consisting of a (male) 3 pin connector. Then, proceed to connect from the output as stated above to the input of the following fixture and so on.

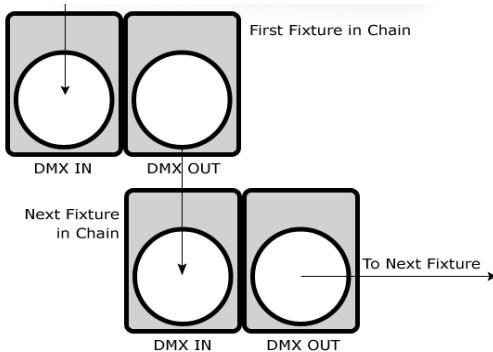

A quick note: Often, the setup for Master-Slave and Standalone operation requires that the first fixture in the chain be initialized for this purpose via either settings in the control panel or DIP-switches. Secondly, the fixtures that follow may also require a slave setting.

Check the **“Operating Adjustments”** section in this manual for complete instructions for this type of setup and configuration.

Mounting & Rigging

This fixture may be mounted in any SAFE position provided there is enough room for ventilation.

It is important never to obstruct the fan or vents pathway. Mount the fixture using a suitable “C” or “O” type clamp. The clamp should be rated to hold at least 10x the fixture’s weight to ensure structural stability. Do not mount to surfaces with unknown strength, and ensure properly “rated” rigging is used when mounting fixtures overhead.

Adjust the angle of the fixture by loosening both knobs and tilting the fixture. After finding the desired position, retighten both knobs.

- When selecting installation location, take into consideration lamp replacement access (if applicable) and routine maintenance.
- Safety cables **MUST ALWAYS** be used.
- Never mount in places where the fixture will be exposed to rain, high humidity, extreme temperature changes or restricted ventilation.

4. OPERATING ADJUSTMENTS

The Control Panel

All the goodies and different modes possible with the Torrent FZ™ are accessed by using the control panel on the front of the fixture. There are 4 control buttons below the LCD display which allow you to navigate through the various control panel menus.



Button	Function
<MODE>	Used to access the menu or to return to a previous menu option.
<UP>	Scrolls through menu options in ascending order.
<DOWN>	Scrolls through menu options in descending order.
<ENTER>	Used to select and store the current menu or option within a menu.

Access control panel functions using the four panel buttons located directly underneath the LCD Display.

The Control Panel LCD Display shows the menu items you select from the menu map on page #11. When a menu function is selected, the display will show immediately the first available option for the selected menu function. To select a menu item, press <ENTER>.

Use the <UP> and <DOWN> buttons to navigate the menu map and menu options. Press the <ENTER> button to access the menu function currently displayed or to enable a menu option. To return to the previous option or menu without changing the value, press the <MODE> button.

Control Panel Menu Structure

Main Function	Sub Function	Selection	What It Does...
DMX Address 1	N/A	= 000 <-> 255	Sets the DMX address
Auto Play 2	Auto Program	= Master = Alone	Sets the unit to run master or standalone auto programs
	Music Control	= Master = Alone	Sets the unit to run master or standalone sound active programs
Reset 3	N/A	= OFF / =ON	Resets the fixture.
Reverse Pan 4	N/A	= OFF / =ON	Reverses the fixture's Pan movement
Reverse Tilt 5	N/A	= OFF / =ON	Reverses the fixture's Tilt movement
Mic Sensitivity 6	N/A	000% <-> 100%	Adjusts the sensitivity of the fixture's internal microphone.
Special 7	1 Reset Default	= OFF / =ON	Resets all programmable settings to factory default settings.
	2 Calibration	Code = 000 <-> 255	Enters the lockout code for fixture calibration. Contact the factory for more details.
		PAN = 000 <-> 255	Adjusts the zero point for each setting to account for subtle variations from fixture to fixture, or in case recalibration becomes necessary. Each fixture is calibrated at the factory and under normal operating conditions these settings should not require adjustment.
		TILT = 000 <-> 255	
		Color Wheel = 000 <-> 255	
		Gobo Wheel = 000 <-> 255	
		Gobo Wheel 2 = 000 <-> 255	
		Dimmer = 000 <-> 255	
		Focus = 000 <-> 255	
	Prism = 000 <-> 255		
	3 Temperature	= XXXC	Displays the internal temperature at the light source.
	4 Manual Control	PAN	Allows you to manually set the fixture to a fixed setting using the DMX values for each channel. For more information on DMX values available for each channel, see pages 14-15.
		PAN-Fine	
		TILT	
		TILT-Fine	
Move Speed			
Color Wheel			
Gobo Wheel 1			
Gobo Rotation			
Gobo Wheel 2			
Strobe			
Dimmer			
Focus			
Prism			
5 Signal Set	= Wire DMX = Wireless DMX = Act WDMX & Out	Sets the DMX signal type.	
6 Color	= Color Mode 1 = Color Mode 2	Sets the current color mode.	

Control Panel Menu Structure (Continued)

Main Function	Sub Function	Selection	What It Does...
Edit Program 8	Program 1 - Program 8	Steps 000 <-> 048	Selects the number of active steps in the current program (Auto or Program 1 - 8)
		Scenes 000 <-> 048	Selects the scene for editing
		PAN	<p>Allows you to edit the pre-programmed "Auto Program" which the fixture uses in Auto and Sound active Modes using the DMX values for each channel, or edit one of 8 built in programs which are available using DMX channel #15.</p> <p>For more information on DMX values available for each channel, see pages 14-15.</p>
		PAN-Fine	
		TILT	
		TILT-Fine	
		Move Speed	
		Color Wheel	
		Gobo Wheel 1	
		Gobo Rotation	
		Gobo Wheel 2	
		Strobe	
		Dimmer	
		Focus	
		Prism	
	Iris		
	Zoom		
	Frost		
	Scene Time		
Mode of Channel 8	n/a	Standard Mode Basic Mode Extended Mode	17 channel DMX mode. 15 channel DMX mode. 17 channel DMX mode. (with customizable channel assignment)

Gobo Replacement

- 1) Remove the gobo cover by removing the four screws on the top of the fixture head.
- 2) Remove the slot-n-lock gobo from the gobo wheel by lifting up slightly and sliding it out.
- 3) Using a small tool, pry the tension ring from the gobo holder.
- 4) Remove the old gobo.
- 5) Insert the new gobo, and replace in the reverse steps of removal.

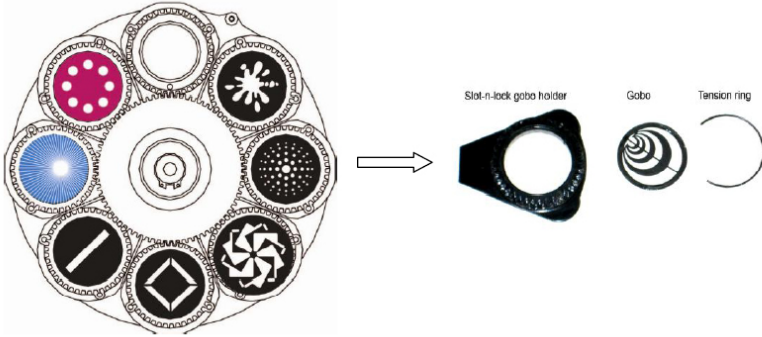

Photometric Data

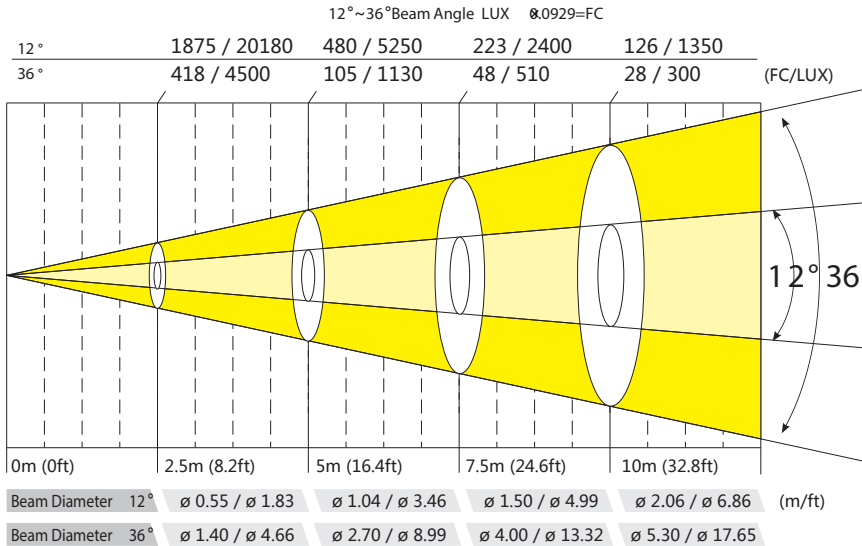

DMX Channel Value

Standard Ch. Mode	Basic Ch. Mode	Channel Value	What it does
1	1	000 <-> 255	Pan
2		000 <-> 255	Pan Fine (16-Bit Pan)
3	2	000 <-> 255	Tilt
4		000 <-> 255	Tilt Fine (16-Bit Tilt)
5	3	000 <-> 015 016 <-> 031 032 <-> 047 048 <-> 063 064 <-> 079 080 <-> 095 096 <-> 111 112 <-> 127 128 <-> 189 190 <-> 193 194 <-> 255	Color Mode 1 Open Color 1 Color 2 Color 3 Color 4 Color 5 Color 6 Color 7 Color Wheel Scroll (Clockwise, Fast <-> Slow) Stop Color Wheel Scroll (CCW, Slow <-> Fast)
5	3	000 <-> 007 008 <-> 015 016 <-> 023 024 <-> 031 032 <-> 039 040 <-> 047 048 <-> 055 056 <-> 063 064 <-> 071 072 <-> 079 080 <-> 087 088 <-> 095 096 <-> 103 104 <-> 111 112 <-> 119 120 <-> 127 128 <-> 189 190 <-> 193 194 <-> 255	Color Mode 1 Open White + Color 1 Color 1 Color 1 + Color 2 Color 2 Color 2 + Color 3 Color 3 Color 3 + Color 4 Color 4 Color 4 + Color 5 Color 5 Color 5 + Color 6 Color 6 Color 6 + Color 7 Color 7 Color 7 + White Color Wheel Scroll (Clockwise, Fast <-> Slow) Stop Color Wheel Scroll (CCW, Slow <-> Fast)
6	4	000 <-> 009 010 <-> 019 020 <-> 029 030 <-> 039 040 <-> 049 050 <-> 059 060 <-> 069 070 <-> 079 080 <-> 099 100 <-> 119 120 <-> 139 140 <-> 159 160 <-> 179 180 <-> 199 200 <-> 219 220 <-> 255	Gobo Wheel #1 Open Gobo 1 Gobo 2 Gobo 3 Gobo 4 Gobo 5 Gobo 6 Gobo 7 Gobo Shake 1 Gobo Shake 2 Gobo Shake 3 Gobo Shake 4 Gobo Shake 5 Gobo Shake 6 Gobo Shake 7 Gobo Wheel Spin (Slow <-> Fast)
7	5	000 <-> 127 028 <-> 189 190 <-> 193 194 <-> 255	Gobo Rotation Gobo Indexing Clockwise Rotation (Fast <-> Slow) Rotation Stop Counter-Clockwise Rotation (Slow <-> Fast)

DMX Channel Value (Continued)

Standard Ch. Mode	Basic Ch. Mode	Channel Value	What it does
8	6	000 <-> 009 010 <-> 019 020 <-> 029 030 <-> 039 040 <-> 049 050 <-> 059 060 <-> 069 070 <-> 079 080 <-> 089 090 <-> 099 100 <-> 111 112 <-> 123 124 <-> 135 136 <-> 147 148 <-> 159 160 <-> 171 172 <-> 183 184 <-> 195 196 <-> 207 208 <-> 255	Gobo Wheel #2 Open Gobo 1 Gobo 2 Gobo 3 Gobo 4 Gobo 5 Gobo 6 Gobo 7 Gobo 8 Gobo 9 Gobo 1 shake, slow-fast Gobo 2 shake, slow-fast Gobo 3 shake, slow-fast Gobo 4 shake, slow-fast Gobo 5 shake, slow-fast Gobo 6 shake, slow-fast Gobo 7 shake, slow-fast Gobo 8 shake, slow-fast Gobo 9 shake, slow-fast Rotate wheel clockwise, slow-fast
9	7	000 <-> 031 032 <-> 063 064 <-> 095 096 <-> 127 128 <-> 159 160 <-> 191 192 <-> 223 224 <-> 255	Strobe Closed Open Strobe (Slow <-> Fast) Open Pulse Strobe (Slow <-> Fast) Open Random Strobe (Slow <-> Fast) Open
10	8	000 <-> 255	Dimmer 0 <-> 100%
11	9	000 <-> 255	Focus Near <-> Far
12	10	000 <-> 255	Zoom Near <-> Far (12° to 36° beam angle)
13	11	000 <-> 005 006 <-> 127 128 <-> 189 190 <-> 193 193 <-> 255	Prism OFF ON Forwards rotation from fast to slow Prism rotation stop Backwards rotation from slow to fast
14	12	000 <-> 191 192 <-> 223 224 <-> 255	Iris Max. diameter to Min.diameter Pulse opening fast to slow Pulse closing slow to fast
15	13	000 <-> 191 192 <-> 223 224 <-> 254 255	Frost Frost 0 <-> 100% Pulse opening fast to slow Pulse closing slow to fast Max. Frost
16	14	000 <-> 225 226 <-> 235 236 <-> 245 246 <-> 255	Pan/Tilt Speed Fast <-> Slow Blackout by movement Blackout by all wheel change No function
17	15	000 <-> 079 080 <-> 099 100 <-> 119 120 <-> 139 140 <-> 159 160 <-> 179 180 <-> 199 200 <-> 219 220 <-> 239 240 <-> 255	Control (Hold Each for 5 Seconds to Set) No Function Motor Reset Internal Program #1 Internal Program #2 Internal Program #3 Internal Program #4 Internal Program #5 Internal Program #6 Internal Program #7 Internal Program #8

Troubleshooting

Symptom	Solution
Fixture Auto-Shut Off	Check the fan in the fixture. If it is stopped or moving slower than normal, the unit may have shut itself off due to high heat. This is to protect the fixture from overheating. Clear the fan of obstructions, or return the unit for service.
No Light Output	Check to ensure fixture is operating under correct mode, IE sound active/auto/DMX/Etc., if applicable. Contact service for more information.
No Power	Check fuse, AC cord and circuit for malfunction.
Blown Fuse	Check AC cord and circuit for damage, verify that moving parts are not restricted and that unit's ventilation is not obstructed
No Response to Audio	Verify that the fixture is in "Sound Active" mode. Adjust Audio Sensitivity, If Applicable.
Fixture Not Responding / Responding Erratically	Make sure all connectors are seated properly and securely. Use Only DMX Cables. Install a Terminator. Check all cables for defects. Reset fixture(s).
Intermittent Lamp	Check lamp for properly installation. Relamp, lamp may have reached end of life.

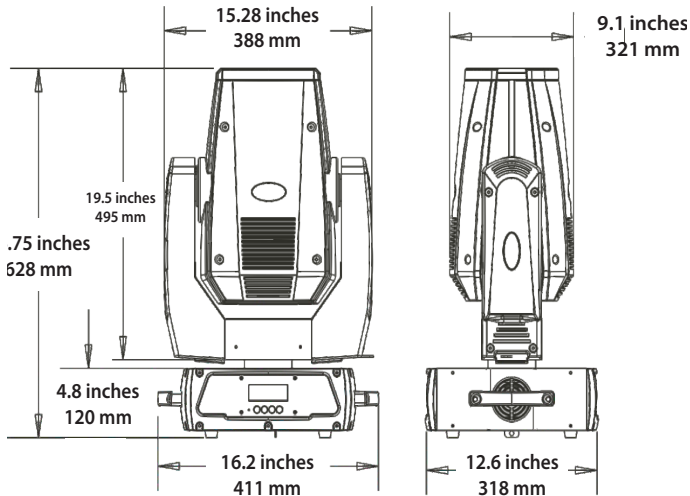

5. APPENDIX

A Quick Lesson On DMX

DMX (aka DMX-512) was created in 1986 by the United States Institute for Theatre Technology (USITT) as a standardized method for connecting lighting consoles to lighting dimmer modules. It was revised in 1990 and again in 2000 to allow more flexibility. The Entertainment Services and Technology Association (ESTA) has since assumed control over the DMX512 standard. It has also been approved and recognized for ANSI standard classification.

DMX covers (and is an abbreviation for) Digital MultipleXed signals. It is the most common communications standard used by lighting and related stage equipment.

DMX provides up to 512 control "channels" per data link. Each of these channels was originally intended to control lamp dimmer levels. You can think of it as 512 faders on a lighting console, connected to 512 light bulbs. Each slider's position is sent over the data link as an 8-bit number having a value between 0 and 255. The value 0 corresponds to the light bulb being completely off while 255 corresponds to the light bulb being fully on.

DMX data is transmitted at 250,000 bits per second using the RS-485 transmission standard over two wires. As with microphone cables, a grounded cable shield is used to prevent interference with other signals.

There are five pins on a DMX connector: a wire for ground (cable shield), two wires for "Primary" communication which goes from a DMX source to a DMX receiver, and two wires for a "Secondary" communication which goes from a DMX receiver back to a DMX source. Generally, the "Secondary" channel is not used so data flows only from sources to receivers. Hence, most of us are most familiar with DMX-512 as being employer over typical 3-pin "mic cables," although this does not conform to the defined standard.

DMX is connected using a daisy-chain configuration where the source connects to the input of the first device, the output of the first device connects to the input of the next device, and so on. The standard allows for up to 32 devices on a single DMX link.

Each receiving device typically has a means for setting the "starting channel number" that it will respond to. For example, if two 6-channel fixtures are used, the first fixture might be set to start at channel 1 so it would respond to DMX channels 1 through 6, and the next fixture would be set to start at channel 7 so it would respond to channels 7 through 12.

The greatest strength of the DMX communications protocol is that it is very simple and robust. It involves transmitting a reset condition (indicating the start of a new "packet"), a start code, and up to 512 bytes of data. Data packets are transmitted continuously. As soon as one packet is finished, another can begin with no delay if desired (usually another follows within 1 ms). If nothing is changing (i.e. no lamp levels change) the same data will be sent out over and over again. This is a great feature of DMX -- if for some reason the data is not interpreted the first time around, it will be re-sent shortly.

Not all 512 channels need to be output per packet, and in fact, it is very uncommon to find all 512 used. The fewer channels are used, the higher the "refresh" rate. It is possible to get DMX refreshes at around 1000 times per second if only 24 channels are being transmitted. If all 512 channels are being transmitted, the refresh rate is around 44 times per second.

In summary, since its design and evolution in the 1980's DMX has become the standard for lighting control. It is flexible, robust, and scalable, and its ability to control everything from dimmer packs to moving lights to foggers to lasers makes it an indispensable tool for any lighting designer or lighting performer.

Keeping Your Torrent FZ As Good As New

The fixture you've received is a rugged, tough piece of pro lighting equipment, and as long as you take care of it, it will take care of you. That said, like anything, you'll need to take care of it if you want it to operate as designed. You should absolutely keep the fixture clean, especially if you are using it in an environment with a lot of dust, fog, haze, wild animals, wild teenagers or spilled drinks.

Cleaning the optics routinely with a suitable glass cleaner will greatly improve the quality of light output. Keeping the fans free of dust and debris will keep the fixture running cool and prevent damage from overheating.

In transit, keep the fixtures in cases. You wouldn't throw a prized guitar, drumset, or other piece of expensive gear into a gear trailer without a case, and similarly, you shouldn't even think about doing it with your shiny new light fixtures.

Common sense and taking care of your fixtures will be the single biggest thing you can do to keep them running at peak performance and let you worry about designing a great light show, putting on a great concert, or maximizing your client's satisfaction and "wow factor." That's what it's all about, after all!

Returns (Gasp!)

We've taken a lot of precautions to make sure you never even have to worry about sending a defective unit back, or sending a unit in for service. But, like any complex piece of equipment designed and built by humans, once in a while, something doesn't go as planned. If you find yourself with a fixture that isn't behaving like a good little fixture should, you'll need to obtain a Return Authorization (RA).

Don't worry, this is easy. Just go to our website and open a support ticket at www.blizzardlighting.com/tickets, and we'll issue you an RA. Then, you'll need to send the unit to us using a trackable, pre-paid freight method. We suggest using USPS Priority or UPS. Make sure you carefully pack the fixture for transit, and whenever possible, use the original box & packing for shipping.

When returning your fixture for service, be sure to include the following:

- 1.) Your contact information (Name, Address, Phone Number, Email address).
- 2.) The RA# issued to you
- 3.) A brief description of the problem/symptoms.

We will, at our discretion, repair or replace the fixture. Please remember that any shipping damage which occurs in transit to us is the customer's responsibility, so pack it well!

Shipping Issues

Damage incurred in shipping is the responsibility of the shipper, and must be reported to the carrier immediately upon receipt of the items. Claims must be made within seven (7) days of receipt.

Tech Specs!

Weight & Dimensions					
Length	12.75 inches (318 mm)				
Width	16.25 inches (411 mm)				
Height	25 inches (628 mm)				
Weight	46.2 lbs (21 kg)				
Power					
Operating Voltage	90-260VAC 50/60Hz (autoranging)				
Power Consumption	390W Max.				
Light Source					
LED	1* 300w Red Butterfly LED module, 6500K CT, 50,000 hours				
Optical					
Beam Angle	12-36 degree linear motorized zoom, motorized focus				
Gobo Size	26.9mm (external dimensions), 21mm (inner dimensions)				
Luminous Intensity	Lux / meter	2.5 meters	5 meters	7.5 meters	10 meters
	12° Beam	20,180 Lux	5,250 Lux	2,400 Lux	1,350 Lux
	36° Beam	4,500 Lux	1,130 Lux	510 Lux	300 Lux
Movement Range					
Pan	540/630 degrees				
Tilt	270 degrees				
Thermal					
Max. Operating Temp.	104 degrees F (40 degrees C) ambient				
Control					
Protocol	USITT DMX-512				
DMX Channels	15/17 channel modes plus custom design mode				
Input	3-pin XLR Male				
Output	3-pin XLR Female				
Other Information					
Watch out where the huskies go, and don't you eat that yellow snow.					
Warranty	2-year limited warranty, does not cover malfunction caused by damage to LED's.				

DISCLAIMER:

The power connector fitted to the fixture and fixture cord are designed for compatibility with products manufactured by Neutrik AG, Neutrik USA and their related entities, however they are not manufactured by, affiliated with or endorsed by Neutrik AG, Neutrik USA, or any related entity. Neutrik® and powerCON® are registered trademarks of Neutrik AG.



**Enjoy your product!
Our sincerest thanks for your purchase!
--The team @ Blizzard Lighting**