



## General Description

The Rane AM1 is part gain-sharing automatic mic mixer, part manual line mixer, part USB audio I/O device, and simultaneously a Rane RAD. Use it as a standalone mic/line mixer, or add more gain-shared mics using up to seven Rane AM2 Automixers (sold separately). Use the RAD Port to transport the main mix digitally via CAT 5 to either a Rane HAL's RAD Port, or to a Rane Mongoose to a CobraNet network.

Each of the four XLR Mic Inputs offers front panel input Level controls feeding a gain-sharing automatic mixer. Rear panel, 3-position switches for each Mic Input support dynamic mics (no phantom power), condenser mics (48 V), or wireless receiver outputs (+12 dBV max). A front panel Mic Mix Level control adjusts the volume of all automixed mics.

The AM1 is optimized for automixing speech. The mic inputs have a fixed 80 Hz to 7 kHz bandpass filter to provide the best voice-only automatic mixing using a gain-sharing algorithm.

Three manually-mixed audio inputs provide a simple user interface and installation. The Aux 1 Input dual RCA and Aux 2 3.5 mm jacks are independently monoed, each with a front panel Level control. A dedicated USB Charge port adjacent to Aux 2 provides power to USB devices such as iPods or other USB-powered devices. The separate orange USB Audio Input also offers a front panel Level control for the 16-bit, 48 kHz digital audio that is monoed immediately upon entry.

Signal and Overload indicators monitor the Mic and Aux Inputs, the Mic Mix and the Main Mix. Indicators flank the corresponding Level controls.

The AM1 appears in Windows and Apple OS X computers as a standard USB Audio Device, immediately compatible with

dozens of audio recording and playback audio applications. The AM1 registers with the OS as a 16-bit 48 kHz device for both incoming and outgoing audio. The USB Audio port doubles as a firmware update port if future updates become available.

The XLR Main Output can be set to Mic- or Line-level to feed a mic snake or a +20 dBu max balanced input. The front panel Output Level control affects the XLR Output and the RAD Port output. The analog RECORD RCA Outputs and the digital USB Audio output are both mono, pre-Output Level, containing the same mix as the Main Output.

The RAD Port sends the AM1 output mix to either a Rane HAL's RAD Port for further signal processing and control, or to a Mongoose for routing to a CobraNet network. The Cascade IN accepts audio and data from a Rane AM2's Cascade OUT. This adds the AM2's eight mic channels to the AM1, creating a 12-channel gain-sharing automix. Up to seven AM2s can be cascaded to a single AM1, offering up to 60 gain-shared mics. Both the RAD and the Cascade IN port have status indicators to aid setup and troubleshooting.

Rear panel Fault, Locate, USB and Power indicators inform head-scratchers of device errors, the AM1's physical location, positive USB audio device OS registration and AC power status.

A front panel pre-Output Selector permits headphone cueing so users can verify input and output operation before bringing new sources into the live Output mix. Both ¼" & 3.5 mm headphone jacks with a Level control are provided. Duplicate Locate and Power indicators are on the front and rear.

Universal IEC power on the rear supports 100 to 240 VAC and 50/60 Hz.

## Features

### INPUTS:

- Gain-Sharing Automatic Mic Mixing:
  - 4 XLR Inputs with Level controls & Sig/OL indicators.
  - Select Mic, Mic with 48V phantom, or Line level.
- Manually Mix:
  - Overall Mic Mix.
  - Two Aux Inputs: dual RCA & 3.5 mm, independently monoed.
  - USB Audio Input (16-bit, 48 kHz).
- USB Charge Port for iPod or other USB-powered devices.
- Power, Locate, USB, Fault, and RAD status indicators.

### OUTPUTS (all mono):

- XLR Main with Mic/Line switch, Level control & Sig/OL.
- Dual RCA Record.
- Pre-Output Headphone ¼" and 3.5 mm with Level control:
  - Source select cues Mics, Aux 1, Aux 2, USB Input or Output.
- USB Audio Output (16-bit, 48 kHz).
- Rane RAD and Cascade In RJ-45 Ports:
  - Cascade In Port connects up to seven Rane AM2 Automixers.
  - RAD Port sends Output to either HAL (DSP/control) or Mongoose (CobraNet).

## Features and Specifications

<b>XLR Inputs</b>	Mono, Balanced, Mic/Line Selectable
Phantom Power	+48V per IEC 60268-15, Selectable in Mic mode
Maximum Input	-18 dBV / -6 dBV / +12 dBV (Dynamic / Condenser / Wireless)
Input Impedance	2.01k, 1%
Input Gain Range (Mic/Wireless)	-80 to +34 dB / -80 to +26 dB
Frequency Response	80 Hz to 7 kHz, +0/-3 dB, -20 dBFS, Extended vocal range
<b>Aux Inputs 1 / 2</b>	Dual Mono, Unbalanced, RCA / 3.5 mm TRS
Maximum Input	+8 dBu
Input Impedance	18.8 k $\Omega$ , 1%
Gain Range	-80 to +12 dB
Frequency Response	20 Hz to 20 kHz, +0/-0.25 dB
<b>Main Output</b>	Mono, Balanced, XLR
Maximum Output (Mic/Line)	-20 / +20 dBu, 10 k $\Omega$ load
Output Impedance (Mic/Line)	51 / 300 $\Omega$ , 1%
Output Gain Range	-80 to 0 dB
Frequency Response	23 Hz to 20.5 kHz, +0/-3 dB
Dynamic Range (Line)	101 dB re +20 dBu, 20 kHz BW, A-weighted, 0 dB gain, 10 k $\Omega$ load
THD+N	< 0.01%, 22 Hz to 20 kHz, A-weighted, +4 dBu, 0 dB gain, 10 k $\Omega$ load
<b>Record Output</b>	Dual Mono, Unbalanced, RCA
Maximum Output	+12 dBu, 10 k $\Omega$ load
Output Impedance	602 $\Omega$ , 1%
Frequency Response	23 Hz to 20.5 kHz, +0/-3 dB
Dynamic Range	101 dB re +12 dBu, 20 kHz BW, A-weighted, 0 dB gain, 10 k $\Omega$ load
THD+N	< 0.01%, 22 Hz to 20 kHz, A-weighted, +4 dBu, 0 dB gain, 10 k $\Omega$ load
<b>Headphone Output</b>	Dual Mono, Unbalanced, 1/4" and 3.5mm TRS
Maximum Output	+9 dBu, 150 $\Omega$ load
Maximum Output Power	30 mW into 150 $\Omega$
Output Gain Range	-63 to +16 dB
Frequency Response	23 Hz to 20.5 kHz, +0/-3 dB
Dynamic Range	101 dB re +9 dBu, 20Hz to 20 kHz BW, A-weighted, 0 dB Gain, 150 $\Omega$ load
THD+N	< 0.06%, 22 Hz to 20 kHz, A-weighted, +4 dBu, 0 dB gain, 150 $\Omega$ load
<b>LED Meters</b>	Mono, peak detecting
Signal	-50 dBFS, Green LED, Peak-Reading
Overload	-0.5 dBFS, Red LED, Peak-Reading
<b>RAD / Cascade In</b>	8P8C (RJ-45) Connector
Sample Rate and Resolution	48 kHz @ 24 bits
<b>USB Digital Audio</b>	Dual Mono In/Out, USB-B connector
Sample Rate and Resolution	48 kHz @ 16 bits
<b>USB Charge Only Port</b>	USB-A Connector
Output Voltage and Current	+5 V max @ +500 mA max
<b>Latency</b>	From analog input to analog output on a single AM1 (or AM2), latency is 1.45 ms.
Additional Cascaded AM2s	Each additional AM2 adds another 0.75 ms to the initial 1.45 stated above.
<b>Unit</b>	All Steel Construction
Universal Line Voltage	100 to 240 VAC, 50/60 Hz, 13 W
Conformity	CE, FCC, cCSAus
U.S. Patent No. 8,542,849	
Size	1U 1.75"H x 19"W x 8.5"D (4.4 cm x 48.3 cm x 21.6 cm)
Weight	5 lb 4 oz (2.4 kg)
Shipping Size	4.5" x 20.3" x 13.75" (11.5 cm x 52 cm x 35 cm)
Shipping Weight	9 lb (4.1 kg)
<i>Note: 0 dBu = 0.775 Vrms</i>	

## Block Diagram

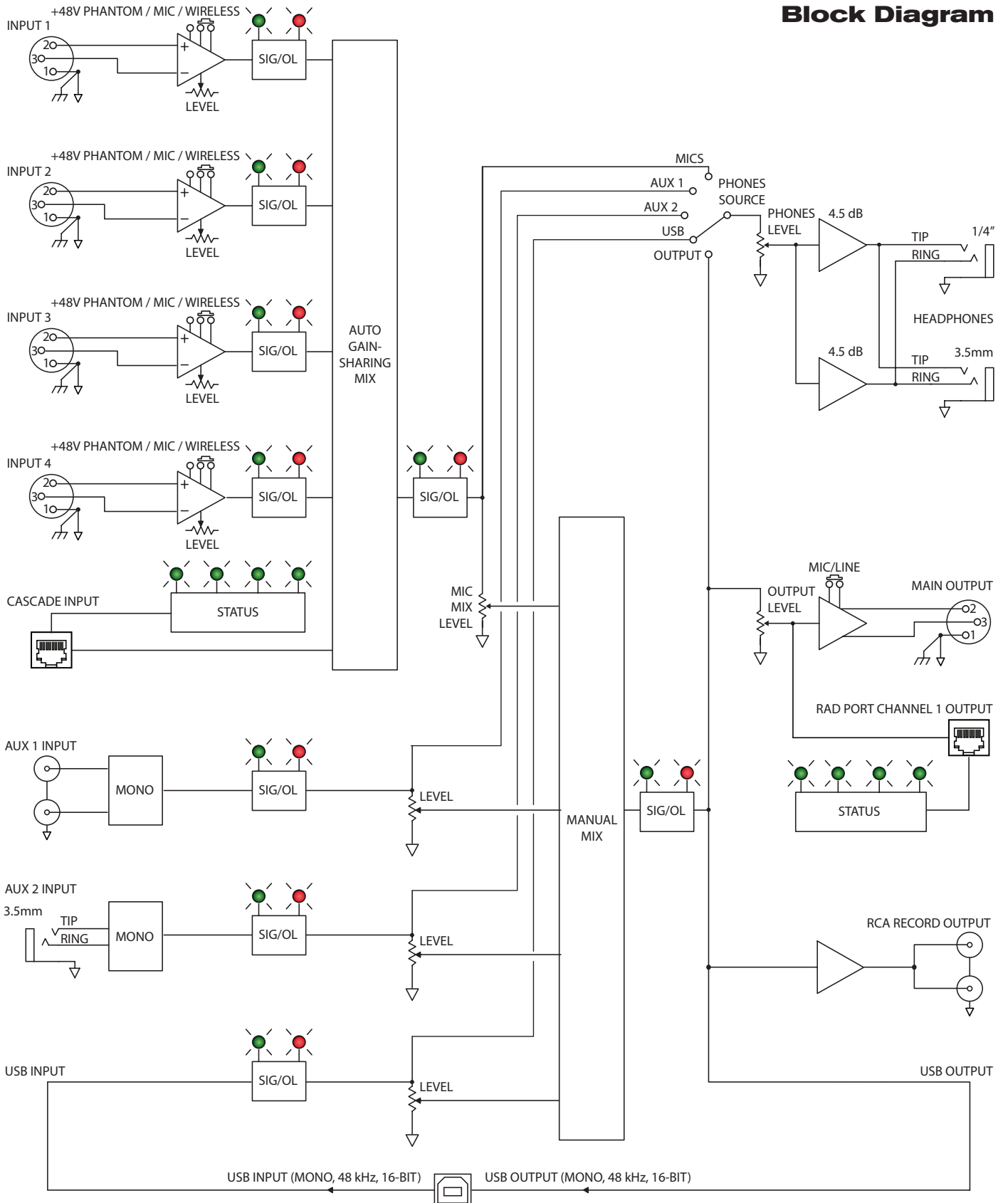

# AM1 AUTOMIXER



## Applications

- AV Rental Systems
- Auditoriums
- Conference Centers
- Houses of Worship
- Hotels
- School AV Nerds
- Panel Discussions
- Podcasting

Facilities and rental agencies are called upon to provide either equipment, or equipment and operators, for meetings or conferences needing A/V support. The equipment providers must ensure audio quality throughout the event to get repeat business. However, the provided equipment may be operated by presenters who have no audio experience. If an operator is sent with the equipment to set up and manage the system during the presentation, that operator may have little audio experience. Pitfalls abound when interconnecting the system, and managing multi-microphone gain before feedback, mixing and volume. Handling iPod and laptop playback and/or recording adds even more complexity. Enter the Rane AM1.

The AM1 makes it easy for an inexperienced operator to quickly set up and manage audio for a multimedia presentation involving up to four participants with microphones (wired or wireless) and several program audio sources (e.g., DVD, Laptop, MP3 player).

The AM1 offers a professional integrated solution that provides superior automatic gain before feedback while eliminating operator error with simple controls. The microphone gain-sharing algorithm automatically and appropriately attenuates mics not in use while maintaining the 3 dB per doubling of mics for different (noncoherent) talkers, and 6 dB per doubling for the same (coherent) talker who is directly between two mics. Appropriately, line audio sources are manually mixed since there is no acoustic feedback potential. The AM1's flexible line input combination of RCA, 3.5 mm and separate USB Charge and Audio I/O ports makes integration and cabling easy. And since the USB Audio port can simultaneously playback audio and record the AM1's output, the same laptop can be a source and a recording device to document AV meetings, presentations, trainings, and family karaoke nights for AV contractor employees.

### AM1 use with HAL

The AM1 is a RAD allowing its manually created mono mix to be sent digitally to a Rane HAL's RAD port via a CAT 5 cable. Once the AM1 mix is in the HAL DSP, additional signal processing such as EQ and compression can be added. Control of the mix's level using Rane's DR1 or DR3 Digital Remotes is a breeze.



It is not possible to cascade the AM1 mix into Halogen's Gain-Sharing Auto Mixer or Room Combine Processor. You must use the AM2 mixer for cascading with these DSP blocks.

## Example AM1 System

