

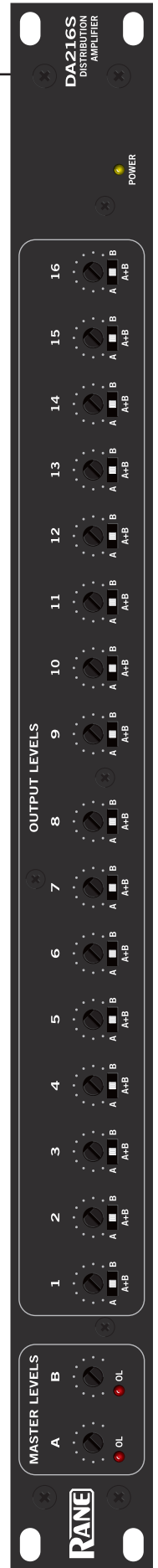

DA216S

DISTRIBUTION AMPLIFIER



CONTENTS *(in order of appearance)*

- Important Safety Instructions
- DA216S Manual
- DA216S Data Sheet
- Sound System Interconnection
- Rane Professional Install Products
- Schematics
- Warranty
- Declaration of Conformity

IMPORTANT SAFETY INSTRUCTIONS



1. Read these instructions.
 2. Keep these instructions.
 3. Heed all warnings.
 4. Follow all instructions.
 5. Do not use this apparatus near water.
 6. Clean only with a dry cloth.
 7. Do not block any ventilation openings. Install in accordance with manufacturer's instructions.
 8. Do not install near any heat sources such as radiators, registers, stoves, or other apparatus (including amplifiers) that produce heat.
 9. Do not defeat the safety purpose of the polarized or grounding-type plug. A polarized plug has two blades with one wider than the other. A grounding-type plug has two blades and a third grounding prong. The wide blade or third prong is provided for your safety. If the provided plug does not fit into your outlet, consult an electrician for replacement of the obsolete outlet.
 10. Protect the power cord and plug from being walked on or pinched particularly at plugs, convenience receptacles, and the point where it exits from the apparatus.
 11. Only use attachments and accessories specified by Rane.
 12. Use only with the cart, stand, tripod, bracket, or table specified by the manufacturer, or sold with the apparatus. When a cart is used, use caution when moving the cart/apparatus combination to avoid injury from tip-over.
 13. Unplug this apparatus during lightning storms or when unused for long periods of time.
 14. Refer all servicing to qualified service personnel. Servicing is required when the apparatus has been damaged in any way, such as power supply cord or plug is damaged, liquid has been spilled or objects have fallen into the apparatus, the apparatus has been exposed to rain or moisture, does not operate normally, or has been dropped.
 15. The plug on the power cord is the AC mains disconnect device and must remain readily operable. To completely disconnect this apparatus from the AC mains, disconnect the power supply cord plug from the AC receptacle.
 16. This apparatus shall be connected to a mains socket outlet with a protective earthing connection.
 17. When permanently connected, an all-pole mains switch with a contact separation of at least 3 mm in each pole shall be incorporated in the electrical installation of the building.
 18. If rackmounting, provide adequate ventilation. Equipment may be located above or below this apparatus, but some equipment (like large power amplifiers) may cause an unacceptable amount of hum or may generate too much heat and degrade the performance of this apparatus.
 19. This apparatus may be installed in an industry standard equipment rack. Use screws through all mounting holes to provide the best support.
- WARNING:** To reduce the risk of fire or electric shock, do not expose this apparatus to rain or moisture. Apparatus shall not be exposed to dripping or splashing and no objects filled with liquids, such as vases, shall be placed on the apparatus.

WARNING



To reduce the risk of electrical shock, do not open the unit. No user serviceable parts inside. Refer servicing to qualified service personnel.

The symbols shown below are internationally accepted symbols that warn of potential hazards with electrical products.



This symbol indicates that a dangerous voltage constituting a risk of electric shock is present within this unit.



This symbol indicates that there are important operating and maintenance instructions in the literature accompanying this unit.

WARNING: This product may contain chemicals known to the State of California to cause cancer, or birth defects or other reproductive harm.

NOTE: This equipment has been tested and found to comply with the limits for a Class B digital device, pursuant to part 15 of the FCC Rules. These limits are designed to provide reasonable protection against harmful interference in a residential installation. This equipment generates, uses and can radiate radio frequency energy and, if not installed and used in accordance with the instructions, may cause harmful interference to radio communications. However, there is no guarantee that interference will not occur in a particular installation. If this equipment does cause harmful interference to radio or television reception, which can be determined by turning the equipment off and on, the user is encouraged to try to correct the interference by one or more of the following measures:

- Reorient or relocate the receiving antenna.
- Increase the separation between the equipment and receiver.
- Connect the equipment into an outlet on a circuit different from that to which the receiver is connected.
- Consult the dealer or an experienced radio/TV technician for help.

CAUTION: Changes or modifications not expressly approved by Rane Corporation could void the user's authority to operate the equipment.

INSTRUCTIONS DE SÉCURITÉ



1. Lisez ces instructions.
2. Gardez précieusement ces instructions.
3. Respectez les avertissements.
4. Suivez toutes les instructions.
5. Ne pas utiliser près d'une source d'eau.
6. Ne nettoyer qu'avec un chiffon doux.
7. N'obstruer aucune évacuation d'air. Effectuez l'installation en suivant les instructions du fabricant.
8. Ne pas disposer près d'une source de chaleur, c-à-d tout appareil produisant de la chaleur sans exception.
9. Ne pas modifier le cordon d'alimentation. Un cordon polarisé possède 2 lames, l'une plus large que l'autre. Un cordon avec tresse de masse possède 2 lames plus une 3^e pour la terre. La lame large ou la tresse de masse assurent votre sécurité. Si le cordon fourni ne correspond pas à votre prise, contactez votre électricien.
10. Faites en sorte que le cordon ne soit pas piétiné, ni au niveau du fil, ni au niveau de ses broches, ni au niveau des connecteurs de vos appareils.
11. N'utilisez que des accessoires recommandés par Rane.
12. N'utilisez que les éléments de transport, stands, pieds ou tables spécifiés par le fabricant ou vendu avec l'appareil. Quand vous utilisez une valise de transport, prenez soin de vous déplacer avec cet équipement avec prudence afin d'éviter tout risque de blessure.
13. Débranchez cet appareil pendant un orage ou si vous ne l'utilisez pas pendant un certain temps.
14. Adressez-vous à du personnel qualifié pour tout service après vente. Celui-ci est nécessaire dans n'importe quel cas où l'appareil est abîmé : si le cordon ou les fiches sont endommagés, si du liquide a été renversé ou si des objets sont tombés sur l'appareil, si celui-ci a été exposé à la pluie ou l'humidité, s'il ne fonctionne pas correctement ou est tombé.
15. La fiche du cordon d'alimentation sert à brancher le courant alternatif AC et doit absolument rester accessible. Pour déconnecter totalement l'appareil du secteur, débranchez le câble d'alimentation de la prise secteur.
16. Cet appareil doit être branché à une prise terre avec protection.
17. Quand il est branché de manière permanente, un disjoncteur tripolaire normalisé doit être incorporé dans l'installation électrique de l'immeuble.
18. En cas de montage en rack, laissez un espace suffisant pour la ventilation. Vous pouvez disposer d'autres appareils au-dessus ou en-dessous de celui-ci, mais certains (tels que de gros amplificateurs) peuvent provoquer un buzz ou générer trop de chaleur au risque d'endommager votre appareil et dégrader ses performances.
19. Cet appareil peut-être installé dans une baie standard ou un châssis normalisé pour un montage en rack. Visser chaque trou de chaque oreille de rack pour une meilleure fixation et sécurité.

ATTENTION: afin d'éviter tout risque de feu ou de choc électrique, gardez cet appareil éloigné de toute source d'humidité et d'éclaboussures quelles qu'elles soient. L'appareil doit également être éloigné de tout objet possédant du liquide (boisson en bouteilles, vases,...).

ATTENTION



Afin d'éviter tout risque de choc électrique, ne pas ouvrir l'appareil. Aucune pièce ne peut être changée par l'utilisateur. Contactez un SAV qualifié pour toute intervention.

Les symboles ci-dessous sont reconnus internationalement comme prévenant tout risque électrique.



Ce symbole indique que cette unité utilise un voltage élevé constituant un risque de choc électrique.



Ce symbole indique la présence d'instructions d'utilisation et de maintenance importantes dans le document fourni.

REMARQUE: Cet équipement a été testé et approuvé conforme aux limites pour un appareil numérique de classe B, conformément au chapitre 15 des règles de la FCC. Ces limites sont établis pour fournir une protection raisonnable contre tout risque d'interférences et peuvent provoquer une énergie de radiofréquence s'il n'est pas installé et utilisé conformément aux instructions, peut également provoquer des interférences aux niveaux des équipements de communication. Cependant, il n'existe aucune garantie que de telles interférences ne se produiront pas dans une installation particulière. Si cet équipement provoque des interférences en réception radio ou télévision, ceci peut être détecté en mettant l'équipement sous/hors tension, l'utilisateur est encouragé à essayer de corriger cette interférence par une ou plusieurs des mesures suivantes:

- Réorienter ou déplacer l'antenne de réception.
- Augmenter la distance entre l'équipement et le récepteur.
- Connecter l'équipement à une sortie sur un circuit différent de celui sur lequel le récepteur est branché.
- Consulter un revendeur ou un technicien radio / TV expérimenté.

ATTENTION: Les changements ou modifications non expressément approuvés par Rane Corporation peuvent annuler l'autorité de l'utilisateur à manipuler cet équipement et rendre ainsi nulles toutes les conditions de garantie.

CAN ICES-3 (B)/NMB-3(B)



Cartons et papier à recycler.

RANE

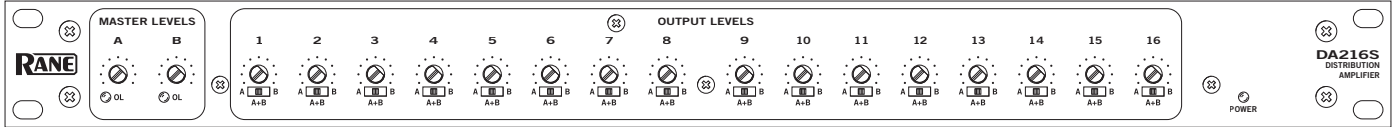

Quick Start

This section is for those that just can't wait to get started. This Distribution Amplifier has a powerful feature not found on most DA's – **Output assignment switches**. If your application calls for a single channel set-up with one Input driving all Outputs, set all of the switches to the appropriate Input (**A** or **B**). To mix both inputs, set them all to **A+B**. In this mode, both Inputs drive all Outputs with the Inputs summed. The **MASTER LEVEL** controls set the input level. *Occasionally blinking OL* indicators are okay. The individual **OUTPUT LEVEL** controls set the level for each Output channel.

For a stereo application, decide how the stereo Outputs are to be assigned and set the assignment switches accordingly. Eight stereo outputs are possible.

Set the back panel switches for either **LINE** or **MIC** Inputs. When using microphones that require a “phantom” voltage, turn

on the **PHANTOM POWER** switch, illuminating its rear panel LED. Because the phantom voltage is applied to both Inputs, don't mix phantom powered and non-phantom powered mics in the same DA216S. *Never engage the phantom voltage when using an unbalanced mic*—doing so may damage the mic. If the mic is too “hot”, press the **INPUT GAIN** switch *in* to reduce the gain by 20 dB. Incidentally, the **INPUT PAD** switch reduces the gain 40 dB when in the **LINE** position (pressed *in*). When using the Inputs for line-level, pressing in both the **INPUT PAD** and the **INPUT GAIN** switches provides a nominal gain of 0 dB. An additional 16 dB of gain is available when both the **MASTER LEVEL** and **OUTPUT LEVEL** controls are turned all the way up (clockwise).

The internal universal supply allows operation in almost any part of the world. All that is required in different countries is the correct IEC line cord.

DA216S Front Panel

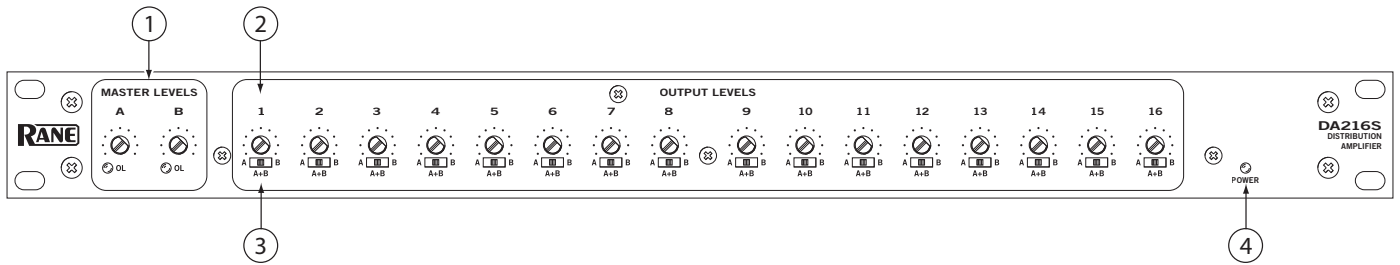

- ① **MASTER LEVELS:** These screwdriver adjustable controls set the level of each Input to be routed to bus A, B, or A+B. The Overload (OL) LEDs illuminate whenever either Input section (both pre-gain and post-gain) approach clipping. Each MASTER LEVEL may be adjusted from *off* to +10 dB gain.
- ② **OUTPUT LEVEL controls:** Each Output channel has an independent LEVEL control. Each Output may be adjusted from *off* to +6 dB gain.
- ③ **Output Assign switches:** Each switch has three positions, which assign the Output to the A-Input, the B-Input, or A+B (sum). This powerful feature allows the DA216S distribution amplifier to be set up as 1 Input to 16 Outputs. Or 1 stereo Input pair to 8 stereo Output pairs. Or 1 Input to 3 Outputs, with the other Input to 13 Outputs. And so on. For those of you that like impressive numbers, that amounts to 43,046,721 possible combinations (3^{16})! Go ahead – count them. By the way, for those that really like this stuff, if we allow turning the gain all the way down on any Output as part of the combination, the number jumps to 4,294,967,295 (4^{16}). Fortunately, most users will only be concerned with one or two of these possibilities.
- ④ **POWER Indicator:** When this yellow LED is illuminated power is running through the DA216S.

DA216S Rear Panel

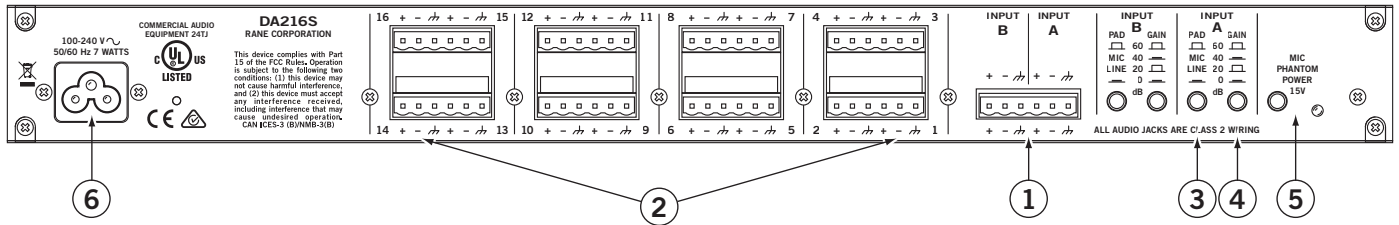

- ① **INPUT Euroblocks:** Attach either Microphone or Line-level sources here. Euroblocks accept any #14 to #26 gauge wire. Connect balanced sources to the respective “+” and “-” terminals, and tie the shield to chassis ground. For unbalanced sources use two-conductor shielded cable as described in *DA216S Connection* on page Manual-4.
- ② **Output Euroblocks 1-16:** Balanced Outputs are provided for each of 16 channels. Connect two conductor shielded cable to “+” and “-” terminals, and connect the shield to the ground terminal. For unbalanced use, do not connect “-” to chassis ground. See the *Outputs* section on page Manual-4.
- ③ **INPUT PAD switches:** In the MIC position (*out*), the gain is appropriate for a microphone Input (40 dB or 60 dB). In the LINE position (*in*), the gain is line-level (0 dB or 20 dB). When this switch is in the LINE position, PHANTOM POWER (⑤) for the channel is disabled.
- ④ **INPUT GAIN switches:** Changes the gain by 20 dB. That is, with mic Input, the INPUT GAIN switch sets the gain to 60 dB (*out*) or 40 dB (*in*). With a line-level Input, it sets the gain to 20 dB (*out*) or 0 dB (*in*).
- ⑤ **PHANTOM POWER switch:** When activated (*in*), 15 VDC Phantom Power appears at each mic-level Input and the LED illuminates. If an Input is selected for line-level, the Phantom Voltage is disabled for that channel, even when the PHANTOM LED is lit.
- ⑥ **Power connector:** The internal universal switching power supply operates on any AC mains 100 to 240 VAC, 50 or 60 Hz (most places in the world). All that is required when traveling is the appropriate IEC line cord.

DA216S Connection

When connecting the DA216S to other components in your system, leave the power supply for last. This gives you a chance to make mistakes and correct them without announcing what you did to the whole world and without damaging “downstream” equipment. Remember this when setting INPUT PAD, INPUT GAIN and PHANTOM POWER switches. These switches should never be changed in a live system. Suddenly changing the gain by 40 dB can have a profound impact on the ears of the listening audience.

INPUTS

The two Inputs on the DA216S are balanced. They may also be used in an unbalanced configuration. However, if used unbalanced, *do not engage Phantom Power*. Use only shielded cable for the Inputs. This cable should always be two conductors plus shield, even for unbalanced operation. If you *must* use shielded single conductor, keep the cable as short as possible (under 10 feet [3 meters]) to avoid hum or radio pick up.

When connecting Inputs, use all three Input terminals. For unbalanced, the “hot” Input goes to the “+”, and the common wire goes to the “-” while the shield connects the ground. Since the common wire and shield are to be tied together at one end in an unbalanced system, this connects the “-” Input to chassis ground. In a balanced system (highly preferred), the “+” Input connects to the “+” Output of the previous equipment. The “-” Input then connects to the “-” Output and the shield goes to the chassis ground. These Input connections may be reversed if it is necessary to reverse the polarity of the Input signal.

Be aware, if a microphone is used which requires Phantom Power, the shield must be connected to chassis ground to complete the Phantom Power circuit. Remember, a dynamic mic will likely be damaged if used unbalanced while the Phantom Power is turned on. At the very least, it will saturate the mic’s output transformer and spoil the sound quality. With the INPUT PAD switched to LINE, Phantom Power is disabled for that Input only. That is, a balanced, Phantom Powered mic may be used at one Input and a line input at the other without problems.

See the RaneNote “Sound System Interconnection” for additional information on grounding and shielding.

OUTPUTS

The DA216S’s Outputs are balanced and quite substantial. They will easily drive long cables and 600 Ω loads to full level. The same wiring conventions as the Inputs apply. For unbalanced Outputs, “hot” goes to the “+”, and the shield connects to chassis ground. When wiring unbalanced Outputs, do *not* tie the unused terminal (normally “-”) to Ground — leave it floating.

32 Unbalanced Outputs Tip: *The (“-”) Output may also be used as an unbalanced line driver, albeit inverted. The balanced Input terminals of the next stage must be reversed (+) for (-) to correct for the inversion. This nets a total of 32 Outputs!*

Operating Instructions

Using the 3-position Output Assign switches, select either the A Input, the B Input, or A+B Inputs. If the sum of both Inputs is selected, but only one Input is driven, the Output is reduced by 6 dB compared to the Output being assigned to only the driven Input. Since normally the Output would be assigned to both Inputs only if both Inputs are driven, this isn’t usually an issue. With the sum of the Inputs available in this way, the DA216S may be used as a two-input mixer with 16 assignable Outputs. Each Output has an independent Gain control which ranges from *off* to +6 dB gain in the output stage. Coupled with a maximum gain of +10 dB for the MASTER LEVEL controls, a total of +16 dB gain is available with the OUTPUT LEVEL controls. The INPUT GAIN switch provides for an additional 20 dB gain increase.

MIC-LEVEL

For optimum noise performance with microphones, obtain as much gain as possible in the Input stage of the DA216S without overdriving the unit.

1. Set the appropriate INPUT PAD switch to MIC (*out*).
2. Set the appropriate INPUT GAIN switch to 40 dB (*in*).
3. Set the MASTER LEVEL controls fully counterclockwise.
4. Set the OUTPUT LEVEL controls midway.

5. Adjust the MASTER LEVEL clockwise until the OL LED just blinks on the loudest expected program material. If the MASTER LEVEL is turned all the way up and the OL LED is not lighting, set the INPUT GAIN to 60 dB and adjust the MASTER LEVEL again. Adjust the OUTPUT LEVELs for the desired output level. If the OL LED is *not* lit, adjusting the OUTPUT LEVEL cannot cause clipping within the DA216S. The user may still want to turn down the OUTPUT LEVEL to avoid overloading downstream equipment.

LINE-LEVEL

In the LINE-level configuration, start with unity gain.

1. Set INPUT PAD switch to LINE position (*in*).
2. Set appropriate INPUT GAIN switch to 0 dB.
3. Set MASTER LEVEL controls fully counterclockwise.
4. Set OUTPUT LEVEL controls midway.

5. Adjust the MASTER LEVEL clockwise until the OL LED just blinks on the loudest expected program material. If the MASTER LEVEL is turned all the way up and the OL LED never comes on, set the INPUT GAIN switch *out* to the 20 dB position. Adjust the MASTER LEVEL control as before for optimum gain, then adjust the OUTPUT LEVEL controls for the desired output level.

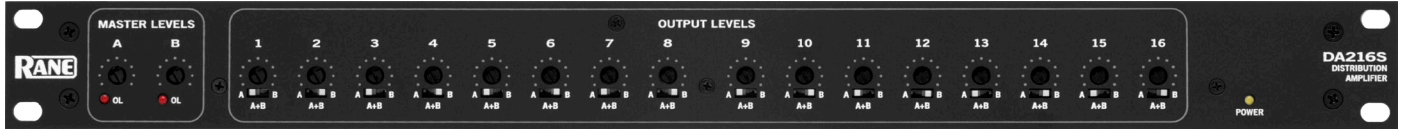

General Description

The Rane DA216S Distribution Amplifier is a two-input, sixteen-output splitter/distribution amplifier. The DA216S is capable of providing sixteen discrete balanced outputs from one or two balanced mic-level or line-level inputs. The level of each output is individually adjusted via one of the sixteen screwdriver Output Level controls on the front panel. *Each output may be assigned to either or both inputs via front panel accessible slide switches.*

The Master A and B Level controls affect the overall level of each input. In other words, they allow all assigned outputs to be turned up or down at once. LEDs indicate an Overload (OL) at either the inputs or at the internal gain stages.

Each input is set to either Mic or Line level via the rear panel Input Pad pushbutton. The separate Input Gain pushbutton

switches provide a microphone input with +60 or +40 dB of gain, or a line input with +20 or 0 dB of gain. With Input Gain, Master Levels and Output Levels, any reasonable input signal may be adjusted to a nominal +4 dBu and still have 17 dB of headroom. The Phantom Power switch provides +15 VDC for condenser microphones. *Any input assigned to line-level has this phantom voltage turned off automatically.* A rear-panel LED indicates when the Phantom Power is engaged.

Each output stage incorporates a high-current balanced output line driver for driving long lines with optimal performance.

The DA216S improves on the previous DA 216 model with an internal universal voltage power supply, operable nearly anywhere in the world (100-240 VAC).

Features

- A, B, A&B Output Assign Switches
- Sixteen Balanced (Terminal) Outputs, Individually Assignable
- Two Balanced Inputs
- Studio Grade Low Noise Input Amp
- Input Overload Indicators
- Mic/Line Input Switches
- Gain Switches: 40/60 dB Mic, 0/20 dB Line
- Phantom Power Switch
- Master Input and Individual Output Level Controls
- Stable High-Current Line Drivers
- All Outputs Capable of Driving 600Ω Loads Simultaneously
- UL/CSA/CE Internal Universal Power Supply (100-240 VAC)

Features and Specifications

Parameter	Specification	Limit	Units	Conditions/Comments
Mic Input Impedance	1.82k	1%	Ω	Balanced 909 + 909
Line Input Impedance	17.9k	1%	Ω	Balanced 8.97k + 8.97k
Mic Gain Control	+40 & +60	±2	dB	2-position switch
Mic Pad	20	±2	dB	2-position switch
Line Gain Range	0 & +20	±2	dB	2-position switch
Overall Mic Gain	+56 & +76	±4	dB	All controls maximum
Overall Line Gain	+16 & +36	±4	dB	All controls maximum
Max Mic Input Level	-20	typ	dBu	Gain at 40 dB
Max Line Input Level	+21	typ	dBu	Gain at 0 dB
Overload LED	3 dB below clip	typ		Clip defined as 1% THD+N
Phantom Power	+15	±0.5	VDC	Phantom Power switch active
Output Impedance	200	1%	Ω	Balanced 100+100
Output Drive Level	+24	typ	dBu	600 Ω load
Output Cable Length	1500	max	feet	Belden 8451 or equivalent
Mic Equivalent Input Noise	-128	typ	dBu	Rs=150, gain=60 dB
Line Signal-To-Noise Ratio	100	min	dBV	gain=0 dB, re +4 dBu, 22 kHz BW
THD+Noise (Line Input)	0.005	typ	%	gain=0 dB, +4 dBu@1 kHz, 80 kHz BW
Frequency Response, Line	15-50 kHz	+0, -3	dB	0 dB Gain, 0 dBu Output
Frequency Response, Mic	15-50 kHz	+0, -3	dB	40 dB Gain, 0 dBu Output
Frequency Response, Mic	30-50 kHz	+0, -3	dB	60 dB Gain, 0 dBu Output
Crosstalk	80	typ	dB	+4 dBu Output, 1 kHz
Power Supply Requirement	100 to 240	10%	VAC	50/60 Hz, 7W
Unit: Conformity	CE, FCC, cULus			
Unit: Construction	All Steel			
.....Size	1.75"H x 19"W x 5.3"D (1U)			(4.4 cm x 48.3 cm x 13.3 cm)
.....Weight	4 lb			(1.9 kg)
Shipping: Size	4.25" x 20.3" x 13.75"			(11 cm x 52 cm x 35 cm)
.....Weight	7 lb			(3.2 kg)
<i>Note: 0 dBu=0.775 Vrms</i>				

Block Diagram

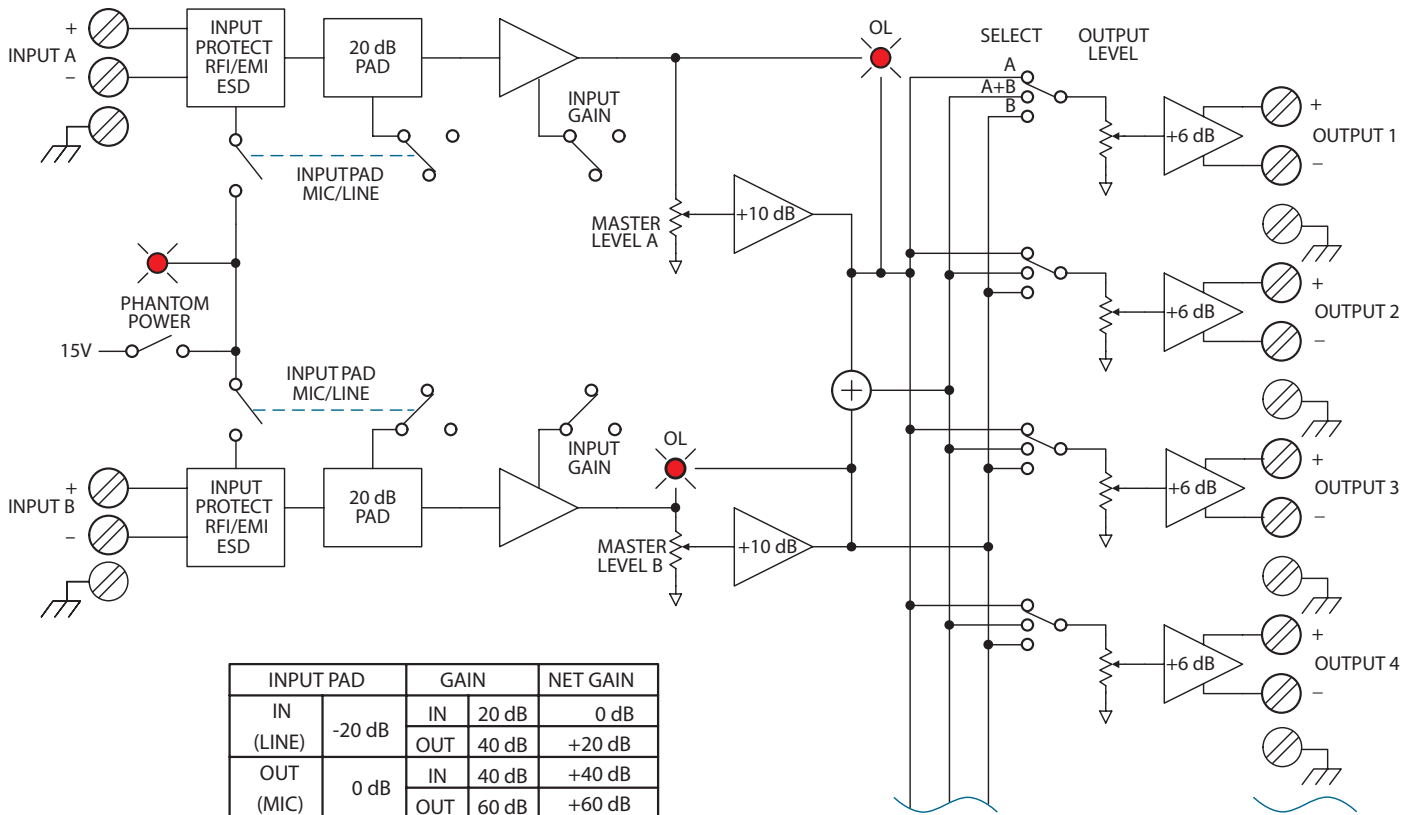

TO OUTPUTS 5 - 16

Applications

Use of the DA216S is straightforward. Connect balanced inputs and outputs to the Euroblocks, following the silk-screened labels. Wire range is #14 to #26 stranded or solid.

The diagram above shows the uncomplicated nature. Fully balanced low-noise mic preamplifiers receive the signal to be split or distributed. The Input Pad pushbuttons change the input gain range. Additional Gain pushbuttons increase either Mic or Line level inputs another +20 dB (see table above).

Keep an eye on the Overload indicators when setting the gain. Always use the most gain possible without causing the Overload indicator to light. Occasional flickering is permitted. Setting gain this way maintains the best signal-to-noise performance for the system. The Master Level controls allow level matching and balancing as required.

When operating unbalanced, a 6 dB loss of signal must be taken into account when setting the gain structure of the system. *When wiring an Output for unbalanced operation do not ground the unused terminal (i.e. usually the "-"). Unbalanced uses only the "+" and ground terminals.*

Application Example

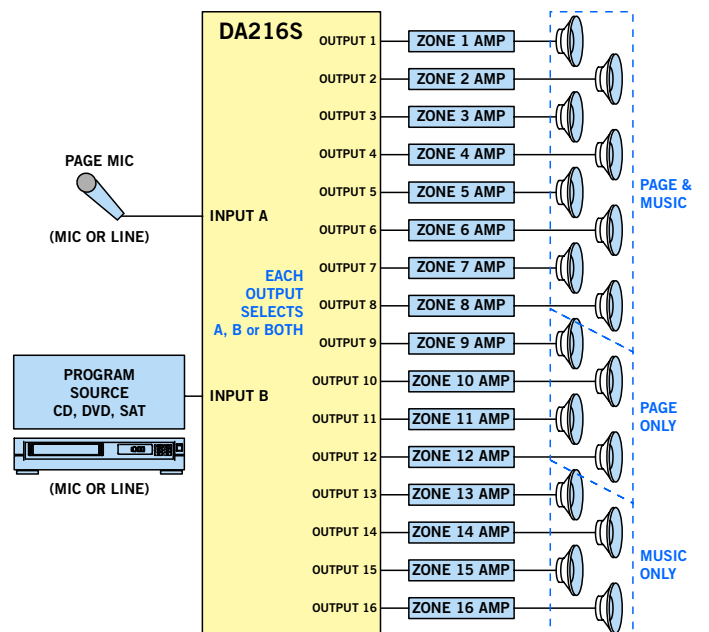

DA216S

DISTRIBUTION AMPLIFIER



Rear Panel

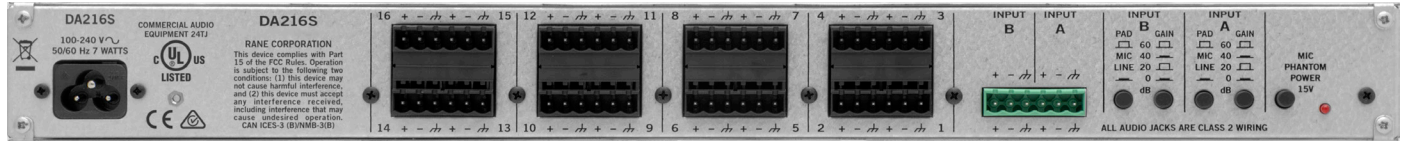

32 Unbalanced Outputs

The (“-”) Output may also be used as an unbalanced line driver, albeit inverted. The balanced Input terminals of the next stage must be reversed (+) for (-) to correct for the inversion. This nets a total of 32 Outputs! However, the penalty for 32 outputs is that unbalanced operation will not drive long lines and individual control is lost.

Architectural Specifications

The distribution amplifier shall have two (2) inputs and sixteen (16) outputs. The unit shall be capable of mono (16 mono outputs) or stereo operation (8 stereo outputs) via front panel switches. Each output shall be assignable to either or both of the master inputs.

Each input shall be microphone or line level switchable by means of rear panel switches. Additional 20 dB gain switches shall be built-in for each input, applicable to either a mic or line level signal. Each input shall have a front panel screwdriver level adjustment. 15V phantom power shall be provided via a rear panel switch for microphone inputs.

Each output shall have a front panel screwdriver adjustment. Inputs and outputs shall be active balanced screw terminal connectors.

The unit shall be capable of operation by means of its own built-in universal power supply operating at 100-240 VAC and meet CE requirements. The unit shall be UL and cUL listed. The unit shall be entirely constructed from cold-rolled steel.

The unit shall be a Rane DA216S Distribution Amplifier.

Sound System Interconnection

- Cause & prevention of ground loops
- Interfacing balanced & unbalanced
- Proper pin connections and wiring
- Chassis ground vs. signal ground
- Ground lift switches

Rane Technical Staff

RaneNote 110

© 1985, 1995, 2006, 2007, 2011, 2015 Rane Corporation

Introduction

This note, originally written in 1985, continues to be one of our most useful references. It's popularity stems from the continual and perpetual difficulty of hooking up audio equipment without suffering through all sorts of bizarre noises, hums, buzzes, whistles, etc.— not to mention the extreme financial, physical and psychological price. As technology progresses it is inevitable that electronic equipment and its wiring should be subject to constant improvement. Many things *have* improved in the audio industry since 1985, but unfortunately wiring isn't one of them. However, finally the Audio Engineering Society (AES) has issued a standards document for interconnection of pro audio equipment. It is AES48, titled "AES48-2005: AES standard on interconnections —Grounding and EMC practices — Shields of connectors in audio equipment containing active circuitry."

Rane's policy is to accommodate rather than dictate. However, this document contains suggestions for external wiring changes that should ideally only be implemented by trained technical personnel. Safety regulations require that all original grounding means provided from the factory be left intact for safe operation. No guarantee of responsibility for incidental or consequential damages can be provided. *(In other words, don't modify cables, or try your own version of grounding unless you really understand exactly what type of output and input you have to connect.)*

Ground Loops

Almost all cases of noise can be traced directly to ground loops, grounding or lack thereof. It is important to understand the mechanism that causes grounding noise in order to effectively eliminate it. Each component of a sound system produces its own ground internally. This ground is usually called the audio *signal* ground. Connecting devices together with the interconnecting cables can tie the signal grounds of the two units together in one place through the conductors in the cable. Ground loops occur when the grounds of the two units are also tied together in another place: via the third wire in the line cord, by tying the metal chassis together through the rack rails, etc. These situations create a circuit through which current may flow in a closed “loop” from one unit’s ground out to a second unit and back to the first. It is not simply the presence of this current that creates the hum—it is when this current flows through a unit’s audio signal ground that creates the hum. In fact, even without a ground loop, a little noise current always flows through every interconnecting cable (i.e., it is impossible to eliminate these currents entirely). The mere presence of this ground loop current is no cause for alarm if your system uses properly implemented and *completely* balanced interconnects, which are excellent at rejecting ground loop and other noise currents. Balanced interconnect was developed to be immune to these noise currents, which can never be entirely eliminated. What makes a ground loop current annoying is when the audio signal is affected. Unfortunately, many manufacturers of balanced audio equipment design the internal grounding system improperly, thus creating balanced equipment that is not immune to the cabling’s noise currents. This is one reason for the bad reputation sometimes given to balanced interconnect.

A second reason for balanced interconnect’s bad reputation comes from those who think connecting unbalanced equipment into “superior” balanced equipment should improve things. Sorry. Balanced interconnect is not compat-

ible with unbalanced. The small physical nature and short cable runs of completely unbalanced systems (home audio) also contain these ground loop noise currents. However, the currents in unbalanced systems never get large enough to affect the audio to the point where it is a nuisance. Mixing balanced and unbalanced equipment, however, is an entirely different story, since balanced and unbalanced interconnect are truly *not compatible*. The rest of this note shows several recommended implementations for all of these interconnection schemes.

The potential or voltage which pushes these noise currents through the circuit is developed between the independent grounds of the two or more units in the system. The impedance of this circuit is low, and even though the voltage is low, the current is high, thanks to Mr. Ohm, without whose help we wouldn’t have these problems. It would take a very high resolution ohm meter to measure the impedance of the steel chassis or the rack rails. We’re talking thousandths of an ohm. So trying to measure this stuff won’t necessarily help you. We just thought we’d warn you.

The Absolute Best Right Way To Do It

The method specified by AES48 is to use balanced lines and *tie the cable shield to the metal chassis (right where it enters the chassis) at both ends of the cable*.

A balanced line requires three separate conductors, two of which are signal (+ and –) and one shield (see Figure 1a). The shield serves to guard the sensitive audio lines from interference. Only by using balanced line interconnects can you *guarantee* (yes, *guarantee*) hum-free results. Always use twisted pair cable. Chassis tying the shield at each end also *guarantees* the best possible protection from RFI [radio frequency interference] and other noises [neon signs, lighting dimmers].

Neil Muncy¹, an electroacoustic consultant and seasoned veteran of years of successful system design, chairs the AES

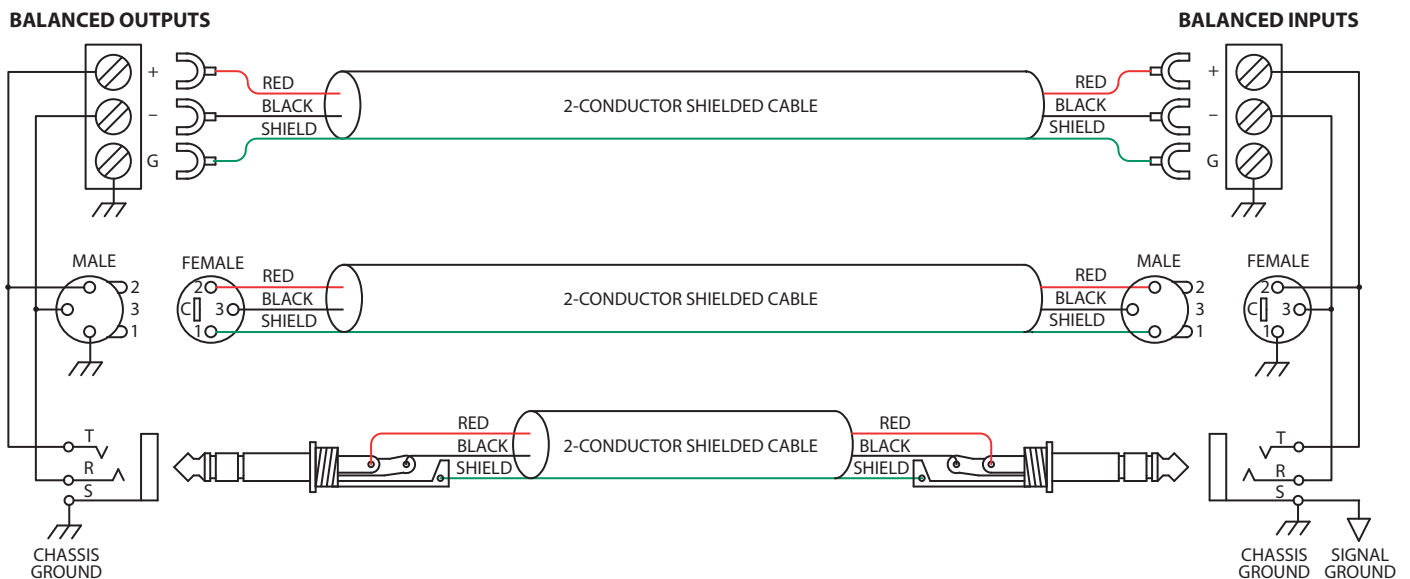

Figure 1a. The right way to do it.

Standards Committee (SC-05-05) working on this subject. He tirelessly tours the world giving seminars and dispensing information on how to successfully hook-up pro audio equipment². He makes the simple point that it is absurd that you cannot go out and buy pro audio equipment from several different manufacturers, buy standard off-the-shelf cable assemblies, come home, hook it all up and have it work hum and noise free. *Plug and play*. Sadly, almost never is this the case, despite the science and rules of noise-free interconnect known and documented for over 60 years (see References for complete information).

It all boils down to using balanced lines, only balanced lines, and nothing but balanced lines. This is why they were developed. Further, that you *tie the shield to the chassis, at the point it enters the chassis, and at both ends of the cable* (more on 'both ends' later).

Since standard XLR cables come with their shields tied to pin 1 at each end (the shells are not tied, nor need be), this means equipment using 3-pin, XLR-type connectors *must tie pin 1 to the chassis* (usually called chassis ground) — not the audio signal ground as is most common.

Not using *signal ground* is the most radical departure from common pro-audio practice. Not that there is any argument about its validity. There isn't. **This is the right way to do it.** So why doesn't audio equipment come wired this way? Well, some does, and since 1993, more of it does. That's when Rane started manufacturing some of its products with balanced inputs and outputs tying pin 1 to chassis. So why doesn't everyone do it this way? Because life is messy, some things are hard to change, and there will always be equipment in use that was made before proper grounding practices were in effect.

Unbalanced equipment is another problem: it is everywhere, easily available and inexpensive. All those RCA and 1/4" TS connectors found on consumer equipment; effect-loops and insert-points on consoles; signal processing boxes; semi-pro digital and analog tape recorders; computer cards; mixing consoles; et cetera.

The next several pages give tips on how to successfully address hooking up unbalanced equipment. Unbalanced equipment when "blindly" connected with fully balanced units starts a pattern of hum and undesirable operation, requiring extra measures to correct the situation.

COMMON (WRONG) PRACTICE

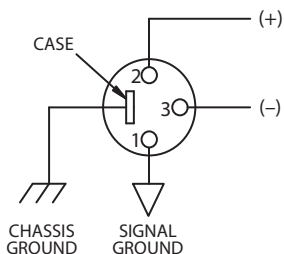

RECOMMENDED PRACTICE

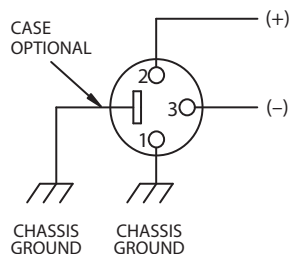

Figure 1b. Recommended practice.

The Next Best Right Way To Do It

The quickest, quietest and most foolproof method to connect balanced and unbalanced is to **transformer isolate all unbalanced connections**. See Figure 2.

Many manufacturers provide several tools for this task, including Rane. Consult your audio dealer to explore the options available.

The goal of these adaptors is to allow the use of *standard cables*. With these transformer isolation boxes, modification of cable assemblies is unnecessary. Virtually any two pieces of audio equipment can be successfully interfaced without risk of unwanted hum and noise.

Another way to create the necessary isolation is to use a *direct box*. Originally named for its use to convert the high impedance, high level output of an electric guitar to the low impedance, low level input of a recording console, it allowed the player to plug "directly" into the console. Now this term is commonly used to describe any box used to convert unbalanced lines to balanced lines.

The Last Best Right Way To Do It

If transformer isolation is not an option, special cable assemblies are a last resort. The key here is to prevent the shield currents from flowing into a unit whose grounding scheme creates ground loops (hum) in the audio path (i.e., most audio equipment).

It is true that connecting both ends of the shield is theoretically the best way to interconnect equipment — though this assumes the interconnected equipment is internally grounded properly. Since most equipment is *not* internally grounded properly, connecting both ends of the shield is not often practiced, since doing so usually creates noisy interconnections.

A common solution to these noisy hum and buzz problems involves disconnecting one end of the shield, even though one can not buy off-the-shelf cables with the shield disconnected at one end. The best end to disconnect is the receiving end. If one end of the shield is disconnected, the noisy hum current stops flowing and away goes the hum — but only at low frequencies. A ground-sending-end-only shield connection minimizes the possibility of high frequency (radio) interference since it prevents the shield from acting as an antenna to the next input. Many reduce this potential RF interference by providing an RF path through

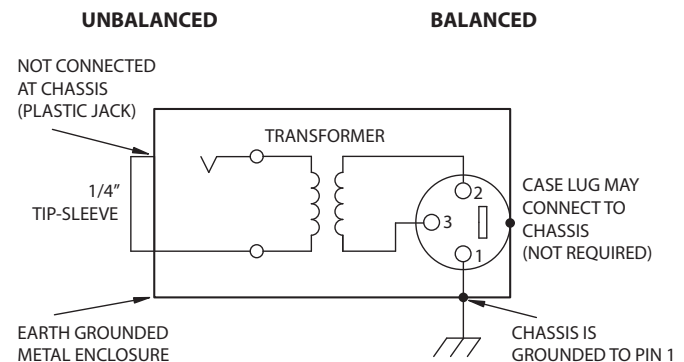

Figure 2. Transformer Isolation

a small capacitor (0.1 or 0.01 microfarad ceramic disc) connected from the lifted end of the shield to the chassis. (This is referred to as the “hybrid shield termination” where the sending end is bonded to the chassis and the receiving end is capacitively coupled. See Neutrik’s EMC-XLR for example.) The fact that many modern day installers still follow this one-end-only rule with consistent success indicates this and other acceptable solutions to RF issues exist, though the increasing use of digital and wireless technology greatly increases the possibility of future RF problems.

If you’ve truly isolated your hum problem to a specific unit, chances are, even though the documentation indicates proper chassis grounded shields, the suspect unit is not internally grounded properly. Here is where special test cable assemblies, shown in Figure 3, really come in handy. These assemblies allow you to connect the shield to chassis ground *at the point of entry*, or to pin 1, or to lift one end of the shield. The task becomes more difficult when the unit you’ve isolated has multiple inputs and outputs. On a suspect unit with multiple cables, try various configurations on each connection to find out if special cable assemblies are needed at more than one point.

See Figure 4 for suggested cable assemblies for your particular interconnection needs. Find the appropriate output configuration (down the left side) and then match this with the correct input configuration (across the top of the page.) Then refer to the following pages for a recommended wiring diagram.

Ground Lifts

Many units come equipped with ground lift switches. In only a few cases can it be shown that a ground lift switch improves ground related noise. (Has a ground lift switch ever *really* worked for you?) In reality, the presence of a ground lift switch greatly reduces a unit’s ability to be “properly” grounded and therefore immune to ground loop hums and buzzes. Ground lifts are simply another Band-Aid to try in case of grounding problems. It is true that an entire system of properly grounded equipment, without ground lift switches, is guaranteed (yes *guaranteed*) to be hum free. The problem is most equipment is *not* (both internally and externally, AC system wise) grounded properly.

Most units with ground lifts are shipped so the unit is “grounded” — meaning the chassis is connected to audio signal ground. (This should be the best and is the “safest” position for a ground lift switch.) If after hooking up your system it exhibits excessive hum or buzzing, there is an incompatibility somewhere in the system’s grounding configuration. In addition to these special cable assemblies that may help, here are some more things to try:

1. Try combinations of lifting grounds on units supplied with lift switches (or links). It is wise to do this with the power off!
2. If you have an entirely balanced system, verify all chassis are tied to a good earth ground, for safety’s sake and hum protection. Completely unbalanced systems never earth ground anything (except cable TV, often a ground loop source). If you have a mixed balanced and unbalanced system, do yourself a favor and use isolation transformers or, if you can’t do that, try the special cable assemblies described here and expect it to take many hours to get things quiet. May the Force be with you.
3. Balanced units with outboard power supplies (wall warts or “bumps” in the line cord) do *not* ground the chassis through the line cord. Make sure such units are solidly grounded by tying the chassis to an earth ground using a star washer for a reliable contact. (Rane always provides this chassis point as an external screw with a toothed washer.) Any device with a 3-prong AC plug, such as an amplifier, may serve as an earth ground point. Rack rails may or may not serve this purpose depending on screw locations and paint jobs.

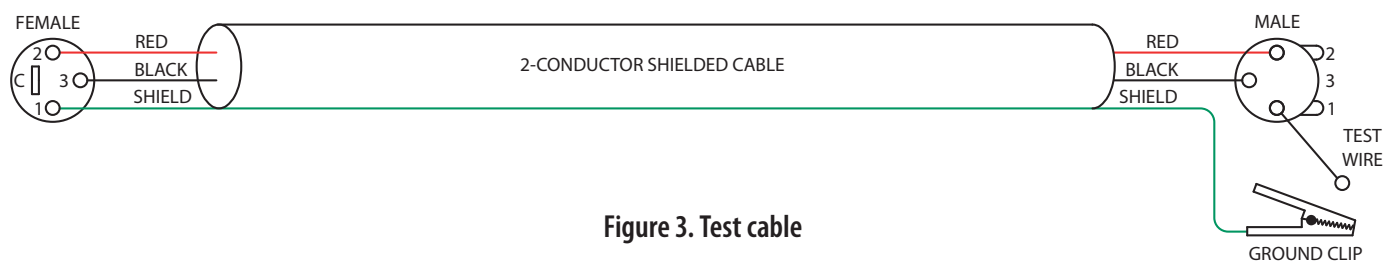

Figure 3. Test cable

Floating, Pseudo, and Quasi-Balancing

During inspection, you may run across a ¼" output called floating unbalanced, sometimes also called pseudo-balanced or quasi-balanced. In this configuration, the sleeve of the output stage is not connected inside the unit and the ring is connected (usually through a small resistor) to the audio signal ground. This allows the tip and ring to “appear” as an equal impedance, not-quite balanced output stage, even though the output circuitry is unbalanced.

Floating unbalanced often works to drive either a balanced or unbalanced input, depending if a TS or TRS standard cable is plugged into it. When it hums, a special cable is required. See drawings #11 and #12, and do not make the cross-coupled modification of tying the ring and sleeve together.

Winning the Wiring Wars

- Use balanced connections whenever possible, with the shield bonded to the metal chassis at both ends.
- Transformer isolate all unbalanced connections from balanced connections.
- Use special cable assemblies when unbalanced lines cannot be transformer isolated.
- Any unbalanced cable must be kept under 10 feet (3 m) in length. Lengths longer than this will amplify all the nasty side effects of unbalanced circuitry's ground loops.

Summary

If you are unable to do things correctly (i.e. use fully balanced wiring with shields tied to the *chassis* at both ends, or transformer isolate all unbalanced signals from balanced signals) then there is no guarantee that a hum-free interconnect can be achieved, nor is there a definite scheme that will assure noise-free operation in all configurations.

References

1. Neil A. Muncy, “Noise Susceptibility in Analog and Digital Signal Processing Systems,” presented at the 97th AES Convention of Audio Engineering Society in San Francisco, CA, Nov. 1994.
2. *Grounding, Shielding, and Interconnections in Analog & Digital Signal Processing Systems: Understanding the Basics*; Workshops designed and presented by Neil Muncy and Cal Perkins, at the 97th AES Convention of Audio Engineering Society in San Francisco, CA, Nov. 1994.
3. The entire June 1995 AES Journal, Vol. 43, No. 6, available \$6 members, \$11 nonmembers from the Audio Engineering Society, 60 E. 42nd St., New York, NY, 10165-2520.
4. Phillip Giddings, *Audio System Design and Installation* (SAMS, Indiana, 1990).
5. Ralph Morrison, *Noise and Other Interfering Signals* (Wiley, New York, 1992).
6. Henry W. Ott, *Noise Reduction Techniques in Electronic Systems*, 2nd Edition (Wiley, New York, 1988).
7. Cal Perkins, “Measurement Techniques for Debugging Electronic Systems and Their Instrumentation,” *The Proceedings of the 11th International AES Conference: Audio Test & Measurement*, Portland, OR, May 1992, pp. 82-92 (Audio Engineering Society, New York, 1992).
8. Macatee, *RaneNote*: “Grounding and Shielding Audio Devices,” Rane Corporation, 1994.
9. Philip Giddings, “Grounding and Shielding for Sound and Video,” *S&VC*, Sept. 20th, 1995.
10. AES48-2005: *AES standard on interconnections — Grounding and EMC practices — Shields of connectors in audio equipment containing active circuitry* (Audio Engineering Society, New York, 2005).

Band-Aid is a registered trademark of Johnson & Johnson

To Input







From Output	CABLE CONNECTORS					
		MALE BALANCED XLR	¼" BALANCED TRS (TIP-RING-SLEEVE)	¼" OR 3.5mm UNBALANCED TS (TIP-SLEEVE)	UNBALANCED RCA	BALANCED EUROBLOCK
	 FEMALE BALANCED XLR (NOT A TRANSFORMER, NOR A CROSS-COUPLED OUTPUT STAGE)	1	2	3_B	4_B	+ to + - to - SHIELD NC
	 FEMALE BALANCED XLR (EITHER A TRANSFORMER OR A CROSS-COUPLED OUTPUT STAGE)	1	2	5	6	+ to + - to - SHIELD NC
	 ¼" BALANCED TRS (NOT A TRANSFORMER, NOR A CROSS-COUPLED OUTPUT STAGE)	7	8	9_B	10_B	+ to + - to - SHIELD ONLY TO EUROBLOCK
	 ¼" BALANCED TRS (EITHER A TRANSFORMER OR A CROSS-COUPLED OUTPUT STAGE)	7	8	11	12	+ to + - to - SHIELD NC
	 ¼" FLOATING UNBALANCED TRS (TIP-RING-SLEEVE) (SLEEVE IN UNIT = NC)	21_A	22_A	11	12	+ to + - to - GROUND to GROUND
	 ¼" OR 3.5 mm UNBALANCED TS (TIP-SLEEVE)	13	14	15_A	16_A	23
	 UNBALANCED RCA (TIP-SLEEVE)	17	18	19_A	20_A	23
	 BALANCED EUROBLOCK	+ to + - to - SHIELD ONLY TO XLR PIN 1	+ to + - to - SHIELD ONLY TO TRS SLEEVE	24	24	+ to + - to - GROUND to GROUND

Figure 4. Interconnect chart for locating correct cable assemblies on the following pages.

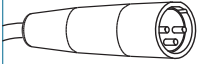
Note: (A) This configuration uses an "off-the-shelf" cable.

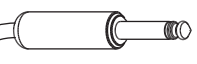
Note: (B) This configuration causes a 6 dB signal loss. Compensate by "turning the system up" 6 dB.

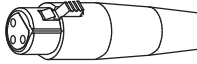
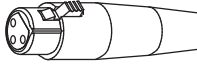
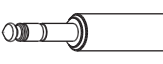
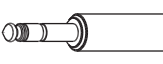
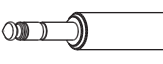
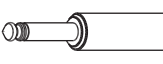
From Output

To Input

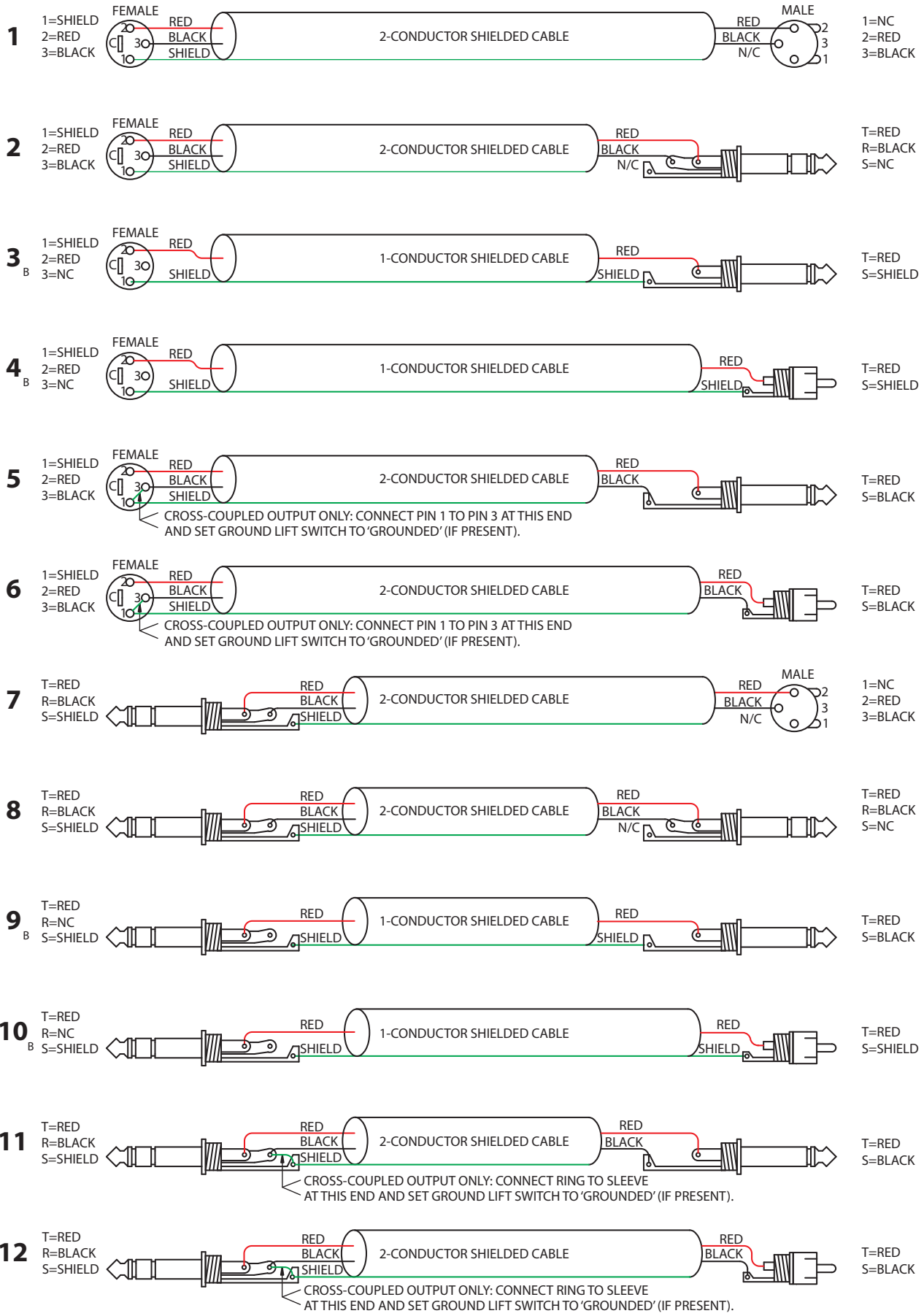

From Output

To Input

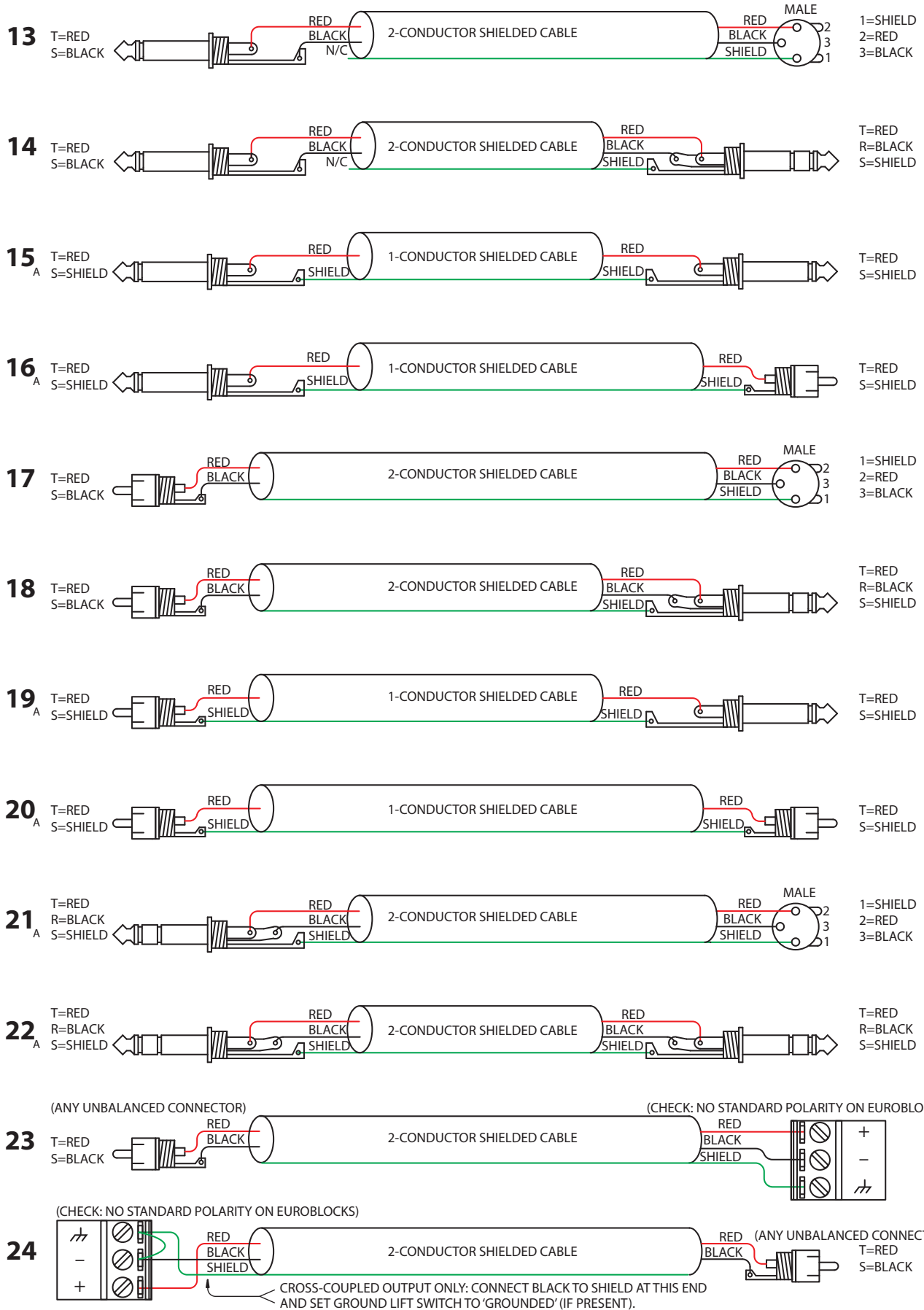

MASTER LEVEL A
MASTER LEVEL B

1 2 3 4 5 6 7 8 9 10 11 12 13 14 15 16

OUTPUT LEVELS

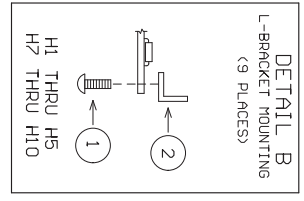
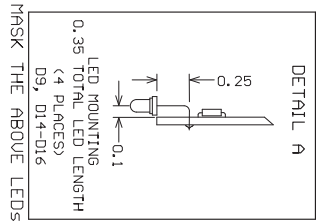
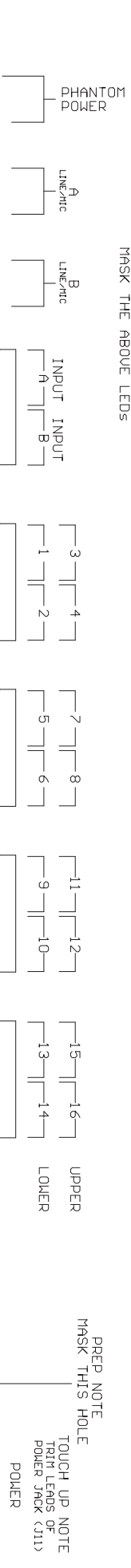
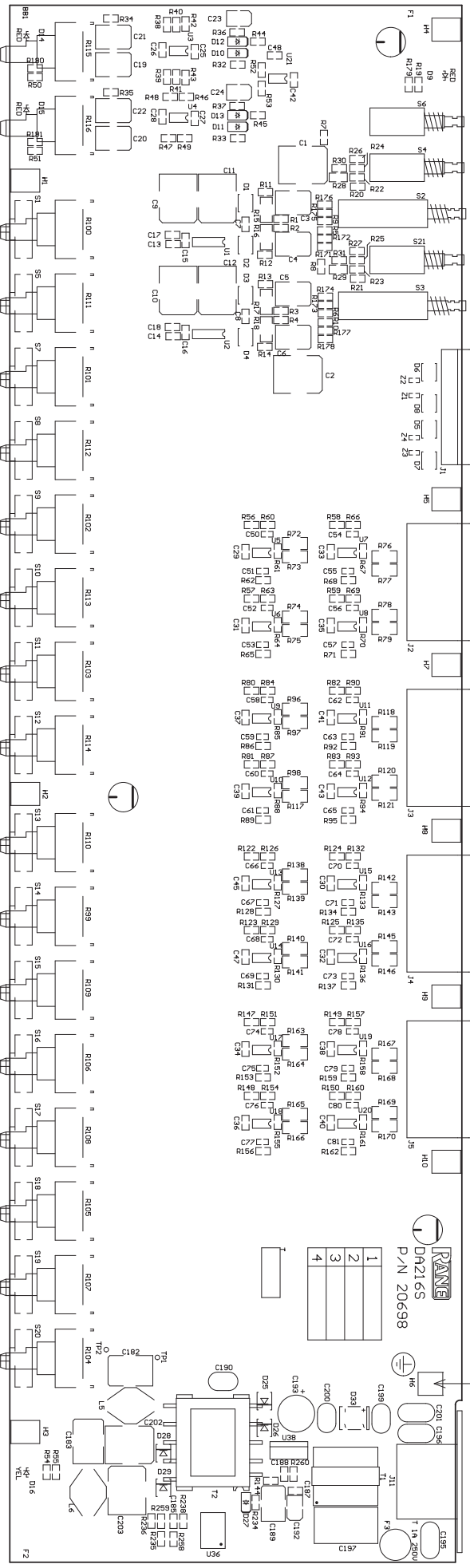

114646 FILM 1 OF 5 COMPONENT SIDE SILKSCREEN DA216S



PREP NOTE
MASK THIS HOLE
TOUCH UP NOTE
TOOTH LEADS OF
POWER JACK (J11)
POWER



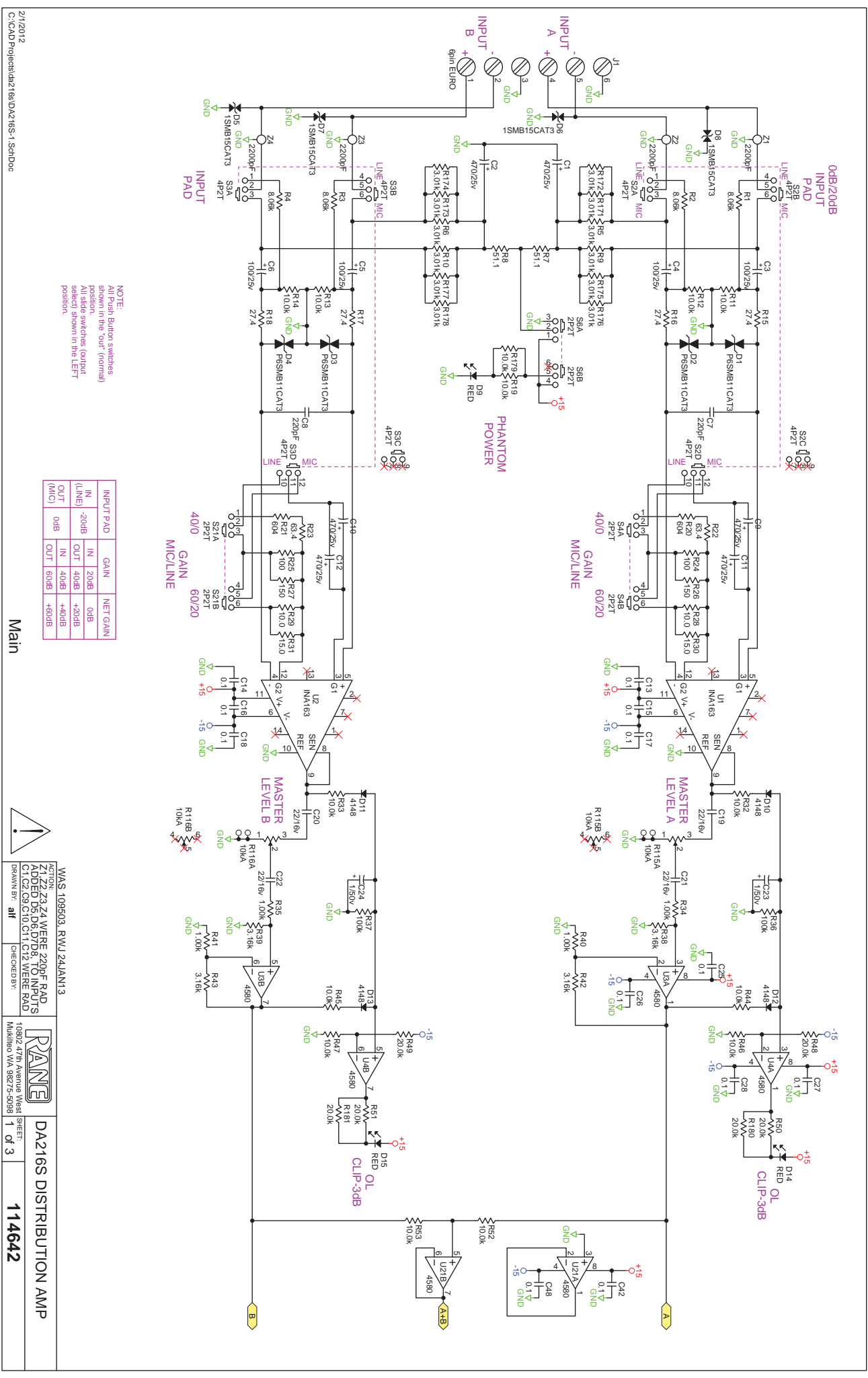

NOTE:
 All Push Buttons switches
 are shown in the "out" (normal)
 position.
 All slide switches (output
 select) shown in the LEFT
 position.

INPUT/PAD	GAIN	NET GAIN
IN	20dB	0dB
(LINE)	OUT	+20dB
OUT	40dB	+40dB
(MIC)	OUT	+80dB

Main



WAS 109503, RWJ 24JAN13

ACTION:
 Z1 Z2 Z3 Z4 WERE 220P F RADS
 ADDED DS, DS, D7 D8, TO INPUTS
 C1, C2, C3, C10, C11, C12 WERE RAD

CHK'D BY: **air** CHECKED BY: _____

RANE DA216S DISTRIBUTION AMP

10902 47th Avenue West
 Mukilteo WA 98275-5098

SHEET 1 of 3

114642

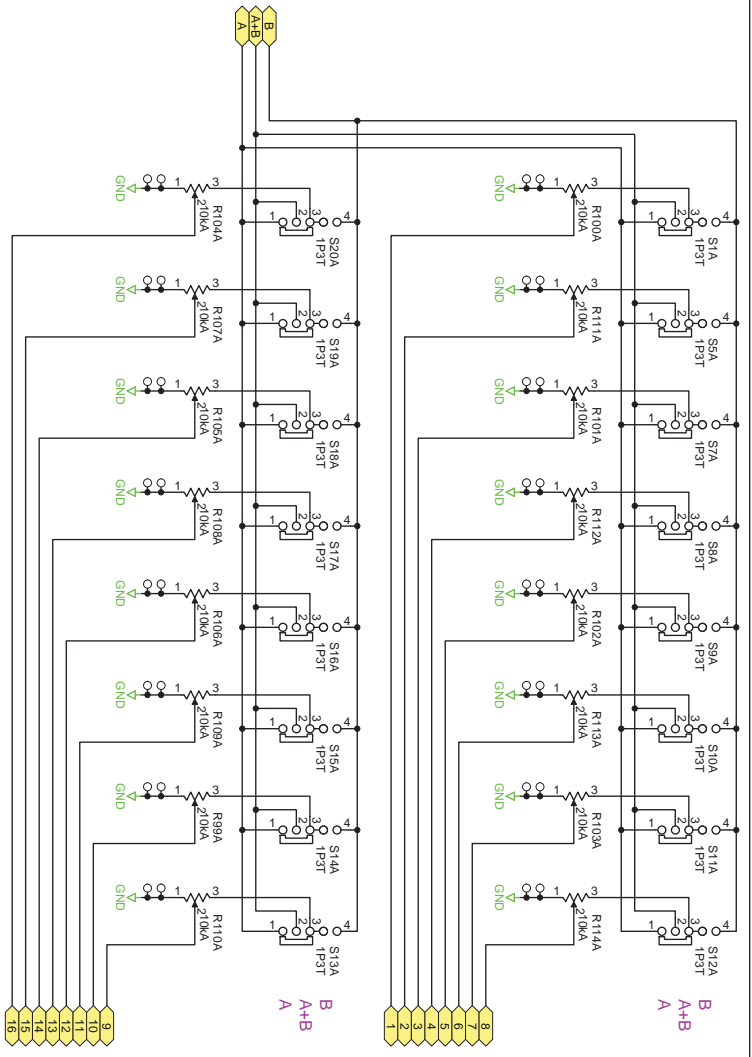
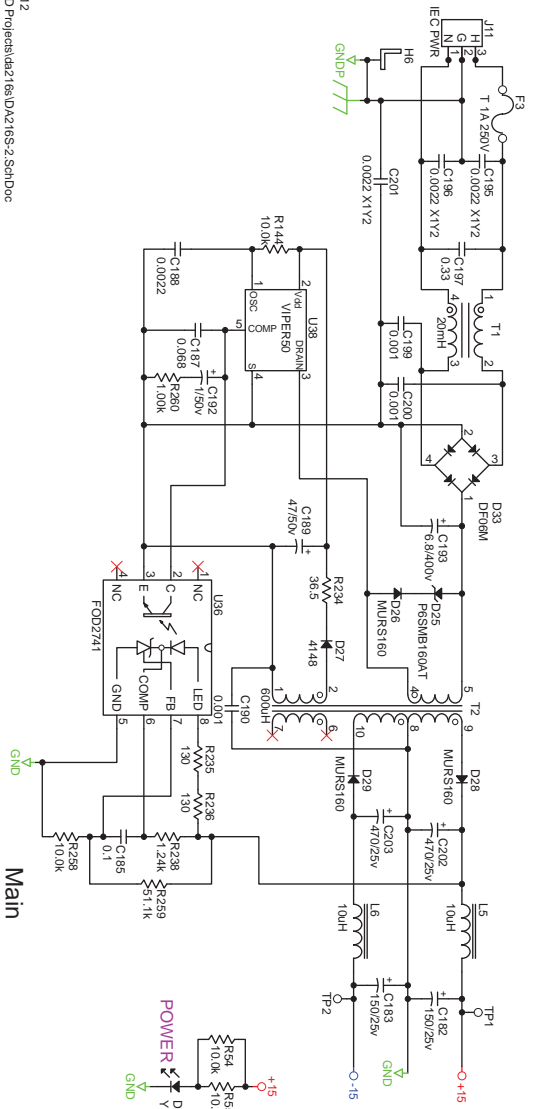
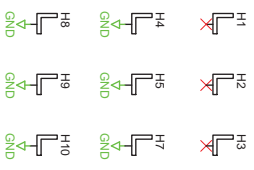
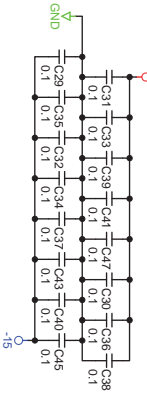

- ~~R100A~~ ~~R100B~~ ~~R100C~~ ~~R100D~~ ~~R100E~~ ~~R100F~~ ~~R100G~~ ~~R100H~~ ~~R100I~~ ~~R100J~~ ~~R100K~~ ~~R100L~~ ~~R100M~~ ~~R100N~~ ~~R100O~~ ~~R100P~~ ~~R100Q~~ ~~R100R~~ ~~R100S~~ ~~R100T~~ ~~R100U~~ ~~R100V~~ ~~R100W~~ ~~R100X~~ ~~R100Y~~ ~~R100Z~~
- ~~R101A~~ ~~R101B~~ ~~R101C~~ ~~R101D~~ ~~R101E~~ ~~R101F~~ ~~R101G~~ ~~R101H~~ ~~R101I~~ ~~R101J~~ ~~R101K~~ ~~R101L~~ ~~R101M~~ ~~R101N~~ ~~R101O~~ ~~R101P~~ ~~R101Q~~ ~~R101R~~ ~~R101S~~ ~~R101T~~ ~~R101U~~ ~~R101V~~ ~~R101W~~ ~~R101X~~ ~~R101Y~~ ~~R101Z~~
- ~~R102A~~ ~~R102B~~ ~~R102C~~ ~~R102D~~ ~~R102E~~ ~~R102F~~ ~~R102G~~ ~~R102H~~ ~~R102I~~ ~~R102J~~ ~~R102K~~ ~~R102L~~ ~~R102M~~ ~~R102N~~ ~~R102O~~ ~~R102P~~ ~~R102Q~~ ~~R102R~~ ~~R102S~~ ~~R102T~~ ~~R102U~~ ~~R102V~~ ~~R102W~~ ~~R102X~~ ~~R102Y~~ ~~R102Z~~
- ~~R103A~~ ~~R103B~~ ~~R103C~~ ~~R103D~~ ~~R103E~~ ~~R103F~~ ~~R103G~~ ~~R103H~~ ~~R103I~~ ~~R103J~~ ~~R103K~~ ~~R103L~~ ~~R103M~~ ~~R103N~~ ~~R103O~~ ~~R103P~~ ~~R103Q~~ ~~R103R~~ ~~R103S~~ ~~R103T~~ ~~R103U~~ ~~R103V~~ ~~R103W~~ ~~R103X~~ ~~R103Y~~ ~~R103Z~~
- ~~R104A~~ ~~R104B~~ ~~R104C~~ ~~R104D~~ ~~R104E~~ ~~R104F~~ ~~R104G~~ ~~R104H~~ ~~R104I~~ ~~R104J~~ ~~R104K~~ ~~R104L~~ ~~R104M~~ ~~R104N~~ ~~R104O~~ ~~R104P~~ ~~R104Q~~ ~~R104R~~ ~~R104S~~ ~~R104T~~ ~~R104U~~ ~~R104V~~ ~~R104W~~ ~~R104X~~ ~~R104Y~~ ~~R104Z~~
- ~~R105A~~ ~~R105B~~ ~~R105C~~ ~~R105D~~ ~~R105E~~ ~~R105F~~ ~~R105G~~ ~~R105H~~ ~~R105I~~ ~~R105J~~ ~~R105K~~ ~~R105L~~ ~~R105M~~ ~~R105N~~ ~~R105O~~ ~~R105P~~ ~~R105Q~~ ~~R105R~~ ~~R105S~~ ~~R105T~~ ~~R105U~~ ~~R105V~~ ~~R105W~~ ~~R105X~~ ~~R105Y~~ ~~R105Z~~
- ~~R106A~~ ~~R106B~~ ~~R106C~~ ~~R106D~~ ~~R106E~~ ~~R106F~~ ~~R106G~~ ~~R106H~~ ~~R106I~~ ~~R106J~~ ~~R106K~~ ~~R106L~~ ~~R106M~~ ~~R106N~~ ~~R106O~~ ~~R106P~~ ~~R106Q~~ ~~R106R~~ ~~R106S~~ ~~R106T~~ ~~R106U~~ ~~R106V~~ ~~R106W~~ ~~R106X~~ ~~R106Y~~ ~~R106Z~~
- ~~R107A~~ ~~R107B~~ ~~R107C~~ ~~R107D~~ ~~R107E~~ ~~R107F~~ ~~R107G~~ ~~R107H~~ ~~R107I~~ ~~R107J~~ ~~R107K~~ ~~R107L~~ ~~R107M~~ ~~R107N~~ ~~R107O~~ ~~R107P~~ ~~R107Q~~ ~~R107R~~ ~~R107S~~ ~~R107T~~ ~~R107U~~ ~~R107V~~ ~~R107W~~ ~~R107X~~ ~~R107Y~~ ~~R107Z~~
- ~~R108A~~ ~~R108B~~ ~~R108C~~ ~~R108D~~ ~~R108E~~ ~~R108F~~ ~~R108G~~ ~~R108H~~ ~~R108I~~ ~~R108J~~ ~~R108K~~ ~~R108L~~ ~~R108M~~ ~~R108N~~ ~~R108O~~ ~~R108P~~ ~~R108Q~~ ~~R108R~~ ~~R108S~~ ~~R108T~~ ~~R108U~~ ~~R108V~~ ~~R108W~~ ~~R108X~~ ~~R108Y~~ ~~R108Z~~
- ~~R109A~~ ~~R109B~~ ~~R109C~~ ~~R109D~~ ~~R109E~~ ~~R109F~~ ~~R109G~~ ~~R109H~~ ~~R109I~~ ~~R109J~~ ~~R109K~~ ~~R109L~~ ~~R109M~~ ~~R109N~~ ~~R109O~~ ~~R109P~~ ~~R109Q~~ ~~R109R~~ ~~R109S~~ ~~R109T~~ ~~R109U~~ ~~R109V~~ ~~R109W~~ ~~R109X~~ ~~R109Y~~ ~~R109Z~~
- ~~R110A~~ ~~R110B~~ ~~R110C~~ ~~R110D~~ ~~R110E~~ ~~R110F~~ ~~R110G~~ ~~R110H~~ ~~R110I~~ ~~R110J~~ ~~R110K~~ ~~R110L~~ ~~R110M~~ ~~R110N~~ ~~R110O~~ ~~R110P~~ ~~R110Q~~ ~~R110R~~ ~~R110S~~ ~~R110T~~ ~~R110U~~ ~~R110V~~ ~~R110W~~ ~~R110X~~ ~~R110Y~~ ~~R110Z~~
- ~~R111A~~ ~~R111B~~ ~~R111C~~ ~~R111D~~ ~~R111E~~ ~~R111F~~ ~~R111G~~ ~~R111H~~ ~~R111I~~ ~~R111J~~ ~~R111K~~ ~~R111L~~ ~~R111M~~ ~~R111N~~ ~~R111O~~ ~~R111P~~ ~~R111Q~~ ~~R111R~~ ~~R111S~~ ~~R111T~~ ~~R111U~~ ~~R111V~~ ~~R111W~~ ~~R111X~~ ~~R111Y~~ ~~R111Z~~
- ~~R112A~~ ~~R112B~~ ~~R112C~~ ~~R112D~~ ~~R112E~~ ~~R112F~~ ~~R112G~~ ~~R112H~~ ~~R112I~~ ~~R112J~~ ~~R112K~~ ~~R112L~~ ~~R112M~~ ~~R112N~~ ~~R112O~~ ~~R112P~~ ~~R112Q~~ ~~R112R~~ ~~R112S~~ ~~R112T~~ ~~R112U~~ ~~R112V~~ ~~R112W~~ ~~R112X~~ ~~R112Y~~ ~~R112Z~~
- ~~R113A~~ ~~R113B~~ ~~R113C~~ ~~R113D~~ ~~R113E~~ ~~R113F~~ ~~R113G~~ ~~R113H~~ ~~R113I~~ ~~R113J~~ ~~R113K~~ ~~R113L~~ ~~R113M~~ ~~R113N~~ ~~R113O~~ ~~R113P~~ ~~R113Q~~ ~~R113R~~ ~~R113S~~ ~~R113T~~ ~~R113U~~ ~~R113V~~ ~~R113W~~ ~~R113X~~ ~~R113Y~~ ~~R113Z~~
- ~~R114A~~ ~~R114B~~ ~~R114C~~ ~~R114D~~ ~~R114E~~ ~~R114F~~ ~~R114G~~ ~~R114H~~ ~~R114I~~ ~~R114J~~ ~~R114K~~ ~~R114L~~ ~~R114M~~ ~~R114N~~ ~~R114O~~ ~~R114P~~ ~~R114Q~~ ~~R114R~~ ~~R114S~~ ~~R114T~~ ~~R114U~~ ~~R114V~~ ~~R114W~~ ~~R114X~~ ~~R114Y~~ ~~R114Z~~

Main



WAS 109503, RWJ 24JUN12	ACTION: C202, C203 WERE 470/16V RAD C182, C183 WERE 120V/16V RAD L5, L6 WERE RAD	DRWNR: air	CHECKED BY:	RAVE 10902 47th Avenue West Murrieta WA 98275-5098	SHEET 2 of 3	DA216S SELECTION MATRIX 114642
-------------------------	---	-------------------	-------------	---	-----------------	--

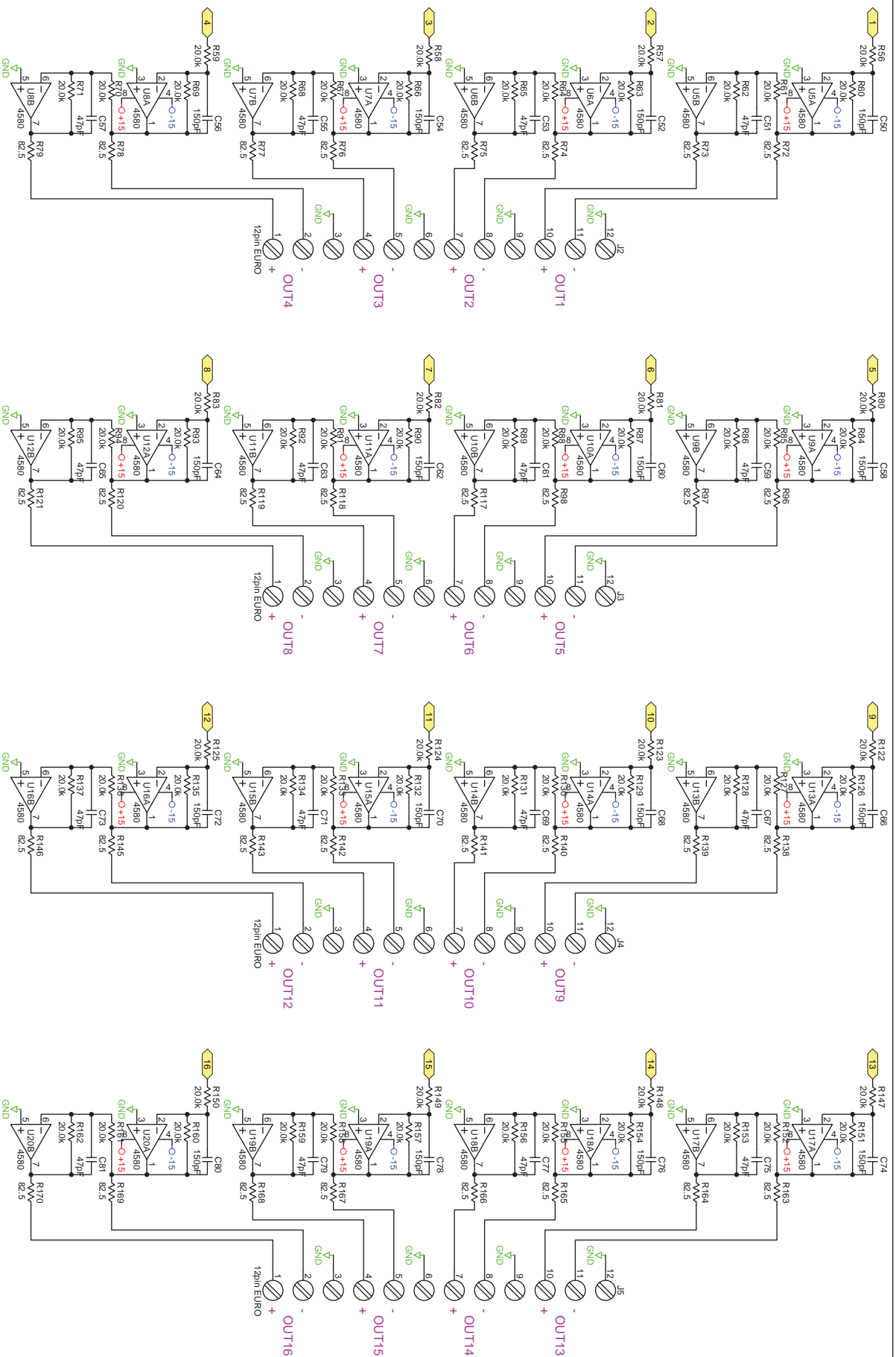

Main



ACTION: NO CHANGES ON THIS PAGE			DA216S OUTPUT DRIVERS
DRAWN BY: air	CHECKED BY:		
SHEET: 3 of 3		114642	



FACTORY AUTHORIZED SERVICE

Your unit may be serviced by the Rane Factory or any Authorized Rane Service Center. To find a Service Center near you, please call the Rane factory, or check the Rane website. Please do not return your unit to Rane without prior authorization.

Rane Corporation

To obtain service or a Return Authorization, please phone 425-355-6000

or Fax 425-347-7757

The current list of U.S. Rane Authorized Service Centers is found on our website: www.rane.com/service.html

LIMITED DOMESTIC WARRANTY

RANE CORPORATION WARRANTS ALL RANE PRODUCTS (EXCEPT THOSE ITEMS CLASSIFIED AS *WEAR PARTS*, AND LISTED ON THE MANUAL-1 PAGE OF EACH OPERATORS MANUAL) PURCHASED IN THE USA AGAINST DEFECTS IN MATERIAL OR WORKMANSHIP FOR A PERIOD OF TWO (2) YEARS. *WEAR PARTS* ARE LIMITED TO A PERIOD OF NINETY (90) DAYS FROM THE INITIAL DATE OF RETAIL PURCHASE FROM AN AUTHORIZED RANE DEALER—*WEAR PARTS* REQUIRE PROOF OF PURCHASE DATE. This limited warranty extends to all purchasers or owners of the product during the warranty period beginning with the original retail purchase. Rane Corporation does not, however, warrant its products against any and all defects: 1) arising out of material or workmanship not provided or furnished by Rane, or 2) resulting from abnormal use of the product or use in violation of instructions, or 3) in products repaired or serviced by other than authorized Rane repair facilities, or 4) in products with removed or defaced serial numbers, or 5) in components or parts or products expressly warranted by another manufacturer. Rane agrees to supply all parts and labor to repair or replace defects covered by this limited warranty with parts or products of original or improved design, at its option in each respect, if the defective product is shipped prior to the end of the warranty period to any Rane authorized warranty repair facility in the U.S. or to the Rane factory in the original packaging or a replacement supplied by Rane, with all transportation costs and full insurance paid each way by the purchaser or owner.

LIMITED WARRANTY OUTSIDE THE U.S.A.

RANE PRODUCTS ARE WARRANTED ONLY IN THE COUNTRY WHERE PURCHASED, THROUGH THE AUTHORIZED RANE DISTRIBUTOR IN THAT COUNTRY, AGAINST DEFECTS IN MATERIAL OR WORKMANSHIP, THE SPECIFIC PERIOD OF THIS LIMITED WARRANTY SHALL BE THAT WHICH IS DESCRIBED TO THE ORIGINAL RETAIL PURCHASER BY THE AUTHORIZED RANE DEALER OR DISTRIBUTOR AT THE TIME OF PURCHASE. Rane Corporation does not, however, warrant its products against any and all defects: 1) arising out of materials or workmanship not provided or furnished by Rane, or 2) resulting from abnormal use of the product or use in violation of instructions, or 3) in products repaired or serviced by other than authorized Rane repair facilities, or 4) in products with removed or defaced serial numbers, or 5) in components or parts or products expressly warranted by another manufacturer. Rane agrees, through the applicable authorized distributor, to repair or replace defects covered by this limited warranty with parts or products of original or improved design, at its option in each respect, if the defective product is shipped prior to the end of the warranty period to the designated authorized Rane warranty repair facility in the country where purchased, or to the Rane factory in the U.S., in the original packaging or a replacement supplied by Rane, with all transportation costs and full insurance paid each way by the purchaser or owner.

ALL REMEDIES AND THE MEASURE OF DAMAGES ARE LIMITED TO THE ABOVE SERVICES, IT IS POSSIBLE THAT ECONOMIC LOSS OR INJURY TO PERSON OR PROPERTY MAY RESULT FROM THE FAILURE OF THE PRODUCT; HOWEVER, EVEN IF RANE HAS BEEN ADVISED OF THIS POSSIBILITY, THIS LIMITED WARRANTY DOES NOT COVER ANY SUCH CONSEQUENTIAL OR INCIDENTAL DAMAGES. SOME STATES OR COUNTRIES DO NOT ALLOW THE LIMITATIONS OR EXCLUSION OF INCIDENTAL OR CONSEQUENTIAL DAMAGES, SO THE ABOVE LIMITATION MAY NOT APPLY TO YOU.

ANY AND ALL WARRANTIES, EXPRESS OR IMPLIED, ARISING BY LAW, COURSE OF DEALING, COURSE OF PERFORMANCE, USAGE OF TRADE, OR OTHERWISE, INCLUDING BUT NOT LIMITED TO IMPLIED WARRANTIES OF MERCHANTABILITY AND FITNESS FOR A PARTICULAR PURPOSE, ARE LIMITED TO A PERIOD OF TWO (2) YEARS FROM EITHER THE DATE OF ORIGINAL RETAIL PURCHASE OR, IN THE EVENT NO PROOF OF PURCHASE DATE IS AVAILABLE, THE DATE OF MANUFACTURE, SOME STATES OR COUNTRIES DO NOT ALLOW LIMITATIONS ON HOW LONG AN IMPLIED WARRANTY LASTS, SO THE ABOVE LIMITATIONS MAY NOT APPLY TO YOU. THIS LIMITED WARRANTY GIVES YOU SPECIFIC LEGAL RIGHTS, AND YOU MAY ALSO HAVE OTHER RIGHTS WHICH VARY FROM STATE TO STATE, COUNTRY TO COUNTRY.

WARRANTY PROCEDURE - Only Valid in the USA

NOTICE! You must complete and return the warranty card or register your product online to extend the Warranty from 2 years to 3 years!

TO VALIDATE YOUR EXTENDED WARRANTY: Use the postcard that came in the box with your unit, or go to www.rane.com and click on **New Product Registration**. Fill out the warranty completely, being sure to **include the model and serial number** of the unit since this is how warranties are tracked. If your Rane product was purchased in the USA, mail the completed card or register online with to Rane Corporation within 10 days from the date of purchase. **If you purchased the product outside the USA you must file your warranty registration with the Rane Distributor in that country.** It is advised that you keep your bill of sale as proof of purchase, should any difficulties arise concerning the registration of the warranty card. **NOTICE: IT IS NOT NECESSARY TO REGISTER IN ORDER TO RECEIVE RANE CORPORATION'S STANDARD TWO YEAR LIMITED WARRANTY.**

WARRANTY REGISTRATION is made and tracked by **model and serial numbers only**, not by the purchaser's or owner's name. Therefore any warranty correspondence or inquires **must** include the model and serial number of the product in question. Be sure to fill in the model and serial number in the space provided below and keep this in a safe place for future reference.

WARRANTY SERVICE MUST BE PERFORMED ONLY BY AN AUTHORIZED RANE SERVICE FACILITY LOCATED IN THE COUNTRY WHERE THE UNIT WAS PURCHASED, OR (if product was purchased in the USA) AT THE RANE FACTORY IN THE USA. If the product is being sent to Rane for repair, please call the factory for a Return Authorization number. We recommend advance notice be given to the repair facility to avoid possible needless shipment in case the problem can be solved over the phone. **UNAUTHORIZED SERVICE PERFORMED ON ANY RANE PRODUCT WILL VOID ITS EXISTING FACTORY WARRANTY.**

FACTORY SERVICE

If you wish your Rane product to be serviced at the factory, **it must be shipped fully insured, in the original packing box or equivalent.** This warranty will **not** cover repairs on products damaged through improper packaging. If possible, avoid sending products through the mail. Be sure to include in the package:

1. Complete return street shipping address (P.O. Box numbers are **not** acceptable).
2. A detailed description of any problems experienced, including the make and model numbers of any other system equipment.
3. Remote power supply, if applicable.

Repaired products purchased in the U.S. will be returned prepaid freight via the same method they were sent to Rane. Products purchased in the USA, but sent to the factory from outside the USA **must** include return freight funds, and the sender is fully responsible for all customs procedures, duties, tariffs and deposits.

In order to qualify for Rane's one year extended warranty (for a total of 3 years parts and labor), the warranty must be completely filled out and sent to us immediately. Valid in USA only.

We recommend you write your serial number here in your owners manual and on your sales receipt for your records.

SERIAL NUMBER: _____ PURCHASE DATE: _____

Declaration of Conformity

Application of Council Directive(s):

2001/95/EC
2012/19/EU
2004/108/EC
2006/95/EC
2011/65/EU

Standard(s) to which conformity is declared:

EN60065: 2002/A1:2006/A11:2008/A2:2010/A12:2011
EN55103-1:2009
EN55103-2:2009
EN50581:2012
ENVIRONMENT E2
CE MARK FIRST AFFIXED IN 2007
SERIAL NUMBERS 900000 - 999999

Manufacturer:

Rane Corporation
10802 47th Avenue West
Mukilteo WA 98275-5000 USA

This equipment has been tested and found to be in compliance with all applicable standards and regulations applying to the EU's Low Voltage (LV) directive 2006/95/EC, and Electromagnetic Compatibility (EMC) directive 2004/108/EC. In order for the customer to maintain compliance with this regulation, high quality shielded cable must be used for interconnection to other equipment. Modification of the equipment, other than that expressly outlined by the manufacturer, is not allowed under this directive. The user of this equipment shall accept full responsibility for compliance with the LV directive and EMC directive in the event that the equipment is modified without written consent of the manufacturer. This declaration of conformity is issued under the sole responsibility of Rane Corporation.

Type of Equipment: Professional Audio Signal Processing

Brand: Rane

Model: DA216S

Immunity Results:

THD+N re: 4 dBu, 400 Hz, BW=20-20kHz

Test Description

Results

Conditions

RF Electromagnetic Fields Immunity

80 MHz - 1000 MHz, 1 kHz AM, 80% depth, 3V/m

< -35 dB

80 MHz - 200 MHz

< -40 dB

200 MHz - 1000 MHz

Conducted RF Disturbances Immunity

150 kHz - 80 MHz, 1 kHz AM, 80% depth, 3V rms

< -87 dB

Power Lines

< -48 dB

Signal Lines

Magnetic Fields Immunity

50 Hz - 10 kHz, 4.0 - 0.4 A/m

< -90 dB

I, the undersigned, hereby declare that the equipment specified above conforms to the Directive(s) and Standard(s) shown above.



(Signature)

Roy G. Gill

(Full Name)

Compliance Engineer

(Position)

December 14, 2010

(Date)

Mukilteo WA USA

(Place)

DA216S

DISTRIBUTION AMPLIFIER

