



Digitally Steerable Line Array Loudspeaker Systems

# IC Live

## ICL-R & IC215S-R

### USERS MANUAL



Version 1.10.4



## IMPORTANT SAFETY INSTRUCTIONS

1. Read these instructions.
2. Keep these instructions.
3. Heed all warnings.
4. Follow all instructions
5. Do not use this apparatus near water. The apparatus shall not be exposed to dripping or splashing and no objects filled with liquids, such as vases, shall be placed on it.
6. Clean only with dry cloth.
7. Do not block any ventilation openings. Install in accordance with the manufacturer's instructions.
8. Do not install near any heat sources such as radiators, heat registers, stoves, or other apparatus (including amplifiers) that produce heat.
9. Do not defeat the safety purpose of the polarized or grounding-type plug. A polarized plug has two blades with one wider than the other. A grounding type plug has two blades and a third grounding prong. The wide blade or the third prong is provided for your safety. If the provided plug does not fit into your outlet, consult an electrician for replacement of the obsolete outlet.
10. Protect the power cord from being walked on or pinched particularly at plugs, convenience receptacles, and the point where they exit from the apparatus.
11. Make sure the power cord remains readily accessible at all times.
12. The AC Power Cord is the AC Mains disconnect.
13. Only use attachments/accessories specified by the manufacturer.
14. Unplug this apparatus during lightning storms or when unused for long periods of time or during transportation..
15. Refer all servicing to qualified service personnel. Servicing is required when the apparatus has been damaged in any way, such as power-supply cord or plug is damaged, liquid has been spilled or objects have fallen into the apparatus, the apparatus has been exposed to rain or moisture, does not operate normally, or has been dropped.

**“WARNING - TO REDUCE THE RISK OF FIRE OR ELECTRIC SHOCK, DO NOT EXPOSE THIS APPARATUS TO RAIN OR MOISTURE”**

**“CAUTION: THESE SERVICING INSTRUCTIONS ARE FOR USE BY QUALIFIED SERVICE PERSONNEL ONLY. TO REDUCE THE RISK OF ELECTRIC SHOCK DO NOT PERFORM ANY SERVICING OTHER THAN THAT CONTAINED IN THE OPERATING INSTRUCTIONS UNLESS YOU ARE QUALIFIED TO DO SO”.**

Explanation of Graphical Symbols



The lightning flash with arrowhead symbol, within an equilateral triangle, is intended to alert the user to the presence of uninsulated "Dangerous Voltage" within the product's enclosure that may be of sufficient magnitude to constitute a risk of electric shock to humans.



The exclamation point, within an equilateral triangle, indicates the presence of important operating and maintenance (servicing) instructions in the literature accompanying the product.

Erklärung der graphischen Symbole



Der Blitz mit nach untenzielendem Pfeil in einem gleichseitigen Dreieck weist den Benutzer auf das Vorhandensein einer unisolierten, "gefährlichen Spannung" im Gehäuse hin, die stark genug sein kann, einer Person einen gefährlichen elektrischen Schlag zu versetzen.



Das Ausrufezeichen in einem gleichseitigen Dreieck weist den Benutzer auf wichtige Betriebs- und Wartungsvorschriften in den beiliegenden Unterlagen des Gerätes hin.

**CAUTION**

**RISK OF ELECTRONIC SHOCK:  
OPEN ONLY IF QUALIFIED AS  
SERVICE PERSONNEL**

**VORSICHT**

**GEFAHR EINES ELEKTRISCHEN SCHLAGES:  
NUR VON QUALIFIZIEREM WARTUNGSPERSONAL  
ZU ÖFFNEN**

To reiterate the above warnings: servicing instructions are for use by qualified personnel only. To avoid electric shock, do not perform any servicing other than that contained in the Operation Instructions unless you are qualified to do so. Refer all servicing to qualified personnel.

Eindringliche Warnung: Wartungsvorschriften dienen nur der Benutzung durch qualifiziertes Personal. Zur Vermeidung eines elektrischen Schlages keine anderen als die in den Betriebsvorschriften beschriebenen Wartungsarbeiten ausführen, es sei denn Sie sind dafür qualifiziert. Wartungsarbeiten auszuführen.

### IMPORTANT

**Your Iconyx Steerable Column Loudspeaker contains no user-serviceable parts and all service should be referred to qualified service personnel.**

## TABLE OF CONTENTS

	Page
<b>Section 1: Basic Operating Instructions</b>	
<b>Introduction, Technical Support, General Information</b>	4
<b>Setup &amp; Assembly Instructions</b>	5
Common Setups	5
Assembly	6
Master / Slave Settings	7
<b>Wiring Diagrams</b>	8
Basic Setups - No PC Control	8
With PC Control	9
<b>Array Input / Power Connections</b>	10
<b>Operation (with no PC)</b>	11
Presets	11
<b>Operation (Computer Controlled)</b>	14
Assigning Digital & Analog Inputs	16
DSP Control	17
Panel Controls	19
SysTune Interface	19
<b>Section 2: Additional User Information</b>	
<b>Initial Setup</b>	22
Computer Requirements	22
Installing RHAON	22
Assigning a Static IP Address	23
Network Manager	24
<b>Virtual Systems</b>	25
Linking Software With Networked Loudspeakers	26
CobraNet Signal Routing	28
<b>Beam Steering</b>	30
<b>All Loudspeakers / Group Controls</b>	39
<b>Copy Settings / Copy Presets</b>	41
<b>Reset</b>	41
<b>Supervise Mode</b>	42
Event Logging & Notification	44
<b>General Preferences</b>	45
<b>Password Protection</b>	46
<b>Keeping Your RHAON Program Up-To-Date</b>	48
Software Updates	49
Updating Microcontroller Firmware	50
Updating DSP Firmware	52
<b>Servicing / Trouble Shooting Hints</b>	54
Network Manager	57
<b>Dimensions &amp; Technical Specifications</b>	
IC L-R Array	65
IC215S-R Subwoofer	67
<b>Index</b>	69

## INTRODUCTION

Congratulations on your purchase of a Renkus-Heinz RHAON empowered, digitally steered IC Live column loudspeaker. We hope you enjoy it.

Your IC Live digitally steerable column loudspeaker was carefully tested and inspected before leaving our factory and should have arrived in perfect condition. Please carefully inspect the shipping carton(s) and loudspeaker(s) for any noticeable damage, and if any damage is found, immediately notify the shipping company. Only you, the consignee, may institute a claim with the carrier for any damage incurred during shipping. Be sure to save the carton(s) and all packing material for the carrier's inspection. It is also a good idea to save the carton and packing material even though the loudspeaker arrived in good condition. If you should ever need to ship the loudspeaker, it should be shipped in its original factory packaging.

## TECHNICAL SUPPORT

If you have any questions about RHAON-Empowered Loudspeakers or encounter a problem designing, installing, setting up or operating a RHAON system, please call our technical support staff at 949-588-9997 and ask the operator for technical support on RHAON. Call Monday through Friday from 8:00 AM to 5:00 PM Pacific Time.

The latest information on RHAON Technical Support is always available online at <http://www.renkus-heinz.com/support/software-support/raon/e-mail.html>. You will also find a support request form at <http://www.renkus-heinz.com/support/request-info/tech-info/>

## General Information

IC Live line array systems were developed specifically for live event productions. They are ideally suited for a wide range of event types and sizes, are easy to transport and setup, and deliver superior sound in a broad spectrum of environments.

Thanks to digitally controlled beam steering they deliver narrow vertical beams of sonic energy that can be directed onto the audience instead of reverberating off the walls and ceilings. Horizontal coverage is a consistent 150° eliminating the need for left and right setups in most venues. Preset configurations for different size and shape venues reduce setup time to a minimum.

This guide was written to assist you in setting up and operating IC Live systems.

## System Types - Master & Slave and All Master

IC Live systems can be operated as either a Master & Slave system or as an all Master system in Master and Slave systems one module is designated as the Master and all other modules are Slaves controlled by the Master module. All signal cables terminate in the Master module. In an All Master system, all modules act as master modules and there are no slave modules. All signal cables must be brought individually into each module.

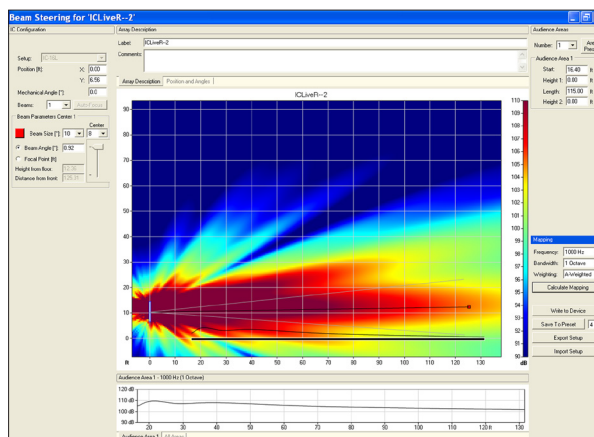

### Common Setups



ICL-R digitally steered line arrays and IC215S-R subwoofers were designed to work together, both acoustically and mechanically with the subwoofer supplying both the extra bass impact needed by most musical productions and a solid mounting base for the tall slender columns. Together, the two building blocks form 6 useful configurations.

The unique interlocking hardware system with quick release pins joins the line array and the subwoofer together into a rigid assembly, allowing the subwoofers to be used as mounting bases for the columns. When used as a mounting base, the subwoofers also raise the line array above the floor.



ICL-R arrays perform best when their acoustic center, the point of origination for the narrow acoustic beam, is several feet above the ear level of the audience. If it's placed lower, too much of the sonic beam is absorbed by the first row of the audience and never reaches those in the rear. If it's placed much higher, the narrow vertical beam tends to "light up" the center of the audience and drop off in both the front and rear.

This puts the ideal height for the bottom of an ICL-R array at roughly four feet above the floor for a seated audience.

An IC215S-R standing on end is 4' tall making the combination of an ICL-R array mounted on top of a standing IC215S-R subwoofer an ideal arrangement for many setups.

An IC215S-R subwoofer laid on its side and a single ICL-R array work well when space is available for them on the stage. Mounting two stacked arrays on a single subwoofer is not recommended, as the assembly is unstable.



Dual subwoofer assemblies combined with either a single ICL-R array or with two stacked ICL-R arrays are two other popular configurations. The dual subwoofers provide the desired mounting height for the array(s) and enough bass for even the most demanding musical events.

Stacked ICL-R arrays provide tighter beam control than a single ICL-R and a much higher output level. They are especially desirable in reverberant rooms where tight control of the beam is needed to deliver clear speech over a considerable distance.

When only speech is involved and the bass support provided by the subwoofers is not needed, single or stacked ICL-R arrays are an ideal solution. They can be attached to the truss work with Chesebrough clamps or by removing the array's rear pole/handle and using the pole clamps to secure the array to the truss.

ICL-R arrays are also equipped with AeroQuip Fly-Track, so they can also be easily flown from the truss with industry standard AeroQuip hardware.



## Assembly

IC Live is a building block system designed for easy transportation, setup and tear down. It provides for 6 system configurations from two basic modules, the ICL-R array module and the IC215S-R subwoofer.

Setup couldn't be easier. To create a stacked array from two ICL-R modules:

**1.** Stand the two column arrays side by side and remove the two joining bars and their short quick release pins from the modules.

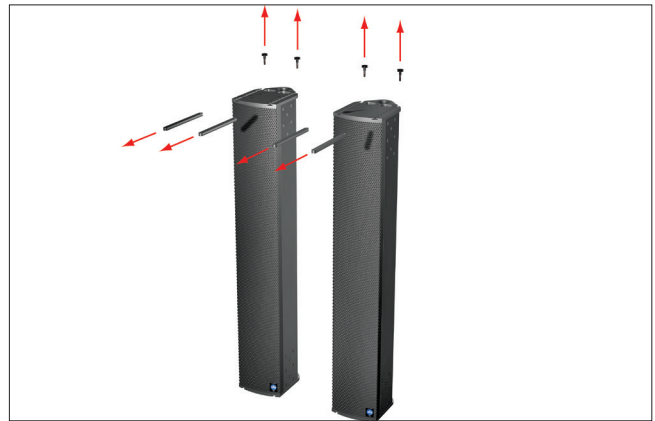

**2.** Place one of the modules on top of the other one. Note that the top module should be turned upside down so the horn sections of the two modules are together.

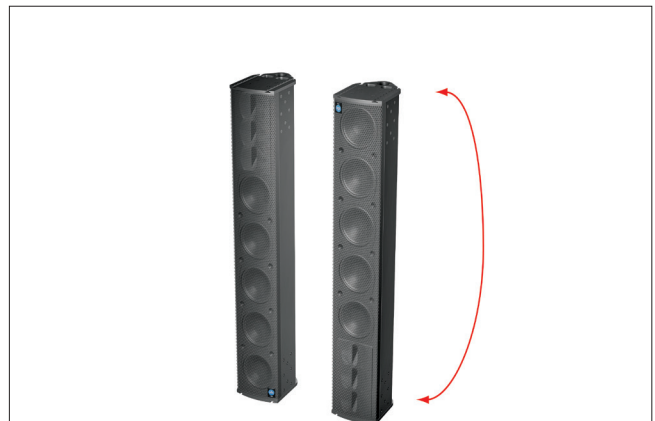

**3.** Align the two modules and then remove the quick release pin from the upper module's rear cylinder to allow its inner sleeve to drop down into the lower module's rear cylinder.



**4.** Then re-insert the quick release pin into the upper module's cylinder to lock the inner sleeve in place.



Assembly (continued)

5. Slide the two joining bars into the channels as shown.

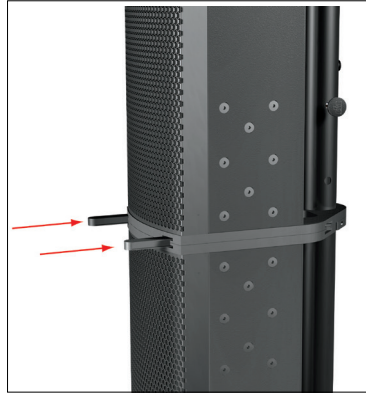

6. Lock the joining bars into place with the short quick release pins to complete the physical assembly.



Note: If you are assembling a “triple stack”, follow the same procedure to place the third module on top of the second module with one exception. The woofer sections of the second and third modules should be joined together. If in doubt, refer to page 65 for proper module orientation.

The procedure for mounting an ICL-R array onto an IC215S-R subwoofer is the same. The only difference is the array’s rear cylinder sleeve drops into the socket on either the top or the end of the subwoofer. When mounting a stack (two ICL-R arrays) on top of one or two subwoofers, it is best to first mount the lower line array module onto the subwoofer and then attach the top line array. It’s easier and safer. **Do not attempt to mount a stacked ICL-R array onto a subwoofer standing vertically. The resulting assembly is unstable.**

**Note: If you should be using an IC212S-R dual 12” subwoofer, you will need a pair of MET001 joining bars to replace the ones supplied with the ICL-R array module. The ones supplied with the ICL-R will not work with the IC212S-R**

Master / Slave Settings

The next step in Master & Slave systems is to electrically link the modules together and verify the Master/Slave assignment is correct. The bottom module always functions as the Master and the upper modules as Slaves. The module directly above the Master module is identified as Slave 1 and the module above it as Slave 2. All incoming signal and AC power connections should be made to the Master.

Plug one end of the short CAT5 linking cable into the lower interconnect socket on the Master (lower) module and the other end into the upper socket on the upper module. Then plug one end of the short AC power cable into the looping power socket on the lower module and the other end into the power socket on the upper module. Follow the same procedure to connect a third module, if one is provided.

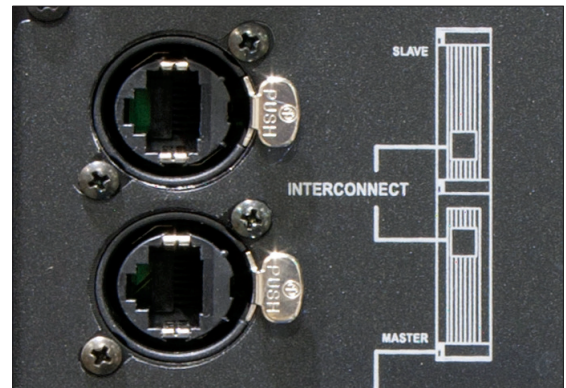

The next step is to set the two dip switches that identify each module. Set the Master switches first; The graphic directly below the two dip switches shows the proper setting for a Master module (both switches in the down position). Then set the Slave module(s) dip switches following the settings shown in the graphic. Note that the Slave #3 switch is for future use.

On All Master systems, set each module’s dip switches to the Master position.

Note: If you connected power to the array before setting the dip switches, you will need to turn it off or disconnect it at the source and then reconnect it before the dip switch settings will take effect. When properly set in Master & Slave systems the digital readouts will both read 20 in a dual array and 30 in a three module array.

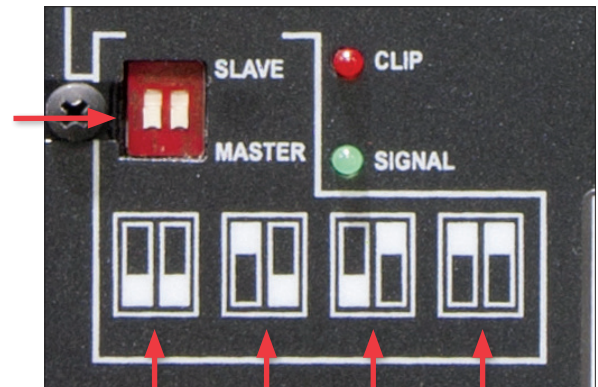

Master setting    Slave #1 setting    Slave #2 setting    Slave #3 setting

### Wiring Diagrams For Basic Setups

IC Live arrays were developed for a wide range of different size and types of venues, including even large multi-array events. They include RHAON, the Renkus-Heinz Audio Operations Network, which provides operational control and supervision of multiple arrays from a remotely located computer and multi-channel digital audio distribution.

When remote computer supervision and control is not needed, IC Live arrays can be treated just like any other self-powered loudspeaker. Simply connect an analog audio signal, plug in the power, make sure the correct Preset is selected and adjust the level. See drawings below.

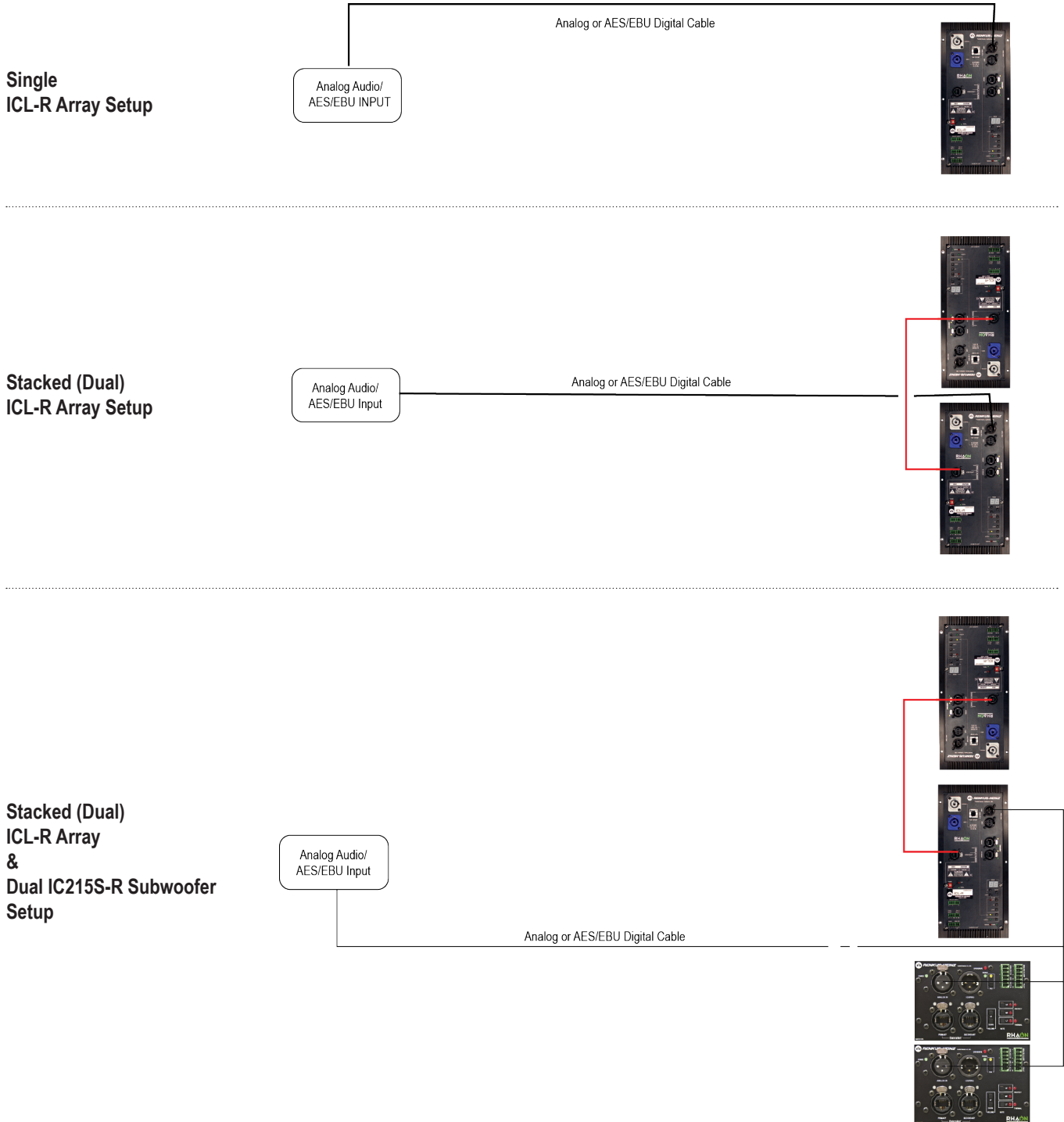

### System Wiring With PC Control

Notice that no Ethernet switch is needed in single array setups. Instead, only a simple Ethernet Crossover cable is required. An Ethernet switch is needed only when there are two or more devices, such as an array and a subwoofer. A stacked array is treated as a single device since it performs as one even though it has two modules.

Satisfactory 100 BaseT Ethernet switches of many sizes (output ports) are available from a number of sources. Unmanaged switches are adequate for most applications. Managed switches are not required.

Systems using CobraNet digital audio distribution require either a suitable analog to CobraNet converter or a mixing console with a CobraNet output. Suitable analog to CobraNet converters are available from a number of sources, such as Bi-Amp, Peavey and others. The converter's output would plug into one of the Ethernet switch ports.

#### Single ICL-R Array Setup with Computer Control

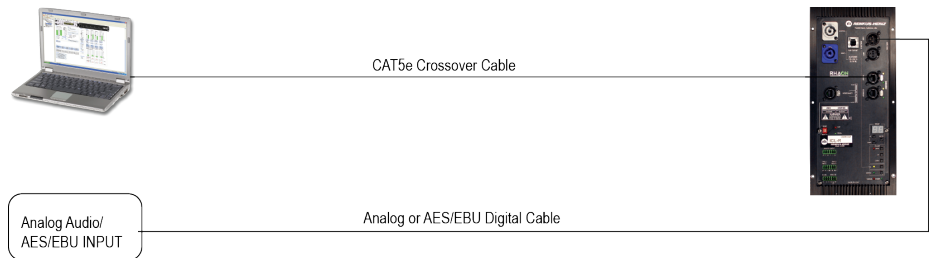

#### Stacked (Dual) ICL-R Array Setup With Computer Control

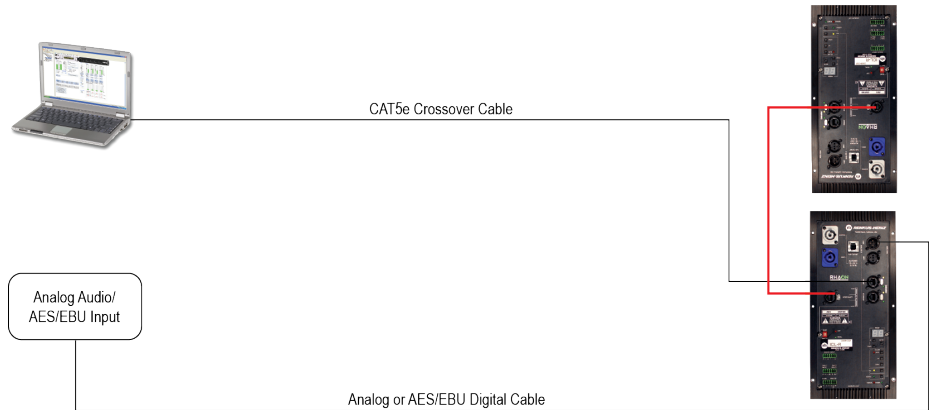

#### Stacked (Dual) ICL-R Array and Dual IC215S-R Subwoofer Setup with Computer Control

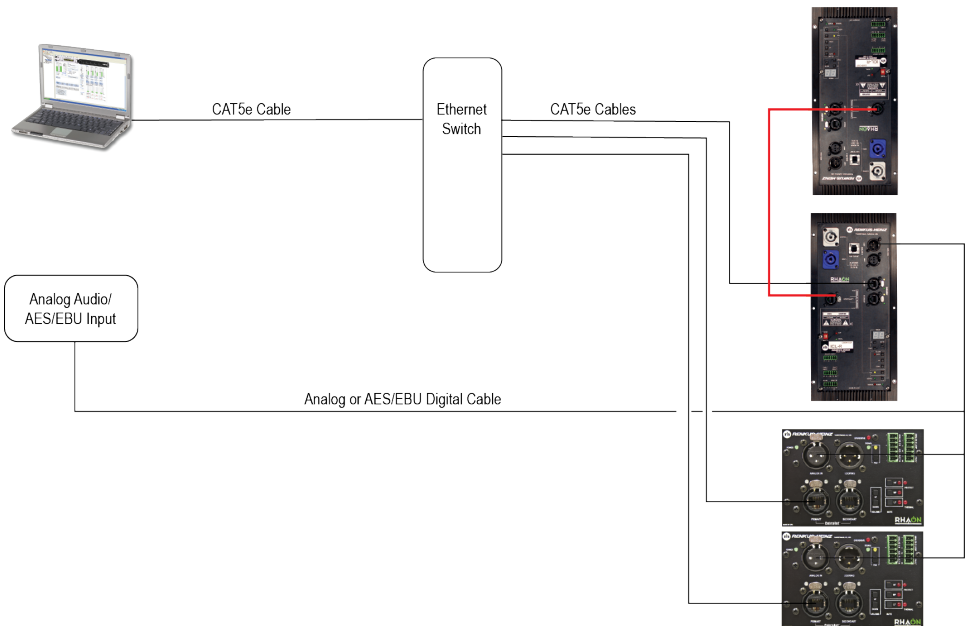

Array Connections

The ICL-R array and IC215S-R Subwoofer Input/Control panels are shown below.

**ICL-R  
Control Panel**

- Looping AC Power Connector
- 90/260 V AC Power Connector
- Master/Slave Link Cable Connectors
- Master/Slave Setup Switches
- Signal Present & Clip Status Indicators



- Analog 1 - AES/EBU Input Connector
- Looping Analog -AES/EBU Connector
- Primary & Secondary Ethernet Input Connectors
- Preset Controls
- Operating Controls
- AES/EBU Input Selector

**IC215S-R  
Input / Control Panel**

- Analog 1 - AES/EBU Primary Input & Looping Output
- Primary & Secondary Ethernet Input Connectors



- Analog - AES/EBU Secondary Input
- Mute Controls
- Level Controls

**IC215S-R  
Power Control Panel**

- Power On / Off



- AC Power Connector

Notice that on both the ICL-R and IC215S-R the Analog and AES/EBU inputs share common input connectors. The AES/EBU Input Selector switches the amplifier between Analog and AES/EBU input modes.

Important: If you are working with a stacked array and one or two subwoofers, make sure your power source (power strip) is adequate to handle the power drain. A stacked array will draw up to 13 Amps at 120 Volts and each IC215S-R needs a 15 Amp source.

## Operation With No PC

This portion of the Users Guide assumes that all input connections have been made and that you are not using CobraNet digital audio for the program source. If you are using CobraNet Digital Audio, refer to Pages 28, 29 & 30 for detailed instructions.

Note that if you are working with a stacked array, the Slave module is controlled by the Master module and most of the Slave's controls will be inoperative. Your connections need to be made to the lower Master module. You also need to make sure the CAT5 linking signal cable and the short AC power cable that links the two modules together are in place.

We'll start with a system that will be run without a computer.

1. Plug in the power cord(s) and turn on AC power to the Array. The ICL-R does not have a power switch. However it can be placed in or out of Standby with the Volume Up and Volume Down push buttons. To change hold both buttons down for several seconds. The Power LED will glow when the amplifier is On.

2. Check the preset digital readout display to make sure the correct preset is selected. On single ICL-R arrays:

**Preset 10:** is factory installed and locked to "Flat" for use in transducer testing and should not be used during normal operation.

**Preset 11:** is factory installed for small venues needing a 50' throw, but not locked and may be changed

**Preset 12:** is factory installed for venues needing a 75' throw, but not locked and may be changed

**Preset 13:** is factory installed for venues needing a 100' throw but not locked and may be changed

**Presets 14, 15, 16, 17, 18 & 19** are set aside for user installed presets.

On dual (stacked) ICL-R arrays;

**Preset 20:** is factory installed and locked to "Flat" for use in transducer testing and should not be used during normal operation.

**Preset 21:** is factory installed for venues needing a 100' throw, but not locked and may be changed

**Preset 22:** is factory installed for venues needing a 125' throw, but not locked and may be changed

**Preset 23:** is factory installed for venues needing a 150' throw, but not locked and may be changed

**Presets 24, 25, 26, 27, 28 & 29** are set aside for user installed presets.

Note: Graphic displays of the Presets can be viewed on pages 12 & 13.

3. If the right preset isn't selected, use the Up & Down push buttons to select the desired preset. Then press the Enter button. The display will flash while the new Preset is being loaded and return to a steady glow when the procedure is complete. If by accident, you select an empty Preset, the dots following the numbers will flash to show no preset is being loaded (no preset is available).

4. If you will be using an AES/EBU digital signal, make sure the AES/EBU input has been selected. The status LED will be glowing green if it is selected.

5. Check the setting of the Input Pad. The pad should be inserted if your analog input source has a high output level. When On, a 10 dB pad is inserted into the input circuit enabling the amplifier to handle input levels of up to + 24 dBu. The yellow LED will glow when the pad is inserted.

6. Set the amplifier's output level using the Volume Up & Down push buttons. Notice that when you are using these buttons, the digital readout will display the level setting in dB. You can also mute the output by pressing the Mute button.

**Important: The factory presets do not include any EQ, high or low frequency shelving, delay or compression. These can be added to the presets using a PC equipped with RHAON. Refer to page 17 for details.**



**Presets ICL-R**

**Preset 11**

ICL-R with a 30 degree opening angle and a -2.27 degree aiming angle; suggested for venues with 50' deep audience areas.

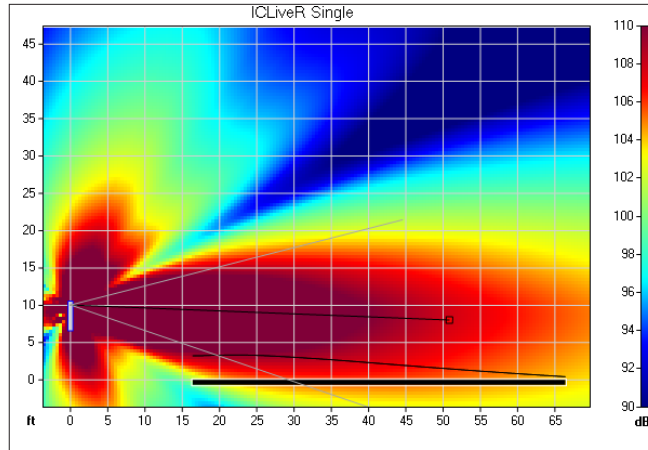

**Preset 12**

ICL-R with a 25 degree opening angle and a -1.53 degree aiming angle; suggested for venues with 75' deep audience areas.

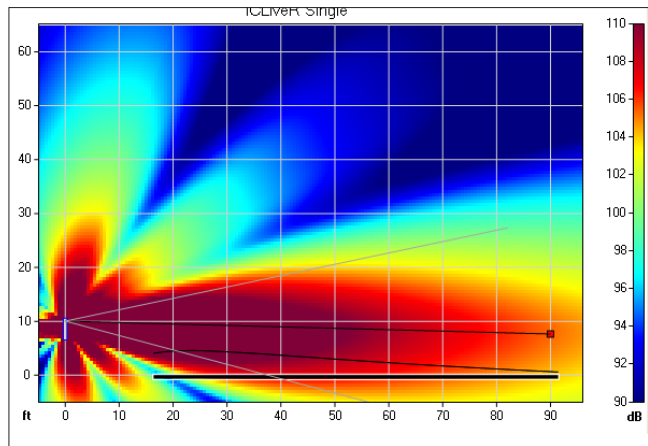

**Preset 13**

ICL-R with a 20 degree opening angle and a -1.14 degree aiming angle; suggested for venues with 100' deep audience areas

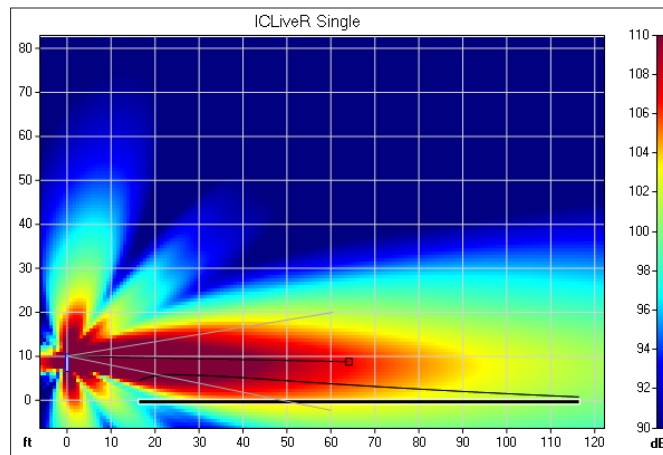

**Presets (Stacked ICL-Rs)**

**Preset 21**

Stacked ICL-R arrays with a 20 degree opening angle provides better control and higher sound levels in venues with 100' deep audience areas than a single ICL-R array.

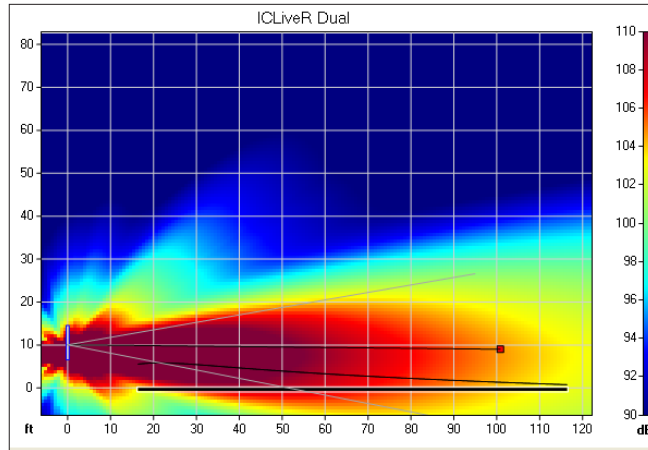

**Preset 22**

Stacked ICL-R array with a 15 degree opening angle. Suggested for venues with 125' deep audience areas.

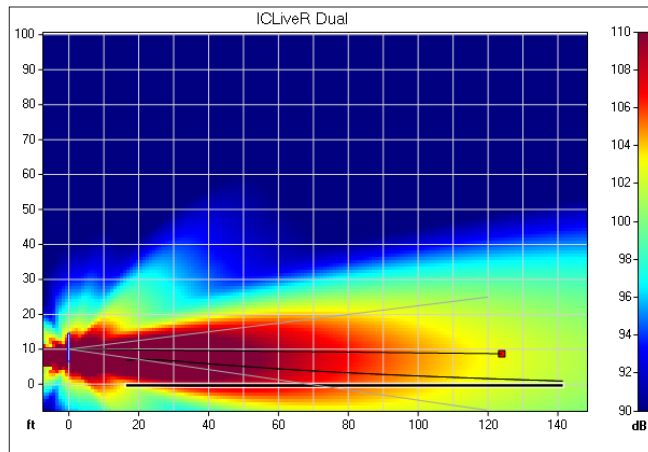

**Preset 23**

Stacked ICL-R array with a 10 degree opening angle. Suggested for venues with audience areas more than 125' deep.

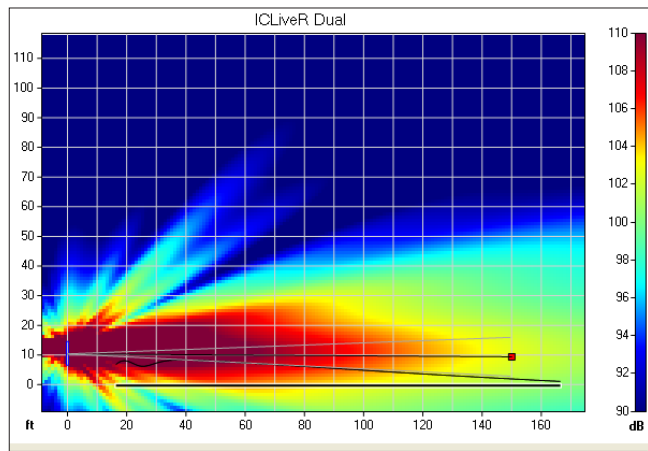

### Computer Controlled Operation & Supervision

Now, it's time to look at a system using RHAON for computer control and supervision. Your computer will have to have RHAON installed on it. If it doesn't, turn to page 22 for installation and setup instructions.

You also need to be aware that even if RHAON is installed on the computer you are using, you may not have access to all its features. RHAON includes several levels of password protection to prevent inadvertent or unauthorized changes of the control settings and you may be denied access to some or all of the control settings. For more details on RHAON and password protection, please refer to page 46.

As soon as RHAON is connected to the network it will scan the Ethernet network for any connected loudspeakers and list them in the Network sub-directory in the directory tree. Use your mouse to drag each loudspeaker listing into the work space where it will show up as an Icon.

Double clicking on the Icon will open that array's Connect Properties window where you can check or change the array's input selections. ICL-R arrays have provisions for two Cobranet inputs, two analog audio inputs and a serial audio (AES3) digital input. Selecting the input you want is as easy as clicking on the desired radio button.

The square Signal Present indicators turn green whenever a signal is present. The 10 dB Pad in the Analog 1 input inserts a 10 dB pad into the Analog 1 input, allowing input signals of up to + 24 dBu. Without the pad, the input clips at +12 dBu.

Pressing the Beams / Presets tab will open the Beam Steering section of RHAON and allow you to check what Preset configuration is selected or to select a new Preset.

Selecting either the Control or Supervise tabs will change the loudspeaker icons in the work space by adding 4 control buttons to each Icon. They allow you to turn the array On or Off(Standby), wink the array's wink light to help you identify it in multi-array setups, mute its output and tell when it the loudspeaker loses signal.

Double clicking on the loudspeaker icon will open the array's Supervision window which allows you to see at a glance how the array is performing and adjust its input gain (output level). You can also mute its output and turn the array On or Off (Standby).

Opening the Control window gives you access to the loudspeakers Parametric EQ, Compressor and Delay controls.

The usual method of monitoring a multi-array system during a program is to watch the array icons in the workspace. Green status bars mean everything is fine, yellow bars indicate the array is being over driven, red bars indicate a problem has been detected. Double clicking on that array's icon will open its supervisory window and provide more details on the problem.

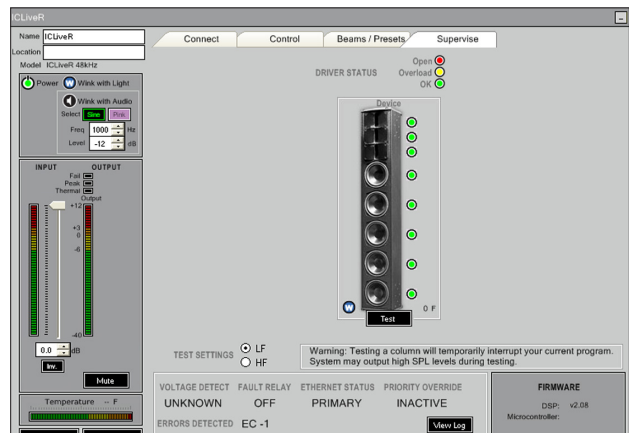
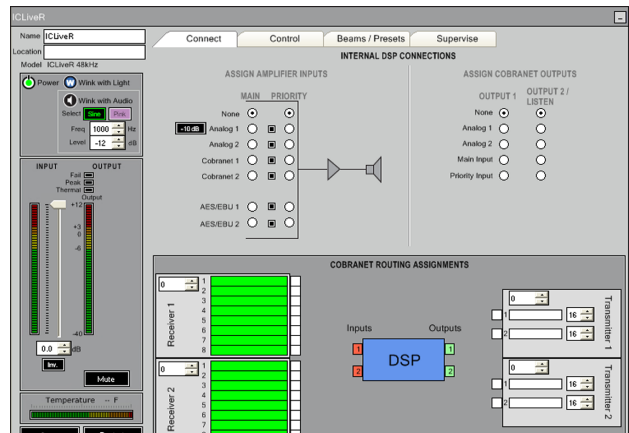
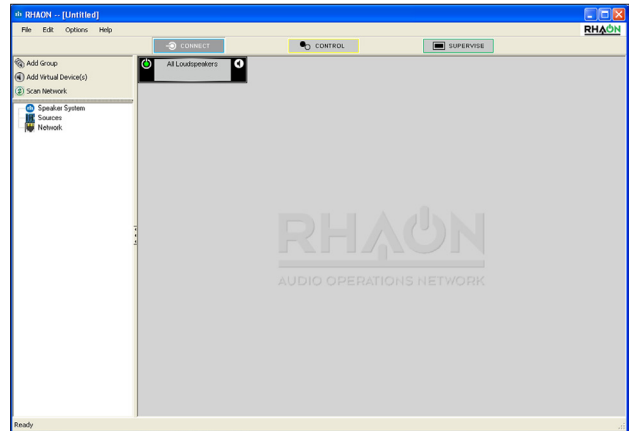

Single array systems can be monitored either with their icon or by viewing the vertical control pane section in one of their property windows. You may have noticed that the vertical control pane is the same in all three of the Properties windows

A detailed description of the vertical control panel's features and functions follows.

Listing of the loudspeakers model number.

loudspeaker's DSP sample rate (either 48 kHz or 96 kHz). See Updating DSP Firmware on page 52 for more details.

Power button switches the amplifier(s) between On and Standby. (turning AC power on and off is an entirely manual operation).

Text fields for entering a name for the loudspeaker and listing its location.

Press Wink with Light button to turn the loudspeaker's wink light on and off to aid in identifying the loudspeaker and its location.

Press Wink with Audio to send a Tone signal or Pink Noise to the loudspeaker.

Output status indicators for each amplifier. See Status Indicators below for details.

Input signal level bar graph; "0" indicates the onset of input clipping. Analog inputs clip at +12 dBu without the 10 dB input pad, +24 dBu with the pad.

Output bar graph. "0" represents the maximum uncompressed output level; positive values indicate how far the signal is overshooting into limiting; negative values indicate the amount of headroom left before the onset of limiting.

Volume control slider; adjust by grabbing slider with mouse or by using up/down arrows. Settings adjustable from "0" to -50 in 1 dB steps, then to -100 dB in one step; settings below -8 dB prevent the loudspeaker from reaching full output.

Inv. button inverts the input signal polarity; glows green when signal is inverted. Use with caution.

Mute button mutes the entire loudspeaker.

Amplifier temperature indicator and bar graph.

Save button

Press to restart the loudspeakers DSP in the event of a malfunction.

**Status Indicators:** The Thermal, Peak and Fail indicators above the output meter provide critical information on the array's status. The Peak indicator will flash yellow or red whenever the device's peak limiter is triggered. It's normal for the indicator to flash occasionally if the loudspeaker is being used close to its rated output. Flashing frequently is a sign that the system volume needs to be turned down. The Thermal indicator will start to flash yellow as the amplifier temperature approaches a preset level and will turn red if the temperature continues to increase as a warning the amplifier is about to be shut down. The Fail indicator glows red when the amplifier has been shut down by the protective circuitry. Heat related shutdowns will reset automatically after the amplifier cools down to a safe temperature.

As a further protective measure, the amplifier's gain will gradually be reduced in response to overheating and/or to a high an input level. However, it's best to manually reduce the input signal level (overall system volume) in response to distress signals.

**Power Button:** Note that the Power button will not show while operating in the virtual world. It appears only when associated with an actual array.

**Computer Controlled Operation (continued)**

**Assigning Digital and Analog Inputs**

The larger right portion of the Properties windows vary with the operating mode. The Connect window is divided into an upper light grey Internal DSP Connections section and a lower darker grey CobraNet Routing Assignments section.

The Assign Amplifier Inputs portion of the upper section is where you select which one of the Array's multiple inputs will be routed to the Main input and which one will be used for the Priority override circuit. RHAON Empowered loudspeakers have provisions for two CobraNet digital audio inputs, two analog audio inputs and a serial audio (AES3 format) digital input. Selecting the input is as simple as clicking on one of the radio buttons.

Notice that the Analog 1 input includes a 10 dB pad. In the On position it inserts a 10 dB pad into the Analog 1 input, allowing input signals as high as +24 dBu. Without the pad, the analog inputs clip at +12 dBu.

The square Signal Present indicators turn green whenever a signal is present.. You can activate any of the analog and CobraNet digital inputs in the upper group. If you select either of the AES/EBU inputs in the lower group, all Analog and CobraNet inputs are disabled.

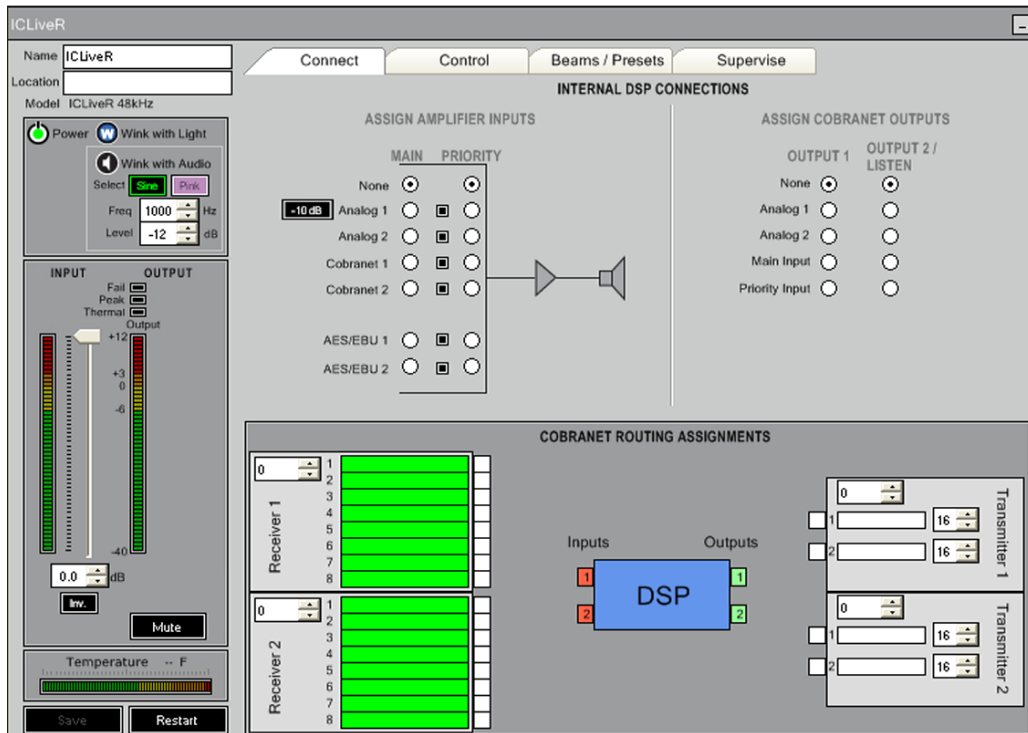

The right hand Assign Cobranet Outputs portion of the upper section lets you use any of the audio inputs or amplifier outputs as an output to the CobraNet network, except for the AES/EBU inputs. AES/EBU signals are clocked separately from CobraNet and cannot be output to CobraNet from RHAON.

The lower CobraNet Routing Assignments section is where you select which CobraNet input channel you want to use and set up the output transmitter.

You can use RHAON to Control and Supervise your system without using digital audio distribution via CobraNet, or you can combine digital and analog signal distribution for redundant signal path and/or life safety applications. However, if you use AES/EBU serial digital inputs, all other audio inputs are automatically disabled.

If you will be using CobraNet for digital audio distribution in your RHAON system, additional details on this feature can be found on page 28.

## Computer Controlled Operation (continued)

### DSP Control

The Control properties window includes controls for an 8-band Parametric EQ complete with High and Low pass band shelving filters, plus controls for a compressor, signal delay and several other user configurable DSP functions.

Opening the Control window allows you to tell at a glance what EQ, if any, has been installed into the array's DSP and change it if needed. Remember, the presets installed at the factory include only beam steering information. They do not include EQ, delay or compression.

The filter controls are underneath the frequency chart. To activate a filter, click the button above its white data fields; then either type in your values or use the up-down arrows or scroll with your mouse to adjust the parameters. At the far left is a high pass filter; its low pass counterpart is at the far right. These filters have three controls: Cutoff Frequency, Type (Bessel, Butterworth, etc.), and Slope. The pair of filters to the inside are shelving filters, with controls for corner frequency and boost/cut.

The center section gives you control of 8 fully parametric filters, with controls for center frequency, boost/cut and bandwidth in octaves. When you activate a filter, its button turns green and it appears on the graph – each filter appears in a different color. A solid white line shows the overall EQ curve. The Bypass All button at the bottom of this section lets you compare filtered and unfiltered signals quickly.

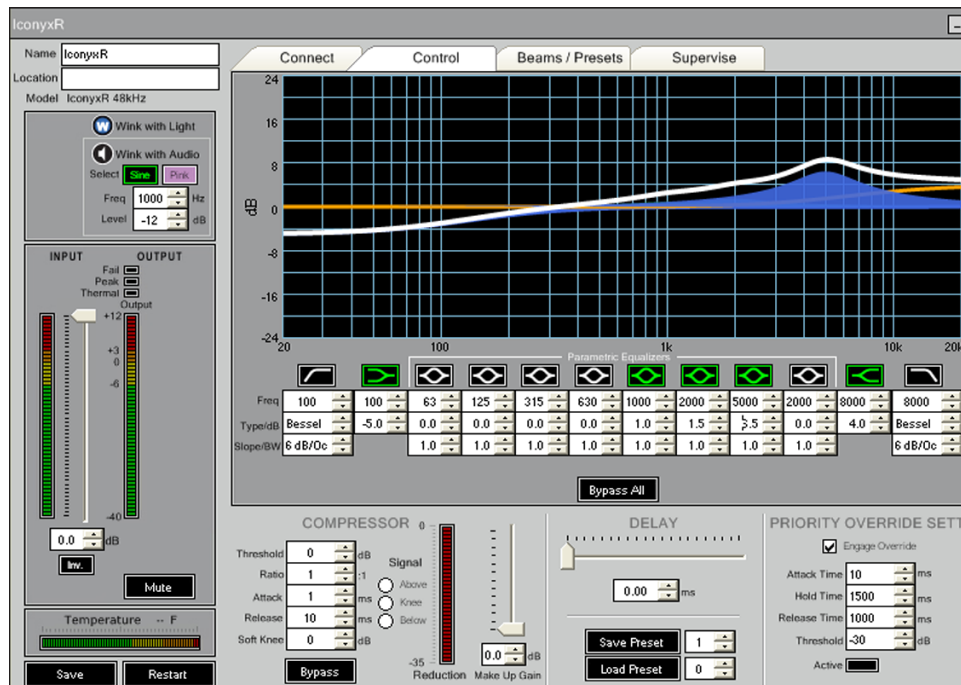

**All filter parameters can be controlled with the scroll wheel on your mouse. Click inside the control field and scroll to set: Gain, Bandwidth, Frequency, etc.**

Below the EQ section in the light grey area, you'll find controls for the Compressor on the left. The controls – Threshold, Ratio, Attack Time, Release Time and Soft Knee – are similar to the EQ controls. You can type in values, use the Up/Down buttons, or scroll with your mouse to find the values you want. Under Signal you will find buttons that set the compressor's trigger point Above, At or Below the Knee.

When the compressor is operating, the Bypass button is red and the Gain Reduction meter on the right side of this section lights up. To turn the compressor off or to compare the uncompressed output to the compressed output, click the Bypass button. To the right of the compression Reduction Meter is the Make-Up Gain control. This control can be used to restore RMS levels of the compressed signal to those expected of the signal pre-compression. It has a range of 0 to +12 dB.

The arrays input module's DSP has 340 milliseconds of signal delay available, if you are using the 48 kHz sample rate; 170 milliseconds if you are using 96 kHz. Use either the up-down arrows or the slider control to adjust the delay time.

Computer selection of Presets is accomplished in the Beams / Presets window.

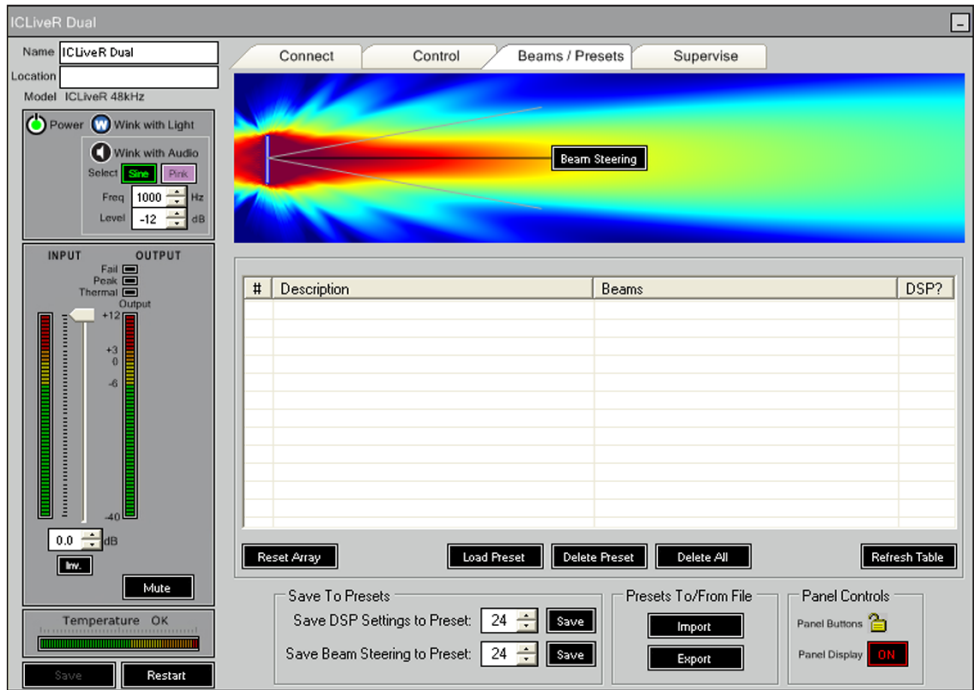

If you are operating in the virtual mode (no array connected) the white Presets field will be blank. When an array is connected, the listing fields will be populated with a list of the Presets stored in the Array’s memory and a green bar will indicate which preset, if any, is loaded into the array. See below.

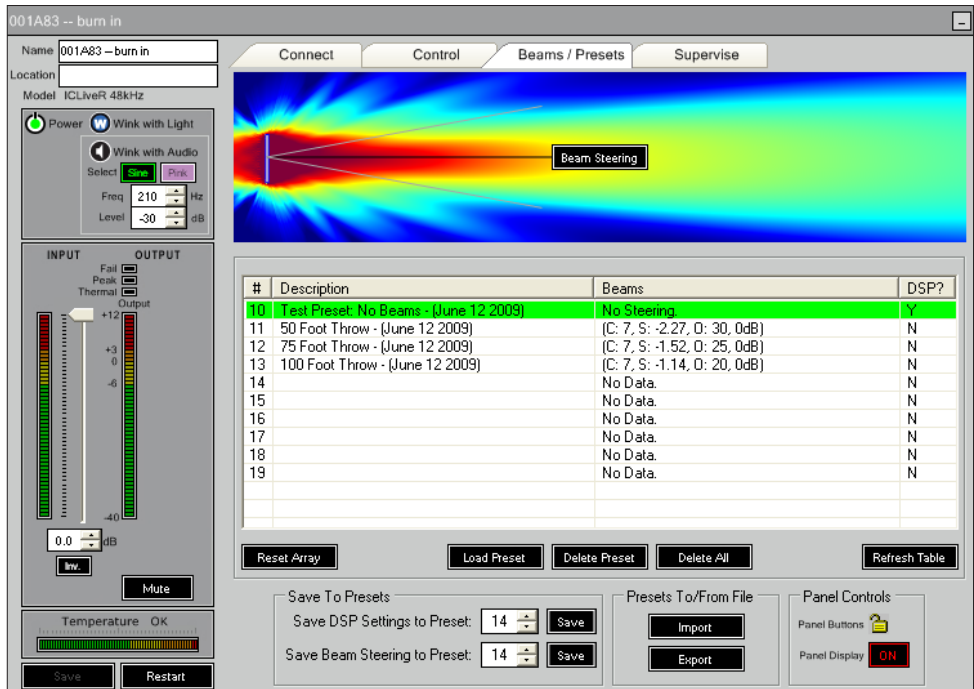

The Steering column in the Preset window contains steering information on the Preset. The C: figure identifies the acoustic center location, the S: figure the aiming angle, the O: figure the opening angle and the final numbers the amount of attenuation assigned to the beam. The DSP? column shows whether or not the Preset includes DSP data (EQ settings for example).

### Load Preset

The Load Preset control and its associated up/down arrows are used to select and install (load) a specific Preset into the array's DSP memory.

If no DSP data is included in the Preset, a dialog box will call the lack of DSP data to your attention and ask if it is OK to proceed. Answering Yes, will initiate the process, introduce a Loading Status screen and hide the lettering in the Beams / Presets window. The Loading Status window will disappear and the lettering will reappear when the process is complete.

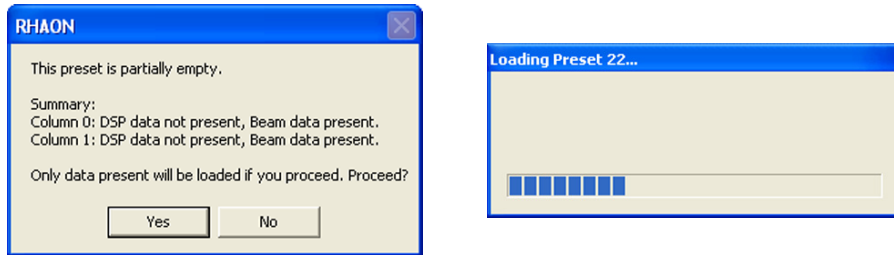

### Controls

Most of the buttons at the bottom of the window provide additional control over Presets.



The Panel Controls serve different functions. Clicking on the Panel Display control will turn the Preset digital readout display on the rear of the array On and Off. The display is often turned off during a performance to prevent the readout's red glow from being a distraction. The button will say On in red when the readout is turned On. Note that the digital readout can also be turned On and Off using the Preset Up and Preset Down push buttons on the array's control panel. Pressing both of these controls at the same time toggles the readout between On and Off.

The Panel Buttons control locks all the controls on the rear of the associated array to prevent inadvertent changing of the settings or tampering. The padlock icon will be closed when the controls are locked.

### SysTune Interface

If you are using SysTune as your measurement system during setup and tuning, you can access the array's DSP from within SysTune.

This allows you to take a measurement, adjust the EQ settings and then view the result of the changes in real time within one program and on one screen -- no more jumping back and forth between programs and windows.

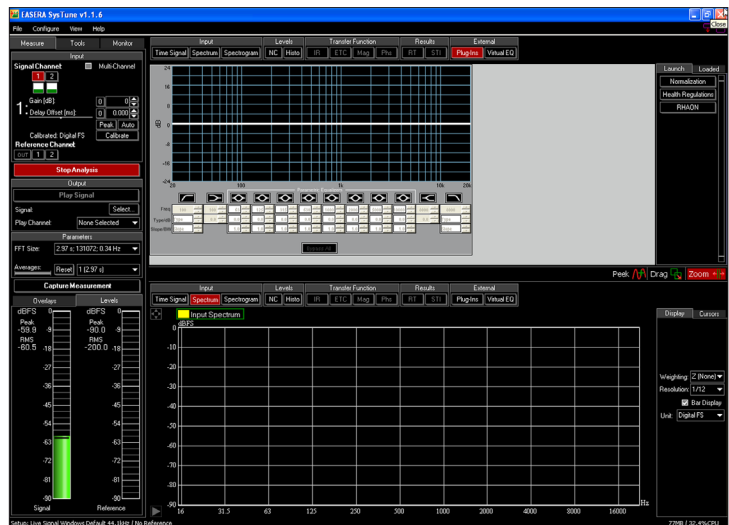



## Additional User Information

## Section 2: Advanced Setup Instructions

### Initial Setup

#### Computer Requirements

You need a Windows PC running RHAON software in order to maximize the performance of RHAON empowered loudspeakers and your RHAON system. You can use RHAON software during the design stage, for system setup, tuning and commissioning, and for remote control and supervision. You can disconnect the computer from the network after commissioning the system, if you or your client are not using RHAON's system supervision capabilities.

RHAON software will run on any PC computer that meets or exceeds the following requirements.

Processor / Speed:	Pentium / 800 MHz minimum (faster recommended, especially for large systems)
RAM:	256 MB minimum (more recommended, especially for large systems)
Interface:	At least one Network Interface Card (NIC) with a 100 BaseT (100 MB/second) or faster Ethernet Port; two NICs are needed if the computer will also be used to e-mail alerts
Operating System:	XP, Vista, Windows 7 and Windows 8 with either 32-bit or 64-bit processors
Associated Software:	NET Framework 3.5 or higher (supplied with RHAON installation CD)
Screen Resolution:	1024 x 768 or higher

#### Installing RHAON

To install the software insert the RHAON Installation Disk into the computer's CD drive. The installation program should start automatically. During the installation you will need to select either the 32-bit or the 64-bit install.

**RHAON 1.10.2 is downwards compatible with earlier versions of RHAON Microcontroller and DSP firmware so you do not need to uninstall a previous version of RHAON before installing program version 1.10.2. However, new program features may not function in loudspeakers running earlier versions of firmware.**

If the installation program does not start automatically, go to your Start menu. Then select Settings/Control Panel & Add/Remove Programs. Click on Install to start the installation manually. The RHAON Setup window will open. Click on Next to proceed to the next step. Then follow the screen prompts until the installation is complete.

Notice that the program warns you if your display settings may cause viewing problems. If you are using "Large Fonts," we recommend you change to the default 96 DPI setting to avoid possible viewing problems.

The installation program will install RHAON in a Renkus-Heinz/Rhaon folder on your hard drive. It will not uninstall earlier versions of RHAON. Use Settings/Control Panel and Add/Remove to uninstall an earlier version if you want to delete it.

The RHAON Installer puts a RHAON Icon on your desktop. Double click on it to open the RHAON software program.

The grey background of the opening RHAON can easily be changed to something more useful, such as a block diagram of your system or a photo of the venue. To change the background, go to the Options pull-down menu and select Background Image/Load Image. Then browse to the drawing or photo you want to use. Be aware that the photo or drawing you import needs to be of approximately the proper size and shape before importing.

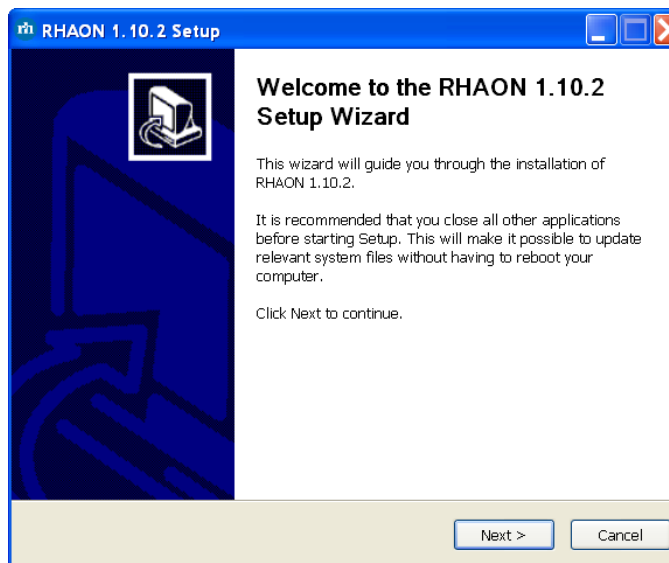

## Assigning a Static IP Address to the RHAON Host Computer

Your RHAON equipped computer communicates with the arrays in your system over an Ethernet network and must have an NIC (Network Interface Card).

The first step is to make sure the computer's Network Interface Card (NIC) is properly setup. Your NIC must have a static IP address assigned to it: This enables the RHAON software to communicate to all the loudspeakers on the network.

Each device on the RHAON/CobraNet network must have a unique IP address in order to communicate. RHAON software can assign the IP addresses to your networked loudspeakers automatically.

If you are running Windows XP, go to the Start Menu and select Control Panel/Control Panel and Network Connections. If you are using Vista, Windows 7 or Windows 8, go to Start/Control Panel/All Control Panel Items/Network and Sharing Center.

Find the connection you wish to use. It will likely be called "Local Area Connection" unless you have renamed it. Also, make note of the model number of the NIC you will be using. The RHAON software will require you to use it later. Right click on the connection line/icon and then select "Properties" to open its Properties window.

Then, double click on Internet Protocol (TCP/IP) to open its Properties window. You will probably see that your computer is configured to "Obtain an IP Address Automatically". Change this to "Use the Following IP Address" and enter an IP address of, for example 192.168.1.1. Next, insert 255.255.255.0 into the Subnet Mask field. Click OK and you are ready to connect to the RHAON/CobraNet network.

**Note:** IP addresses are in the format xxx.xxx.xxx.xxx where "xxx" is any digit from 0 - 255. Local IP addresses that appear only to other devices on a LAN (Local Area Network) are defined as ranges 192.168.xxx.xxx, 172.16.xxx.xxx to 172 and 10.xxx.xxx.xxx.

**192.168.xxx.xxx is the range most commonly used and we suggest you use it unless you have a good reason to use another range.**

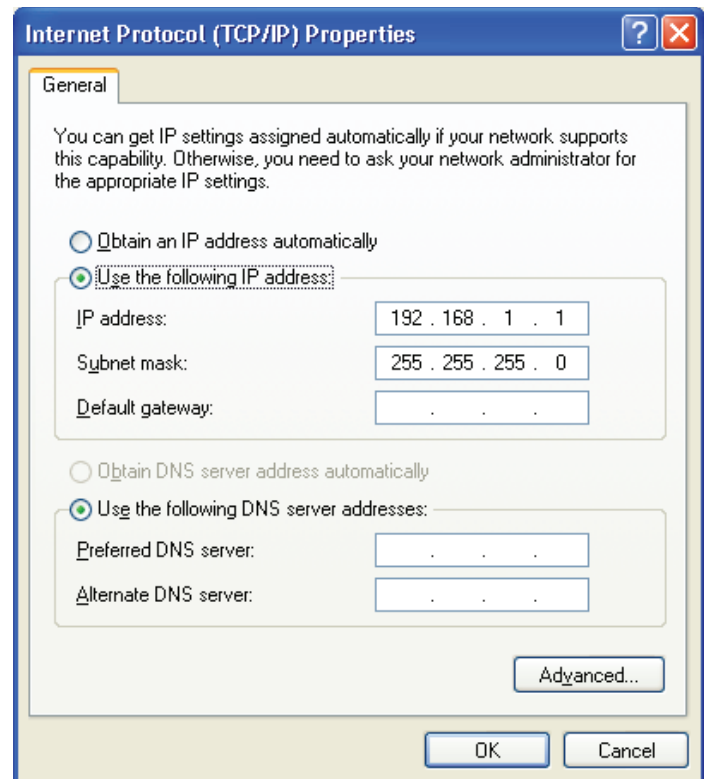
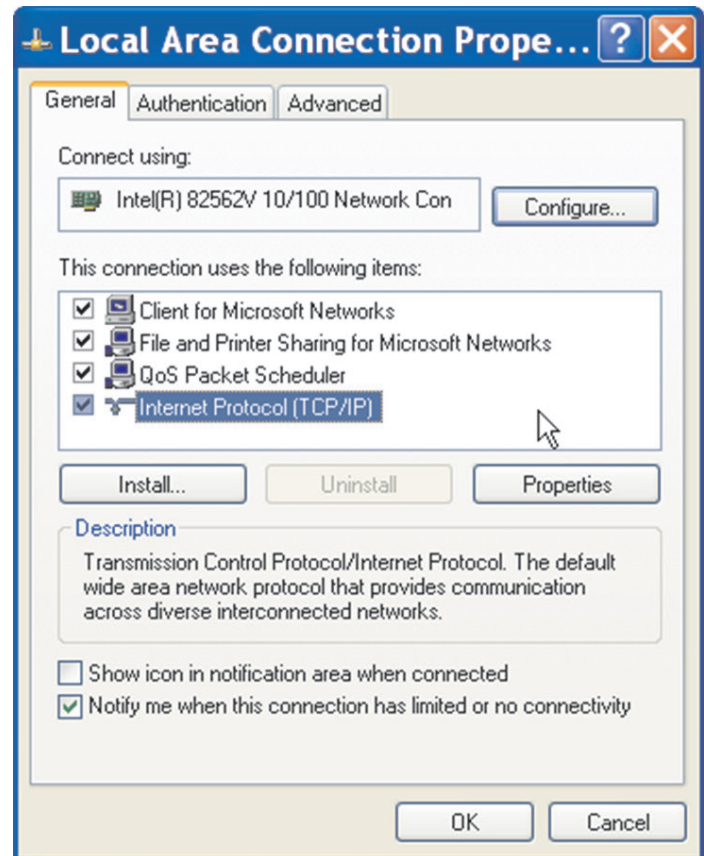

Before connecting your computer's to the Ethernet network, you need to make sure that RHAON has the correct network settings. Open RHAON, go to the Options menu and select "Preferences". on the General tab, make sure the correct NIC is selected in the Adapter field. It's the one you assigned an IP address to while you were following the directions on the previous page.

Each device on the RHAON/CobraNet network must have a unique IP address in order to communicate over the Ethernet network. RHAON software can assign IP addresses to all these devices, but before RHAON can do this you need to specify a range of IP addresses for RHAON to use.

The static address assigned to the computer in Windows sets the "subnet" you will be using. A subnet is the first three parts ("octets") of the IP address. In the example, the subnet is 192.168.1. Therefore, all the IP addresses on the network will be in the form 192.168.1.xxx.

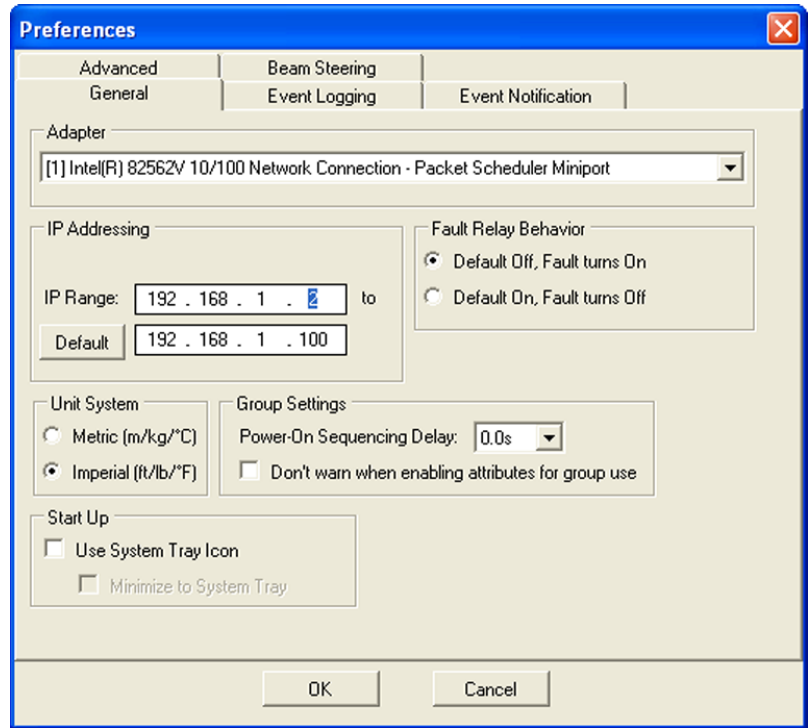

You need to define the range of IP addresses RHAON will scan. Type two valid IP addresses into the two IP Addressing fields: one for the lower limit of the range and the other for the upper limit. Since 192.168.1.1 is already in use by the RHAON host computer, the lower limit must be at least 192.168.1.2. The upper limit can be set as high as 192.168.1.255, but needs to be only high enough to accommodate all the devices on the network. Remember each device must have its own IP number.

After specifying the range of IP addresses that RHAON will assign to the loudspeakers click OK and connect the computer to the RHAON/CobraNet Ethernet network, i.e., plug in the CAT5 cable.

### The Network Manager

Most Iconyx IC-R and ICL-R / ICL-FR setup and installation problems are "network problems" and not Iconyx or RHAON problems. Your Iconyx array was factory tested before it left our factory and barring shipping damage should be in perfect operating condition. The RHAON Network Manager allows you to check the integrity of the Ethernet network before you actually link to the loudspeakers. It is accessed from the File pull down menu and identifies network problems for you before you waste a lot of time checking out the loudspeaker.

In the example shown here the ICL-FR Left obviously has a network communications problem while the CF61 DBL and the VoiceBox are suspect. For more details on the Network Manager refer to page 57.

Age	MAC#	IP	Name	Description	Startup IP	Errors	Error Code
750	001bde00080a	192.168.1.5	PN1R-Burn in ra...	RH RHAON 48kHz PN102/LAR v1.40 CobraNet version 2.11.6 CS496112	0.0.0.0	0	--
609	001bde000946	192.168.1.17	4409-2935 Hou...	RH RHAON 48kHz Iconyx v2.12 CobraNet version 2.11.11 CS496112	0.0.0.0	0	--
672	001bde000947	192.168.1.19	4409-2936 Hou...	RH RHAON 48kHz Iconyx v2.06 CobraNet version 2.11.6 CS496112	0.0.0.0	0	--
531	001bde000b12	192.168.1.15	ICL-FR Left	RH RHAON 48kHz ICL-FR v2.34 CobraNet version 2.11.12 CS496112	0.0.0.0	2248..	34
828	001bde000de7	192.168.1.16	CS49611	RH RHAON 48kHz Iconyx v2.12 CobraNet version 2.11.11 CS496112	0.0.0.0	0	--
375	001bde001260	192.168.1.4	CF61 DBL	RH RHAON 96kHz CF81-2R v1.40 CobraNet version 2.11.6 CS496112	0.0.0.0	20	61
141	001ce200052f	192.168.1.21	VoiceBox	Attero Tech VoiceBox 4 I/O CobraNet version 2.11.6 CS496112	0.0.0.0	69	113
219	00602b0402c8	192.168.1.23	Suitcase B0B	Cirrus Logic EV-2/CM-2 (CM18101) CobraNet version 2.11.6 CS496122	0.0.0.0	0	--
453	00602b0402dc	192.168.1.3	Carl's B0B	Cirrus Logic EV-2/CM-2 (CM18101) CobraNet version 2.11.6 CS496122	0.0.0.0	0	--

## Virtual Systems

From time to time you may want to create a virtual system within RHAON to verify that you have selected the right equipment for the venue and to work out the beam settings before taking the equipment to the site.

To create a virtual system, open RHAON and select Add Virtual Devices. When the Add New Speakers dialog screen opens, use the directory tree to select and add the Array(s) you want to work with and then click on Done.

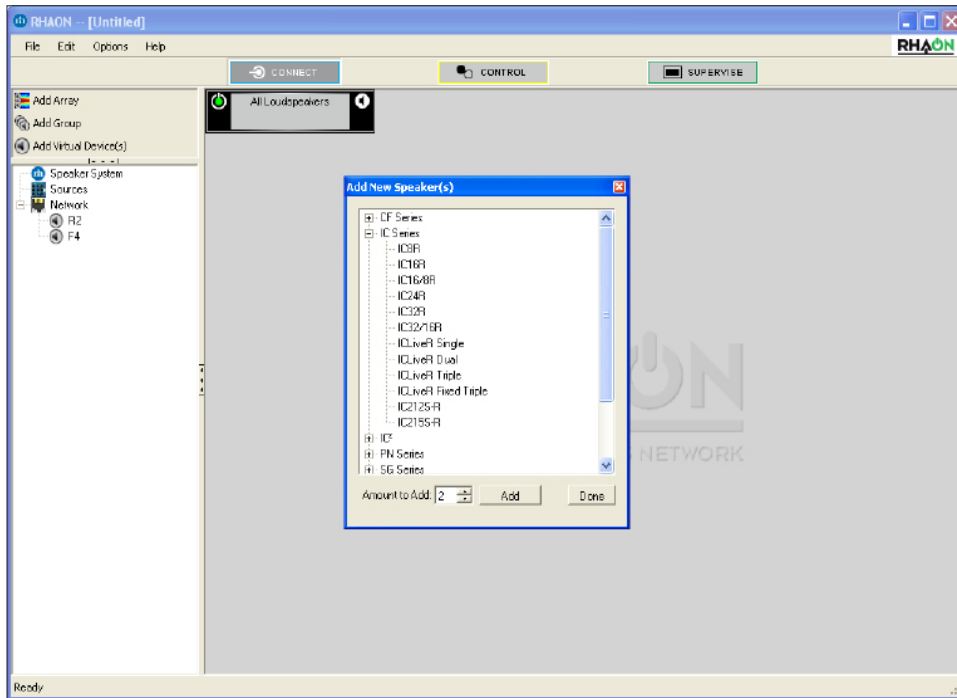

The program will then place icons for the Array(s) you have selected into the work space.

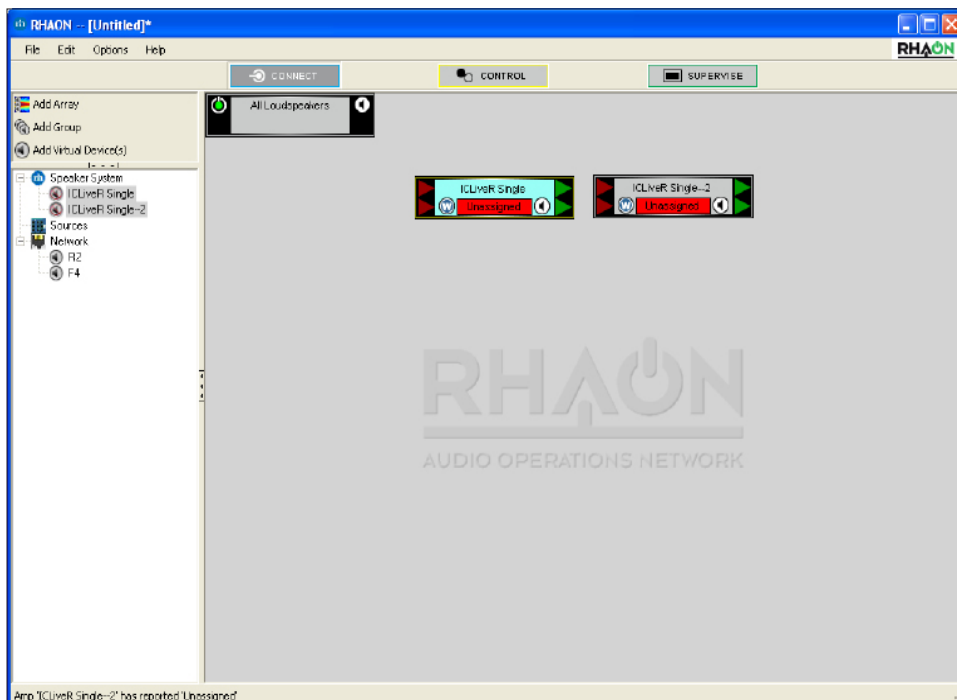

Double clicking on one of the array icons will open its Connect properties window.

At this point you can set up the inputs in the Connect window and by moving to the Control window set up the array's control parameters, just as you would if you were working with a real array.. The only difference is that any setting changes will be saved to a project file and not to the array.. These settings can then be loaded into the array at the job site over the Ethernet network.

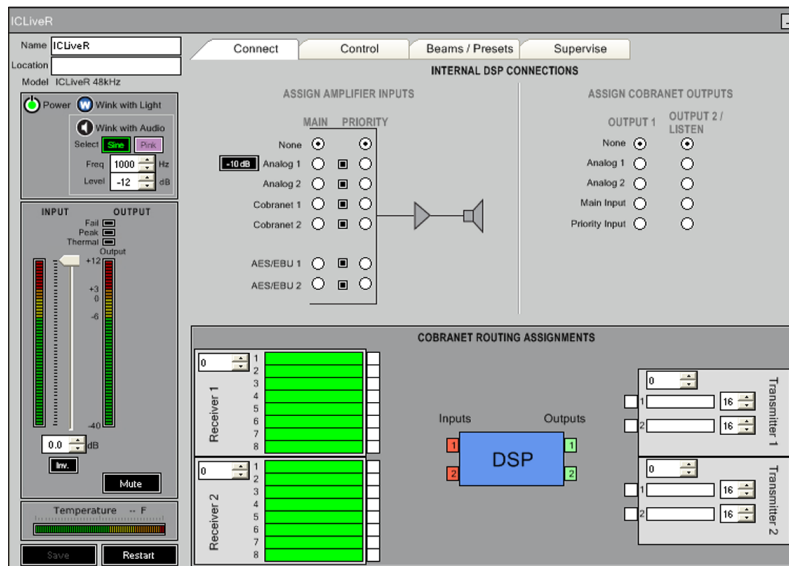

### Linking Software Icons With Networked Arrays

To link the virtual array(s) you created in RHAON to the actual array(s), connect your computer running RHAON software to the network and click on Scan Network. RHAON will find and identify all the arrays on the network and automatically assign them IP addresses . RHAON will also identify any other CobraNet devices or RHAON empowered loudspeakers on your network and list them along with the array(s) under the Network sub-directory in the directory tree.

Drag each individual array listing from the Network sub-directory into the main work space and drop it on the appropriate icon.

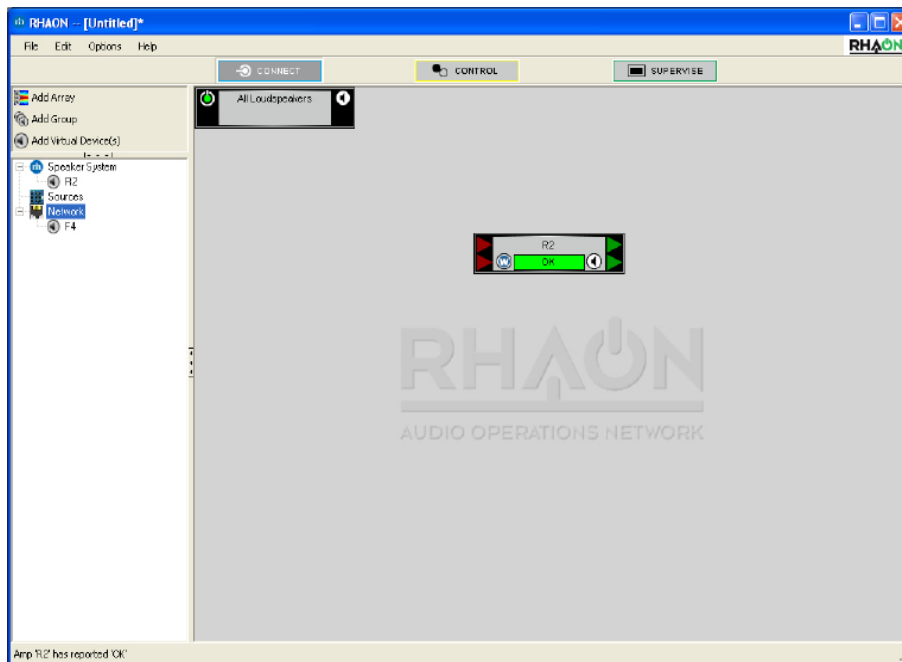

Notice that when you dragged the listing onto the icon the listing in the directory tree moved from the Network sub-directory to the Speaker sub-directory.

If RHAON can't find any CobraNet devices on the network, the prompt shown to the right will appear to let you know that something is wrong and to offer trouble shooting hints. For more detailed trouble shooting instructions please refer to page 54.

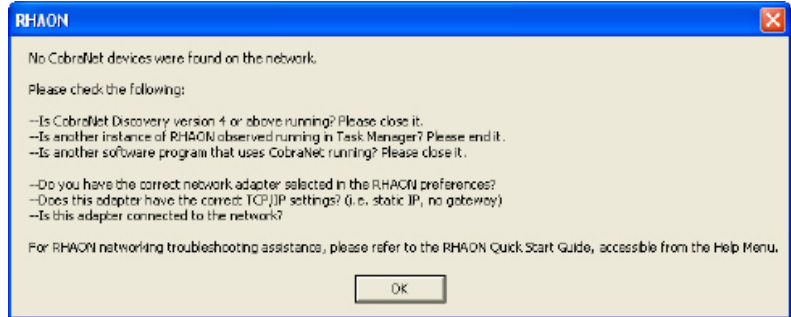

When you link a networked loudspeaker with a software icon, RHAON interrogates the loudspeaker to make sure the DSP settings stored on your computer are synchronized with those in the loudspeaker's onboard memory.

If they are not, RHAON displays a prompt that allows you to choose which settings to use. To upload settings from your computer to the loudspeaker, click on Overwrite Settings on DSP. To copy the loudspeaker settings into the project file, click on Read Settings from the DSP.

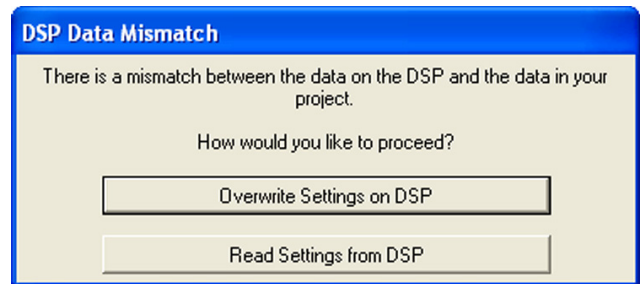

If you were linking an existing project on your computer into an existing network, the dialog box shown to the right will appear and you will need to decide which settings you want to use, the ones stored in your project file or the ones present in the loudspeakers.

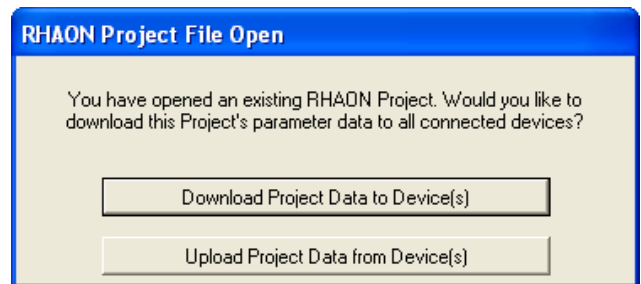

Continue until all networked loudspeakers are linked to icons in the main workspace. When an icon is linked to a networked loudspeaker, the status indicator under its name changes from Unassigned (Red) to OK (Green).

To confirm that the setup is complete, return to the directory and place the cursor over the loudspeaker listings in the directory tree.

As you can see from the pop up screens, RHAON has assigned IP numbers to each of the loudspeakers.

Note that you also could go to the Network Manager to check the IP number assignments. It would provide you with a complete list of all the devices on the network and their IP numbers.

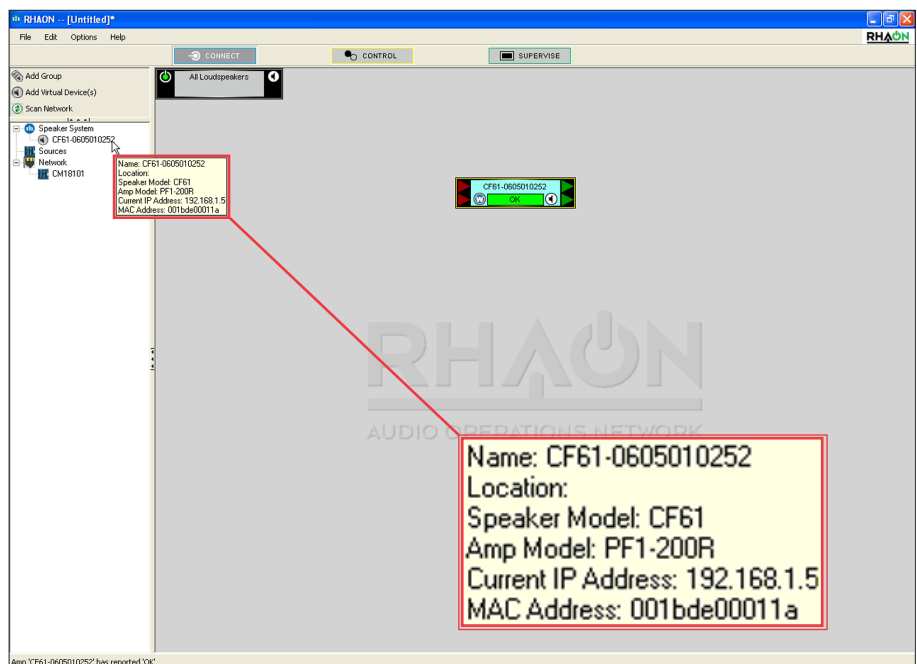

## CobraNet Signal Routing

CobraNet devices transmit and receive digital audio (48 or 96 kHz, 16, 20 or 24 bit) in bundles of up to 8 channels. The number of channels per bundle can vary, depending on latency and resolution settings. The number of bundles available depends on network bandwidth. Each CobraNet bundle has a number from the following ranges:

- 0: Disables the receiver or transmitter.
- 1 thru 255: Multicast mode (many receivers can access the same bundle).
- 256 thru 65,279: Unicast mode (allows only one receiver to receive the bundle).

In order for CobraNet devices to communicate, their Tx (Transmit) and Rx (Receive) bundle numbers must match. RHAON software makes this easy. In some cases the settings of a CobraNet source will have already been established with the source's own proprietary software and can be changed only with the manufacturer's software. However, if the manufacturer's software allows it you can set or reset both receiver and transmitter bundle settings of any device found on the CobraNet network using RHAON software.

The first step in setting up CobraNet routing is to scan the network and then drag the CobraNet Source that was detected by Scan Network into the work space.

The CobraNet Source and the devices connected to it must have the same Sample Rate and Latency settings. Right clicking on the CobraNet Source Icon will open a pop up screen showing the Sample Rate and Latency settings. We suggest you accept the Source's default settings unless you have a specific reason to change them.

You will then want to check the device settings to make sure they are the same as the Source's settings. The settings must be the same for the source and for all devices connected to it.

While latency may be changed here via point-and-click, the sample rate is pre-programmed in the DSP firmware running in the loudspeaker. You can switch the sample rate only by uploading the appropriate firmware to the loudspeaker.

Please refer to page 52, "Updating DSP Firmware" for information on how to upload new firmware to your device.

Next, check the bundle settings of the CobraNet Source device. The Source in our example has 4 Receivers and 4 Transmitters. The red triangles on the left of its icon represent Rx bundles and the green triangles represent Tx bundles. Right clicking on one of the triangles will open a pop up window that shows the bundle number and allows you to change it.

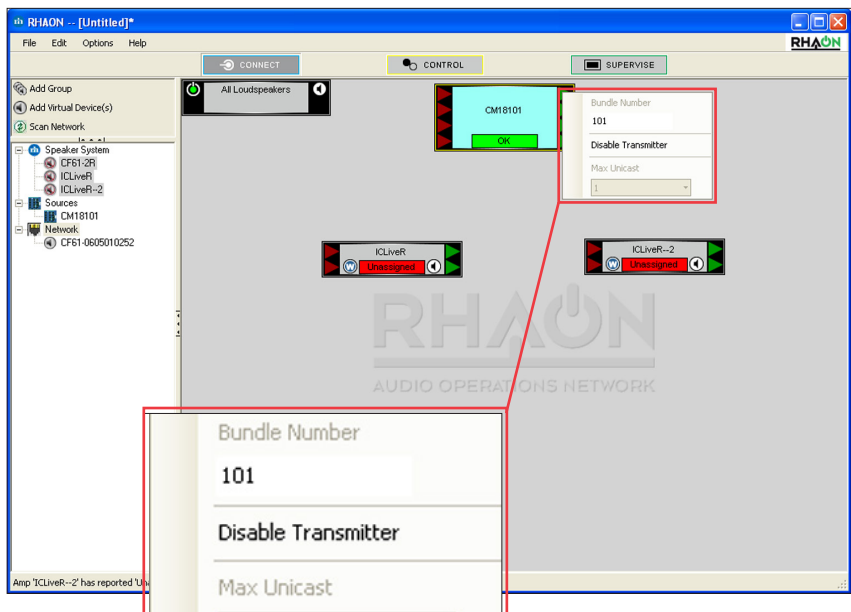
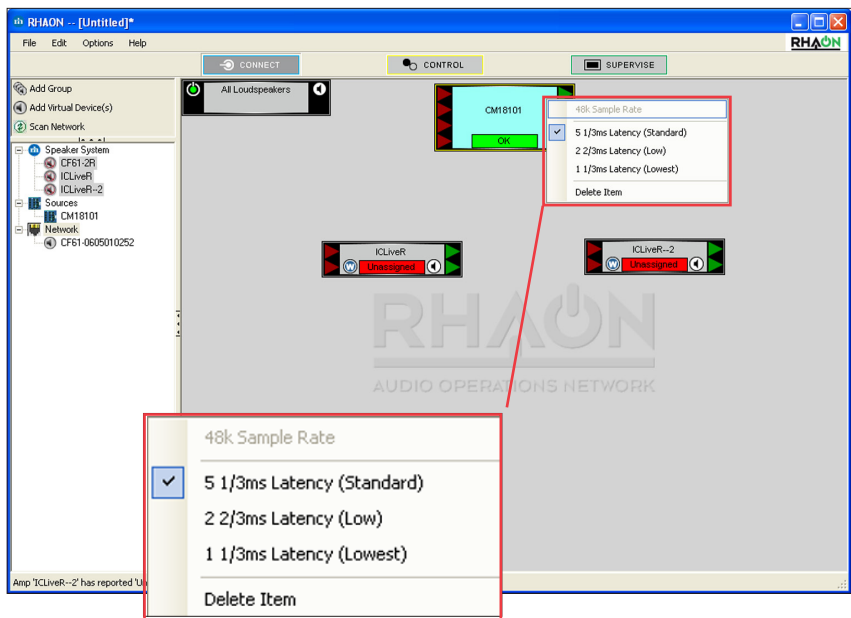

The next step is to connect the CobraNet Transmitters in the Source to the CobraNet Receivers in the RHAON loudspeakers. Double click on one of the Source's green Tx triangles and then double click on one of the loudspeaker's red Rx triangles to connect the two. A connection line will let you know the connection was completed. The loudspeaker's Receiver automatically inherits the bundle settings of the Source Transmitter. Keep repeating these steps until all the loudspeakers are connected.

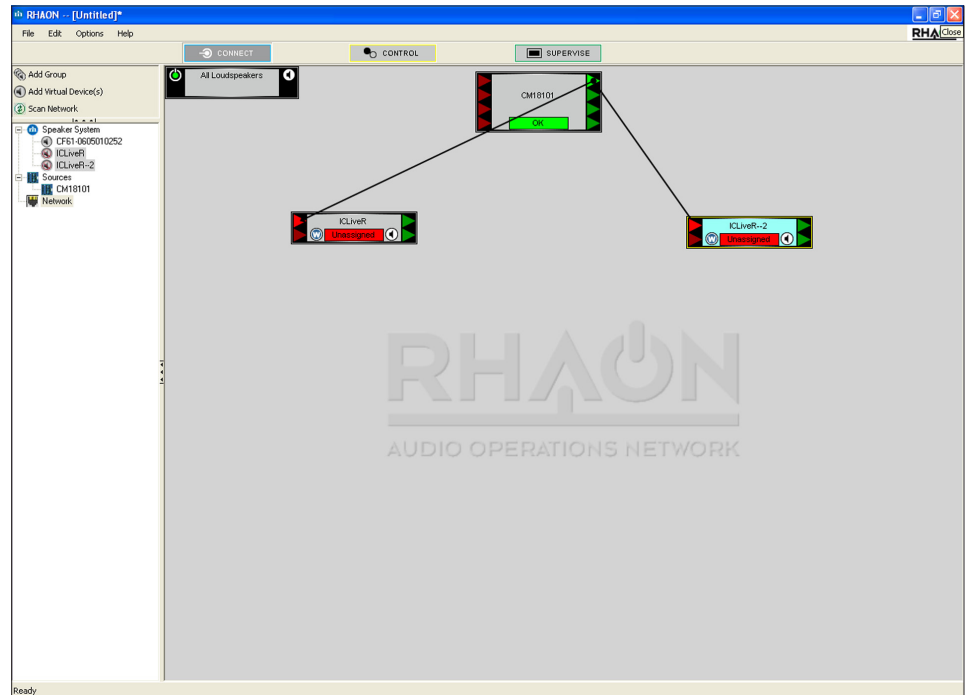

To correct a mistake or change an assignment, double click on the Receiver whose assignment you want to change or right-click on the Receiver Icon and select Disable Receiver from the menu that pops up. Either method will break the connection and allow you to make a new one.

Since each CobraNet bundle can carry 8 channels of digital audio, you must make channel selections individually.

Once your Tx and Rx bundle assignments have been made, open each loudspeaker's Properties window by double-clicking its icon. If the window does not open in Connect mode, click on the Connect tab at the top to display the window shown at the right.

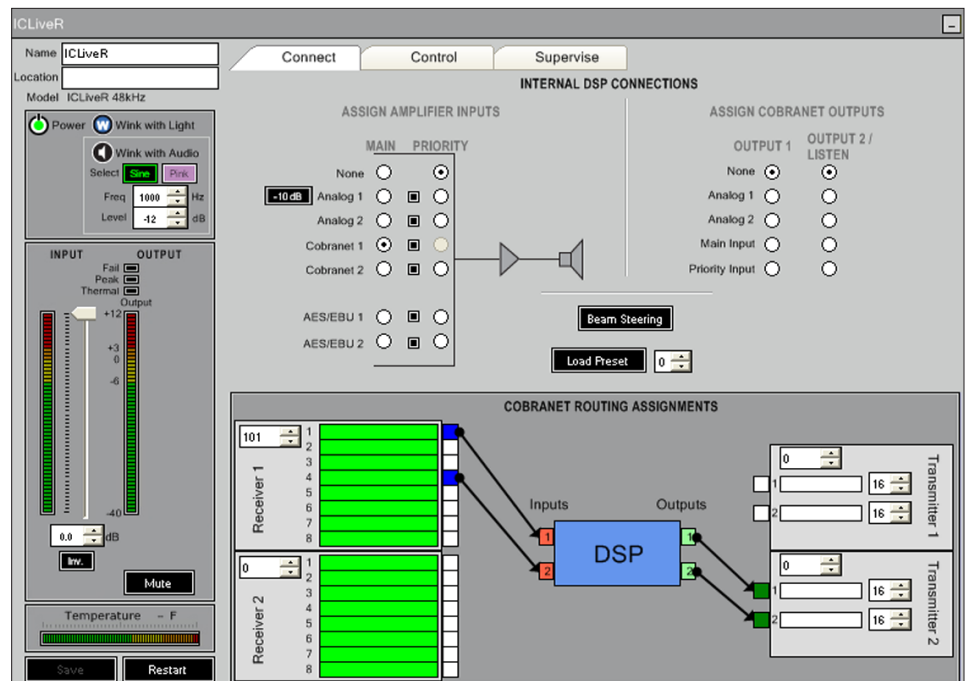

In the lower-right section of this window, you make channel assignments by clicking and dragging to connect audio channels from the CobraNet source to the RHAON loudspeaker's CobraNet Receivers.

You can also assign Outputs 1 and 2 (selected in the upper section under Assign CobraNet Outputs) to the RHAON loudspeaker's CobraNet Transmitters.

## Beam Steering

onyx ICL-R digitally steered arrays produce tightly focused, precisely aimed beams of acoustic energy that maintain their intensity well over long distances. The FIR files that shape and aim these beams of energy are created within RHAON under Beam Steering and then either stored as a Preset or loaded into the array's DSP.

Presets are an Iconyx feature that allows you to store up to 10 preset beam steering and DSP control setup configurations in the array's DSP memory and then select between them. To enter Beam Steering, open the Beams / Presets Tab and click on Beam Steering. This will open the Beam Steering window shown below. Multi module ICL-FR arrays can be configured as either "Master & Slave" or "All Master Arrays". In the Master & Slave configuration one Array module is set up as the Master and all the other modules are Slaves to the Master and give up control of many of their functions to the Master. In the All Master approach all modules are Masters, but they give up control of many of their functions to the Array Icon which serves as the Master.

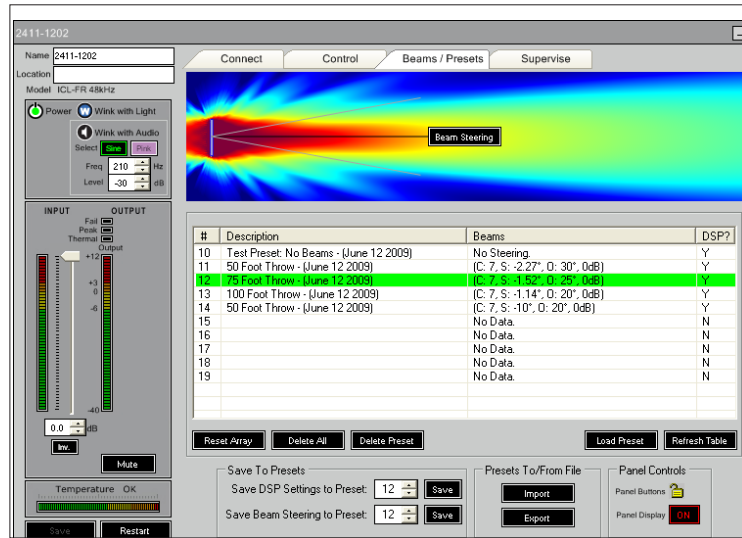

The Master & Slave configuration is the most popular and the following Beamware instructions assume you are working with a Master & Slave system. The only major operational difference is that when you are putting the system together in the virtual world you need to insert a beam into the array before it will initiate Mapping. More details follow on the next several pages.

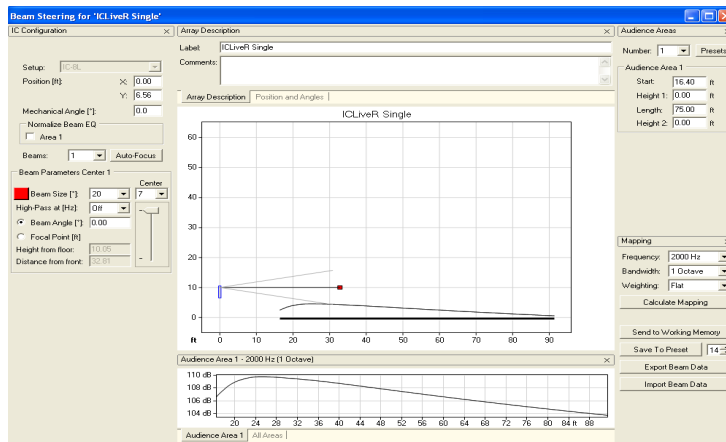

Cabling is a little different. In a Master and Slave system all incoming signal wires terminate in the designated Master and passed through to the Slaves. In the All Master approach, every unit is a Master and requires its own separate signal and control cables

The Master & Slave approach is the most popular and the following Beamware instructions assume you are working with a Master & Slave system. The big difference is in the cabling. In a Master & Slave system all cabling terminates in the Master and is then jumpered up to the Slaves. In an All Master system, every module is a Master and requires its own separate cabling.

The opening Beam Steering window shown on the previous page doesn't show the array's beam. Pressing the Calculate Mapping button and following the prompts tells the program to calculate and display the beam. A typical Map appears below.

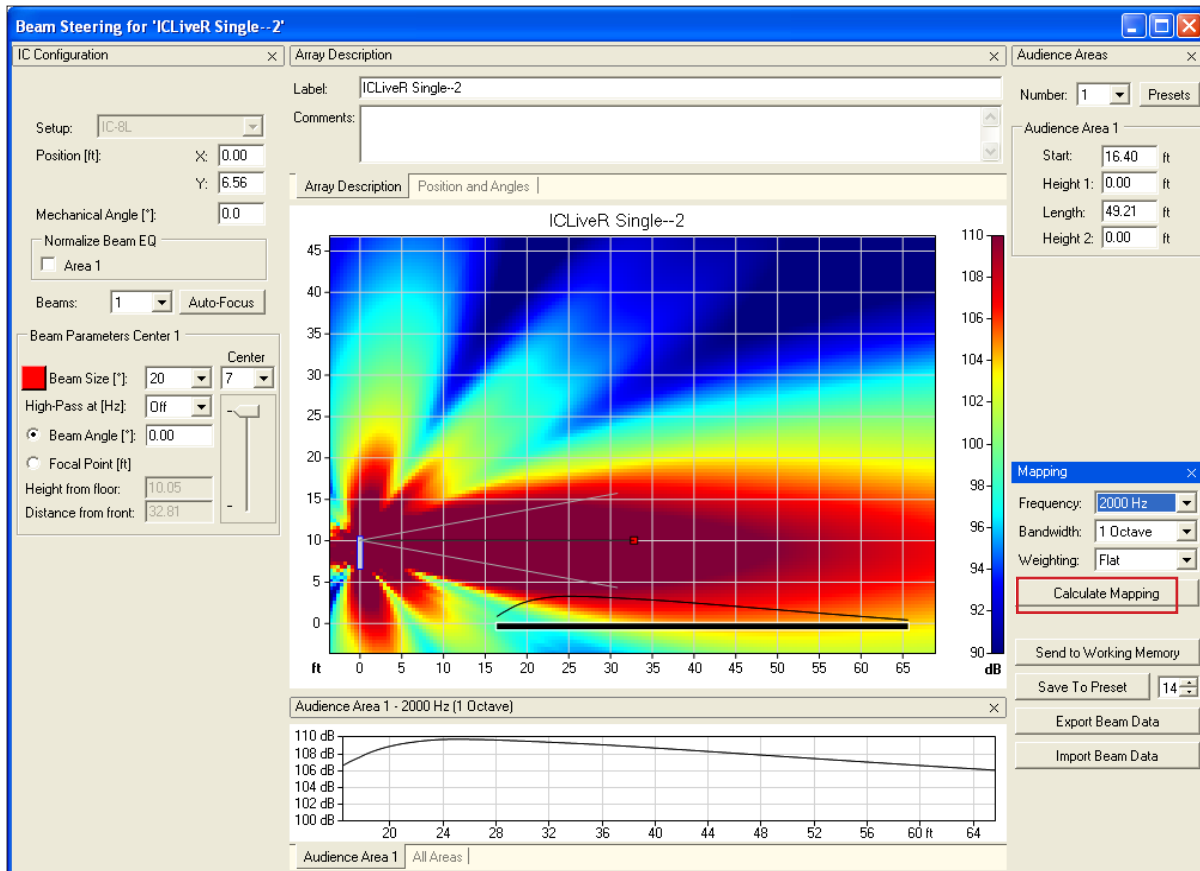

Note the four control buttons in the lower right corner of the Beam Steering window. Pressing Write to Device will send any beam steering configuration setting changes you have made directly to the array's DSP and write over any previous settings.

Pressing Save to Preset will store the configuration settings as a configuration Preset in the selected preset file. We'll go into Presets in more detail later.

Note that in both cases, only the beam steering information is being sent to the Array's.

Export Setup will generate a .rhs setup file that can easily be imported into an EASE and EASE JR model for a detailed acoustic evaluation. Beam Steering shows you the array's vertical coverage, but not the horizontal coverage or the effect of reflections on intelligibility and clarity. EASE and EASE JR do.

Import Setup allows you to import into Beam Steering any changes you may have made in the configuration settings in EASE or EASE JR.

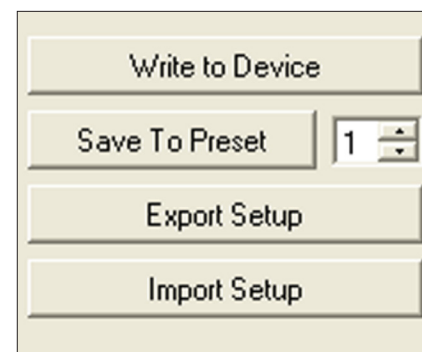

Before going on you should first verify that the correct measurement system is being used (feet or meters). The default measurement system is feet but you may want to use meters.

To check or change the setting, select Preferences from the Options pull down menu in the tool bar section of RHAON or right click in the center of the beam steering window. The Preferences folder will open in the General Tab view

If you want to change from feet to meters, check the Metric radio button.

Note that this window also allows you to control the behavior of the Fault Relay and the Power-On sequencing delay.

The Beam Steering tab contains the setting controls for the appearance of the Beam Steering window. The normal default setting are shown.

Notice that this setup window also allows you to change the height of the measuring plane (the Ear Height). Until you are more familiar with the program we suggest you accept the default setting. There are times, however, when you will want to change the height of the measuring plane. It is set to 1.2 meters (3.94 feet) which is fine for a seated audience, but not for a standing audience. For a standing audience a height of 5.5 feet is commonly used.

The Mapping Appearance section allows you to control the appearance of the main Mapping plot. For now, we suggest using the default settings. You can experiment with various settings later.

The Scale Level Views section gives you control over the scales used in the main Mapping window. Many experienced users like to use the Fixed Range option under Scale Level Views; setting the Round Up to 5 and the Show Range to 5. You may want to experiment with this to see which settings you like best.

We'll investigate the other tabs later.

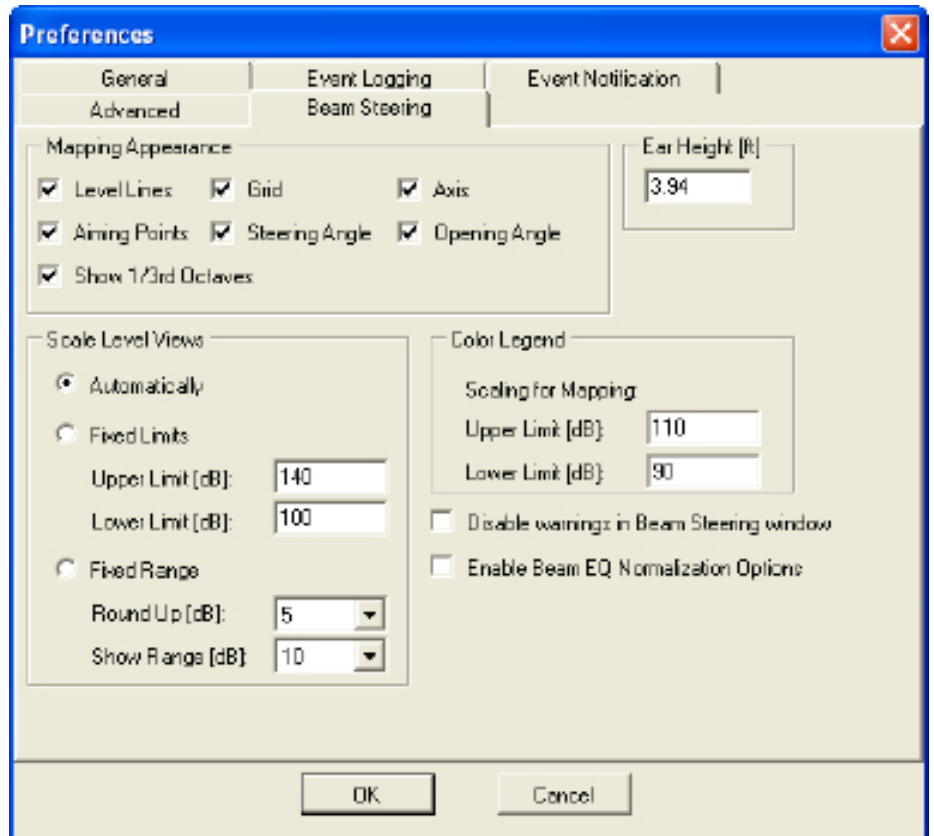
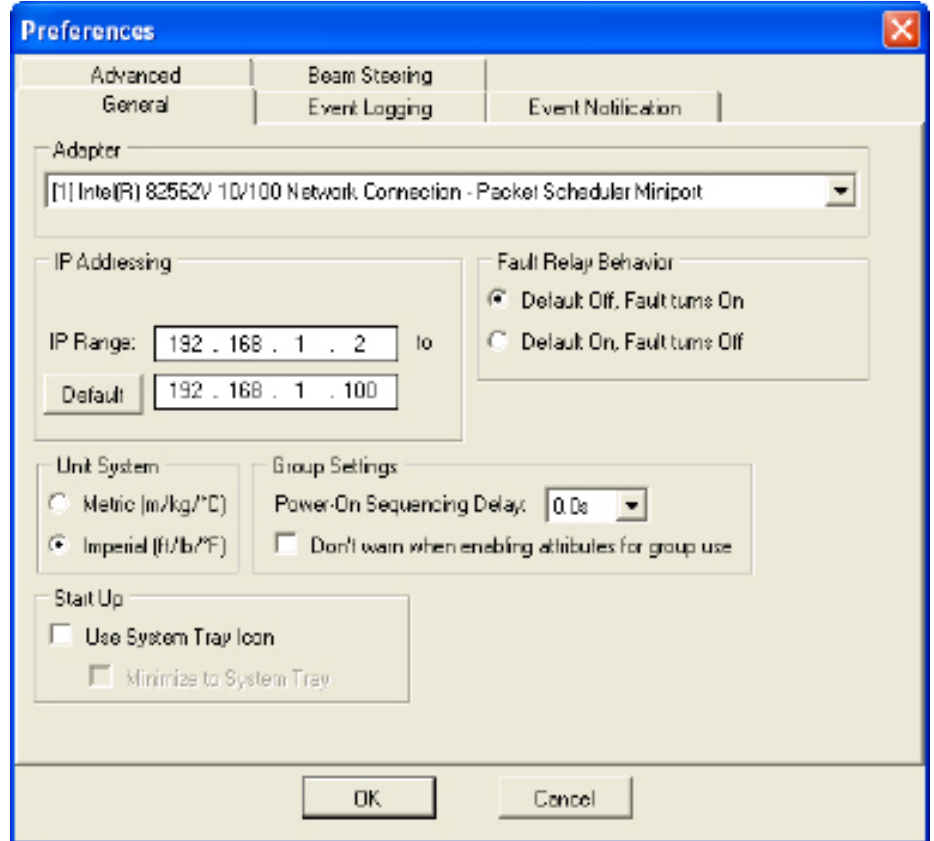

You should know the physical dimensions of the area(s) you want to cover, so the next logical step is to set up the audience area(s) using the Audience Area section on the right side of the Beam Steering screen.

To simplify this step, Beam Steering provides five templates, the Standard one used as the default starting point and four others; Small Arena, Large Arena, Open Air and Theater. These templates are available by clicking on the Area Presets button. You should become familiar with these templates, so we suggest you try each one of them and then choose the one that comes closest to matching your project. Note how the number of areas and the size of the Audience Areas change from one template to another.

Once you have selected the template, alter the Audience Area size(s) and location(s) to match your project's dimensions. Notice that you can also add or delete up to a maximum of 3 Audience Areas by using the Number field and associated drop down arrow.

The Start field establishes the beginning point of the Audience Area relative to the "0" point of the graph. The Start point is usually the first row of seating. Height 1 is the height of the front of the Audience Area. It usually is "0" for the front of the first floor area.

Length is the physical length of the Audience Area from the front edge to the rear edge. Height 2 is the elevation (height) of the rear of the Audience Area above the "0" plane.

The next step is to configure the steerable column(s) you will be using in your project, i.e., to position them, define the beam(s), etc. using the IC Configuration section on the left side of the window. See graphic to the lower right. The down arrow associated with the Setup field allows you to select between arrays in multiple array systems.

Now, it's time to locate (position) the steerable column. Usually it will be on the front wall (X = 0.00) in the beam steering Project display. If it will be placed at the front of the stage away from the front wall, for example, move it forward by inserting its correct location. Note that after you insert a figure in the field, you need to press Enter on your keyboard to OK the change in location.

The Y field controls the height of the column array by positioning the bottom of the column above the Floor level (the "0" level). The default position is 6.56 feet (2 meters). The Mechanical Angle field tilts the column forward or backward (minus [-] numbers tip it back and plus [+] numbers tilt it forward). This parameter is usually left at 0.0 since the normal position for IC Live arrays is flat against a wall and the array's output digitally steered down onto the audience area.

The next step is to choose the number of Beams using the Beams field and its associated drop down menu. One of the unique features of Iconyx steerable arrays is the ability to generate either single or multiple lobes. We'll be discussing multiple lobes later in this tutorial, so for now accept the default 1 beam (single lobe) configuration. Beam Size lets you choose the Array's opening angle which controls the sharpness of the vertical lobe (beam). Try it out using the drop down arrow. Notice how the opening angle of the array in the graphic varies as you choose different opening angles.

The High-Pass at [Hz] control allows you to insert a high pass filter into individual beams. This new Beamware feature is used to balance the system's low, mid and high frequency content to improve intelligibility,

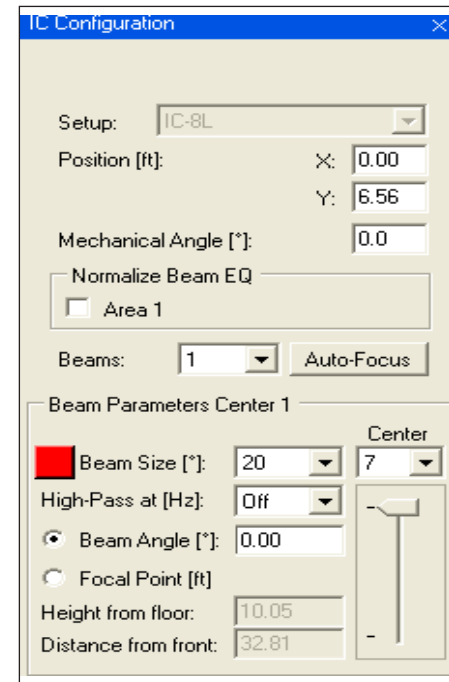
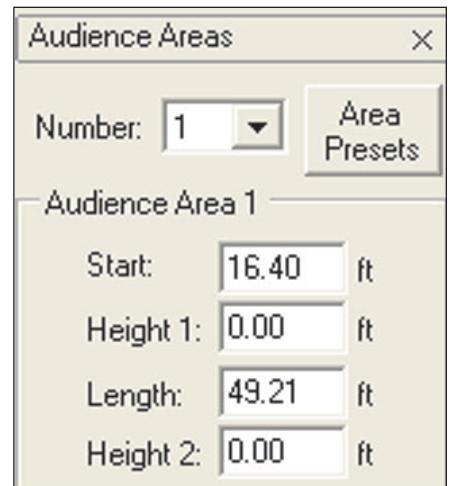
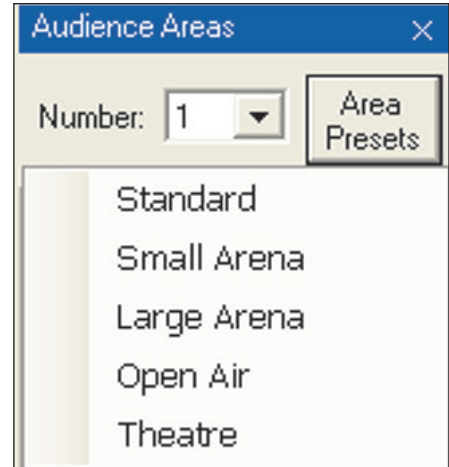

Selecting Normalize Beam EQ instructs Beam Steering to apply a normalized EQ curve to the FIR filters and reduces the amount of EQ that will be needed during final commissioning. Some users, however, prefer to do all the EQ themselves so this feature can be turned off. See Preferences on page 32). This feature relies upon the accuracy of the audience area configuration for its calculations, so be sure you have properly defined the audience area and the location of the array before using it.

Auto-Focus in RHAON 1.10.2 will analyze your project and suggest the number of beams, their acoustic center location, their aiming and relative gain - all at the touch of the Auto-Focus button. We'll explore its use later on.

Note that at any point in the setup process you can click on the Calculate Mapping bar to tell the program to map the array's performance on the audience area.

As soon as you press Calculate Mapping, a pop up screen will ask you to choose the resolution of the simulation. Low Resolution simulations are much faster to run than High Resolution ones. All you need to do to start the simulation is to make your resolution choice by pressing one of the bars.

You also have the opportunity to choose the simulations Bandwidth, its Center Frequency and its Weighting. The Frequency section lets you select center frequencies from 100 to 10,000 Hz. The default selections for the Bandwidth section allows you to run the simulation over 1 octave or 3 octave bands or Broadband.

You can change this by going to the Options window (F9), selecting the Appearance tab and checking Show 1/3rd Octave. This adds a 1/3 octave selection to the drop down Bandwidth menu and the opportunity to set a specific bandwidth for the mapping simulation. In the graphic shown, for example, selecting "to 3150 Hz" would run the simulation over the frequency range of 1000 too 3150 Hz.

We'll choose the default settings for this exercise, but you may want to try out all the different settings to become familiar with them and the performance of steerable arrays.

Beam Angle aims the vertical beam up or down. Try it out by selecting Beam Angle [\*], changing the number and observing its effect. Note that after entering a new number you will need to press Enter to initiate the change. You will also need to do a new Calculate Mapping to view the change. The old map will have been wiped out by the program as you made the change.

You can also check Focal Point [ft] and then enter the exact location of the beam's focal point in Height from Floor and Distance from Front.

Another way to position the beam's focal point is to use the mouse cursor to grab the end point of the aiming axis and move it to the desired location.

Try it out. It's easy to do. The SPL levels in the graphs will change as the setup parameters change.

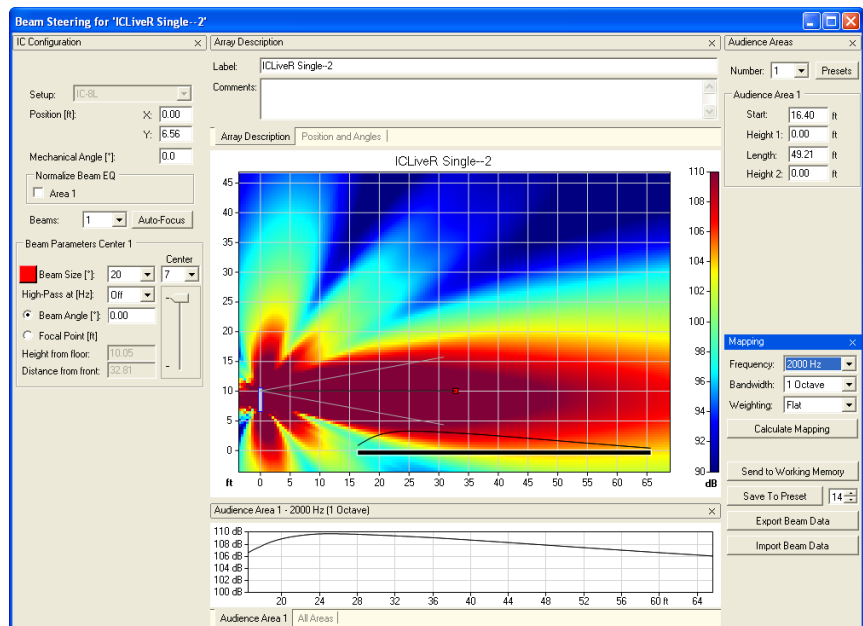
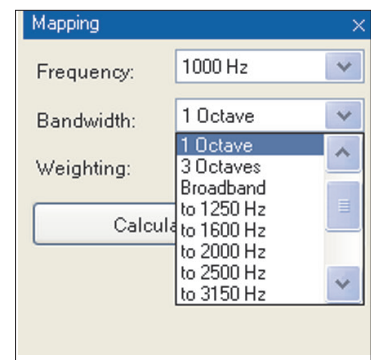
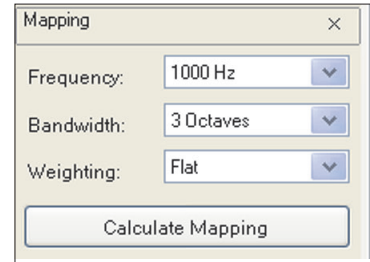

Now, let's investigate the multiple beam capabilities of Iconyx.

In many installations, a single beam is the ideal solution for the room's acoustical challenges. In some cases, however, multiple beams are needed to provide the desired coverage. Rooms with a balcony are a good example; in most cases a single beam can't cover both the main floor and the balcony.

One solution is two line arrays, one for the floor and the other for the balcony, but this is expensive. In other cases, architectural considerations or microphone placement dictate that the column be mounted higher than is ideal and it's impossible to cover the audience area with a single beam.

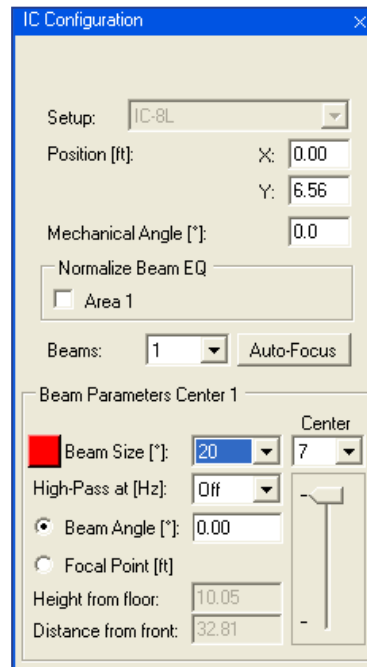

Iconyx solves these problems by offering multiple beams. To explore this unique Iconyx feature, click on the drop down arrow associated with Beams.

Notice that on a dual or stacked ICL-R array you can select up to a maximum of 8 beams. It's up to four on a single ICL-R. For now, select 2 to add a second beam to the graphic.

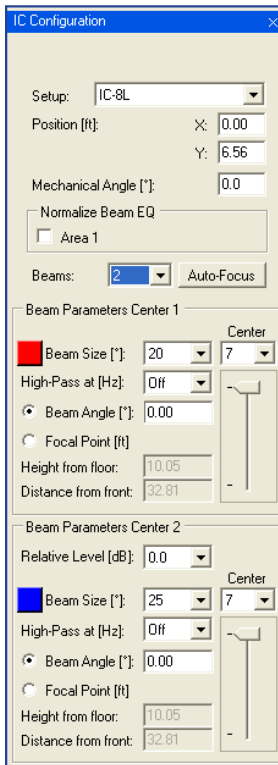

At first glance it may appear that nothing happened since the program may have placed the second beam on top of the first beam. One way to tell that a second beam has been added is that the left side of the window now includes a second Beam Parameter section. Refer to graphic to the left. Notice that the second beam is identified with a dark blue aiming point

Notice that the second beam also includes a Relative Level field. This allows you to reduce the level of this beam relative to the first beam, a useful feature when the second beam is covering the front of the audience area.

The High Pass at [Hz] section lets you add high frequency content to maintain consistent high to low/mid frequency balance throughout the room.

Take a few minutes now to become acquainted with the many design possibilities offered by Iconyx steerable arrays by playing around with the number of beams, their opening angles, their aiming and their relative levels.

One of the things you will notice is that as the number of beams increases, the output level of the individual beams decreases.

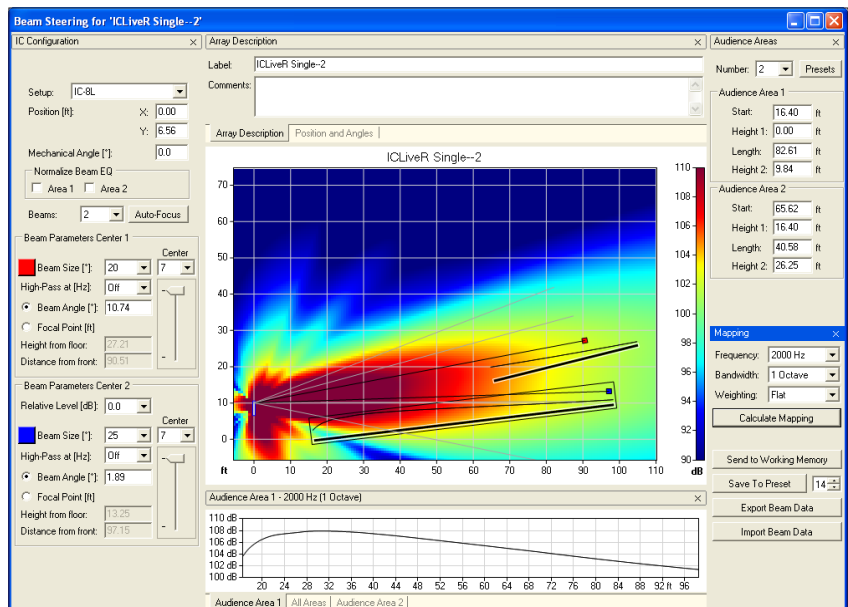

Now that we understand the basics of using beam steering, it's time to investigate another one of the unique tools beam steering includes to make life easier for you. It's called Auto-Focus. You'll find it in the IC Configuration section next to Beams.

Clicking on Auto-Focus will open the setup window shown to the right. Notice that only the Optimize Number of Beams is checked and that except for the Optimize Gain of Beams the other selections are not available. Approve the use of Auto-Focus by clicking on OK and the program will analyze your project and suggest the number of beams, their opening angles, the proper location for their acoustic center (s) and their aiming.

One word of caution, Auto-Focus can only be as accurate as your model so make sure your model is correct.

If you had also checked Optimize Gain of Beams, Auto Focus would have also optimized the gain of each beam to smooth out the coverage. .

You do not need to accept the programs suggestions. If you don't, make whatever changes you feel should be made and return to Auto-Focus.

Notice that now the Keep existing number of Beams and Max Coherence functions are available giving you the opportunity to recalculate based on Max Coherence or on the criteria you defined (User Defined).

Try it out. Auto Focus can save you time and you need to be familiar with it.

Auto-Focus will also let you know if the location you have chosen for the steerable array isn't ideal. You can override this warning if you want and the program will still attempt to properly focus all the beams. You may, however, want to try moving the array up or down to see if you can find a better location for the array or use more or fewer beams to see if you can eliminate this warning prompt.

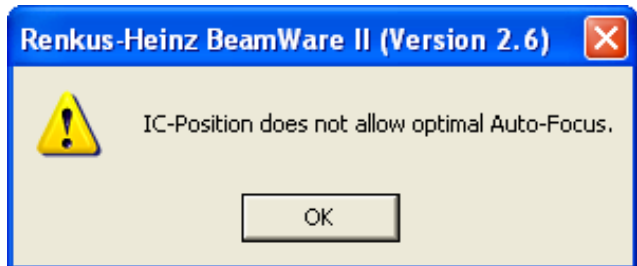
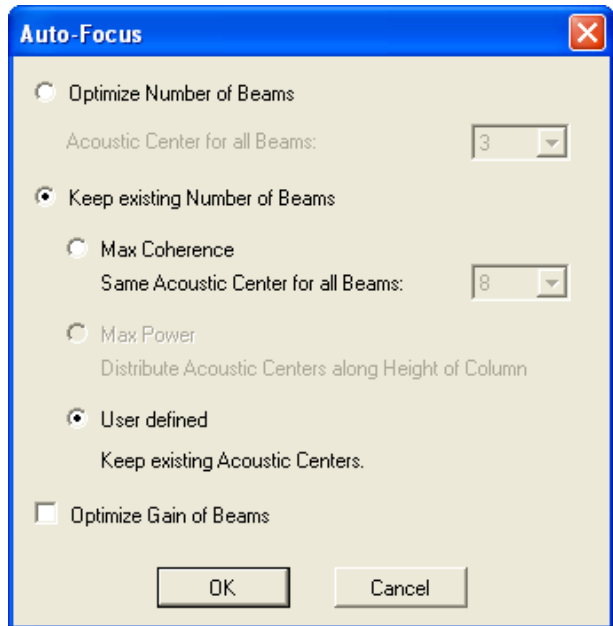
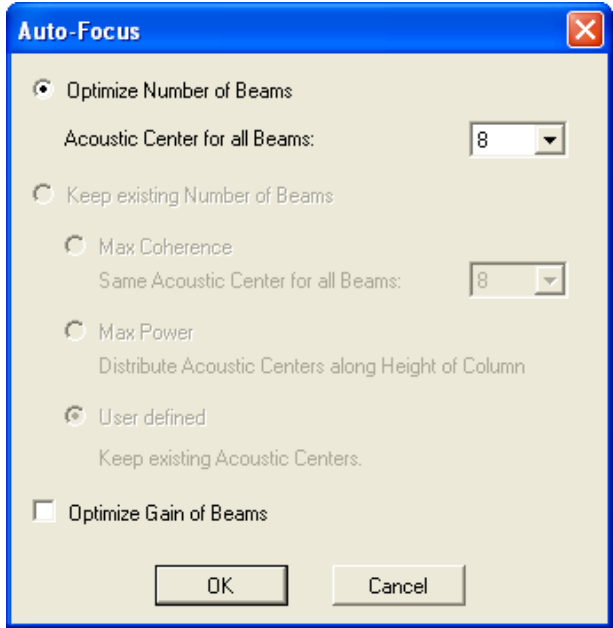

The graphic below shows a 90 foot deep room with a single IC Live array, a typical starting point for a beamware project in a room of this size.. Note that the single beam opening is set at 20 degrees and the acoustic center placed at 7.

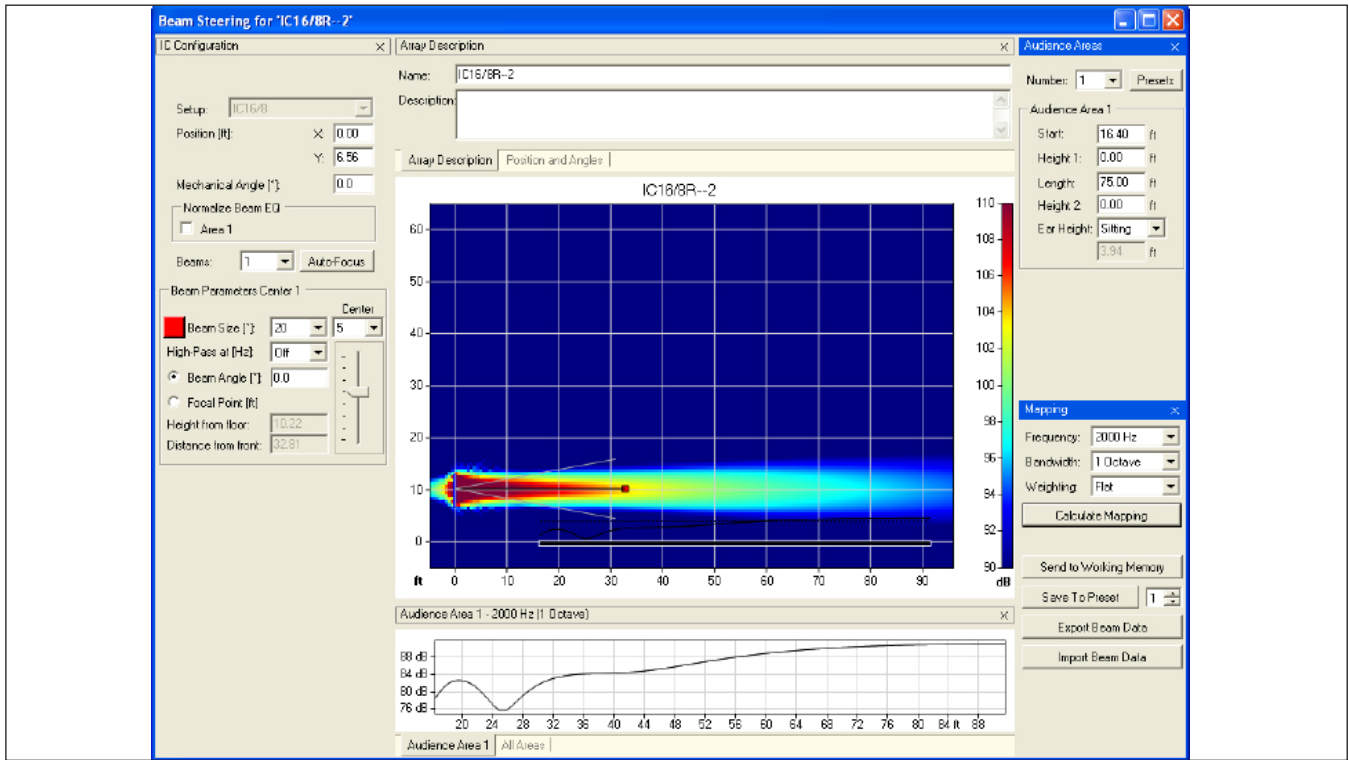

The next graphic is of the same room after Auto-Focus has been applied. Note that Auto-Focus is suggesting 2 beams.

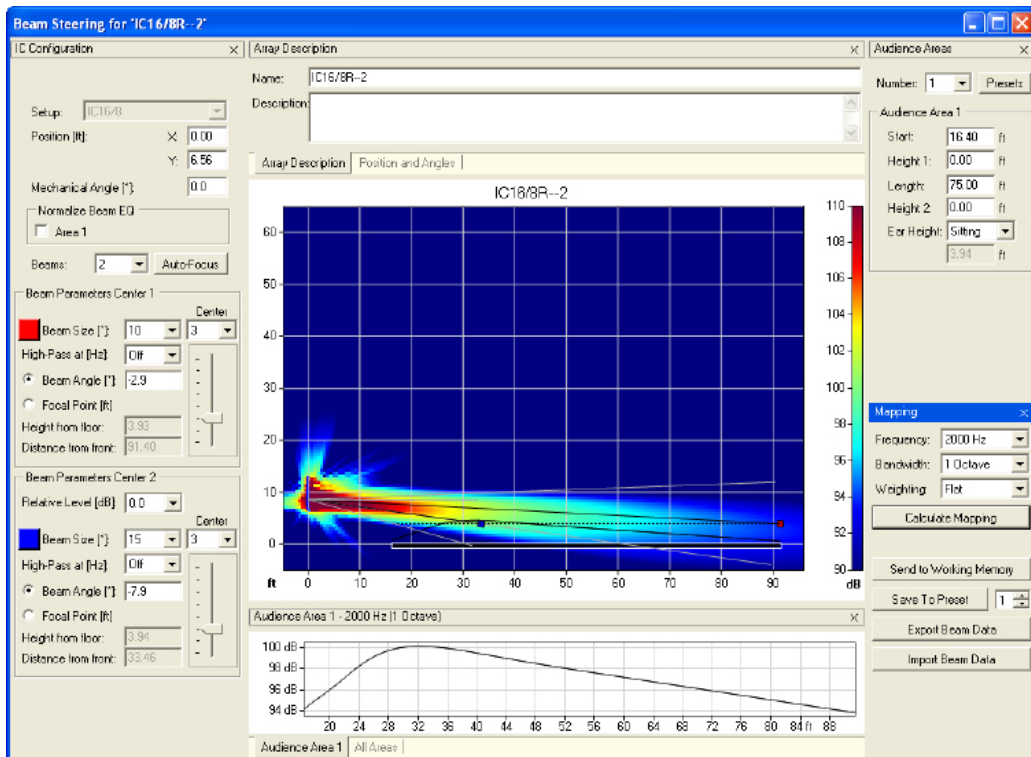

Same setup as the one shown on the previous page only in a larger room.

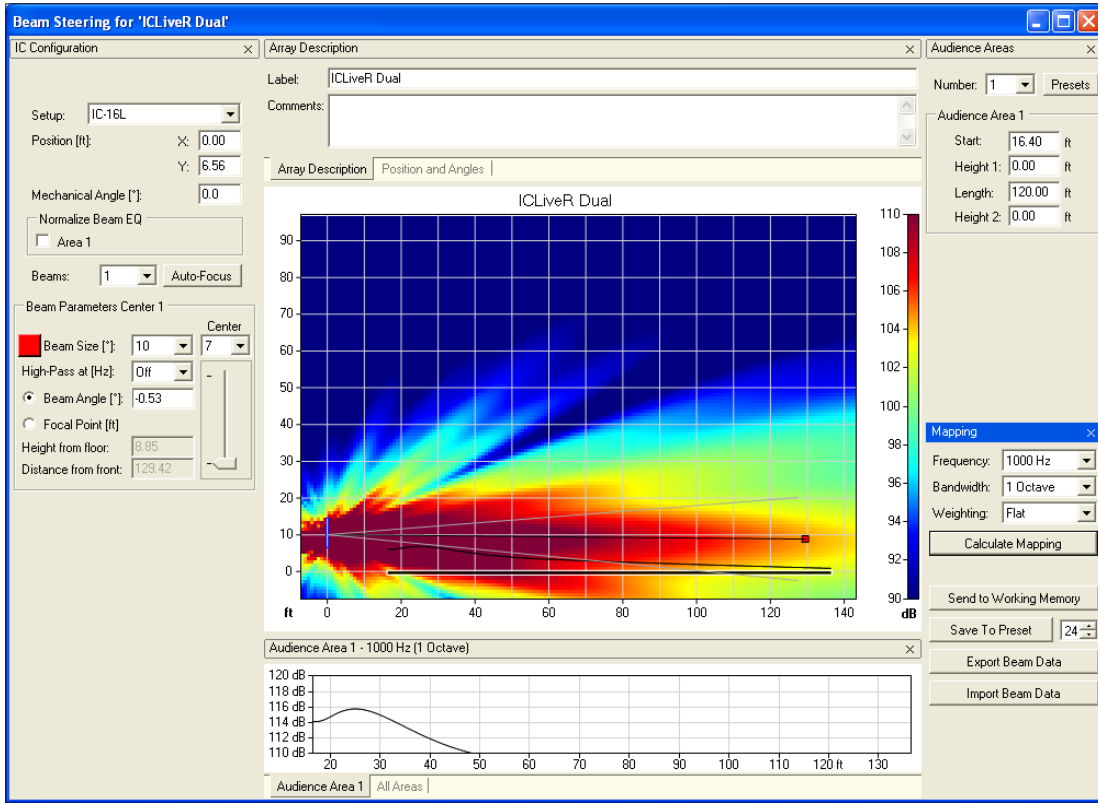

At this point the beam steering changes have not been sent to an associated array or stored as a Preset.

ICL-R arrays can store up to 10 different configurations as Presets in their DSP memory, but beam steering data and other configuration settings can not be saved as a preset in the Virtual mode. The configuration settings can be saved in the project file, but they can not loaded into an array until one is connected.

When an array is connected selecting either Write to Device or Save as Preset in the Beam Steering window will allow you to send the beam steering information to the array. The two commands are in the lower right of the beam steering window. Write to Device will send the beam steering settings direct to the array's DSP and write over any previous settings. Save to Preset will store the beam settings in the designated Preset.

If you attempt to leave Beam Steering without saving the setup information, a prompt will remind you that you need to save the settings if you want to keep them.

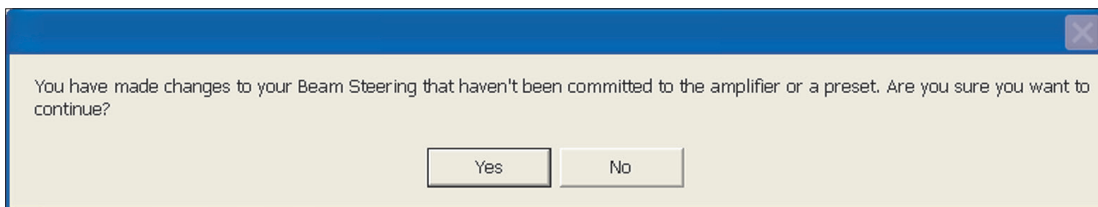

Note that the Beam Steering module controls only beam steering. EQ, compression, etc. configuration settings are controlled in the Control Mode.

### All Loudspeakers, Group and Array Controls

Nw it's time to turn our attention to the All Loudspeakers icon in the upper left of the work space and to the Array and Group features of RHAON.

All Loudspeakers controls all the loudspeakers in the system while Group controls only those loudspeakers included in the Group. Both make it easier to set up run and monitor multi-loudspeaker systems.

Array controls all the array modules included in a vertical line Array. It provides a means of operating "all master" systems.

All Loudspeakers allows you to Mute all the arrays simultaneously or to turn them all On or Off with the push of a single button. You can also assign Input connections, EQ, delay and compression settings for all the loudspeakers in the system at one time or adjust their sound level with just one control.

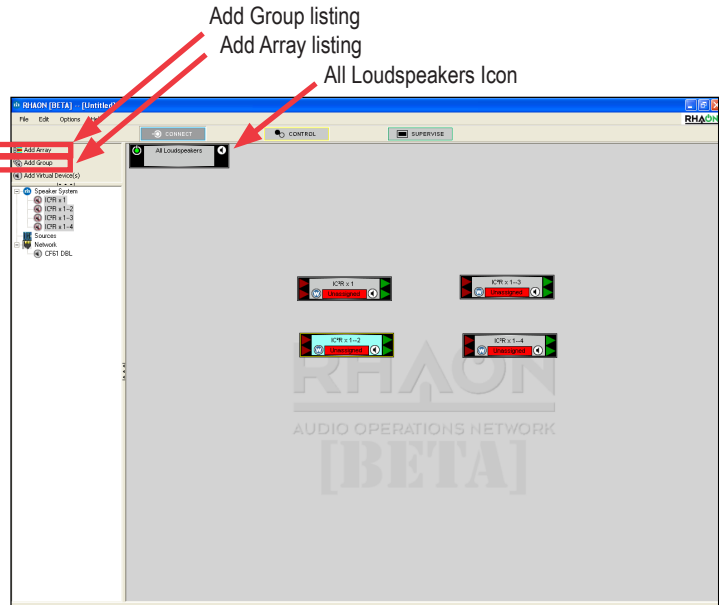

### Group Control

Group Control functions in the same manner only it exerts control only over the devices you choose to include in the Group. You can also break your system into several groups making it even easier to control and monitor larger, more complex systems.

To add a Group, select Add Group in the directory tree section of the workspace. to add a Group folder to the directory tree and a Group icon to the work space. Then drag the Arrays you want included in the Group from their listing in the directory tree into the Group directory tree folder.

Notice that as you add loudspeakers to the Group their icons disappear from the work space into the Group icon. To view all the loudspeaker icons within the group, click on the Expand/ Collapse toggle in the lower right corner of the Group icon. The icons for the arrays included in the Group are linked to the Group icon and cannot be individually moved around the work

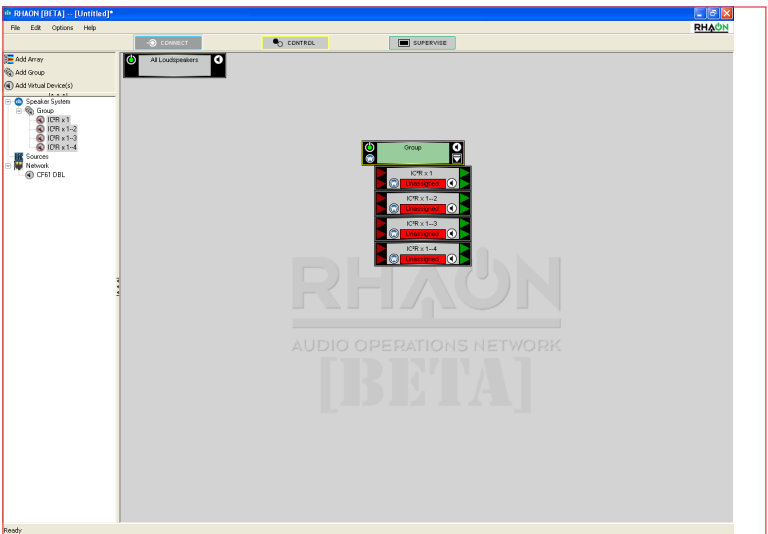

### Array Control

Array Control is intended for use only with IC-R-II array modules and other similar digitally steerable array modules set up for master-to-master operation. It provides a means of controlling these arrays just as Group Control controls all loudspeakers within the group.

An Array folder when created will accept only like Iconyx IC-R arrays, IC Live and IC<sup>2</sup> array modules. It will reject CF, SG, PN, SR and Varia Loudspeakers and subwoofers. It also will not allow you to mix IC-R, IC Live and IC<sup>2</sup> array modules in the same array and limits the size of the array to the same number of modules allowed in master-to-slave operation.

Array Control functions in much the same manner as Group Control only it is limited to (array modules mentioned in the previous paragraph.. To add an Array, select Add Array to add an Array folder to the directory tree and an Array icon to the work space. Then drag the array modules you want included in the Array from their listing in the directory tree into the Array folder.

Notice that when you select the icon for one of the array modules, it opens in the Supervisory mode to make it easier for you to check out the individual modules. You will also find that in the individual modules Connect and Control modes only the Wink and Mute features are active. Control of all other functions has been turned over to Array Control.

Double clicking on the Group icon will open the Connect Properties folder. Notice that the Group Connect window shown here is very similar to the one for individual loudspeakers except for the lack of level meters and CobraNet channel selection facilities.

In the dark grey pane on the left are Power, Wink with Light and Wink with Audio buttons. These tools are similar to those in a Loudspeaker Properties window, but of course they “Wink” the front grille lights of all the loudspeakers in the Group, or send an audio signal (sine wave signal or pink noise) to all of them.

The Power button puts all amplifiers in the Group in Standby or turns all of them On. The Input Volume control and Mute button also affect all amplifiers in the Group. Group metering is not available.

The Input selection radio buttons in the light grey area operate in the same way these controls operate for individual loudspeakers, but control all loudspeakers in the Group.

A Group Control mode window is identical to the one used for individual loudspeakers except for the lack of level meters and the addition of a row of Group Assign boxes under the EQ filters.

When the Group Assign boxes are checked, Group EQ and dynamics settings override individual loudspeaker settings – that is, the settings you define in the Group window will be uploaded to all loudspeakers in the Group. Any EQ filters you do not assign to Group control will be available within each individual loudspeaker’s properties folder.

Whenever you assign an EQ filter or the Compressor to Group-level control, a Warning prompt pops up to remind you that you will be overwriting individual loudspeaker settings.

These controls will be “grayed out” in the individual loudspeaker Properties windows to show that they are under Group control and unavailable.

All Loudspeakers functions in the same fashion as Group control, except it includes all of the loudspeakers on the network in the Group.

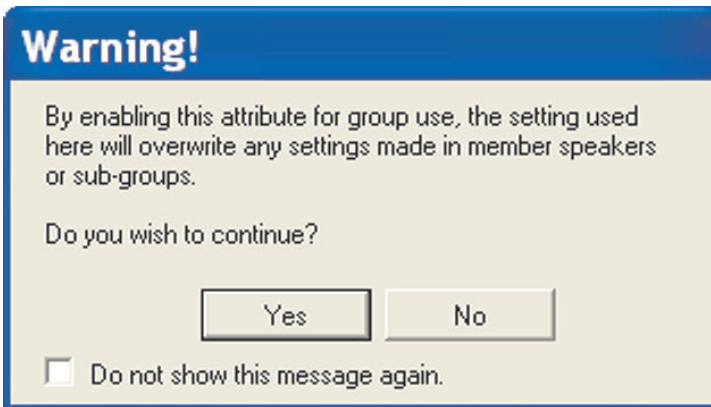
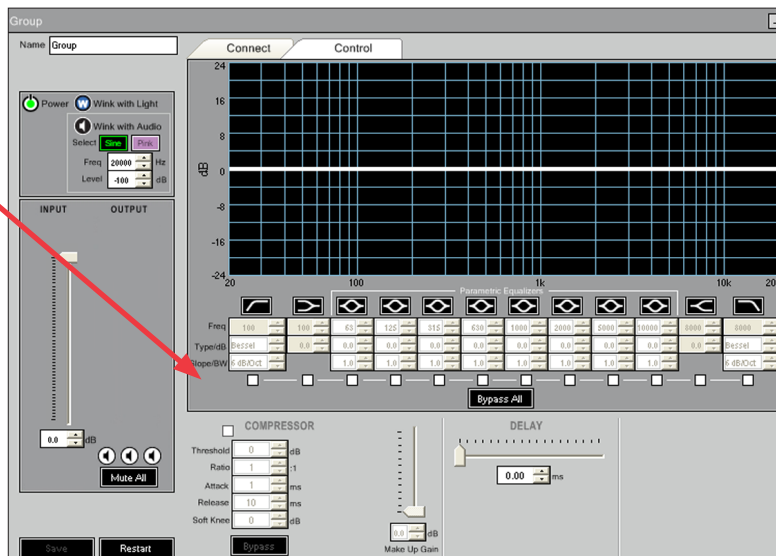
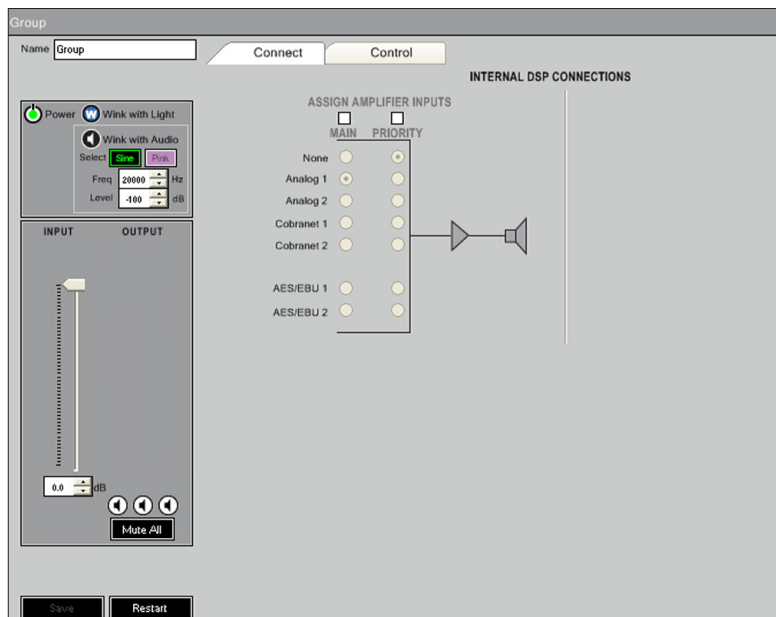

### Copy Settings / Copy Presets

Copy Settings / Copy Presets is a useful RHAON feature that can save you significant time on many projects.

Right clicking on any of the Array Icons while in either the Connect or Control mode introduces a pop up menu that includes a Copy Settings command line. Selecting Copy Settings copies all that array's DSP settings, including Presets and allows you to copy these settings to another array by selecting its Icon and using Paste Settings.

Right clicking on another loudspeaker and pressing Paste Settings introduces the window shown below, which allows you to select what Settings and Presets you want to Paste (copy) into that array.

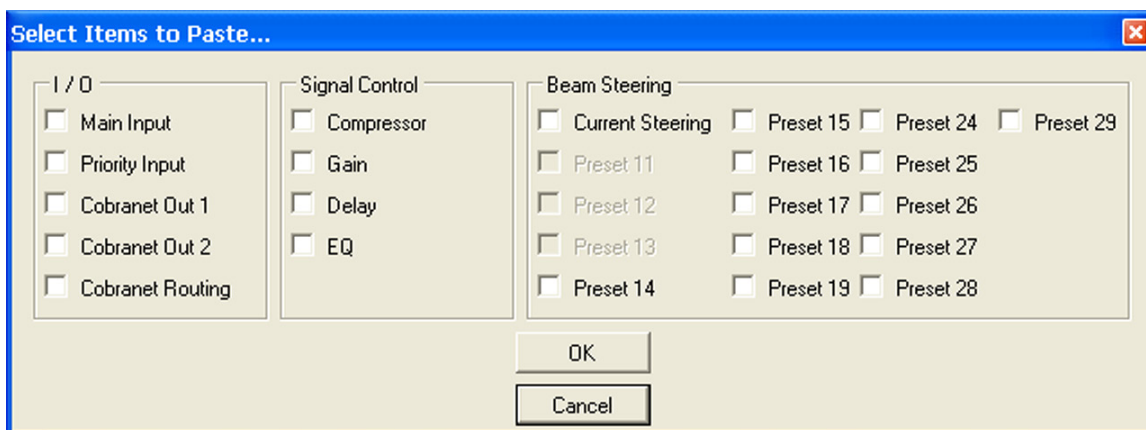
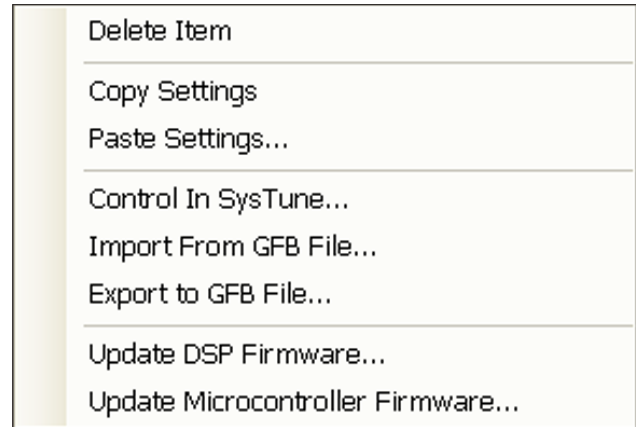

Note that Copy Presets functions on Presets and Beam Steering only between network connected arrays; it operates only on DSP settings in the virtual mode. It also functions only between like units. You cannot, for example, copy Presets or beam steering information from an IC8-R to an IC32-R or from an IC8-R to an ICLive ICL-R. If you try, a warning prompt will alert you to the oversight.

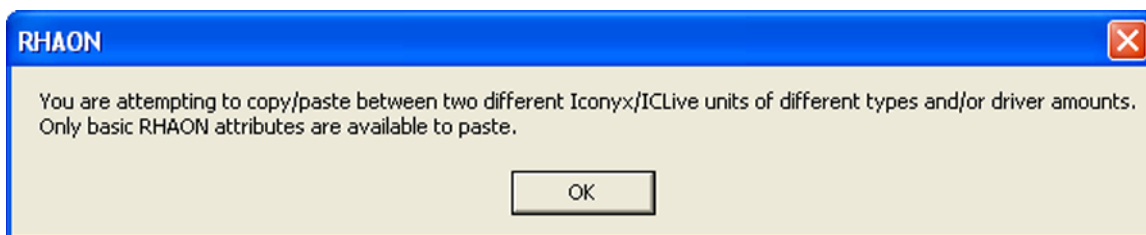

### Reset

Reset is a RHAON feature that allows you to restore an array's DSP and beam steering settings to their original default settings, quickly and easily. Reset can be initiated from either the controls on the rear of the array or from the associated computer.

On the array's rear control panel simultaneously pressing the Volume Up and Pad buttons for several seconds initiates Reset even when the panel controls have been locked. It provides a means of gaining control of the array when a RHAON equipped computer isn't available.

In RHAON on your computer pressing the Reset button in the RHAON Beam Steering window or pressing Ctrl + Load Preset while in either the array's Connect or Control Properties window also enables the Reset feature. A prompt will ask if you want to restore the array's default settings. Answering Yes will initiate the change and restore all the default setting. It's a good way to return to "ground zero" if the array starts behaving strangely.

### Supervise Mode

RHAON's Supervise mode is the one you will use most while your system is in operation (i.e., making sound). It is designed to empower system operators with a comprehensive set of monitoring and loudspeaker/amplifier management tools. In Supervise mode, you can quickly detect a problem anywhere in the system and (if you have access to the appropriate Control mode functions) take corrective action. To switch from Control Mode to Supervise Mode, click on the Supervise tab in either the main workspace, or in a Group or Loudspeaker Properties window.

The main Supervise screen is similar to the Connect screen. It shows your system layout in icon form. The Status field at the bottom of each icon allows you to monitor all Loudspeakers or Groups at a glance. This field will change color and display a text message that indicates the status of the loudspeaker. If there is a problem with any loudspeaker in a Group, that Group's icon will change color and display a text alert.

In Supervise Mode, each Status Indicator will display one of the following colors and messages:

COLOR	MESSAGE	STATUS
GREEN	OK	This loudspeaker is (or all loudspeakers in this Group are) connected and operating
YELLOW	Overload	Amplifier is being over driven
RED	Unassigned	Virtual loudspeaker has not been assigned to a physical loudspeaker
RED	Offline	Loudspeaker has lost power or been disconnected from the network
RED	Driver Open	One of the loudspeaker's drivers has failed
RED	Hot	An amplifier's over temperature circuitry is engaged
RED	Limiting	An amplifier is being over driven or is malfunctioning
RED	Amp Fail	An amplifier has failed

If a Group icon displays an alert (yellow or red bar with text), double-click it to Expand it and show all of its Loudspeaker icons. One of more of these icons will display the same alert: double-click it to open that loudspeaker's Properties window in Supervise mode See below.

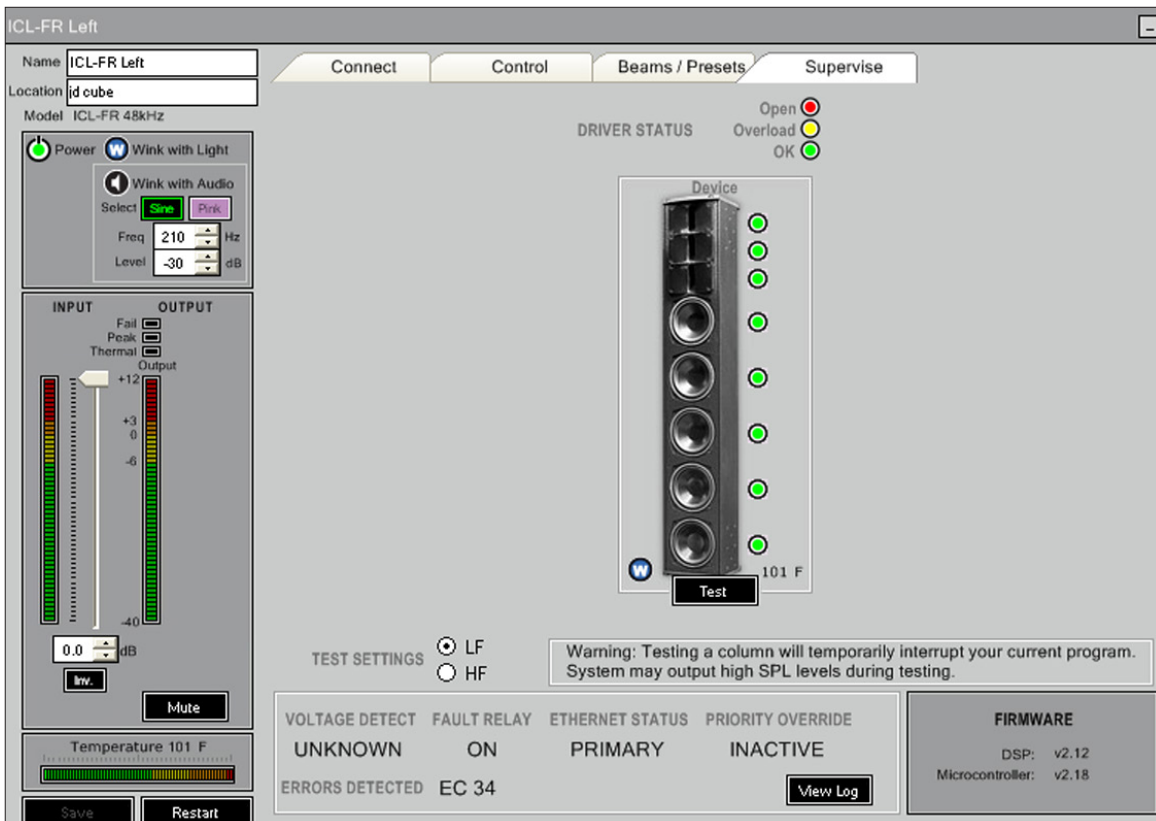

The dark grey pane on the left is identical to the pane in Control Mode. It includes the loudspeaker's input and output monitoring facilities, identification fields, and basic operating controls: Power On/Standby, the Wink Light toggle, Wink with Audio, Input Gain, Polarity Invert, and Mute. Any or all of these controls may be restricted to authorized operators and subject to password-protected access.

The loudspeaker icons on the right each have "traffic light" status indicators; Green for all OK and red for driver failure. Yellow indicates the driver has repeatedly been driven far enough into limiting that its normal life span may have been reduced. The traffic light conditions are mirrored in the status field of the supervise icons. Driver conditions are dynamically supervised with program material but an additional test button can confirm coil status. The use of these manual test buttons is required in case the program material either lacks specific frequencies or is too weak.

Notice that all of the drivers in the array are being monitored and that each module has its own Wink light button. This allow you to easily identify each module and verify that its address number switches are properly set.

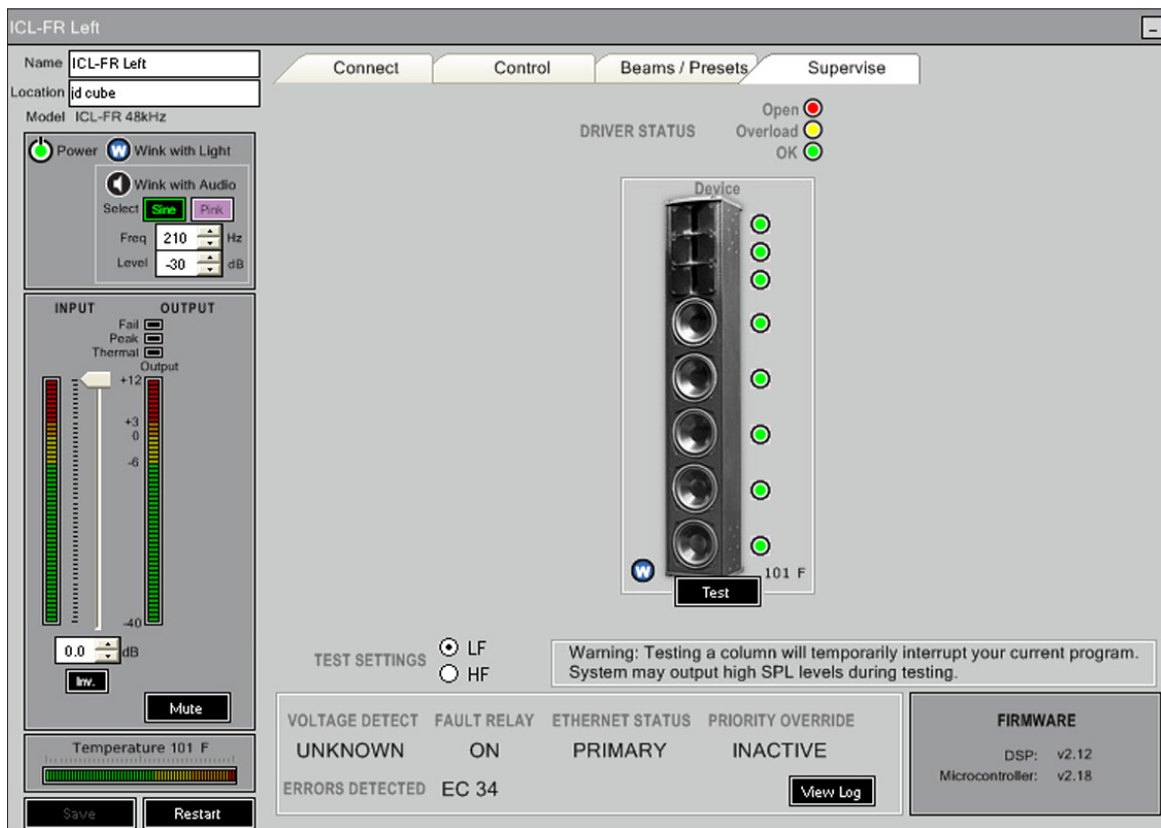

The loudspeaker's RHAON Microcontroller and DSP Firmware version and MAC (Machine Access Control) address are shown in a darker grey panel at the bottom right of this window.

The panel at the bottom shows alerts for Voltage Detect, Fault Relay, Ethernet and Priority Override status.

The Priority Override indicator will change from showing "Inactive" to "Active" when the override circuit is in use (has been activated).

The Fault Relay status line will change from "Off" to "On" when an amplifier fault has been detected or the Ethernet carrier signal is lost.

The Voltage Detect will read "High" when it senses a voltage on the Sense input line and "Unknown" when no voltage is present.

The Ethernet Status will show "Primary" when an Ethernet Carrier signal is detected at the Primary Ethernet input and "Off Line" if the carrier signal is lost, except in "Redundant" systems having a secondary Ethernet source. In these systems, the amplifier will be switched over to the secondary input as soon as the primary signal is lost; the status line will then change to Secondary".

## Event Logging & Notification

RHAON's Event Logging function can record in a .log file events of the types you select. This allows the system's operating status to be reviewed at any time. Audio evacuation and life safety systems are often required to provide this type of logging.

To activate this feature, go to Options in RHAON's main tool bar and select Preferences; then open the Event Logging folder. Select the event types you want to log using the check boxes next to each type of event.

Click on OK to activate Event Logging. The log file will be written to the computer's hard drive in a RHAON.log file in the Program Files/ Renkus-Heinz directory.

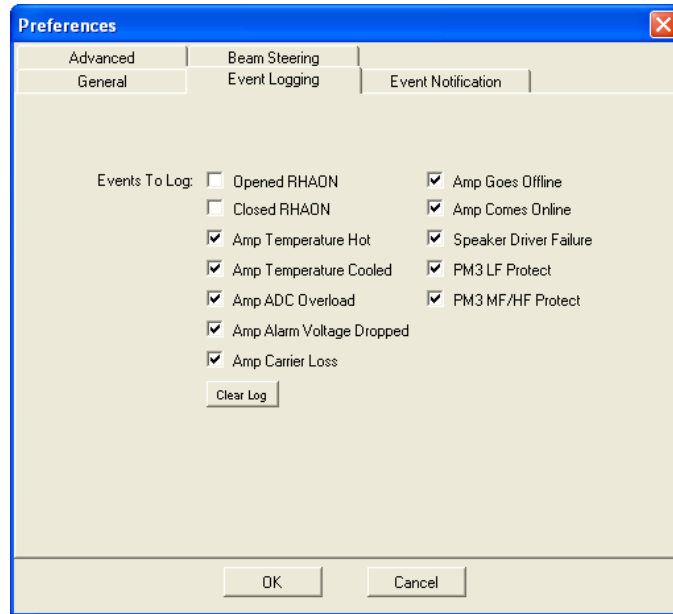

RHAON can also automatically e-mail events to another computer or cellular phone. You configure this function in the Event Notification folder next to Event Logging. As with logging, you can choose the types of events for which you want RHAON to send e-mail notifications.

Because RHAON connects to a NIC (Network Interface Card) with a local IP address, you will need a second NIC in your computer to connect to the Internet. You will also have to specify the SMTP (Simple Mail Transfer Protocol) host and a valid e-mail account in order for RHAON to send e-mail. An IT professional may be able to assist you with these tasks if you need help.

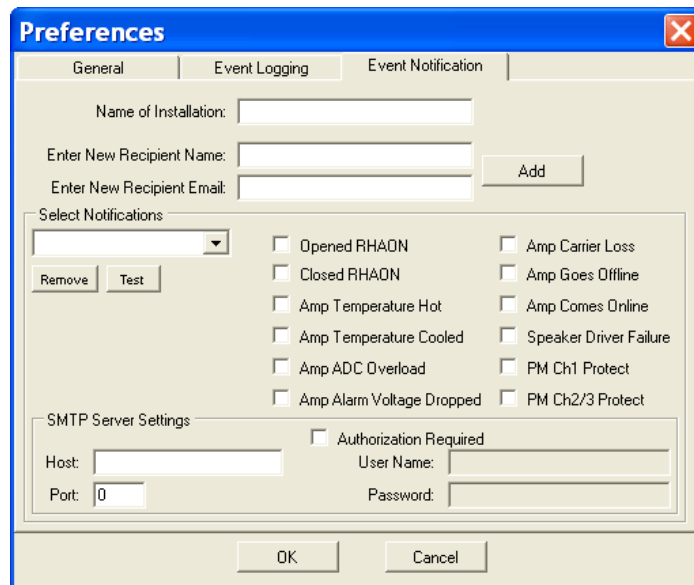

## General Preferences

The Preferences window also allows you to review and change the program's default settings. You will find them under the General tab. We already discussed the Networking Adapter (aka NIC) settings in the Connect section of this manual, so we won't cover them again.

Unit System allows you to change the units of temperature from Metric (Centigrade) to Imperial (Fahrenheit). Under Group Settings, you can set up a Power On Sequencing Delay for all grouped loudspeakers. This will help avoid a voltage surge that can trip building circuit breakers. Depending on the delay interval you select, there will be a .5, 1.0, 1.5 or 2.0 millisecond turn-on delay between each amplifier in the Group.

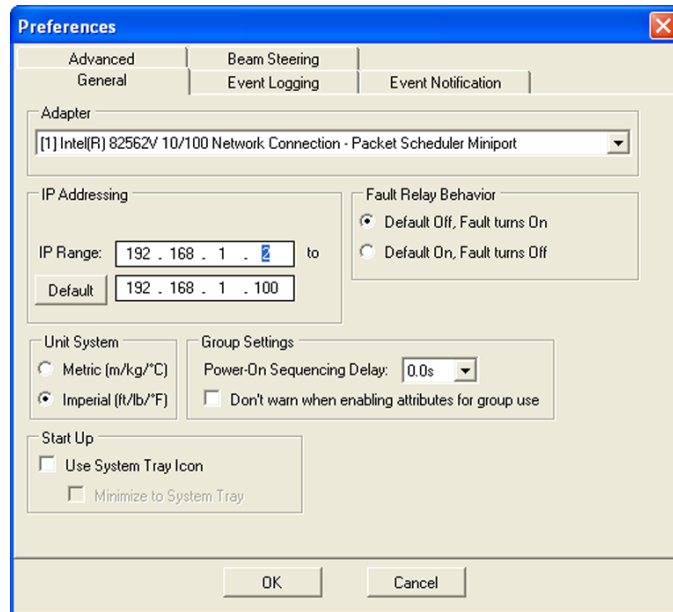

Start Up options allow you to always open RHAON in Full Screen mode and to require Sign-In. When the Sign-In option is checked, the program will ask for your password whenever it is opened.

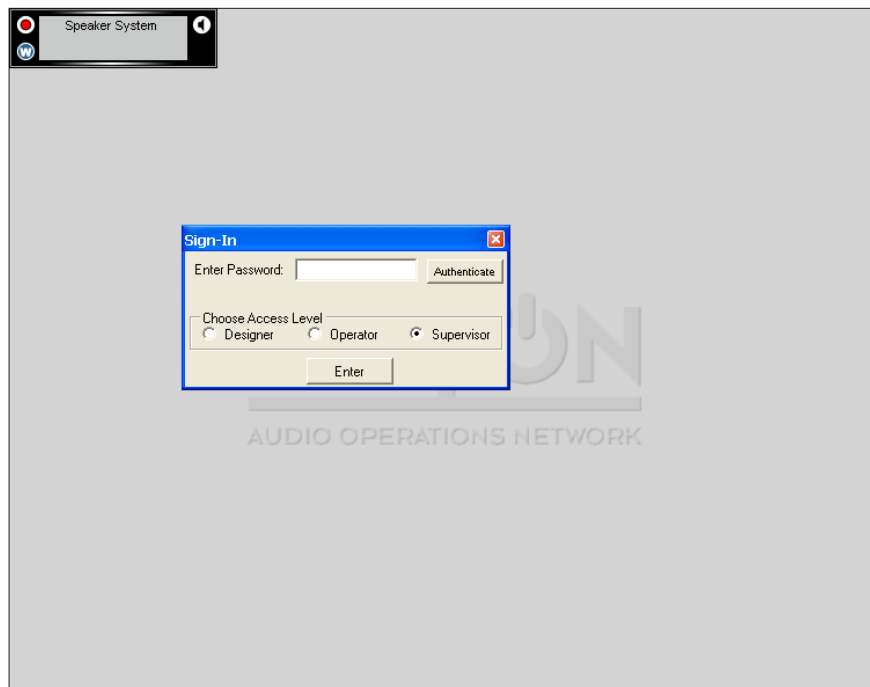

### Password Protection

RHAON software includes three levels of password protection. This features is designed to prevent inadvertent changes of Connect and Control Mode settings by anyone who is unauthorized or unfamiliar with the system.

To open the Password Protection setup window shown below, hit **Control-Alt-p**.

You can set up three levels of control access. They are called Designer, Operator and Supervisor. Each access level should have its own password.

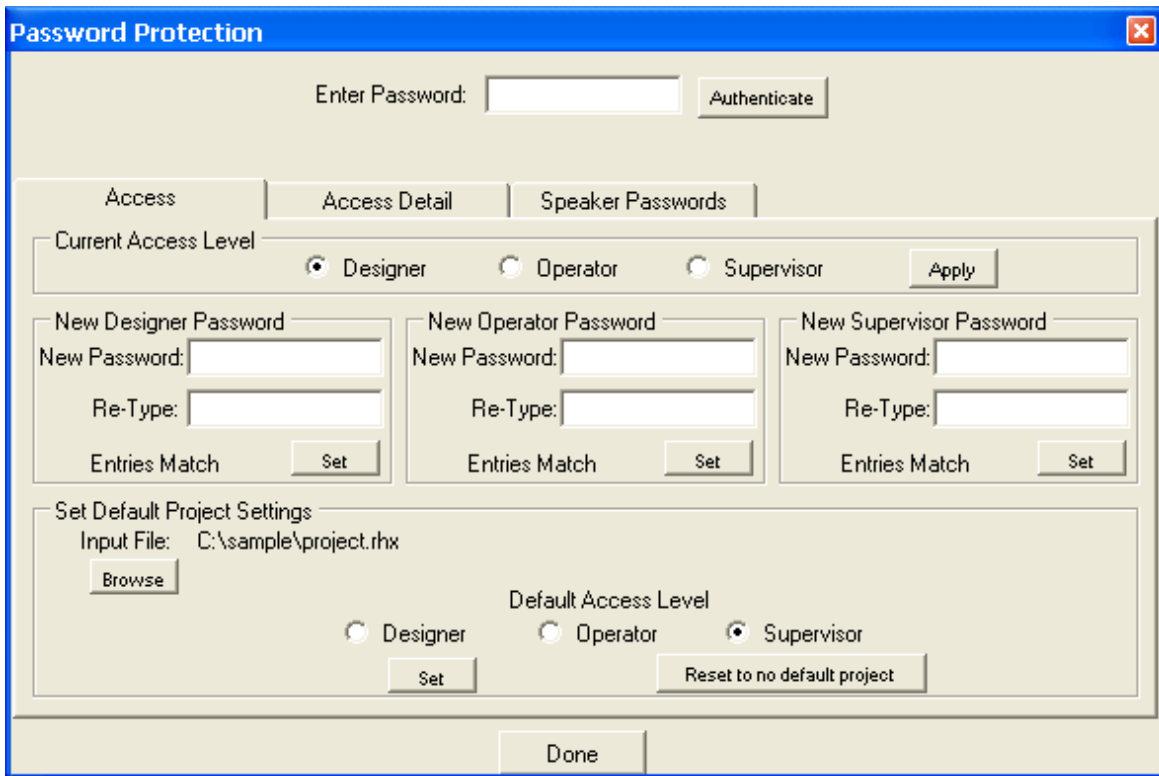

The Designer has the highest level of access. This person should set up the access control system and passwords before turning a RHAON system over to its owners and operators.

The Operator has the next highest level of access. We suggest giving an Operator access to all Control Mode functions that would normally be used while running a show or operating the system. In a fixed installation, Operator level personnel would probably not be granted access to the Compressor, EQ, Delay, Shelving and roll off controls, but they would be able to adjust Input Gain if necessary to respond to clipping and/or over temperature alerts.

The Supervisor access level is intended for those who are only monitoring (supervising) the system for faults and failures. Supervisors would normally be given access to few, if any, of the functions in Control Mode.

RHAON passwords are case sensitive. Once the password access system has been set up it will be impossible to operate RHAON without entering a password. The Password Prompt shown below will appear each time the program is opened and a proper password must be entered before proceeding.

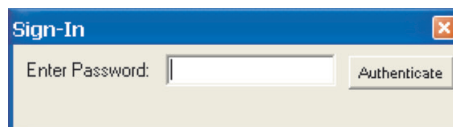

Clicking on the Access Detail tab opens the window shown below. Its settings determine what control features will be available to “Operators” and “Supervisors”. These settings are themselves password protected and can only be changed by a Designer.

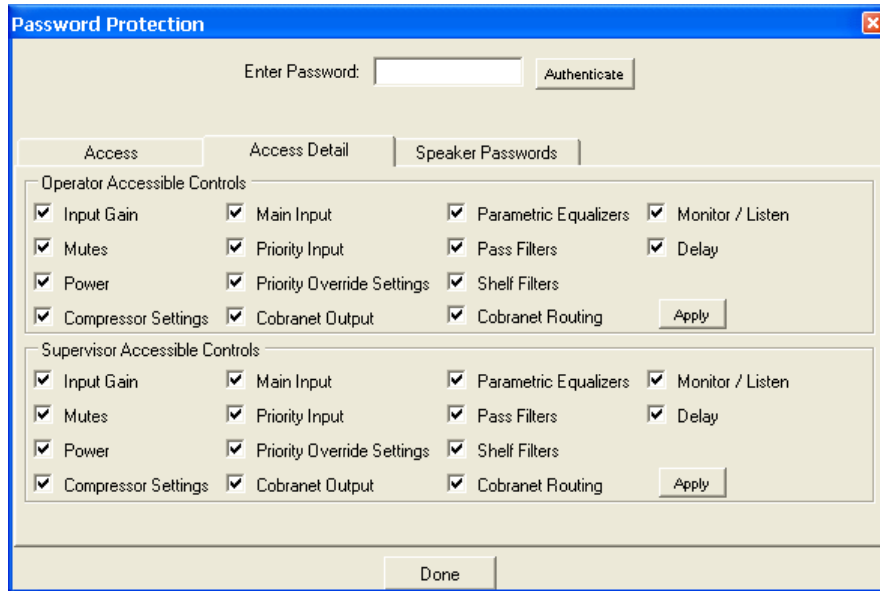

The Password restrictions are stored on the computer used to setup the password protection (usually the “House” computer ) and don't prevent you or someone else from connecting to the network with a RHAON equipped PC and changing the settings.

The Speaker Protection window provides an additional level of protection, as it allows locking the settings for individual loudspeakers to positively prevent their being changed by anyone who doesn't know the password. It locks the settings in the array to prevent anyone who doesn't know the passwords from changing the settings

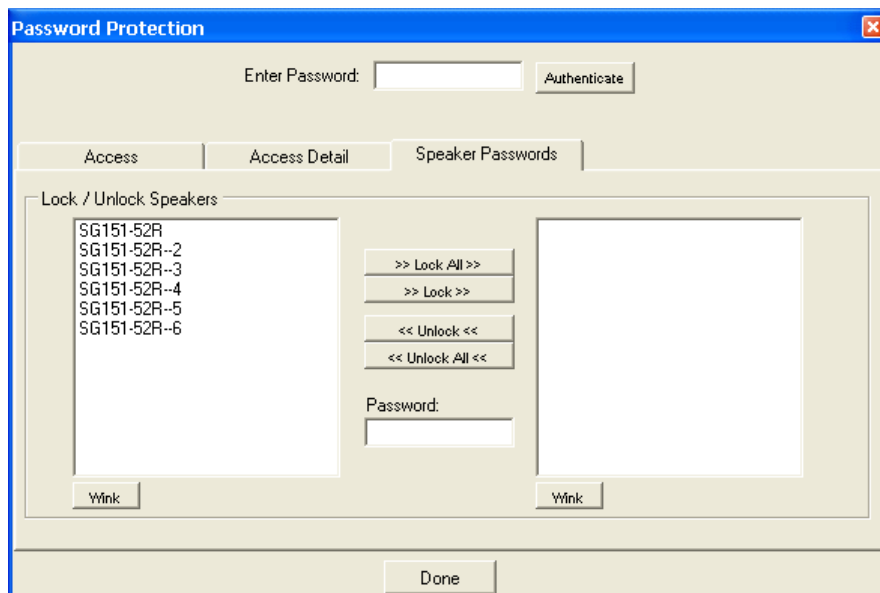

## KEEPING YOUR RHAON PROGRAM UP-TO-DATE

### Updating Your Current Installation of RHAON

New program versions of RHAON are posted on the Renkus-Heinz website, [www.renkus-heinz.com](http://www.renkus-heinz.com), as soon as they are created. We recommend updating to the latest version only if the newer version has features that you need, such as an expanded listing of Renkus-Heinz loudspeakers. In other words, follow the “if it isn’t broke, don’t try to fix it” policy.

There are two easy ways to find out what version of RHAON is installed on your computer so you can determine if a later version is available. The first is to simply open RHAON and observe the opening splash screen. The program version number is displayed there as the program is opening.



The second method is to open RHAON and select the Help drop down menu and click on About RHAON. This will bring up a dialog box with the current RHAON information



## APPENDIX IV: KEEPING YOUR RHAON PROGRAM UP-TO-DATE

### Updating Your Current Installation of RHAON (continued)

To update your RHAON program go to [www.renkus-heinz.com](http://www.renkus-heinz.com) and click on RHAON in the left hand menu to open the link to the REHAON Home page and to the latest RHAON program version; see below.



Select (Download Latest Program Software) from the top of the RHAON page to download the RHAON software program and its Installer from the FTP site (higher version numbers indicate newer releases).

When the FTP site opens notice the prompt that tells you you must open Windows Explorer if you wish to view the site in Windows Explorer. Click on Page to view the drop down menu shown to the right and select "Open FTP Site in Windows Explorer".

The newest program downloads will be found in the Current folder. Open it and select the desired "32-Bit or 64-Bit Setup" download .exe file The prompt shown below will ask what you want to do. Click on Run or Save the file to your computer and then double click on the .exe file to begin the installation routine.

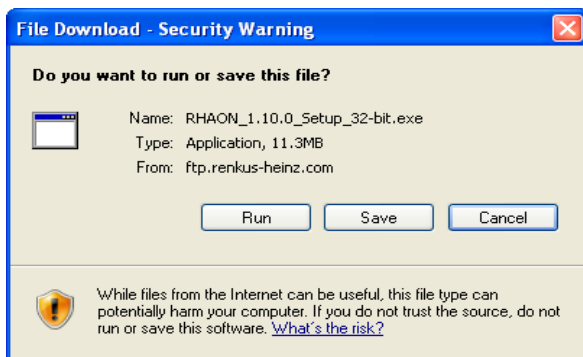
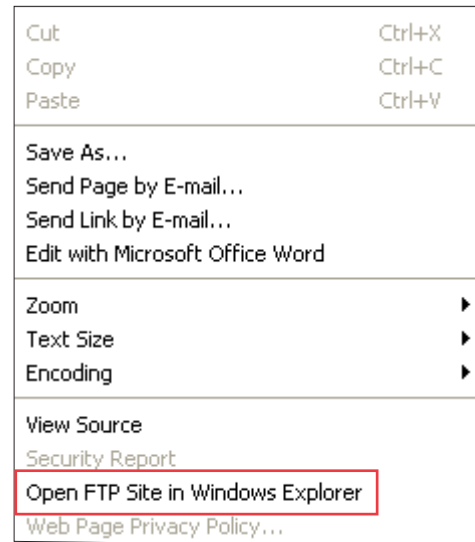

**RHAON 1.10.2 is downwards compatible with earlier versions of RHAON Microcontroller and DSP firmware so you do not need to uninstall a previous version of RHAON before installing program v1.10.2. However, new program features may not function in loudspeakers running earlier versions of firmware. The installation program installs RHAON in a Renkus-Heinz/Rhaon folder on your hard drive and overwrites v1.4 or higher versions of RHAON.**

If you have an earlier version of RHAON on your computer, you do not have to uninstall it. If you want to remove it, you will need to use Start/Control Panel and Add/Remove to uninstall it.

## APPENDIX IV: KEEPING YOUR RHAON PROGRAM UP-TO-DATE

### Updating Microcontroller and DSP Firmware

The latest Microcontroller and DSP firmware files were installed in your loudspeaker before it was shipped to you. They contain the program that runs the DSP microcontroller and the loudspeaker specific control files for the associated loudspeaker. These files are updated from time to time as the firmware is updated and improved. If you are having problems with your system, we may ask you to update the firmware as part of the troubleshooting procedure.

Updating firmware is not as simple a task as updating program software and we recommend you refrain from updating your firmware unless you have a good reason for doing so and you have discussed the process with our technical staff.

If you do need to update your firmware, RHAON make it easy for you to do so. Selecting Check for Firmware from the RHAON Help pull down menu will connect your computer to the firmware download site, check for new firmware files and download any it finds.

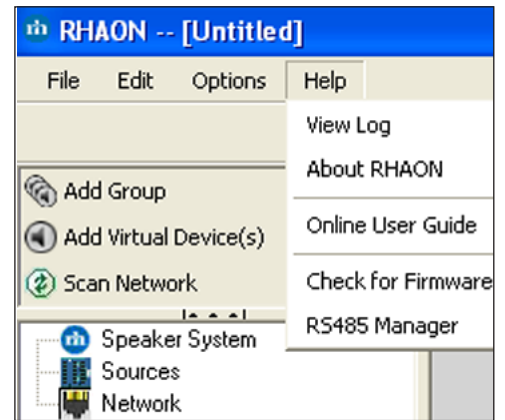

Up-

### Updating Microcontroller Firmware

The latest Microcontroller firmware files (.hex files) were installed in your loudspeaker before it was shipped to you. These files contain the programming that runs the DSP microcontroller in RHAON Empowered amplifiers and are updated from time to time as the firmware is improved.

If you are having problems with your system, we may ask you to update the firmware as part of troubleshooting. Otherwise, don't try to update the firmware unless you have a good reason to do so. To download the latest firmware files go to Check for Firmware under the RHAON Help pull down menu. See page 57.

**Important: When updating earlier versions of Microcontroller and DSP firmware, it is critical that the Microcontroller firmware be installed first.**

**Step 1:** Open RHAON, scan the network and switch to either the Control or Supervise mode. Then right click on the loudspeaker's listing in the directory tree or on the loudspeaker's icon in the main display area to open a pop up menu. The pop up menu will vary depending on which method you choose.

If you choose the loudspeaker's listing under the Network sub directory, the menu shown in figure 1 will pop up. Note that it also includes commands for turning on the loudspeakers Wink light and for sending pink noise to the loudspeaker to help you identify which loudspeaker you have selected.



Figure 1

The menu in Figure 2 will appear if you opened the menu through its listing in the All Loudspeakers section of the directory tree. Notice that it also allows you to set up an interface with SysTune. The interface allows SysTune users to access the loudspeaker's Control Properties window and make final tuning adjustment while observing the results in SysTune. The Import and Export GFB files allow you to exchange data with the EASE SpeakerLab program.

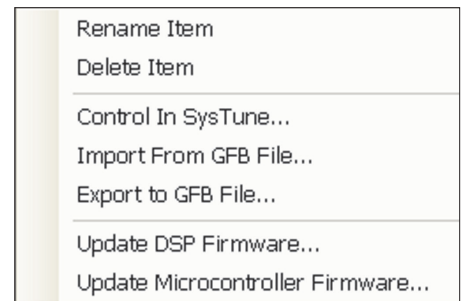

Figure 2

Accessing the pop up menu by right clicking on the Loudspeaker's icon produces the window shown in Figure 3. It is similar to the previous menus, except for not allowing you to Rename the loudspeaker. Be aware that on amplifiers having firmware versions prior to version 1.28 you will need to make sure the Loudspeaker is in the "Power On" mode. Check the Power LED on the back of the amplifier to see if it is lit or if the center of the Power indicator in the RHAON screen is Green. If not, either click the Power button in RHAON or use the Volume Up and Volume Down buttons on the amplifier (press and hold down both buttons at the same time for 3 seconds) to turn the power On.

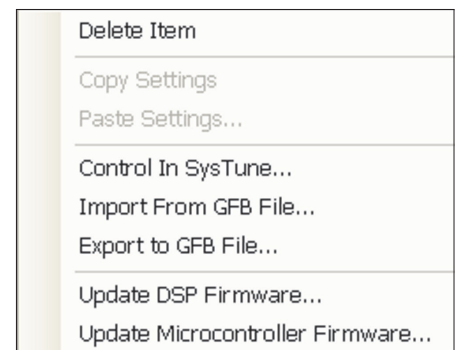
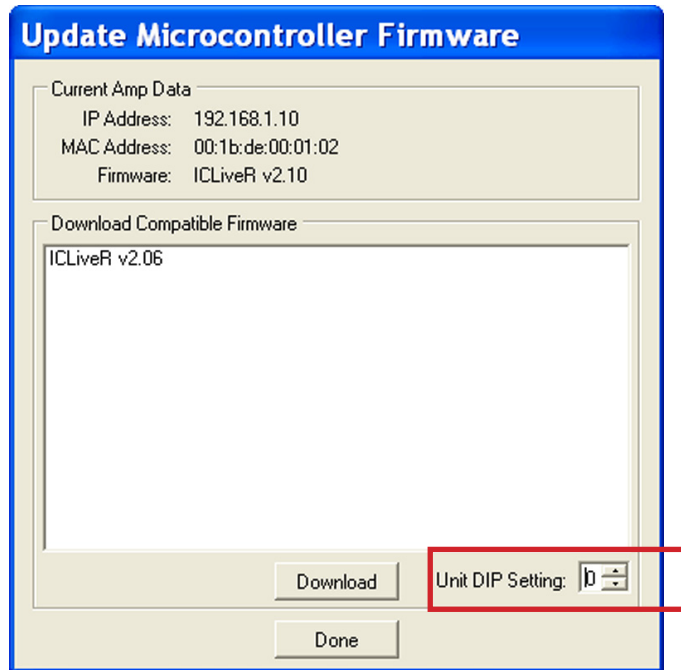

Figure 3

## Updating Microcontroller Firmware (Continued)

**Step 2:** Select Update Microcontroller Firmware and when the window shown below opens select the appropriate firmware file and press Download. Notice that the window tells you what Microcontroller Firmware version is installed in the loudspeaker. Selecting Download will install the new firmware in the loudspeaker.

If you are updating a Stacked (dual) array you will need to separately download the Microcontroller firmware to both the Master (0) module and to the Slave (1) module. Use the Unit DIP Setting arrows to select the correct module.



Step 3: Wait for the Firmware transfer to complete. When finished, control will be returned to the dialog window. Select "Done".

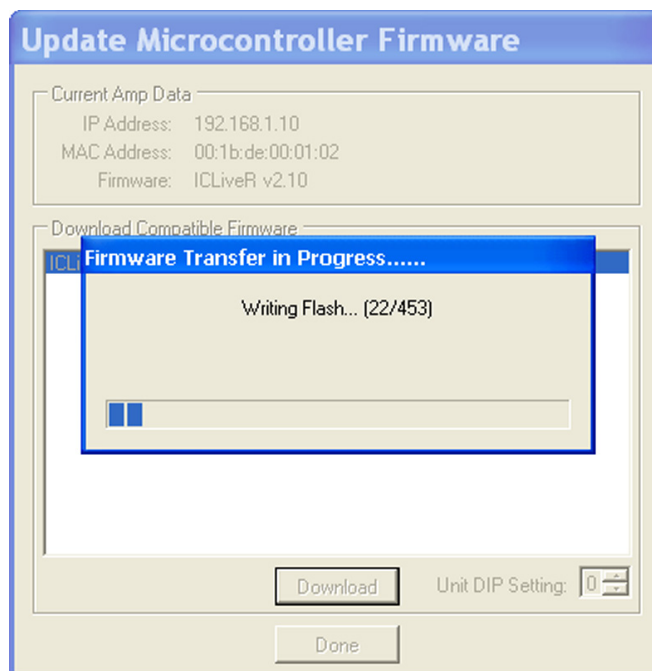

## Updating DSP Firmware

The latest 48 kHz DSP firmware files (.bin files) were installed in your array before it was shipped to you, unless you specifically requested 96 kHz files be installed.. These files contain the loudspeaker specific EQ, crossover and protection settings for the loudspeaker and are updated from time to time as the firmware is improved.

If you system was set up to operate at 48 kHz and you want to run at 96 kHz, you will need to install the 96 kHz .bin files for your loudspeaker(s).

If you are having problems with your system, we may ask you to update the .bin files as part of troubleshooting. To download the latest .bin files, go to Check for Firmware under the Help pull down menu. See page 49. Be aware that .bin files names which start with RH4... are 48 kHz files; 96 kHz files start with RH9...

**Important: When upgrading earlier versions of Microcontroller and DSP firmware to version 1.8.0 it is critical that the Microcontroller firmware be installed first.**

These files need to be placed in the “DSP Firmware” sub folder of your RHAON installation (typically “C:\Renkus- Heinz\ RHAON\ DSP\_ Firmware”).

**Step 1:** In RHAON select either the Control or Supervise mode and then right-click on the one of the loudspeaker listings in the directory tree view or on the loudspeakers icon in the main display area and select “Update DSP Firmware...”. The pop up menus are the same ones we explored on page 51 under Updating Microcontroller Firmware.

Selecting Update DSP Firmware will open the window shown below. Notice that the program lets you know what firmware is installed in the loudspeaker.

**Step 2:** Select the appropriate firmware to download and press “Download”. If no listings appear in the white field, it’s a sign that you have not downloaded any .bin files for that loudspeaker from the web and placed them in the DSP Firmware folder.

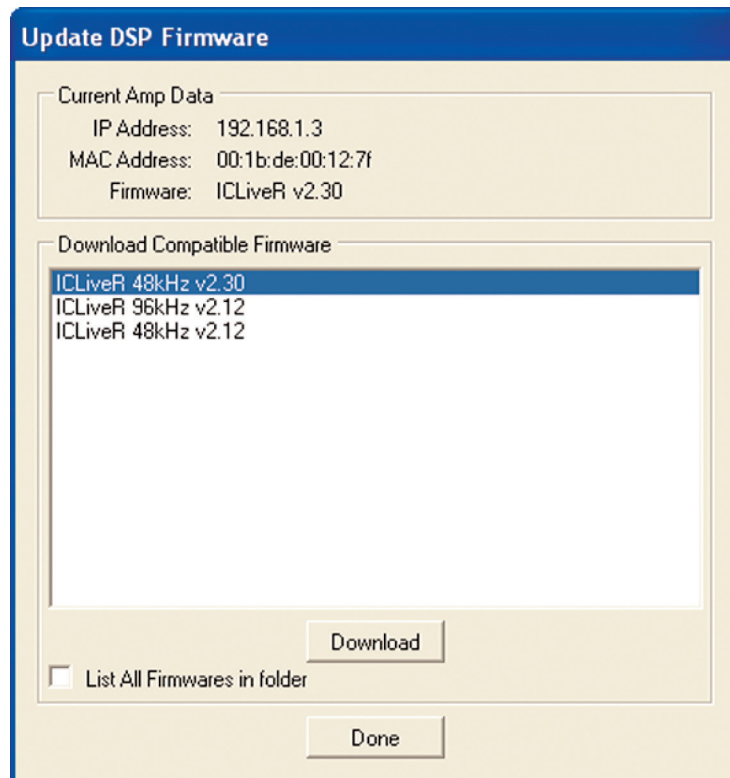

## Updating DSP Firmware (Continued)

**Step 3:** Wait for the Firmware transfer to complete. When finished, control will be returned to the dialog window. Select "Done".

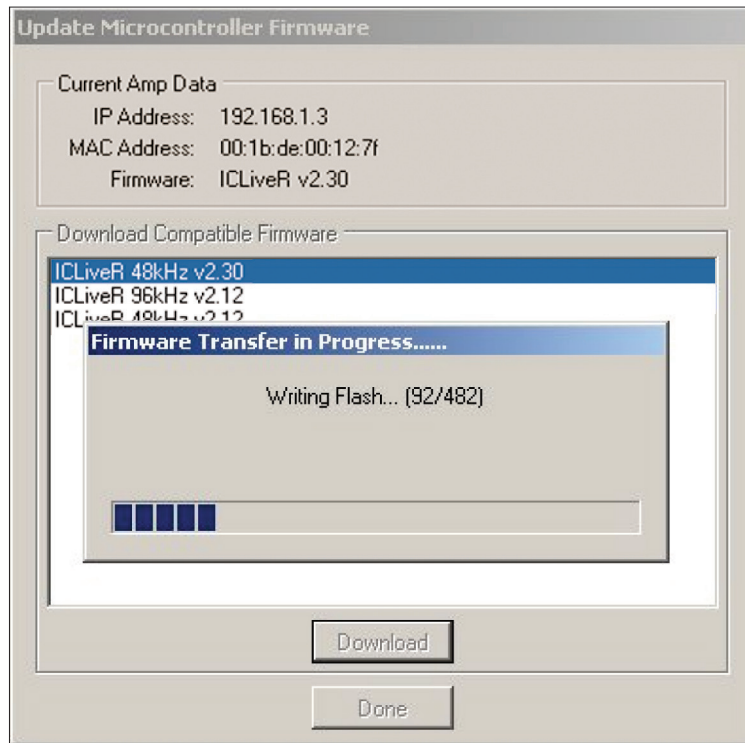

Note: If you are installing the DSP Firmware into a Dual Array (Stacked Array), you need to update both modules. Disconnect the signal cable from its normal connection to the Master (lower) Module and insert it into the Primary Ethernet input on the Slave (upper) Module and reset the Dip Switches on the Slave Module to designate it as a Master (set to 00). Then proceed to update the DSP Firmware just as you did for the lower module.

When the DSP Firmware transfer is complete, select Done. Then disconnect the signal cable from the upper module and reconnect it to the lower module. Finally, reset the upper modules dip switches to Slave (set to 01).

Please be aware that the Mutes and the Analog Input Pad will be On after the update completes and may need to be reset.

## SERVICING and TROUBLE SHOOTING

### GENERAL INFORMATION

Your Iconyx ICL-R steerable column array contains no user-serviceable parts and all service should be referred to qualified service personnel.

Great care was taken in its design, however, to allow it to be serviced in the field without being removed from its mounting position. The transducers can be replaced from the front of the column by removing the grille to expose the transducers and their mounting screws.

The 8-channel digital amplifier/DSP and associated power supply that are the heart of each 8-channel module is one single assembly that can easily be taken out and replaced from the rear.

### TROUBLE SHOOTING HINTS

#### GENERAL

Most Iconyx IC-R and ICL-R / ICL-FR setup and installation problems are “network problems” and not Iconyx or RHAON problems. Your Iconyx array was factory tested before it left our factory and barring shipping damage should be in perfect operating condition.

Nevertheless, it is always a good idea to run a quick check on each module / array before taking it out to the job site and installing it. If you should run into a problem at the site, it's good to know the problem is in the network or the system wiring and not in the loudspeakers.

Preset 10 on single arrays and Preset 20 on dual arrays are set to “Flat” and locked which sends an equal signal to all transducers for use in amplifier and transducer testing. Otherwise, it's difficult to locate defective amplifiers and transducers as the digital beam steering reduces the drive to some transducers making it difficult to determine if a certain channel has failed or is operating satisfactorily. Because the transducers are located so close together using your fingertips to feel cone vibrations is usually a better way to check than listening.

The Analog 1 input is always connected so it's a simple matter to connect a line level analog signal to an array and check out its performance.

### COMMON AUDIO PROBLEMS

#### Hum

The most common sources of system hum are the program source or an improper or poor ground on an audio signal line. Check the program source to make sure the hum isn't originating there. Carefully check all the audio connections to make sure they are properly made.

#### Noise

Most noise problems are the result of improper grounding or of noise being induced into the audio signal line from adjacent noise sources, such as fluorescent lights, and close proximity of the audio signal lines to lines radiating noise. Carefully review all the audio connections and turn off all the lights and any other suspected noise sources.

## SERVICING and TROUBLE SHOOTING (Continued)

### Gated or Chopped Audio

The Analog 1 input is receiving a signal, but some other input has been selected in the RHAON Connect tab. As a trouble shooting aid, the Analog 1 input will always pass audio if the signal exceeds a threshold level even if some other input is selected. The solution is to select Analog 1 as the input or disconnect the analog 1 input signal line.

### Distorted CobraNet Audio

The chances are that this is an Ethernet network wiring problem. See page 59 for details

## NETWORK TROUBLE SHOOTING

A basic understanding of Local Area networks (LANs), Ethernet networks, packet addressing and CobraNet will help you trouble shoot RHAON systems.

### Switched Networks

The Ethernet protocol is a frame-based computer networking technology for local area networks (LANs). This means it is a system for sending uniquely addressed packets of information from a source to a destination, similar to how one sends a letter through the postal service. When you mail a letter to Aunt Gertrude across town, the letter doesn't just go straight from your mailbox to your Aunt's. It goes to the post office, where it is sorted and sent along with Gertrude's local mailman. The same holds true for networks, only replace "post office" with "network switch".

Switched networks are laid out in a "star" configuration, in that the topology has the switch at the center with links fanning out to all devices and/or other stars. Typical transport media are CAT5e cable (up to 100 m) or optical fiber (up to more than 2 km). Communication is handled in a "Point-to-Point" fashion, in that each node communicates solely with the next node attached to it. Using our previous example, the letter starts in your mailbox and is picked up by your mailman, who then transports your letter to the post office, where it is sorted and given to Gertrude's mailman, who then drops it off in her mailbox. How do the switches know where to send the packets? By remembering, of course! Just as the letter to Aunt Gertrude includes a "To" and "From" address, so does a packet. The switch remembers which "From" addresses come from which port in order to speed up future traffic.

### Ethernet Switches

Two of the main distinguishing characteristics between switches are speed and management. The two main speed standards that comprise the majority of RHAON installations are 100Base-T (Fast Ethernet) and 1000Base-T (Gigabit Ethernet). While RHAON device connections are Fast Ethernet, either speed may be used as higher speed switches are backwards compatible with those of lower speeds. The advantage to using Gigabit switches with a RHAON network is that while the individual connections are 100Base-T, the switching times (the time it takes between packet ingress and egress) are much shorter. This becomes especially important from both a hop and total nodes standpoint as the size of a network grows. We recommend Gigabit switches for large networks.

Aside from speed, switches come in two flavors: Managed and Unmanaged. An unmanaged switch is essentially a "dumb" black box that takes packets in and sends them where they need to go. A managed switch, however, allows you much more control. With a managed switch, one can designate subsets of ports as separate networks, control which types of packets are allowed in or out of certain ports, monitor current network traffic conditions, port status, etc. For a great number of installations, an unmanaged switch will suffice. However, for larger or more complex setups, a managed switch becomes critical, though a decent level of networking expertise is required for proper setup.

## SERVICING and TROUBLE SHOOTING (Continued)

### Lesson 2: Packet Addressing

On a Local Area Network (LAN), packets are addressed by the Media Access Control (MAC) address of the network device. MAC addresses are “burnt-in” by the manufacturer of your network device (computer network card, RHAON loudspeaker, etc.) and are globally unique. This is like the VIN on your car. No matter where you register your car, the VIN stays the same and is unlike that for any other vehicle worldwide.

In order to address different devices on different networks, Internet Protocol (IP) addresses were introduced. They allow for easier routing for a vast array of interconnected networks. Similar to this is the license plate on a car. Rather than attempting to search for the car by going through the VINs for every car in the world, one could narrow things down by first selecting the country in which it was registered and then by license plate number within that country. RHAON acts as the license plate authority, if a CobraNet device (RHAON speaker, mixer, etc.) doesn't yet have a “license plate”, it asks RHAON for one and the software kindly obliges.

Packets addressed by MAC address are known as “Ethernet packets”. In addition to information about the source and destination and the payload, there is a marker for what type of Ethernet packet is being sent. IP packets (ones that can be sent within or out of the LAN) have one identifier and CobraNet packets have another. Because CobraNet packets don't contain IP information in their payload, CobraNet is limited to being LAN-only. The structure of an IP packet is very similar, in that it contains - among other information - a source address, a destination address, and protocol type. For RHAON, the protocol types of UDP and TCP are the ones in heavy use. Building upon the UDP protocol is the Simple Network Management Protocol (SNMP), which is what RHAON uses to monitor or manipulate exposed variables (EQ, Bundle Assignments, etc.) on a RHAON loudspeaker or other CobraNet device. At each stage in the process of handling a packet, the previous layer is left behind. Once a payload type is determined, just that payload is handed off to the appropriate handler.

To better understand what takes place when RHAON tells a loudspeaker “Set Gain to -10 dB”, think of Russian nested dolls. Your computer will send out the whole doll, which contains an IP doll, which contains a UDP doll, which contains an SNMP doll, which contains the message “Set Gain to -10 dB”. When a device sends out a piece of CobraNet audio, it sends out a whole doll, which contains a CobraNet doll, which contains the piece of audio.

With CobraNet, since both devices have a ‘burnt-in’ MAC address, communication can happen right away. For SNMP communication between the computer and RHAON loudspeaker to happen, both devices must have a valid IP address. In most home or office networks, there is a device called a ‘router’ that not only contains a network switch, but can also handle the assignment of IP addresses within its network through a protocol called DHCP. CobraNet (and, by extension, RHAON) uses a different protocol for requesting / assigning IP addresses, but the end result is still the same. Your router has a static IP address assigned to it, devices ask it for an IP, and the router obliges. For this same reason you must assign a static IP address to your computer.

### Troubleshooting Tips

Since RHAON relies on standard networking communications and hardware along with CobraNet, general networking and CobraNet troubleshooting documents can also be of assistance in solving problems. Don't throw away any documentation related to the network switches or CobraNet source devices.

You may also want to install and use the CobraNet Discovery program as a supplement to the RHAON Network Manager. CobraNet Discovery is a network management program similar to the RHAON Network Manager, but more extensive. Both are invaluable in identifying and solving network problems.

If you don't have CobraNet Discovery, you can download it at no cost from our ftp site, Go to; <http://ftp.renkus-heinz.com/Software/CNDisco345.exe>. The Discovery program was also included in the RHAON CD you received with your loudspeaker.

## SERVICING and TROUBLE SHOOTING (Continued)

### RHAON Network Manager

To activate the RHAON Network Manager open RHAION and select Network Manager from the File pull down menu.

The Network Manager will scan the Ethernet network, list all the CobranNet devices it found on the network and identify them by name, MAC and IP numbers. It also checks for communication errors (dropped packets). Any errors detected will be counted and listed in the Error column along with a code number identifying the type of error. Notice that the error count continues to increase as the Network Manager continues to scan the network for errors. In the example shown below the ICL-FR Left array obviously has a problem while two other devices are showing an occasional glitch.

Age	MAC ID	IP	Name	Description	Startup IP	Errors	Error Code
750	001bde00080a	192.168.1.5	PN1R-Burn in ra...	RH RHAON 48kHz PN102/LAR v1.40 CobraNet version 2.11.6 CS496112	0.0.0.0	0	--
609	001bde000946	192.168.1.17	4409-2935 Hou...	RH RHAON 48kHz Iconyx v2.12 CobraNet version 2.11.11 CS496112	0.0.0.0	0	--
672	001bde000947	192.168.1.19	4409-2936 Hou...	RH RHAON 48kHz Iconyx v2.06 CobraNet version 2.11.6 CS496112	0.0.0.0	0	--
531	001bde000b12	192.168.1.15	ICL-FR Left	RH RHAON 48kHz ICL-FR v2.34 CobraNet version 2.11.12 CS496112	0.0.0.0	2248...	34
828	001bde000de7	192.168.1.16	CS49611	RH RHAON 48kHz Iconyx v2.12 CobraNet version 2.11.11 CS496112	0.0.0.0	0	--
375	001bde001260	192.168.1.4	CF61 DBL	RH RHAON 96kHz CF81-2R v1.40 CobraNet version 2.11.6 CS496112	0.0.0.0	20	61
141	001ce200052f	192.168.1.21	VoiceBox	Altera Tech VoiceBox 4 I/O CobraNet version 2.11.6 CS496112	0.0.0.0	69	113
219	00602b0402c8	192.168.1.23	Suitcase BOB	Cirrus Logic EV-2/CM-2 [CM18101] CobraNet version 2.11.6 CS496122	0.0.0.0	0	--
453	00602b0402dc	192.168.1.3	Carl's BOB	Cirrus Logic EV-2/CM-2 [CM18101] CobraNet version 2.11.6 CS496122	0.0.0.0	0	--

The Age column shows in milliseconds how long it has been since the device was checked by the Network Manager. It is normal for the numbers to fluctuate rapidly.

The Startup IP column will show the device's Startup IP address, if a startup IP was assigned to it. To assign a startup ID to a single device, double right click on one of the device's listing to open the dialog box show to the right. It allows you to assign a specific IP address (a startup IP) to that device. Startup IP addresses will not be lost in case of a power disruption to the device. You can also assign Startup IP addresses to all the devices at one time by clicking on the Command pull down menu and selecting Reset all IP Addresses as Startup.

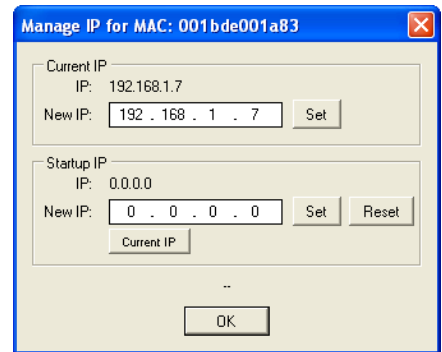

The Error Code Reference Guide is accessed from the RHAON Help pull down menu.

CobraNet Programmer's Reference  
Error Code Reference

---

## 9. Error Code Reference

### 9.1 Legend

**Byte Code** - Numeric error code. Error codes reported through SNMP or HMI are of varying form must be converted to this common byte code representation as per instructions give in section 9.2 below.

**Flash Code** - Code as reported in a fatal fault situation. Flash codes are typically only displayed for fatal errors.

**Type** - Classification and behavior of the error condition.

Table 17. Error Types

Type	Description
TX	Recoverable and expected transmit error

## SERVICING and TROUBLE SHOOTING (Continued)

### Symptom: RHAON reports “No CobraNet Devices found.”

1. Are you trying to use a Wi-Fi connection?

You can't use a Wi-Fi connection with RHAON. Wi-Fi doesn't have sufficient bandwidth to handle Cobranet and RHAON, so you will need to switch to a wired Ethernet connection.

2. Has a private IP address been set up on the computer's Ethernet Network Interface Card (NIC)?

To check:

- a. If you are running Windows 7, Windows 8 or Vista go to Start\Control Panel\All Control Panel Items\Network and Sharing Center\Local Area Connection; click on Properties, then select Internet Protocol Version 4, click on Properties, select “Use the following IP Address” and then enter 192.168.1.1 in the IP address field and 255.255.255.0 in the Subnet mask field. Leave the other fields blank and press OK.

- b. If you are running Windows XP go to Start\Control Panel\Control Panel and Network Connections\LocalArea Connection; click on Properties, then select Internet Protocol (TCP/IP) and click on Properties, select Use the following IP Address”. Insert 192.168.1.1 in the IP address field and 255.255.255.0 in the Subnet mask field. Leave the other fields blank and press OK.

3. Is the correct Network Interface Card (NIC) selected in RHAON? To check:

- a. In RHAON, go to the Options pull down menu, click on Preferences, select the General tab and then select the correct NIC.

(Note, if the computer has more than one NIC, make sure you select the same one you configured in step two above.

- b. Before leaving the General tab, check to make sure RHAON is set to manage the correct IP Range. It should be set to 192.168.1.2 to 192.168.1.100.

(Note: Although other private IP ranges can be used we recommend the 192 168 1 address and suggest you use it unless you have a specific reason not to. Refer back to page 23 for details.

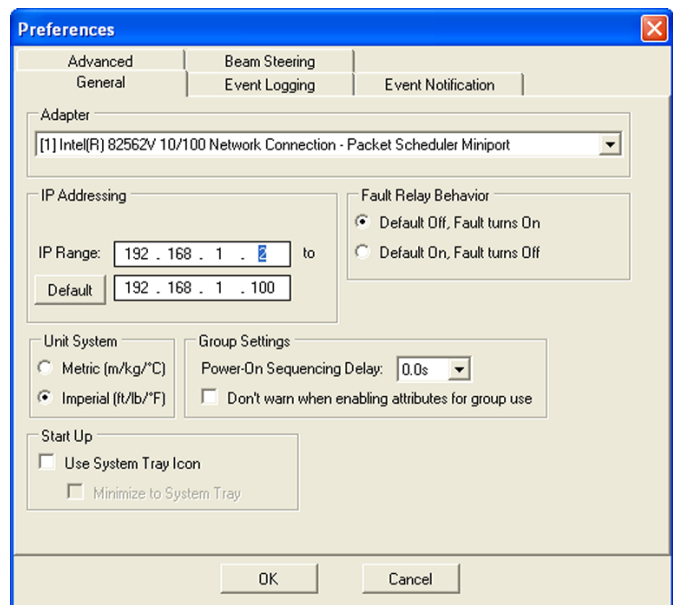
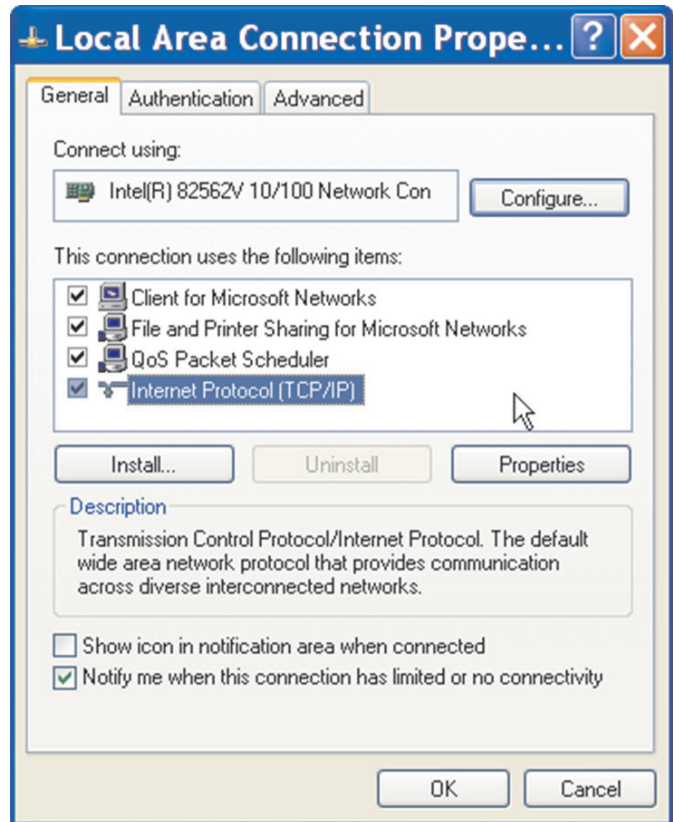



## SERVICING and TROUBLE SHOOTING (Continued)

3. Check for split pairs. A split pair cable will drop packets even if the cable is only 2 meters long. The incorrect wiring example shown below represents a split pair.

### CORRECT WIRING

- Pins 1 & 2 = 1 pair
- Pins 3 & 6 = 1 pair
- Pins 4 & 5 = 1 pair
- Pins 7 & 8 = 1 pair

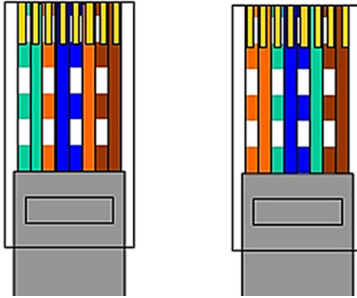

### INCORRECT WIRING (Split Pair)

- Pins 1 & 2 = 1 pair
- Pins 3 & 4 = 1 pair
- Pins 5 & 6 = 1 pair
- Pins 7 & 8 = 1 pair

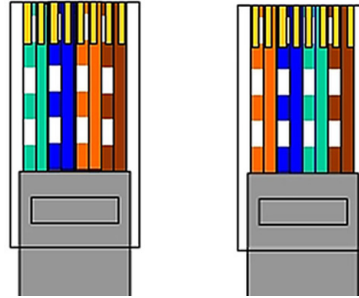

4. Re-make the RJ45 connector. A marginal or corroded crimp will cause dropped packets.

5. Check the cable length. The Ethernet standard for unshielded twisted pair copper cables is a maximum 100 meters (330 feet). Copper cables longer than this will not support CobraNet streaming audio.

### Symptom: I can communicate with my Iconyx array, but I get errors when writing beams.

1. This is a classic symptom of network problems. Go to the Network Manager or start CobraNet Discovery and look at the error count for all devices. Any device that shows errors has a suspect network connection. Review the previous page for troubleshooting tips.

### Symptom: Analog audio sounds like its gating.

1. You are sending a signal to Analog 1, but some other input is selected on the Connect tab. As an aid to troubleshooting the Analog 1 input will always pass audio, but if some other input is selected, Analog 2 for example, the signal to Analog 1 must exceed a threshold, this is why you hear it gating. Select Analog 1 as the input and the gating will stop.

### Symptom: My Iconyx is slowly flashing the blue wink light.

1. You have the Ethernet cable plugged into a slave unit. Either move the cable to the master unit or set the unit with the cable to be the master.

### Symptom: My IC-Live Dual shows up as only a single IC Live module.

1. Is the wink light flashing slowly? If so, you have the Ethernet cable plugged into a slave module. Either move the cable to the master module or reset the DIP switches.

2. Check the DIP switches, there must be only one master and the slaves must be individually identified as slave modules.

3. Did you install the interconnect cables between the two modules? If not, you must do this.

**SERVICING and TROUBLE SHOOTING (Continued)**

4. Has the interconnect ribbon cable been accidentally pinched between the cabinets? If so, it may be damaged and needs to be replaced.

5. Try Restarting the unit by pressing the Restart button. Double click on the the array's icon and press the Restart button when the properties window opens.

**Symptom: Both the green and amber LEDs on one of my device's Ethernet port are flashing; on all other devices only the green LED is flashing.**

1. This indicates that this RHAON device is acting as the CobraNet Conductor and it is passing signal. Every CobraNet network has a "conductor" to which all other devices are synchronized. The flashing amber LED indicates this device is the conductor. This is a normal condition.

**Symptom: Some of my RHAON features are not working even though they worked previously. For example, when I try to change Presets the new Preset won't load and I can change my EQ settings but can't save them to the loudspeaker(s).**

1. This indicates your CobraNet components are not functioning properly and communications between your computer and the loudspeakers on the network have been disrupted, a problem caused by your computer having gone into Sleep mode or by some other Windows event. To correct, close RHAON (and, if running, CobraNet Discovery) and bring up the Windows Task Manager (Ctrl-Alt-Delete). Under the "Processes" tab, look for 'PACNDISCO.EXE' and 'PASSBRIDGE.EXE' (Windows may the names and add '~1'). Select them and click "End Process". Proceed to re-open RHAON and/or CobraNet Discovery.

An alternate method of correcting the problem is to Restart the computer. To prevent this from reoccurring set your laptop's Hibernation / Sleep settings to "Never".

Note that this CobraNet malfunction does not affect normal operation and your system will continue to operate normally until you try to change some of the settings.

**SWITCH RELATED ISSUES**

**Symptom: I placed my RHAON devices on the same network as other devices (venue PCs, lighting, etc.) and now neither RHAON nor the other devices are acting abnormally.**

1. We recommend that your RHAON network be placed on a network separate to that of anything else. If it is absolutely necessary to have them running through the same switch, it is recommended to use a managed switch and set up separate Virtual Local Area Networks (VLANs), grouping the ports you wish to use for RHAON in one VLAN and the ports for other devices in another.

**Symptom: I have set up my VLANs but now I cannot connect to / scan for the RHAON loudspeakers on my network.**

1. Verify that the physical ports both your RHAON loudspeakers and your computer are connected to are all on the same VLAN.

2. Verify that SNMP traffic (UDP ports 161 and 162) and CobraNet traffic (Ethernet protocol identifier 0x8819) are allowed on your VLAN. Consult your switch documentation for how to configure VLANs.

## SERVICING and TROUBLE SHOOTING (Continued)

**Symptom: I have to wait 10-20s for my device to be “connected” and traffic to begin when connecting my loudspeaker to the switch.**

1. Your switch may have Spanning Tree Protocol (STP) turned on. STP prevents accidental looping in your network topology, but unfortunately needs to run an analysis on any new connection before it is deemed OK to be “on”. If you want to avoid the delay and don’t need any services STP provides, turn off STP on your switch. Consult your switch documentation for instructions.

## NOTIFICATION E-MAIL RELATED ISSUES

1. Be aware that a second network interface connected to a separate network is required for e-mail notifications or for using Remote Desktop-type software to control the RHAON computer.

You will need to contact the network administrator at the installation for details on connecting to their Simple Mail Transport Protocol (SMTP) server, also known simply as ‘the outgoing email server.

**Symptom: While attempting to send emails the following Error Message “The specified string is not in the form required for an e-mail address.”**

1. Be aware that what you enter in the “Name of Installation:” field is used as part of a spoofed “From:” field in the notification e=mail. Use of non US-ASCII characters in an e-mail address is invalid. For example, use of Greek letters, symbols not on a US keyboard, or the ‘@’ symbol are not allowed. For more information, please visit: [http://en.wikipedia.org/wiki/e-mail\\_address](http://en.wikipedia.org/wiki/e-mail_address).

**Symptom: I need to change the sample rate of my Array from 48 kHz to 96 kHz. How do I do this?**

1. You need to install new 96 kHz DSP firmware (.Bin files) in your array. Open RHAON, Scan Network, right click on the array’s listing in the directory tree and select Update DSP Firmware from the pop up menu. When the Update DSP Firmware screen opens, select the newest 96 kHz .bin file and press Download. Refer back to page 60 for more detailed instructions on making this change.

**Symptom: I updated the firmware in the array I use for demos and now it doesn’t work. What went wrong and how do I fix it?**

1. Chances are that you installed the DSP Firmware .Bin files before installing the Microcontroller Firmware Hex files. The .Hex files need to be installed first. Re-installing the .Bin files should solve the problem.

**Symptom: I updated the firmware in my ICL-R-DUAL array and now it is acting weird. What could have gone wrong?**

1. Chances are that you updated the firmware only in the Master Module and did not update the slave module. When the firmware is being updated in a multi-module array like the ICL-R-DUAL, the firmware must be individually updated in all modules. Refer back to page 59 for details.

**Symptom: I’m trying to update the firmware in one of my Iconyx installations, but I keep getting error messages while trying to download the .Hex files.**

1. This sounds like a network problem. Use the Network Manager to check for network problems. Refer back to page 67 for trouble shooting tips. If possible, disconnect the array from it’s network connections and connect your laptop directly to the array.

## SERVICING and TROUBLE SHOOTING (Continued)

### AUDIO FAILURE PROBLEMS

**Symptom: One of my Iconyx / IC Live arrays has been working fine, but now it seems to be dead; it isn't passing any audio. What can I do?**

The first thing to do would be to check the network connection.

Use RHAON to scan the network. If you can see the array on the network, drag it into the RHAON work space. If it Sync's the network connection is OK.

1. If you can't see it, check your network setup. Refer back to page 58 for detailed instructions.
2. Check the Array's setup to make sure someone hasn't changed it.

In RHAON double click on the Array's Icon and open the Connect tab.

Is the power turned On? If not, turn it On.

Is the volume turned on all the way? If not, turn it up all the way.

Is the Mute On? If yes, turn it Off.

3. Select Pink Noise and click on Wink With Audio. Do you hear pink noise coming out of the array?

If the answer is yes;

The array appears to be working and you are probably dealing with an intermittent (drop out) problem. Skip ahead to Audio Drop Out.

If the answer is no;

Is the input meter showing activity? If it isn't, either the amplifier is dead or you aren't able to communicate with it.

Is the output meter showing activity?

If the answer is no even though Mute is turned Off, the problem could be in any one of three modules. The Wink With Audio signal is generated within the DSP module and not within the amplifier, so the problem could be in either the DSP module, the Power Supply module or in the Amplifier.

Before calling Renkus-Heinz for assistance;

4. Switch to the Supervisory mode in RHAON and start the Driver test tone. Do you hear the test tone?

If the answer is No, the amplifier is definitely dead.

If the answer is yes, the amplifier is OK and the problem is either in the Power Supply module or the DSP module.

The Driver test tone originates in the amplifier module so if it works the amplifier module is OK.

5. A likely suspect in older arrays is the SRC (Sample Rate Converter) in the DSP module. It is firmware controlled and updating the microcontroller firmware may solve the problem.

## SERVICING and TROUBLE SHOOTING (Continued)

Check the Microcontroller version installed on the array (the version number is shown in the RHAON Supervisory window) and if it is earlier than version 2.43 update to the latest version.

Please call our technical support staff before updating the firmware. They will be glad to walk you through the update process.

If this solves the problem, great! If it doesn't, you will need to return the unit to us for repair or replacement. Call our Customer Service Manager and ask for a return authorization.

## AUDIO DROPOUT

**Symptom: One of my arrays failed and I turned it Off while waiting for a service man to show up. When he arrived it was working fine.**

### **What is happening?**

The likely suspect is the SRC (Sample Rate Converter). It malfunctioned and then restored itself while the power was turned Off.

Intermittent failures like this are hard to predict; the same thing may happen the next time you use the array or it may never happen again.

The SRC is firmware controlled and updating the microcontroller firmware may prevent the problem from reoccurring..

Check the Microcontroller version installed on the array (the version number is shown in the RHAON Supervisory window) and if it is earlier than version 2.43 update to the latest version.

Please call our technical support staff before updating the firmware. They will be glad to walk you through the update process.

ICL-R Dimensions

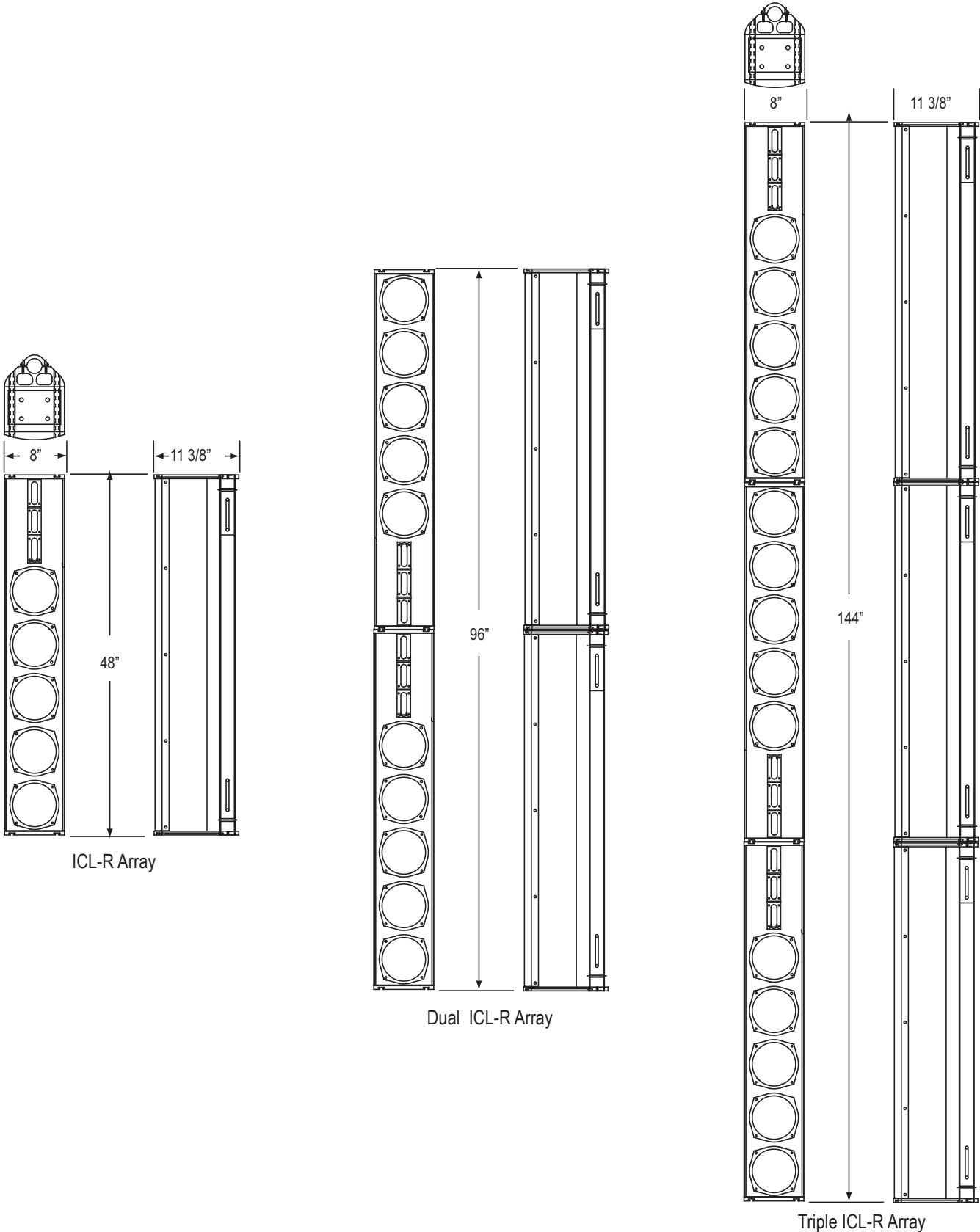

## ICL-R Technical Specifications

- Sensitivity:** 01.0 V (for rated power output)
- Freq. Range:** 80 Hz to 20 kHz
- Max SPL:** 105 dB peak @ 100 Ft. (30.5 meters),  
108 dB peak when stacked  
(3-octave bandwidth centered at 2 kHz)
- Horiz. Dispersion:** 150° up to 3 kHz; 120° above 3 kHz
- Vert. Opening Angles:** 20°, 25° and 30° (5°, 10°, 15° and 20° when stacked)
- Aiming Angle:** Adjustable from -30° to +30°
- Typical Throw:** 66 Ft. (20 m) 132 Ft. (40 m) when stacked
- Beam Control:** Effective down to 800 Hz (400 Hz when stacked)
- No. Transducers:** Five 6.5-inch cone transducers with neodymium magnets  
(per module) Three 1-inch HF titanium nitride compression drivers
- No. Amp. Channels:** 8 (per module)
- Dimensions:** 48" H x 8" W x 11.3" D (121.5 cm x 20. cm x 28.7 cm)
- Weight:** 61 Lbs (27.7 Kg)
- Hanging Method:** AeroQuip Fly-Track
- Enclosure:** Finnish Birch with Aluminum end caps and perforated steel grille; suitable for outdoor use
- Inputs:** **Analog Audio - AES/EBU Inputs:** Looping XLR (female in, male out) and Phoenix 6-pin (looping 3-in, 3-out)  
**CobraNet:** Dual RJ45 connectors (for CAT 5)
- Controls (Rear Mounted):** Mute button; Up & Down Output Level push buttons; 10 dB Input pad (on Analog 1 input), Power On/Off.; Push-To-Reset circuit breaker; Configuration PreSet Selector
- Computer Controls:** Gain; Mute; On/Standby, Input Selection; Compression, 8-Band Parametric EQ, Shelving & Rolloff Filters; Delay, Configuration Preset Readout
- Status Indicators:** Power, Signal, Overdrive, Thermal, Mute, Input Pad, Failure, Preset Configuration
- Power Connector:** Powercon locking connector
- Finish:** Black paint
- Network Digital Format:** 16, 20 or 24 bit PCM; 48 or 96 kHz sample rate; selectable network latency
- DSP/AMPLIFIER**
- Type:** 8-channel, Class D amplifier/DSP processor
- Input Impedance:** >20K Ohm balanced differential
- Max Input:** +24 dBu (Pad in 0; +14 dBu @ 1V sensitivity (Pad out)
- Power Rating:** 100 Watts RMS per channel, 150 Watts Burst
- Freq. Range:** + 3, - 3 dB, 80 Hz to 20 kHz
- THD Distortion:** < 0.05% typical
- Hum & Noise:** <100 dB (A weighted)
- Power Required:** Universal 90/260 VAC, 50/60Hz.  
(per module) 500 VA @ Rated Power Output; 29 VA Idle;  
(4.2 Amps @ RPO at 120 V; 250 ma Idle)

Note: All analog inputs and outputs comply with AES Standard 48-2005 on interconnecting, grounding and shielding.

IC215S-R Dimensions

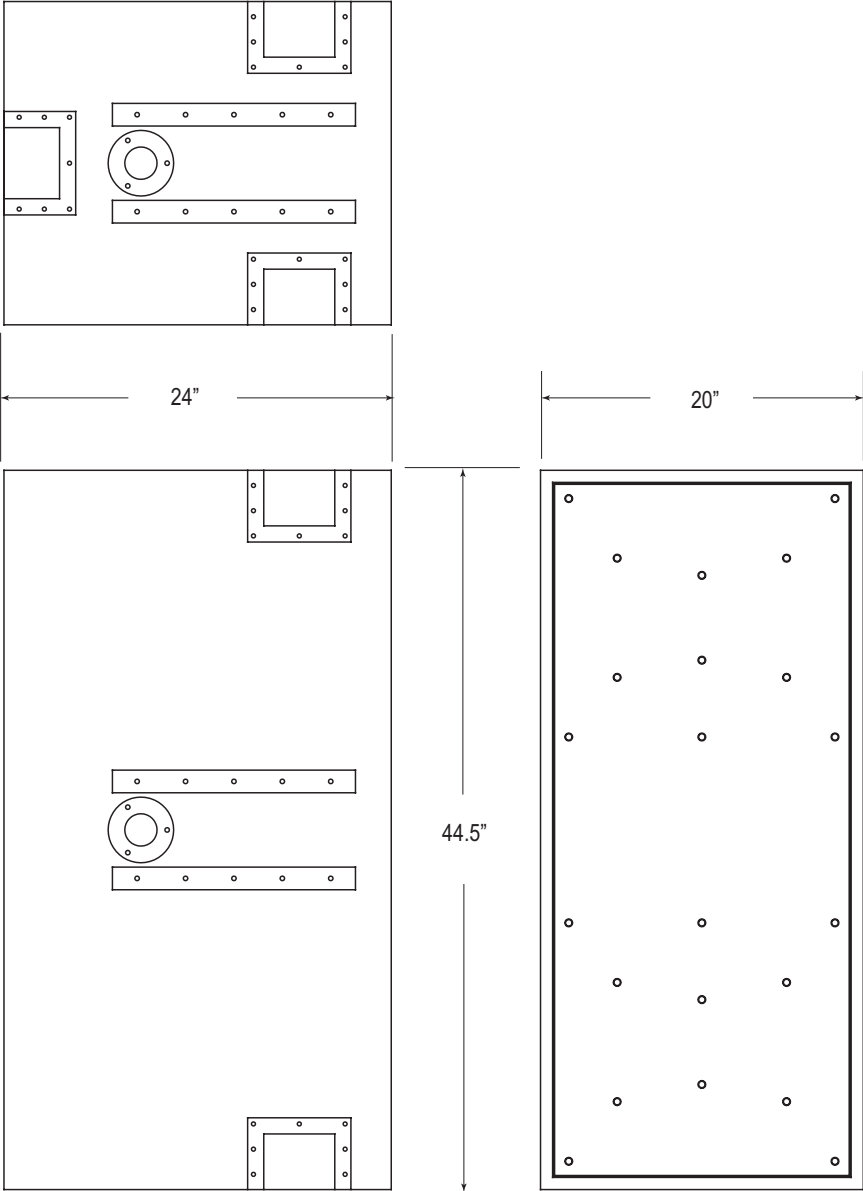

## IC215S-R Technical Specifications

- Sensitivity:** 1.4 V (for rated power output)
- Freq. Range:** 43 Hz to 100 Hz
- Max SPL:** 136 dB peak,
- No. Transducers:** Two model SSL15-14, 15" cone woofers, 800 Watts program at 4 Ohms (each)
- Dimensions:** 44.5" H x 20" W x 24" D (113 cm x 50.8 cm x 61 cm)
- Weight:** 206 Lbs (93.4 Kg)
- Hardware:** Aeroquip Flytrack, Handles, Casters
- Enclosure:** Finnish Birch, perforated steel grille
- Inputs:** Analog Audio Input 1: Looping XLR (female in, male out)  
Analog Audio Input 2: Phoenix 6-pin (looping 3-in, 3-out)  
CobraNet: Dual RJ45 connectors (for CAT 5 copper cable)  
AES/EBU: Phoenix connector
- Controls (Rear Mounted):** Power On/Off, Push-To-Reset circuit breakers  
Mute button;  
Up & Down Output Level push buttons;  
10 dB Input pad (on Analog 1 input)
- Computer Controls:** Gain, Mute, On/Standby, Input Selection  
Compression,  
8-Band Parametric EQ  
Shelving & Rolloff Filters  
Delay
- Status Indicators:** Power, Signal, Overdrive, Thermal, Mute, Input Pad
- Power Connector:** Powercon locking connector
- Finish:** Black paint
- Network Digital Format:** 16, 20 or 24 bit PCM; 48 or 96 kHz sample rat;  
Selectable network latency

### PM-2LR AMPLIFIER

- Type:** Class D amplifier/DSP processor
- Power Rating:** 2 x 850 Watts RMS, 950 W Program
- THD Distortion:** < 0.05% typical
- Hum & Noise** <100 dB (A weighted)
- :Power Required:** 90/136 V or 180/260 V AC, 50/60Hz.  
13 Amps @ 120 V; 6.5 Amps at 240 V  
Idle current; 380 ma @ 120 V; 190 ma @ 240 V

Note: All analog inputs and outputs comply with AES Standard 45-2005 on interconnecting, grounding and shielding.

## Index

### A

Access Control - 46, 47  
 AC power - 10  
 Adding Virtual Devices - 25  
 AES/EBU - 10, 11

Assembly Instructions - 6, 7  
 Assigning Inputs - 16  
 All Loudspeakers - 39  
 Auto-Focus - 36, 37

### B

Beam Steering - 30 to 38  
     Preferences - 32  
     Mapping - 34, 35  
 Bin Files - 52, 53  
 Block Diagrams - 8, 9

### C

CobraNet - 28  
     Bundle - 28, 29  
     Disable Receiver - 29  
     Latency - 28  
     Multicast - 28  
     Receivers (Rx) - 28, 29  
     Sample rate - 28  
     Transmitters (Tx) - 28, 29  
     Unicast - 28

Compression - 17  
 Connect Mode - 14, 16  
 Connect Properties Window - 14, 16  
 Control Mode - 14, 17, 18  
 Control Properties Window - 14, 17  
 Copy Settings / Copy Presets - 41

### D

Delay - 17  
 Designer - 46  
 Dimensions - 63, 65  
 Digital Audio - 16  
     Signal Routing - 28, 29  
     User-configurable DSP Functions - 17

### E

Equalization - 17  
     Filters - 17  
     Parametric - 17

### F

Firmware - 49, 50, 51, 52, 53

### G

Group - 39  
 Group Assign - 40  
 Group Control - 39

### H

Hardware Connections - 10

### I

Inputs - 10, 16  
 Installation - 22, 48, 49  
 Internet - 44  
 Invert - 15  
 IP Addresses - 23, 58  
     Assigning - 23, 58  
     Static - 23, 58

## Index

### L

Latency - 28  
Linking Software Icons & Loudspeakers - 26, 27  
Load Preset - 19

### M

Master / Slave Setup - 7  
Mute - 15  
Microcontroller Firmware - 50, 51

### N

Network - 23, 24  
Network Interface Card - 23, 58  
Network Manager - 24, 57  
Normalize - 34

### O

Operator - 46  
Operator Alerts (Notification) - 44  
    E-mail - 45

### P

Pad - 15  
Panel Controls - 19  
Panel Display - 19  
Password Protection - 46  
Paste Settings - 41  
Power On Sequencing - 45  
Preferences - 45  
Presets - 11, 12, 13, 17, 18, 19, 41

### R

Reset - 41  
RHAON - 22  
    Firmware - 49, 50, 51, 53, 54  
    General Preferences - 45  
    Software Installation - 22, 49

### S

Safety Instructions - 2  
Sample Rate - 28  
Saving Changes - 18, 26, 31, 38  
Saving Your Project - 38  
  
Setups - 5  
Shipping - 4  
Signal Present - 10  
SNMP - 44, 56  
  
Software Installation - 22, 48, 49  
Speaker Protection (Compression) - 17  
Software Updates - 48  
Standby Mode - 11  
Static IP Addresses - 23  
Status Indicators - 15, 42  
  
Supervise Mode - 42, 43, 44  
    Driver conditions - 43  
    Event Logging - 44  
    Event Notification - 44  
Supervisor - 46  
SysTune - 19

### T

Table of Contents - 3  
Technical Specifications - 66, 68  
Technical Support - 4  
Trouble Shooting - 54 to 64

### V

Virtual Systems - 25

### W

Wink light - 15  
Wink with Audio - 15





19201 Cook Street, Foothill Ranch, CA USA  
Phone: +1 949 588 9997 • Fax: +1 949 588 9514  
sales@renkus-heinz.com • www.renkus-heinz.com