



General Description

The Rane MLM65 Mic/Line Mixer is designed for easy manual mixing of up to 6 mic/line inputs and playback of one of several stereo audio sources, including modern USB audio and old school vinyl. Simultaneous digital audio recording of the manual mix to S/PDIF, TOSLINK and/or USB audio provides a formidable mixing ally in today's audio world. The MLM65 features and topology are simple for non-technical operators, and it's dedicated USB Charge port supports the kids' MP3 players.

The MLM65 provides 6 manually mixed mic/line XLR inputs each with a front panel Pan and Level control, plus a window slot atop each input for installer-created labels. These inputs also have independent rear panel screw-driver Gain trims, Over-load indicators, 12 volt Phantom Power and Mic/Line switches.

One of six stereo Aux inputs is selectable on the front panel with a Level fader for the selected source being mixed. A single large window slot for installer-created Aux source labels makes operation simple for newbies. The stereo Aux inputs include five consumer RCA inputs each with screw-driver input gain trim. The Aux 1 input provides an additional 3.5 mm stereo TRS jack and an adjacent dedicated USB Charge port for an iPod or other USB-powered audio device.

For audio sources requiring diamond needles drug through the spiral-grooved black lacquer discs of yore, the Aux 4 input's

phono/line switch satisfies those addicted to the warm even-order harmonic distortion of phono cartridges. A large phono ground post is nearby for added sheen.

The sixth Aux input enters via the USB Audio port. The MLM65 registers as a standard USB audio device with either Windows® or Apple® operating systems, and both incoming and outgoing audio is stereo 16-bit, 48 kHz PCM. This accommodates pristine, far-beyond-CD-quality playback of audio from dozens of instantly compatible laptop software programs.

The front panel Headphone outputs on 1/4" and 3.5 mm TRS jacks have a dedicated meter with peak hold, rotary Level control and are fed audio from the selected/illuminated Cue button. Stereo headphone cueing of any mic, the selected Aux input or the Main mix is supported.

The Main Level fader and meter with gain peak hold on the front affects only the Main stereo XLR Outputs which sport a Mono switch. The stereo Record RCA outputs with screw-driver adjustable attenuator provide a local analog output for recording to MP3 players or nearby camcorders.

The three digital audio outputs of the mix are 24-bit / 48 kHz S/PDIF and TOSLINK, and 16-bit / 48 kHz USB audio. The same laptop can simultaneously playback and record via USB.

Rear Panel

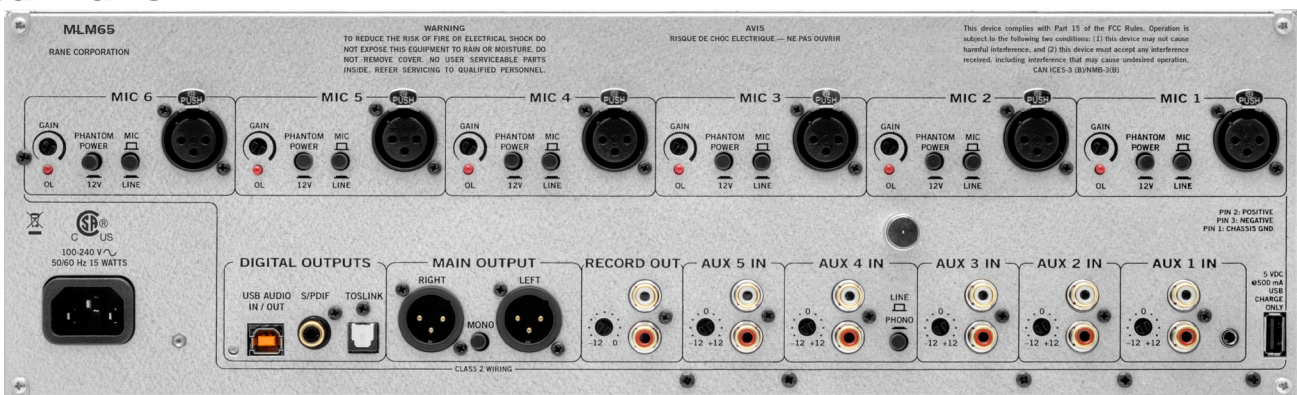

Features and Specifications

Parameter	Specification
Aux Inputs 1,2,3,5	Stereo, Unbalanced, RCA
Maximum Input	+20 dBu
Input Impedance	20 k Ω , 1%
Gain Trim Range	\pm 12 dB
Frequency Response	\pm 0.25 dB, 20 Hz to 20 kHz
Aux Input 4	Stereo, Unbalanced, RCA
Phono/Line	Selectable
Input Impedance	47.5 k Ω , 1%
Gain Trim Range	\pm 12 dB
Line Frequency Response	\pm 0.25 dB, 20 Hz to 20 kHz
Phono Gain	35dB, 1 kHz
Phono Frequency Response	RIAA \pm 0.5 dB, 30 Hz to 20 kHz
Record Output	Stereo, Unbalanced, RCA
Maximum Output	+20 dBu, 10 k Ω load
Output Impedance	200 Ω , 1%
Output Trim Range	0 dB to -12 dB
S/N	>98 dB re +4 dBu, 20Hz to 20 kHz, 0 dB gain
THD+N	< 0.1%, 20Hz to 20 kHz, +4 dBu, 0 dB gain, 10 k Ω load
Main Output	Stereo, Balanced, XLR
Mono/Stereo	Selectable
Maximum Output	+26 dBu, 10 k Ω load per leg
Output Impedance	200 Ω , 1% per leg
S/N	>92 dB re +4 dBu, 20Hz to 20 kHz, 0 dB gain
THD+N	< 0.1%, 20Hz to 20 kHz, +4 dBu, 10 k Ω load per leg
Headphone Output	Stereo, Unbalanced, 1/4" and 3.5mm TRS
Maximum Output Power	180 mW into 150 Ω
Output Volume Range	+4.5 dB to off
Frequency Response	23 Hz to 70 kHz, -3 dB points
S/N	>96 dB re +4 dBu, 20Hz to 20 kHz, 4.5 dB gain
THD+N	< 0.02%, 20Hz to 20 kHz, +4 dBu, 150 Ω load
Master/Cue Meters	Mono, peak detecting
Sensitivity	0 dB indication = 0 dBu (-20 dBFS)
Mic Inputs	Mono, Balanced, XLR
Mic/Line	each Input selectable
Phantom Power	12 V, 681 Ω per leg, each Input selectable
Overload Indication	5.5 dB before clipping
Mic/Line Maximum Input	+12 dBu / +28 dBu, minimum gain
Mic/Line Input Impedance	637 Ω / 4 k Ω per leg
Mic/Line Gain Trim Range	10 dB to 52 dB / -6 dB to 10 dB, typical
Mic/Line Frequency Response	20 Hz (-0.5 dB/-0.5 dB) to 20 kHz (-1.5 dB/-2 dB)
EIN	127 dBu, R _s = 150 Ω , g = 55 dB, 20 Hz to 20 kHz
Mic/Line CMRR	-40 dB, max., 1 kHz
TOSLINK and S/PDIF Outputs	Optical and RCA
Sample Rate	48 kHz
Resolution	24-bit
Dynamic Range	104 dB
THD+N	< 0.02%, 20Hz to 20 kHz, -20 dBFS
USB Digital Audio	Stereo In/Out, USB Type B
Sample Rate	48 kHz
Resolution	16-bit
Dynamic Range	94 dB
THD+N	< 0.04%, 20Hz to 20 kHz, +4 dBu

Parameter	Specification
USB Charge Only Port	USB Type A
Output Voltage	+5 VDC max.
Output Current	+500 mA max.
Unit	
Power Supply Requirement	100 to 240 VAC, 50/60 Hz, .24 amp
Conformity	FCC, cCSAus
Construction	All Steel
Unit Size	5.25"H x 19"W x 5.3"D (3U) (13.3 x 48.3 x 13.5 cm)
Unit Weight	7 lb (3.16 kg)
Shipping Size	11" x 23" x 16" (27.9 x 58.4 x 40.6 cm)
Shipping Weight	11 lb (4.99 kg)
<i>Note: 0 dBu=0.775 Vrms</i>	

System Example

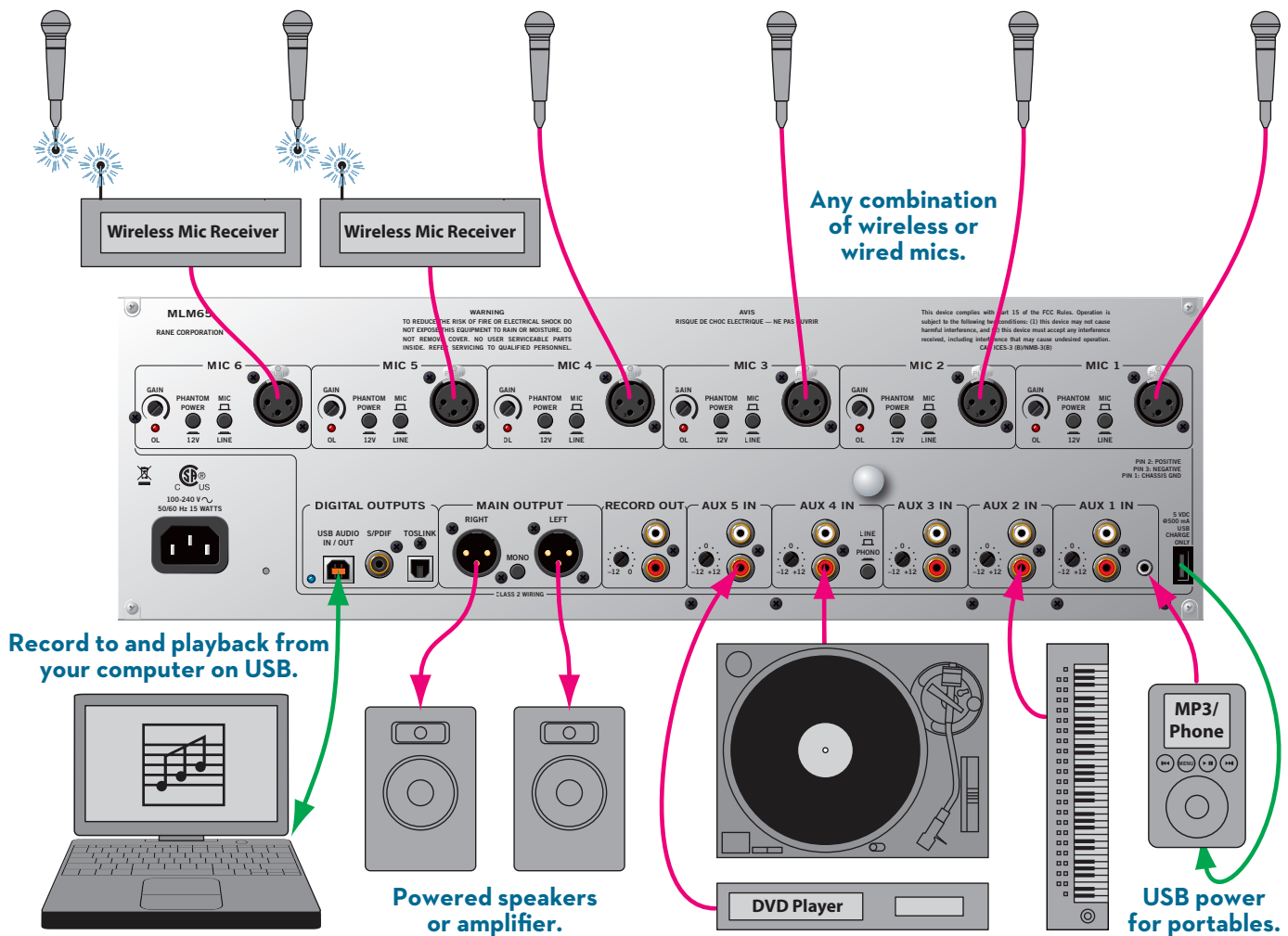

Block Diagram

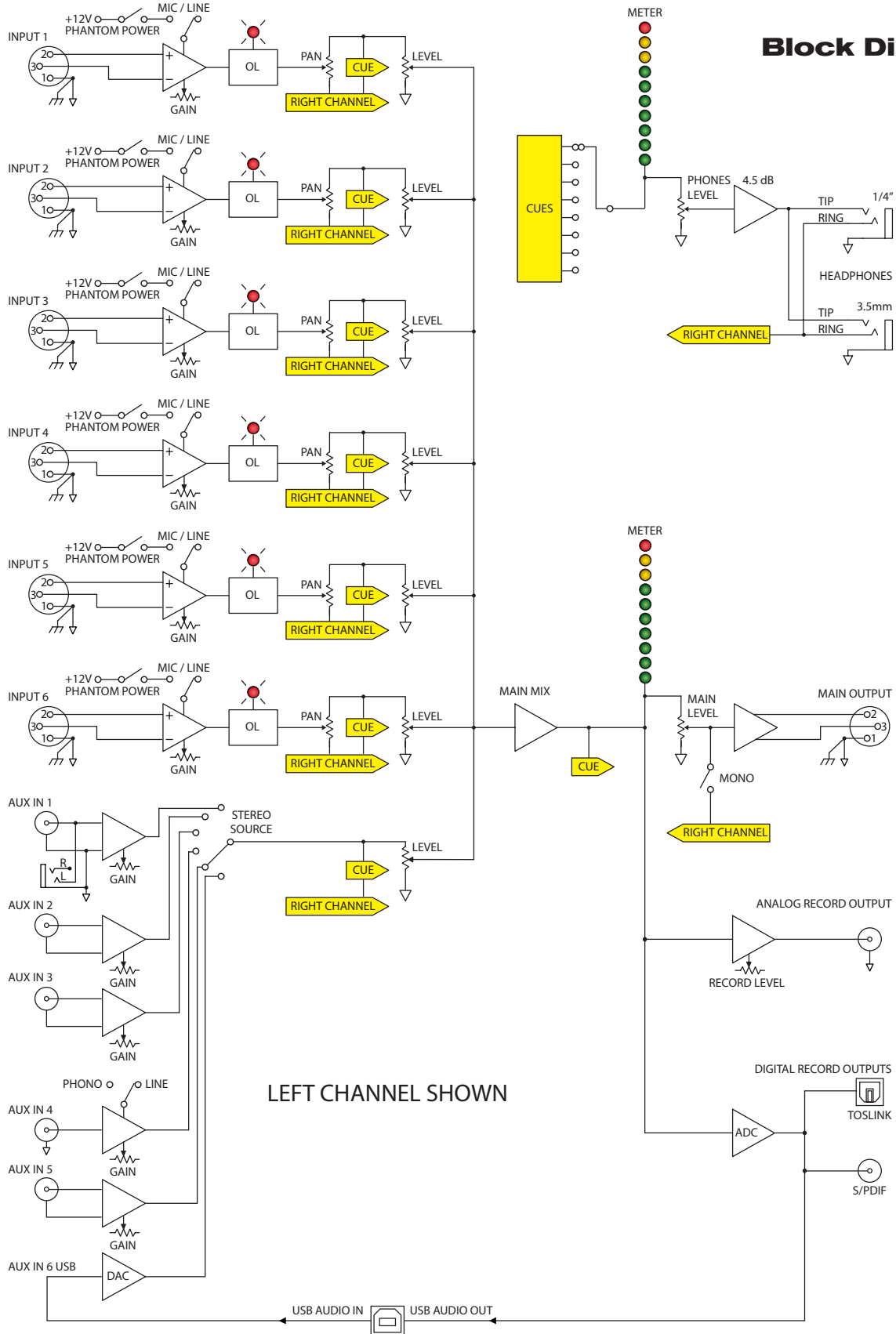

LEFT CHANNEL SHOWN