

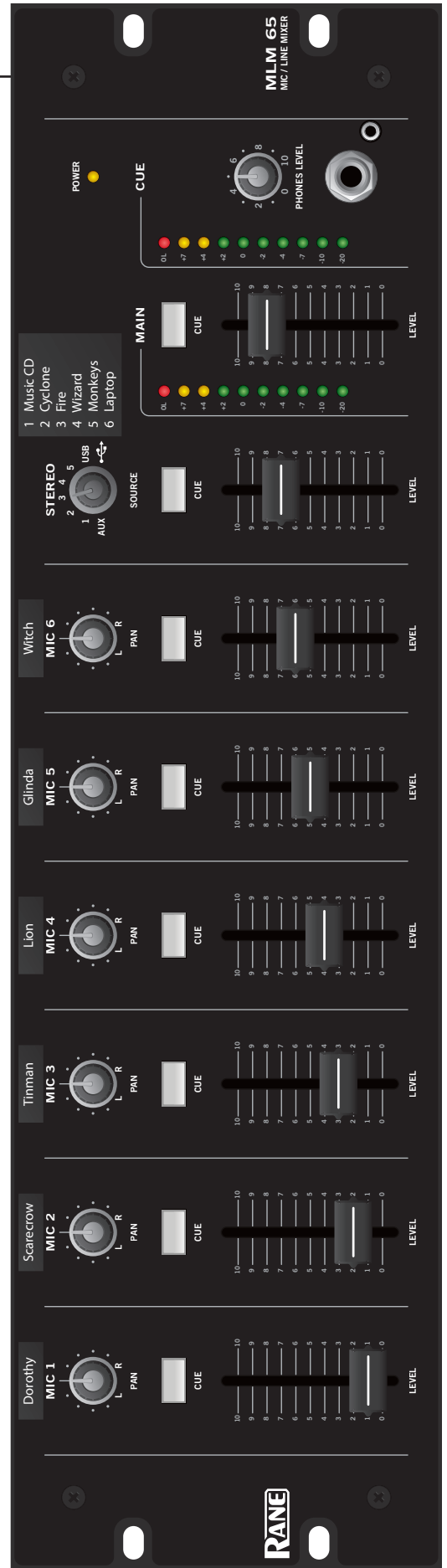

# MLM65

MIC & LINE MIXER



## CONTENTS *(in order of appearance)*

- Important Safety Instructions
- MLM65 Manual
- MLM65 Data Sheet
- Sound System Interconnection
- Warranty
- Declaration of Conformity

Schematics are downloadable at [www.rane.com/mlm65.html](http://www.rane.com/mlm65.html)

# IMPORTANT SAFETY INSTRUCTIONS



1. Read these instructions.
  2. Keep these instructions.
  3. Heed all warnings.
  4. Follow all instructions.
  5. Do not use this apparatus near water.
  6. Clean only with a dry cloth.
  7. Do not block any ventilation openings. Install in accordance with manufacturer's instructions.
  8. Do not install near any heat sources such as radiators, registers, stoves, or other apparatus (including amplifiers) that produce heat.
  9. Do not defeat the safety purpose of the polarized or grounding-type plug. A polarized plug has two blades with one wider than the other. A grounding-type plug has two blades and a third grounding prong. The wide blade or third prong is provided for your safety. If the provided plug does not fit into your outlet, consult an electrician for replacement of the obsolete outlet.
  10. Protect the power cord and plug from being walked on or pinched particularly at plugs, convenience receptacles, and the point where it exits from the apparatus.
  11. Only use attachments and accessories specified by Rane.
  12. Use only with the cart, stand, tripod, bracket, or table specified by the manufacturer, or sold with the apparatus. When a cart is used, use caution when moving the cart/apparatus combination to avoid injury from tip-over.
  13. Unplug this apparatus during lightning storms or when unused for long periods of time.
  14. Refer all servicing to qualified service personnel. Servicing is required when the apparatus has been damaged in any way, such as power supply cord or plug is damaged, liquid has been spilled or objects have fallen into the apparatus, the apparatus has been exposed to rain or moisture, does not operate normally, or has been dropped.
  15. The plug on the power cord is the AC mains disconnect device and must remain readily operable. To completely disconnect this apparatus from the AC mains, disconnect the power supply cord plug from the AC receptacle.
  16. This apparatus shall be connected to a mains socket outlet with a protective earthing connection.
  17. When permanently connected, an all-pole mains switch with a contact separation of at least 3 mm in each pole shall be incorporated in the electrical installation of the building.
  18. If rackmounting, provide adequate ventilation. Equipment may be located above or below this apparatus, but some equipment (like large power amplifiers) may cause an unacceptable amount of hum or may generate too much heat and degrade the performance of this apparatus.
  19. This apparatus may be installed in an industry standard equipment rack. Use screws through all mounting holes to provide the best support.
- WARNING:** To reduce the risk of fire or electric shock, do not expose this apparatus to rain or moisture. Apparatus shall not be exposed to dripping or splashing and no objects filled with liquids, such as vases, shall be placed on the apparatus.

## WARNING



To reduce the risk of electrical shock, do not open the unit. No user serviceable parts inside. Refer servicing to qualified service personnel.

The symbols shown below are internationally accepted symbols that warn of potential hazards with electrical products.



This symbol indicates that a dangerous voltage constituting a risk of electric shock is present within this unit.



This symbol indicates that there are important operating and maintenance instructions in the literature accompanying this unit.

**WARNING:** This product may contain chemicals known to the State of California to cause cancer, or birth defects or other reproductive harm.

**NOTE:** This equipment has been tested and found to comply with the limits for a Class B digital device, pursuant to part 15 of the FCC Rules. These limits are designed to provide reasonable protection against harmful interference in a residential installation. This equipment generates, uses and can radiate radio frequency energy and, if not installed and used in accordance with the instructions, may cause harmful interference to radio communications. However, there is no guarantee that interference will not occur in a particular installation. If this equipment does cause harmful interference to radio or television reception, which can be determined by turning the equipment off and on, the user is encouraged to try to correct the interference by one or more of the following measures:

- Reorient or relocate the receiving antenna.
- Increase the separation between the equipment and receiver.
- Connect the equipment into an outlet on a circuit different from that to which the receiver is connected.
- Consult the dealer or an experienced radio/TV technician for help.

**CAUTION:** Changes or modifications not expressly approved by Rane Corporation could void the user's authority to operate the equipment.

# INSTRUCTIONS DE SÉCURITÉ



1. Lisez ces instructions.
2. Gardez précieusement ces instructions.
3. Respectez les avertissements.
4. Suivez toutes les instructions.
5. Ne pas utiliser près d'une source d'eau.
6. Ne nettoyer qu'avec un chiffon doux.
7. N'obstruer aucune évacuation d'air. Effectuez l'installation en suivant les instructions du fabricant.
8. Ne pas disposer près d'une source de chaleur, c-à-d tout appareil produisant de la chaleur sans exception.
9. Ne pas modifier le cordon d'alimentation. Un cordon polarisé possède 2 lames, l'une plus large que l'autre. Un cordon avec tresse de masse possède 2 lames plus une 3<sup>e</sup> pour la terre. La lame large ou la tresse de masse assurent votre sécurité. Si le cordon fourni ne correspond pas à votre prise, contactez votre électricien.
10. Faites en sorte que le cordon ne soit pas piétiné, ni au niveau du fil, ni au niveau de ses broches, ni au niveau des connecteurs de vos appareils.
11. N'utilisez que des accessoires recommandés par Rane.
12. N'utilisez que les éléments de transport, stands, pieds ou tables spécifiés par le fabricant ou vendu avec l'appareil. Quand vous utilisez une valise de transport, prenez soin de vous déplacer avec cet équipement avec prudence afin d'éviter tout risque de blessure.
13. Débranchez cet appareil pendant un orage ou si vous ne l'utilisez pas pendant un certain temps.
14. Adressez-vous à du personnel qualifié pour tout service après vente. Celui-ci est nécessaire dans n'importe quel cas où l'appareil est abîmé : si le cordon ou les fiches sont endommagés, si du liquide a été renversé ou si des objets sont tombés sur l'appareil, si celui-ci a été exposé à la pluie ou l'humidité, s'il ne fonctionne pas correctement ou est tombé.
15. La fiche du cordon d'alimentation sert à brancher le courant alternatif AC et doit absolument rester accessible. Pour déconnecter totalement l'appareil du secteur, débranchez le câble d'alimentation de la prise secteur.
16. Cet appareil doit être branché à une prise terre avec protection.
17. Quand il est branché de manière permanente, un disjoncteur tripolaire normalisé doit être incorporé dans l'installation électrique de l'immeuble.
18. En cas de montage en rack, laissez un espace suffisant pour la ventilation. Vous pouvez disposer d'autres appareils au-dessus ou en-dessous de celui-ci, mais certains (tels que de gros amplificateurs) peuvent provoquer un buzz ou générer trop de chaleur au risque d'endommager votre appareil et dégrader ses performances.
19. Cet appareil peut-être installé dans une baie standard ou un châssis normalisé pour un montage en rack. Visser chaque trou de chaque oreille de rack pour une meilleure fixation et sécurité.

**ATTENTION:** afin d'éviter tout risque de feu ou de choc électrique, gardez cet appareil éloigné de toute source d'humidité et d'éclaboussures quelles qu'elles soient. L'appareil doit également être éloigné de tout objet possédant du liquide (boisson en bouteilles, vases,...).

## ATTENTION



Afin d'éviter tout risque de choc électrique, ne pas ouvrir l'appareil. Aucune pièce ne peut être changée par l'utilisateur. Contactez un SAV qualifié pour toute intervention.

Les symboles ci-dessous sont reconnus internationalement comme prévenant tout risque électrique.



Ce symbole indique que cette unité utilise un voltage élevé constituant un risque de choc électrique.



Ce symbole indique la présence d'instructions d'utilisation et de maintenance importantes dans le document fourni.

**REMARQUE:** Cet équipement a été testé et approuvé conforme aux limites pour un appareil numérique de classe B, conformément au chapitre 15 des règles de la FCC. Ces limites sont établis pour fournir une protection raisonnable contre tout risque d'interférences et peuvent provoquer une énergie de radiofréquence s'il n'est pas installé et utilisé conformément aux instructions, peut également provoquer des interférences aux niveaux des équipements de communication. Cependant, il n'existe aucune garantie que de telles interférences ne se produiront pas dans une installation particulière. Si cet équipement provoque des interférences en réception radio ou télévision, ceci peut être détecté en mettant l'équipement sous/hors tension, l'utilisateur est encouragé à essayer de corriger cette interférence par une ou plusieurs des mesures suivantes:

- Réorienter ou déplacer l'antenne de réception.
- Augmenter la distance entre l'équipement et le récepteur.
- Connecter l'équipement à une sortie sur un circuit différent de celui sur lequel le récepteur est branché.
- Consulter un revendeur ou un technicien radio / TV expérimenté.

**ATTENTION:** Les changements ou modifications non expressément approuvés par Rane Corporation peuvent annuler l'autorité de l'utilisateur à manipuler cet équipement et rendre ainsi nulles toutes les conditions de garantie.

CAN ICES-3 (B)/NMB-3(B)



Cartons et papier à recycler.

**RANE**

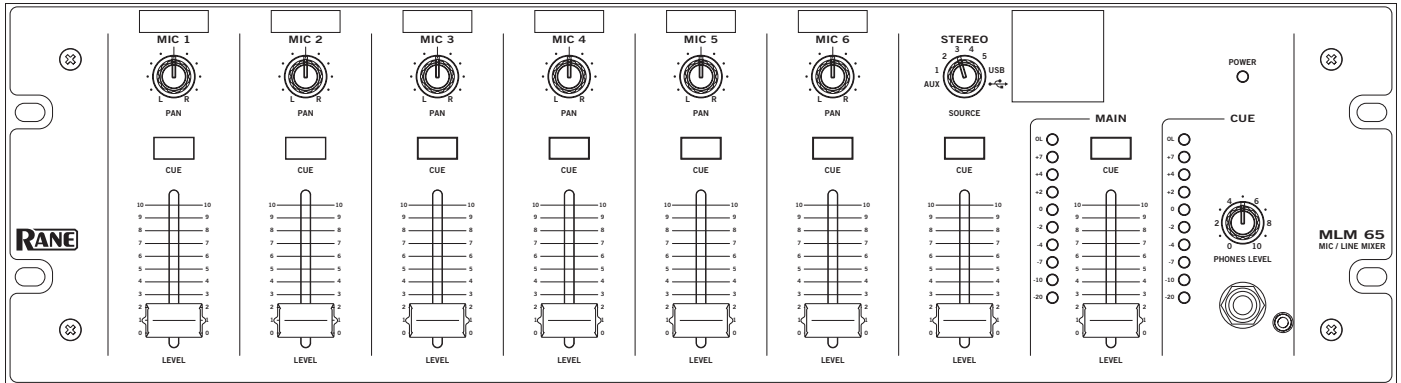

### QUICK START

Are you being pursued by a slow-moving, yet tenacious, gang of zombies? Do you need to get your new MLM65 installed before they overwhelm you and eat your brain? Well, we at Rane are here to help! Use this Quick Start to get the most out of your MLM65 in the least amount of time.

Mic Inputs 1 through 6 may be microphone or line-level. The choice between the two is made by pushing in the Input's Line button on the rear panel.

Push the Phantom Power (when needed) for each Mic Input.

While speaking/singing/shouting loudly into the microphone, use a screwdriver to adjust the Gain pot until the OL LED illuminates only during extreme peaks.

Push in the Aux 4 phono/line switch if you are connecting a phonograph.

With the Stereo Cue button selected, match the input levels of Aux 1 through 5 by playing typical program material into each Aux input, selecting that input using the Stereo Selector, and adjusting the Aux input level with a screwdriver until the peaks on the Cue Meter hover around 0 to +7 dB.

With an audio mix playing at a loud level +7 dB to OL on the Main Meter, adjust the Record Out level until the meter on your recording device gets close to maximum without overloading.

If you are installing the MLM65 with input sources that don't change, Rane has an easy PDF template to fill out, print, cut, and place labels above each input. Download this at the MLM65 web page at [www.rane.com/mlm65.html](http://www.rane.com/mlm65.html).

Look out behind you! Scissors are ineffective on zombies.

### CONNECTION

When connecting the MLM65 to other components in your system for the first time, leave the power cord for last. This gives you a chance to make mistakes and correct them without damage to your fragile speakers, ears and nerves.

#### MIC INPUTS

The six XLR jacks provided on the MLM65 are balanced MIC/LINE inputs. They also accept unbalanced connections. Use only shielded cable for inputs. For best noise rejection use two-conductor-plus-shielded wire, even for unbalanced operation. Connect the shield at both ends to help insure proper grounding. See the Sound System Interconnection RaneNote for all cable adaptations. Rane follows the AES recommended practice of pin 2 positive, pin 3 negative, and pin 1 to shield. Switch any input connected to a microphone to the MIC position (out) using the associated switches on the rear panel. When connecting line-level signals, switch the input to the LINE position (in). A phantom power switch is provided for each MIC input. If LINE is selected, Phantom Power is disabled for that input.

#### AUX INPUTS

The five Aux Inputs are line-level unbalanced inputs on stereo RCA connectors. AUX 1 includes a 3.5 mm stereo TRS jack. Only connect to one AUX 1 input (RCA or TRS) at a time. When using AUX 4 as a phono input, connect the phonograph ground wire to the phono ground post above the AUX 4 input.

#### MAIN OUTPUT

The MLM65's Main Outputs are balanced, XLR Outputs. The same wiring conventions as the XLR Inputs apply. For unbalanced Output connections do not tie pin 3 (i.e., "-") to ground. If the Main Output is connected to a mono loudspeaker system, use either the left or right Main output jack and push in the MONO switch.

*continued on page Manual-4...*

## FRONT PANEL DESCRIPTION

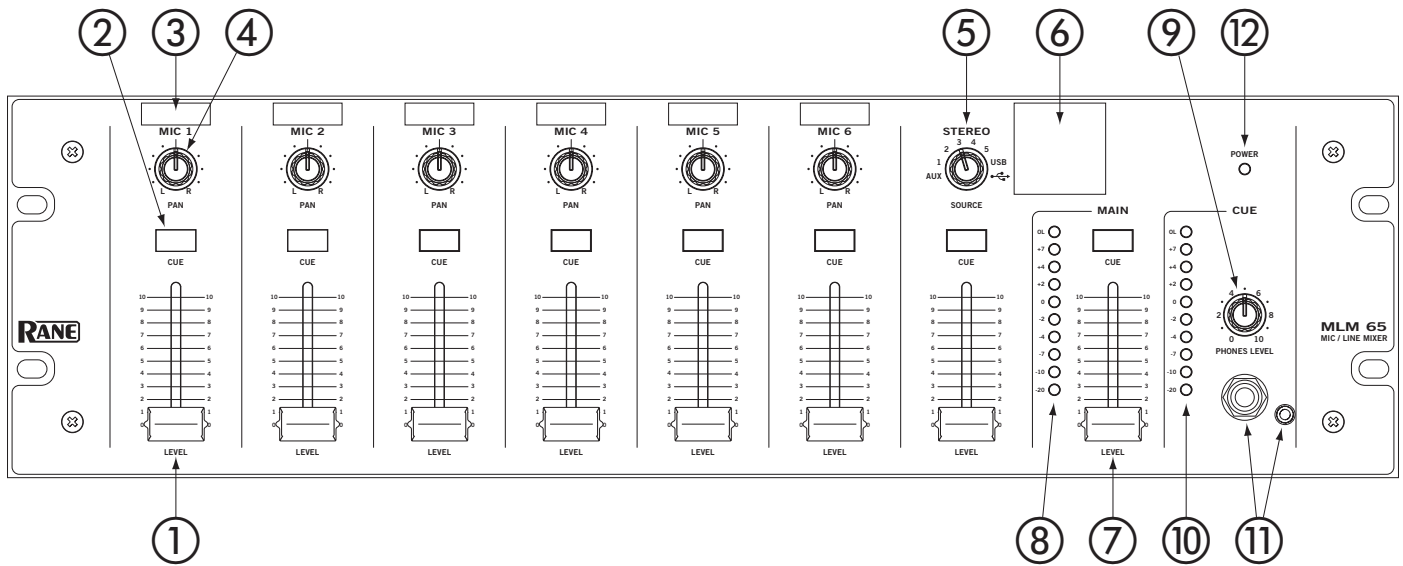

- ① **Input LEVEL faders** are 45 mm sliders that set the volume of each mic or line Input.
- ② **CUE buttons** select one of the Inputs, the Stereo Aux, or the Main Mix to be heard in headphones, and displayed on the Cue meter. The button lights yellow when active. The Cue signal is before the Level fader, allowing the user to hear a source in the headphones before bringing it into the Main Mix. Only one Cue source is heard at a time.
- ③ **Input label slots 1-6** allow you to print your own label for each connected Input, and slip it behind the window. A PDF template is downloadable from [www.rane.com](http://www.rane.com) on the MLM65 page. Cut each label to 1" x .375" [ $\frac{3}{8}$ "] (2.5 x .9 cm).
- ④ **PAN controls 1-6** send the input audio to both left and right Main Mix channels when in the center (at 12 o'clock). The signal moves to the left channel when turned counter-clockwise, and to the right channel when turned clockwise.
- ⑤ **STEREO SOURCE** selects the signal for the Aux Input. Choose from AUX 1, 2, 3, 4, 5 or USB playback from a computer.
- ⑥ **Stereo Input Label Slot** allows you to print a list of input labels and slip it behind the window. A PDF template is downloadable from [www.rane.com](http://www.rane.com) on the MLM65 page. Cut the label to 1.25" x 1.25" [ $1\frac{1}{4}$ "] (3.2 x 3.2 cm).
- ⑦ **MAIN LEVEL fader** is a 45 mm slider that sets the Main Mix volume at the Main Outputs.
- ⑧ **Main Mix meter** displays the sum of all Inputs sent to the Main Mix. This audio level is sent to the Main Level fader, the rear panel Record Out gain control, and the TOSLINK, S/PDIF, and USB digital outputs. The Main Level fader has no effect on this display. The 0 dB LED corresponds to a level of -20 dBFS (20 dB before clipping).
- ⑨ **CUE: PHONES LEVEL control** sets the volume of the input selected with the lit Cue button to the stereo headphone outputs.
- ⑩ **CUE: meter** displays the signal level of the input selected with the lit Cue button. The Phones Level control has no effect on this display. The 0 dB LED corresponds to a level of -20 dBFS. The Cue meter is also a convenient way to match input levels. Drive all inputs with representative input signals, Cue each input individually, and adjust the rear panel input gain trim of each Cued Input until the Cue meter indicates 0 dB rms.
- ⑪ **CUE: headphone outputs** accept both 1/4" and 3.5 mm stereo headphone plugs.
- ⑫ **POWER indicator** lights whenever adequate power is applied to the unit.

## REAR PANEL DESCRIPTION

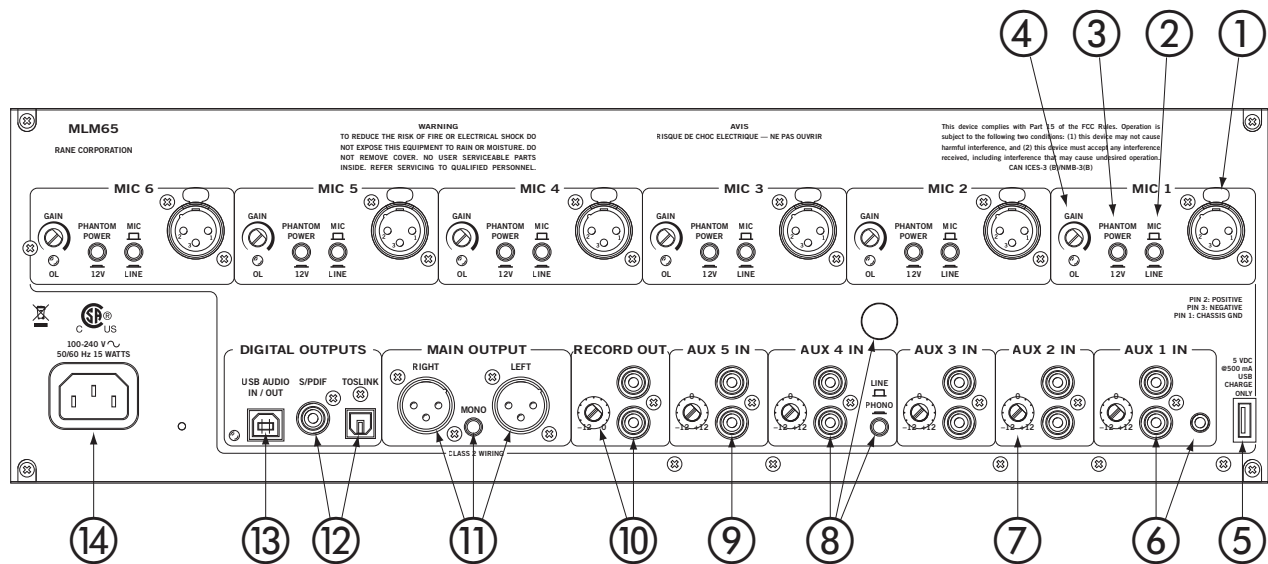

- ① **MIC/LINE INPUTS 1-6** are balanced XLR input jacks. Pin 1 is chassis ground (neutral), pin 2 is positive (+), and pin 3 is negative (-).
- ② **MIC/LINE INPUT buttons 1-6** switch the sensitivity and input impedance for microphone or line-level input. If LINE is chosen, phantom power is defeated for that input.
- ③ **PHANTOM POWER buttons 1-6** apply 12V phantom power to the input if the Mic/Line button is set to MIC.
- ④ **MIC/LINE INPUT GAIN trims 1-6** adjust the preamp gain for the Mic/Line Input. The OverLoad indicator lights when the input signal level is within 5 dB of clipping. The Mic/Line Gain Trim may be decreased to provide more headroom if necessary.
- ⑤ **USB CHARGE port** provides up to 500 mA at 5V to allow an MP3 player to charge its battery during playback.
- ⑥ **AUX 1 Stereo Input** provides a **3.5 mm** TRS input as a convenience for connecting an MP3 player or other portable device. Connect a 3.5 mm stereo audio cable from a docking station, or headphone output of the player, to this 3.5mm input jack. Connect USB cable from the docking station or MP3 player to the adjacent USB charge port ⑤. An RCA stereo line input is also provided. However, use only one of these AUX 1 Inputs at a time, do not use both at once.
- ⑦ **AUX 1-5 Input Gain Trim** on each AUX input allows the system installer to match the relative input signal levels of various professional and consumer input devices (CD/DVD players, tape decks, MP3 players, phonographs, keyboards, etc).
- ⑧ **AUX 4 Stereo Input** provides a **LINE/PHONO switch**. When set to PHONO, this switch engages an RIAA equalization filter to accept input from a phonograph. Connect the ground cable from the phonograph to the phono ground post above the Phono switch. When set to LINE, this input accepts any stereo line signal.
- ⑨ **AUX 1-5 Stereo RCA Inputs** in stereo pairs accommodate professional consumer-level unbalanced inputs. White = left channel, and red = right channel.
- ⑩ **RECORD OUT** stereo RCA jack outputs the Main Mix, unaffected by the Main Level fader, at a level dictated by the adjacent record output level trim.
- ⑪ **MAIN OUTPUT** is balanced stereo XLR jacks that output the Main Mix, with volume set by the Main Level fader. A mono version of the Main Mix is output here if the **MONO** switch is engaged, with the same mix appearing on both outputs. Pin 1 is chassis ground (neutral), pin 2 is positive (+), and pin 3 is negative (-).
- ⑫ **DIGITAL OUTPUTS** deliver the Main Mix, unaffected by the Main Level fader. The **TOSLINK** optical jack and/or the **S/PDIF** coaxial jack may be input to CD recorders or other digital recording devices. Both digital outputs operate at 24-bit resolution and 48 kHz sample rate.

⑬ **USB AUDIO IN / OUT** jack provides a stereo record and playback audio interface to a personal computer. The class-compliant USB audio interface is supported by native drivers on Windows and Macintosh operating systems. This USB stereo input is available as a source for the AUX Input (see front panel ⑤). The USB stereo output carries the Main Mix unaffected by the Main Level fader, and may be used to record the Main Mix using computer software. The blue LED next to the USB AUDIO jack illuminates when the MLM65 is recognized by the computer.

⑭ The IEC appliance input jack uses a C5 cord, connected to AC mains using a line cord appropriate for your area. The high efficiency switching power supply used in the MLM65 operates at voltages from 100 to 240 VAC, 50 or 60 Hz. To prevent accidental shutoff, there is no front panel power switch.

*CONNECTION, continued from page Manual-1.*

### **RECORD OUTPUT**

The analog Record Output is a line-level unbalanced output on a stereo RCA connector. The adjacent level control adjusts the record output level, while the front panel Main Level does not.

### **S/PDIF AND TOSLINK OUTPUTS**

A 75 ohm cable with RCA plugs connects to the S/PDIF output of the MLM65. A TOSLINK (optical) cable connects to the TOSLINK output. Both digital outputs operate at 24-bit resolution and 48 kHz sample rate.

### **USB CONNECTION**

The USB AUDIO IN / OUT port on the MLM65 carries one stereo channel of audio in each direction. This USB audio interface is configured to use the audio device drivers that ship with Windows and Macintosh operating systems. When the operating system recognizes the MLM65's USB audio interface, the blue LED next to the USB AUDIO jack illuminates.

### **USB CHARGE PORT**

The USB charge port supplies up to 500 mA @ 5V to connected devices, allowing them to charge their battery. The port is configured to be recognized as a charge-only host port by the industry's most popular personal media players.

### **HEADPHONES**

Shielded 1/4" and 3.5 mm TRS jacks are provided for connecting headphones. We recommend only connecting one pair of headphones at a time for best output.

## **OPERATION**

### **MONO MICROPHONE/LINE LEVEL INPUTS 1-6**

The rear-panel MIC INPUT GAIN adjusts the input gain before the front panel PAN and LEVEL controls. When an Input's MIC/LINE button is in the "out" position (MIC level), the gain range is 12 to 60 dB. When this button is in the "in" position (LINE-level), the gain range is -4 to 12 dB. To adjust, input some "loud" source material. Then using a screwdriver, adjust the GAIN for each Input so the rear panel OL LED illuminates only occasionally during extreme peaks.

Some microphones (usually called condenser mics) require phantom power to operate. Push the PHANTOM POWER button (when needed) for each Input. If the MIC/LINE button is engaged (LINE-level), Phantom Power is automatically defeated for that Input. The PHANTOM POWER button activates 12 volts which is sufficient power for all but the most esoteric condenser mics. If in doubt, check the manufacturer's mic specs.

Pan each Input to the desired stereo image using the PAN knobs. The 45 mm LEVEL fader on each Input can now be adjusted to set the relative levels of each input in the main mix.

### **STEREO AUX INPUTS 1-5**

The Stereo Source Selector and Level Fader control which stereo source is included in the Main Mix, and at what level.

AUX 1 includes a 3.5 mm stereo TRS jack. Only connect to one AUX 1 input (RCA or TRS) at a time.

AUX 4 includes an RIAA filter when PHONO is selected using the LINE/PHONO switch. When connecting a phonograph, connect its ground wire to the ground lug above the Aux 4 input.

Each rear panel Aux Input level control adjusts the gain of the AUX *source device* before it reaches the front panel Stereo selector switch. The Input Level controls may be used to match the input levels of various stereo *program material*. Use the following procedure to match the Aux Input levels.

1. Set the Stereo Fader LEVEL to minimum.
2. Select the Stereo CUE button.
3. Play typical program material on an AUX source.
4. Select that source using the Stereo selector.
5. Using a screwdriver, adjust the rear panel input gain for that source until the CUE Meter hovers between 0 and +7 dB.
6. Repeat from step 3) for all connected Aux Inputs.

### **MIXING**

The faders on the Mic 1-6 and Stereo input channels control the level of the corresponding inputs in the mix. The Main meter displays the peak level of the mix (pre-Main fader). A mix with optimal dynamic range normally lights the meter from 0 to +7 dB, and only lights the red OL led during the most extreme peaks. A peak indication 0 dB on the meter corresponds to -20 dBFS in the mix (20 dB below clipping). The stereo Main Mix is sent to the Record Outputs, Digital Outputs and the Main Level fader.

## RECORDING

The stereo Main Mix is output (pre-Main Level) from the analog (RCA) Record Output, digital TOSLINK optical Output (24-bit, 48k Hz), digital S/PDIF coaxial Output (24-bit, 48k Hz), and Digital USB audio record output (16-bit, 48k Hz). The analog Record Output includes a level control which may be used to attenuate the analog record signal to avoid overloading the input of the recording device.

## MAIN OUTPUT

The left and right Main Outputs transmit the stereo Main Mix after it is attenuated by the Main fader. The rear-panel Mono switch affects only the Main Output (the Digital Main Mix and Record Outputs remain stereo).

## HEADPHONES AND CUEING

The solo Cue buttons on the front panel select which stereo Input is sent to the headphones. The Cued Input is sent to the headphones pre-fader, so that the Input may be monitored before including it in the Main Mix or sending it to the Main Outputs. The Cue Meter indicates the peak level of the Cued signal (pre-Phones Level). The Phones Level adjusts the headphone volume. We recommend you turn down the volume when putting on your headphones or cueing a new channel, to avoid hurting your ears and throwing your headphones across the room.

## USB RECORDING AND PLAYBACK

The MLM65 includes a USB audio interface providing simultaneous stereo playback and recording (16-bit, 48 kHz). The MLM 65 uses the drivers that ship with Windows and Macintosh operating systems. Once the operating system recognizes the MLM65, the blue LED on the MLM65 rear-panel illuminates.

## WINDOWS OPERATION

When Windows detects the MLM65 it automatically sets it as the default Recording and Playback device. With Windows XP and Vista, any audio applications currently running will continue to use the previously selected default device. Restart the application to make it use the MLM65 for recording or playback. Windows 7 and 8 automatically switch a running application to the newly connected MLM65. We recommend you keep the Stereo Fader down when connecting to avoid surprises.

Remember that Windows likes to play different bleeps and bloops when updates install, devices are plugged in and unplugged, or other operating system events happen. If you do not want these sounds played into your mix, turn off Windows system sounds. This can be found in:

Start -> Control Panel -> Sound -> Sounds (tab) -> Sound Scheme -> No Sounds.

Finding the audio properties and devices in Windows varies slightly with each version.

## Windows XP:

Classic View

Start -> Control Panel -> Sounds and Audio Devices -> Audio (tab)

Category View

Start -> Control Panel -> Sounds, Speech, and Audio Devices -> Sounds and Audio Devices -> Audio (tab)

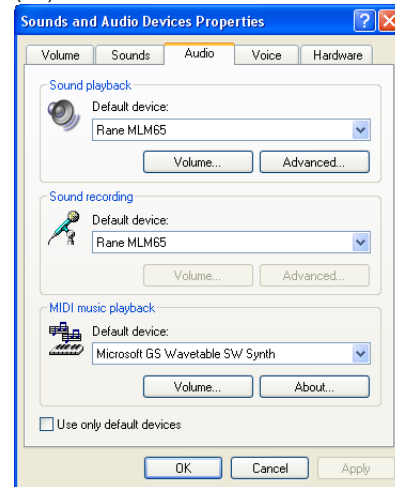

## Windows Vista:

Classic View

Start -> Settings -> Control Panel -> Sound -> Playback (tab) and Record (tab)

Control Panel Home

Start -> Control Panel -> Hardware and Sound -> Sound -> Playback (tab) and Record (tab)

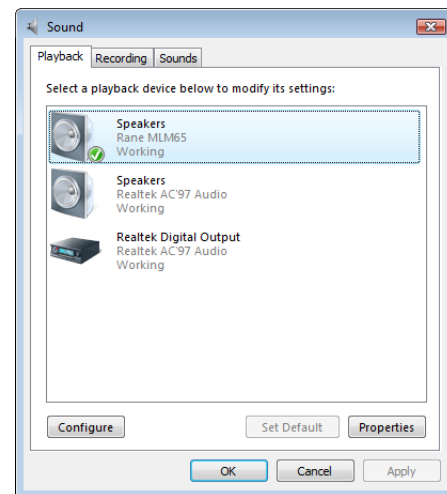

## Windows 7 and 8:

Small/Large Icon View

Start -> Control Panel -> Sound -> Playback (tab) and Record (tab)

Category View

Start -> Control Panel -> Hardware and Sound -> Sound -> Playback (tab) and Record (tab)

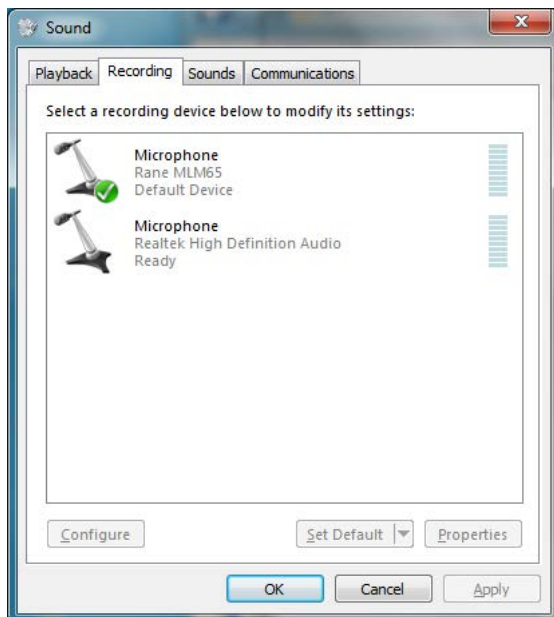
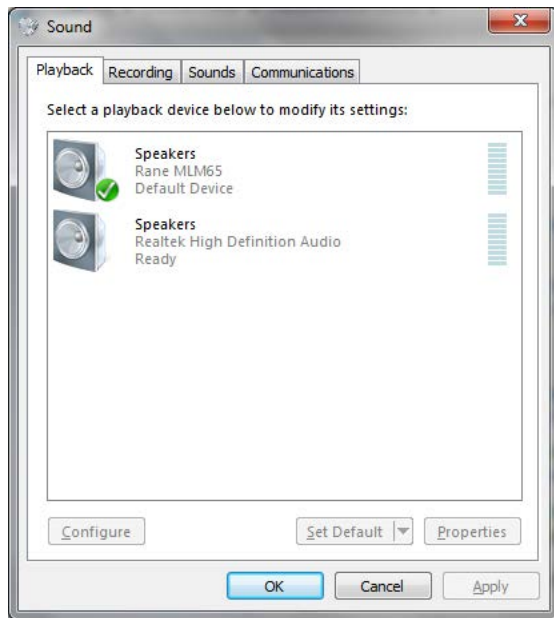

## MACINTOSH OPERATION

When OSX detects the MLM65 it adds it to the list of audio input and output devices, but does not automatically set it as the default device. Some Macintosh applications allow you to select the device you want to use. Other applications only use the device specified as the OSX default. We recommend that you set the default audio input and output device to the MLM65 before starting the application you want to use.

Configure the default audio device in OSX by navigating to: System Preferences -> Sound -> Output (tab) and Input (tab).

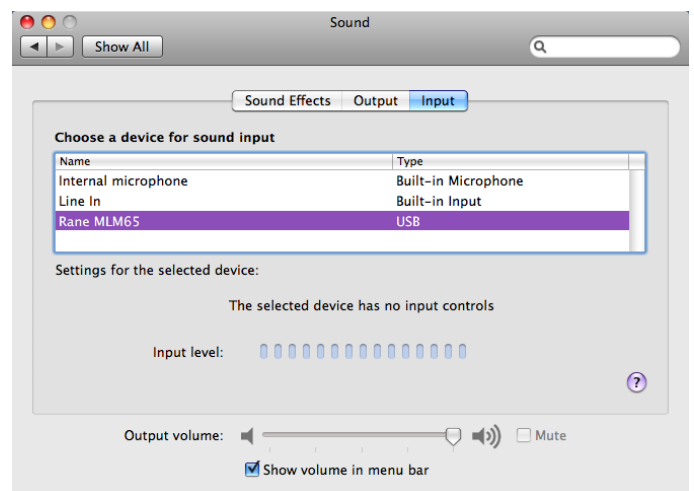
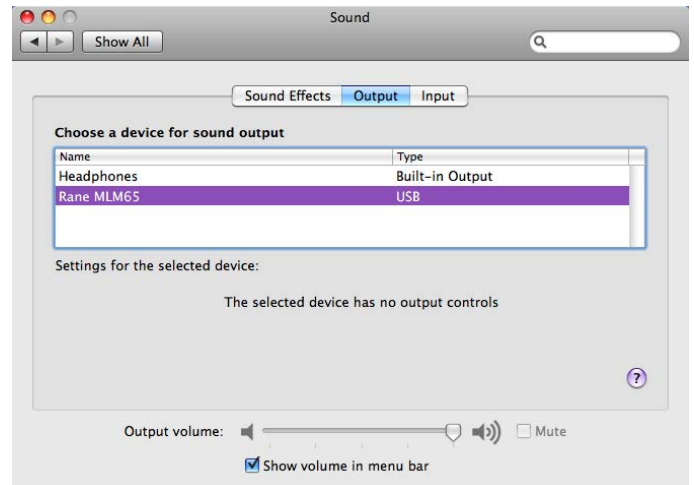

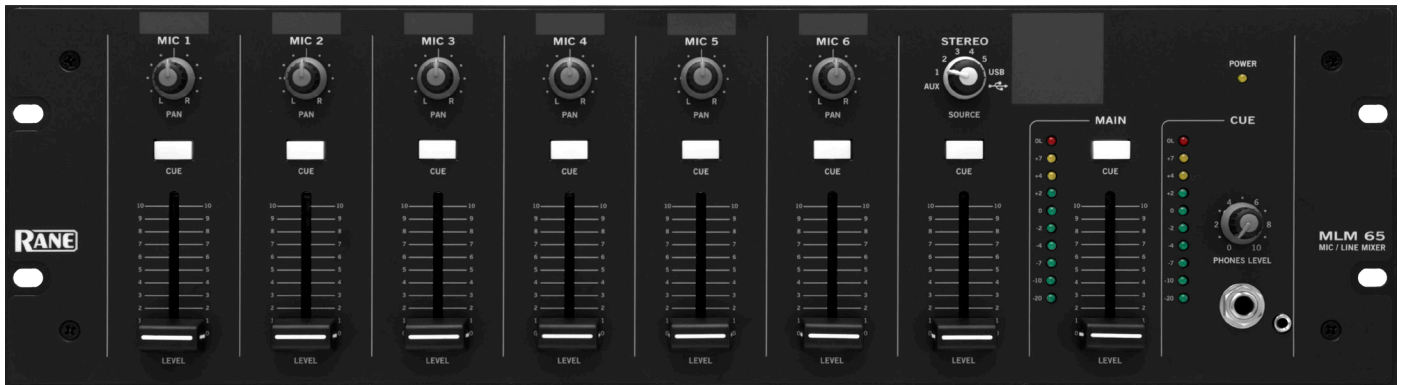

**General Description**

The Rane MLM65 Mic/Line Mixer is designed for easy manual mixing of up to 6 mic/line inputs and playback of one of several stereo audio sources, including modern USB audio and old school vinyl. Simultaneous digital audio recording of the manual mix to S/PDIF, TOSLINK and/or USB audio provides a formidable mixing ally in today's audio world. The MLM65 features and topology are simple for non-technical operators, and it's dedicated USB Charge port supports the kids' MP3 players.

The MLM65 provides 6 manually mixed mic/line XLR inputs each with a front panel Pan and Level control, plus a window slot atop each input for installer-created labels. These inputs also have independent rear panel screw-driver Gain trims, Overload indicators, 12 volt Phantom Power and Mic/Line switches.

One of six stereo Aux inputs is selectable on the front panel with a Level fader for the selected source being mixed. A single large window slot for installer-created Aux source labels makes operation simple for newbies. The stereo Aux inputs include five consumer RCA inputs each with screw-driver input gain trim. The Aux 1 input provides an additional 3.5 mm stereo TRS jack and an adjacent dedicated USB Charge port for an iPod or other USB-powered audio device.

For audio sources requiring diamond needles drug through the spiral-grooved black lacquer discs of yore, the Aux 4 input's

phono/line switch satisfies those addicted to the warm even-order harmonic distortion of phono cartridges. A large phono ground post is nearby for added sheen.

The sixth Aux input enters via the USB Audio port. The MLM65 registers as a standard USB audio device with either Windows® or Apple® operating systems, and both incoming and outgoing audio is stereo 16-bit, 48 kHz PCM. This accommodates pristine, far-beyond-CD-quality playback of audio from dozens of instantly compatible laptop software programs.

The front panel Headphone outputs on 1/4" and 3.5 mm TRS jacks have a dedicated meter with peak hold, rotary Level control and are fed audio from the selected/illuminated Cue button. Stereo headphone cueing of any mic, the selected Aux input or the Main mix is supported.

The Main Level fader and meter with gain peak hold on the front affects only the Main stereo XLR Outputs which sport a Mono switch. The stereo Record RCA outputs with screw-driver adjustable attenuator provide a local analog output for recording to MP3 players or nearby camcorders.

The three digital audio outputs of the mix are 24-bit / 48 kHz S/PDIF and TOSLINK, and 16-bit / 48 kHz USB audio. The same laptop can simultaneously playback and record via USB.

**Rear Panel**

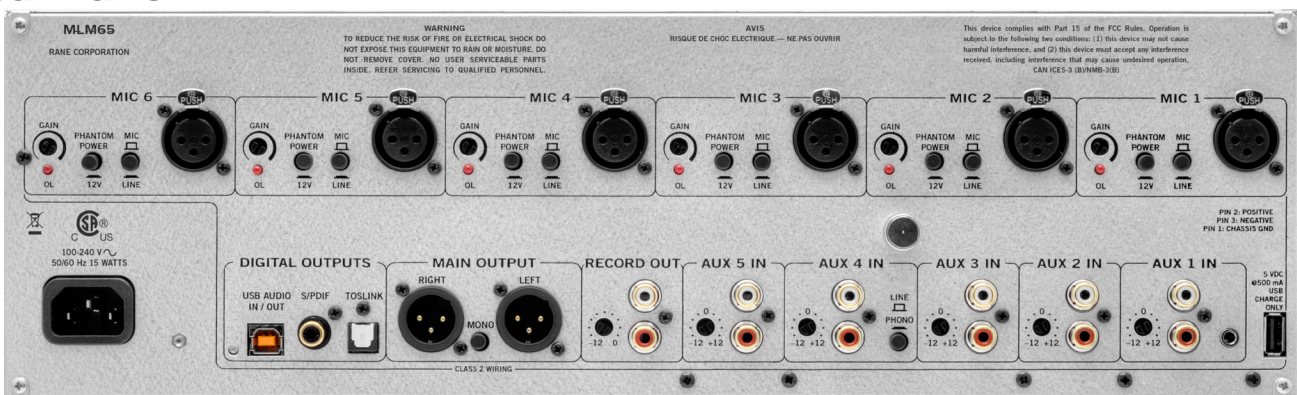

**Features and Specifications**

Parameter	Specification
<b>Aux Inputs 1,2,3,5</b>	Stereo, Unbalanced, RCA
Maximum Input	+20 dBu
Input Impedance	20 k $\Omega$ , 1%
Gain Trim Range	$\pm$ 12 dB
Frequency Response	$\pm$ 0.25 dB, 20 Hz to 20 kHz
<b>Aux Input 4</b>	Stereo, Unbalanced, RCA
Phono/Line	Selectable
Input Impedance	47.5 k $\Omega$ , 1%
Gain Trim Range	$\pm$ 12 dB
Line Frequency Response	$\pm$ 0.25 dB, 20 Hz to 20 kHz
Phono Gain	35dB, 1 kHz
Phono Frequency Response	RIAA $\pm$ 0.5 dB, 30 Hz to 20 kHz
<b>Record Output</b>	Stereo, Unbalanced, RCA
Maximum Output	+20 dBu, 10 k $\Omega$ load
Output Impedance	200 $\Omega$ , 1%
Output Trim Range	0 dB to -12 dB
S/N	>98 dB re +4 dBu, 20Hz to 20 kHz, 0 dB gain
THD+N	< 0.1%, 20Hz to 20 kHz, +4 dBu, 0 dB gain, 10 k $\Omega$ load
<b>Main Output</b>	Stereo, Balanced, XLR
Mono/Stereo	Selectable
Maximum Output	+26 dBu, 10 k $\Omega$ load per leg
Output Impedance	200 $\Omega$ , 1% per leg
S/N	>92 dB re +4 dBu, 20Hz to 20 kHz, 0 dB gain
THD+N	< 0.1%, 20Hz to 20 kHz, +4 dBu, 10 k $\Omega$ load per leg
<b>Headphone Output</b>	Stereo, Unbalanced, 1/4" and 3.5mm TRS
Maximum Output Power	180 mW into 150 $\Omega$
Output Volume Range	+4.5 dB to off
Frequency Response	23 Hz to 70 kHz, -3 dB points
S/N	>96 dB re +4 dBu, 20Hz to 20 kHz, 4.5 dB gain
THD+N	< 0.02%, 20Hz to 20 kHz, +4 dBu, 150 $\Omega$ load
<b>Master/Cue Meters</b>	Mono, peak detecting
Sensitivity	0 dB indication = 0 dBu (-20 dBFS)
<b>Mic Inputs</b>	Mono, Balanced, XLR
Mic/Line	each Input selectable
Phantom Power	12 V, 681 $\Omega$ per leg, each Input selectable
Overload Indication	5.5 dB before clipping
Mic/Line Maximum Input	+12 dBu / +28 dBu, minimum gain
Mic/Line Input Impedance	637 $\Omega$ / 4 k $\Omega$ per leg
Mic/Line Gain Trim Range	10 dB to 52 dB / -6 dB to 10 dB, typical
Mic/Line Frequency Response	20 Hz (-0.5 dB/-0.5 dB) to 20 kHz (-1.5 dB/-2 dB)
EIN	127 dBu, R <sub>s</sub> = 150 $\Omega$ , g = 55 dB, 20 Hz to 20 kHz
Mic/Line CMRR	-40 dB, max., 1 kHz
<b>TOSLINK and S/PDIF Outputs</b>	Optical and RCA
Sample Rate	48 kHz
Resolution	24-bit
Dynamic Range	104 dB
THD+N	< 0.02%, 20Hz to 20 kHz, -20 dBFS
<b>USB Digital Audio</b>	Stereo In/Out, USB Type B
Sample Rate	48 kHz
Resolution	16-bit
Dynamic Range	94 dB
THD+N	< 0.04%, 20Hz to 20 kHz, +4 dBu

Parameter	Specification
<b>USB Charge Only Port</b>	USB Type A
Output Voltage	+5 VDC max.
Output Current	+500 mA max.
<b>Unit</b>	
Power Supply Requirement	100 to 240 VAC, 50/60 Hz, .24 amp
Conformity	FCC, cCSAus
Construction	All Steel
Unit Size	5.25"H x 19"W x 5.3"D (3U) (13.3 x 48.3 x 13.5 cm)
Unit Weight	7 lb (3.16 kg)
Shipping Size	11" x 23" x 16" (27.9 x 58.4 x 40.6 cm)
Shipping Weight	11 lb (4.99 kg)
<i>Note: 0 dBu=0.775 Vrms</i>	

## System Example

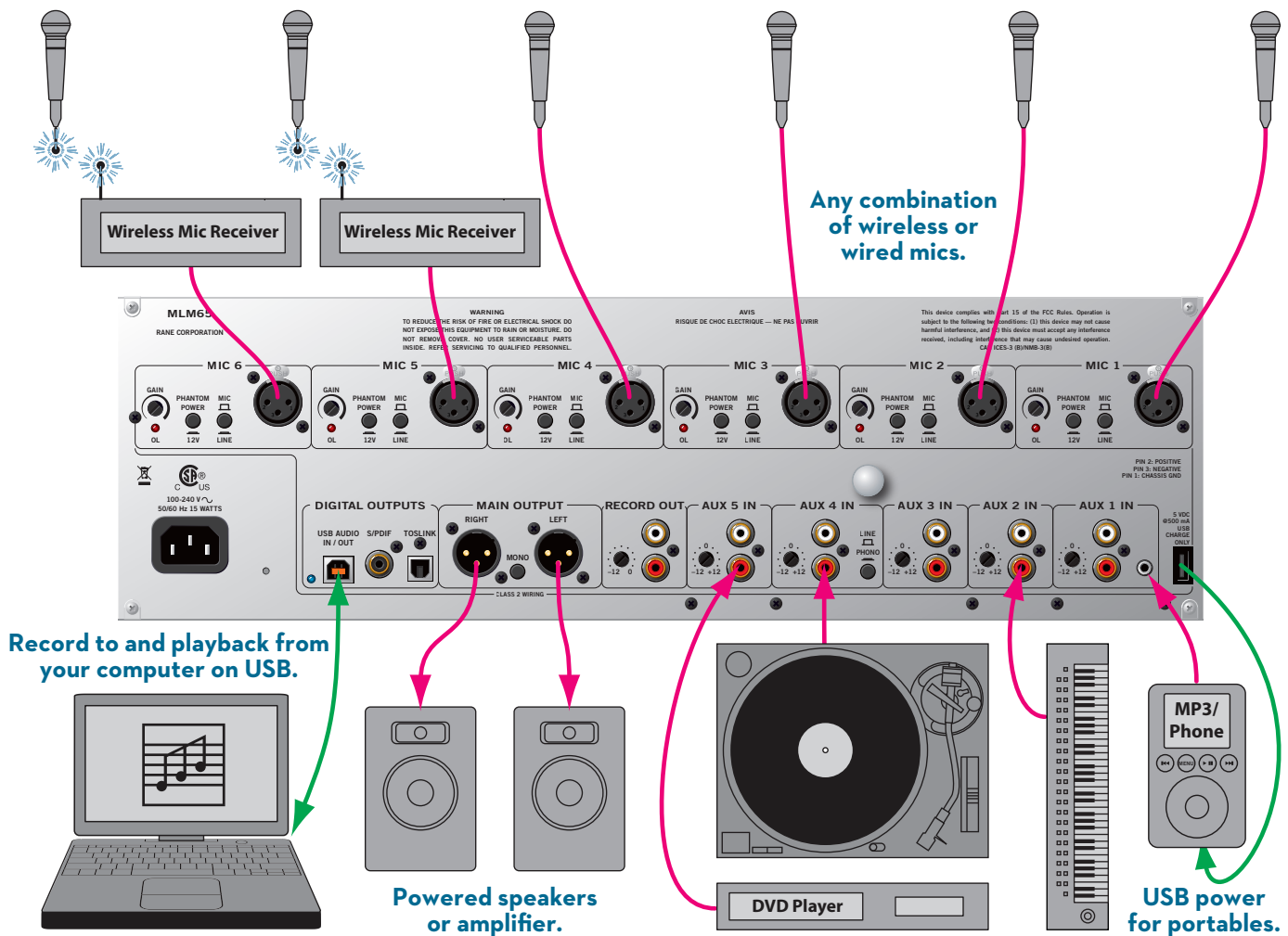

Block Diagram

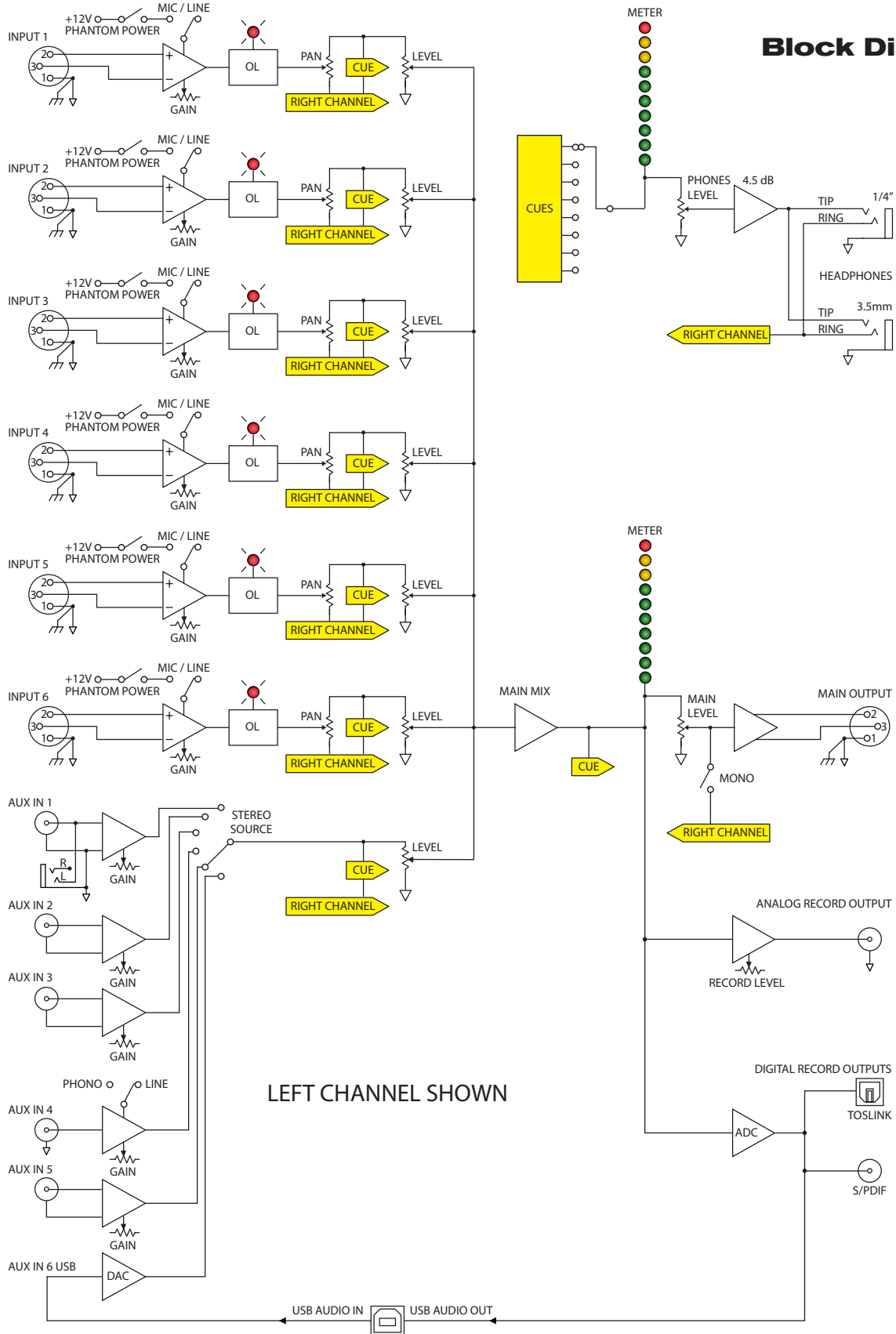

**RANE**

## Sound System Interconnection

- **Cause & prevention of ground loops**
- **Interfacing balanced & unbalanced**
- **Proper pin connections and wiring**
- **Chassis ground vs. signal ground**
- **Ground lift switches**

**Rane Technical Staff**

**RaneNote 110**

© 1985, 1995, 2006, 2007, 2011 Rane Corporation

## Introduction

This note, originally written in 1985, continues to be one of our most useful references. It's popularity stems from the continual and perpetual difficulty of hooking up audio equipment without suffering through all sorts of bizarre noises, hums, buzzes, whistles, etc.— not to mention the extreme financial, physical and psychological price. As technology progresses it is inevitable that electronic equipment and its wiring should be subject to constant improvement. Many things *have* improved in the audio industry since 1985, but unfortunately wiring isn't one of them. However, finally the Audio Engineering Society (AES) has issued a standards document for interconnection of pro audio equipment. It is AES48, titled "*AES48-2005: AES standard on interconnections — Grounding and EMC practices — Shields of connectors in audio equipment containing active circuitry.*"

Rane's policy is to accommodate rather than dictate. However, this document contains suggestions for external wiring changes that should ideally only be implemented by trained technical personnel. Safety regulations require that all original grounding means provided from the factory be left intact for safe operation. No guarantee of responsibility for incidental or consequential damages can be provided. (*In other words, don't modify cables, or try your own version of grounding unless you really understand exactly what type of output and input you have to connect.*)

## Ground Loops

Almost all cases of noise can be traced directly to ground loops, grounding or lack thereof. It is important to understand the mechanism that causes grounding noise in order to effectively eliminate it. Each component of a sound system produces its own ground internally. This ground is usually called the audio *signal* ground. Connecting devices together with the interconnecting cables can tie the signal grounds of the two units together in one place through the conductors in the cable. Ground loops occur when the grounds of the two units are also tied together in another place: via the third wire in the line cord, by tying the metal chassis together through the rack rails, etc. These situations create a circuit through which current may flow in a closed “loop” from one unit’s ground out to a second unit and back to the first. It is not simply the presence of this current that creates the hum—it is when this current flows through a unit’s audio signal ground that creates the hum. In fact, even without a ground loop, a little noise current always flows through every interconnecting cable (i.e., it is impossible to eliminate these currents entirely). The mere presence of this ground loop current is no cause for alarm if your system uses properly implemented and *completely* balanced interconnects, which are excellent at rejecting ground loop and other noise currents. Balanced interconnect was developed to be immune to these noise currents, which can never be entirely eliminated. What makes a ground loop current annoying is when the audio signal is affected. Unfortunately, many manufacturers of balanced audio equipment design the internal grounding system

improperly, thus creating balanced equipment that is not immune to the cabling’s noise currents. This is one reason for the bad reputation sometimes given to balanced interconnect.

A second reason for balanced interconnect’s bad reputation comes from those who think connecting unbalanced equipment into “superior” balanced equipment should improve things. Sorry. Balanced interconnect is not compatible with unbalanced. The small physical nature and short cable runs of completely unbalanced systems (home audio) also contain these ground loop noise currents. However, the currents in unbalanced systems never get large enough to affect the audio to the point where it is a nuisance. Mixing balanced and unbalanced equipment, however, is an entirely different story, since balanced and unbalanced interconnect are truly *not compatible*. The rest of this note shows several recommended implementations for all of these interconnection schemes.

The potential or voltage which pushes these noise currents through the circuit is developed between the independent grounds of the two or more units in the system. The impedance of this circuit is low, and even though the voltage is low, the current is high, thanks to Mr. Ohm, without whose help we wouldn’t have these problems. It would take a very high resolution ohm meter to measure the impedance of the steel chassis or the rack rails. We’re talking thousandths of an ohm. So trying to measure this stuff won’t necessarily help you. We just thought we’d warn you.

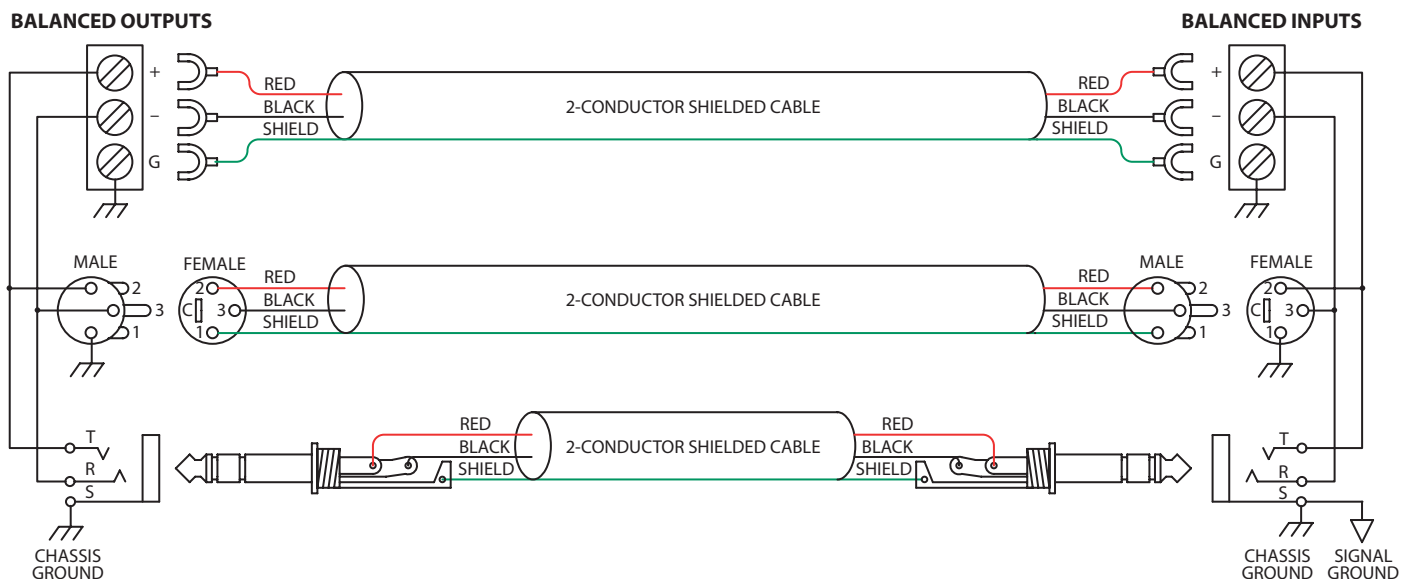

Figure 1a. The right way to do it.

## The Absolute Best Right Way To Do It

The method specified by AES48 is to use balanced lines and *tie the cable shield to the metal chassis (right where it enters the chassis) at both ends of the cable.*

A balanced line requires three separate conductors, two of which are signal (+ and -) and one shield (see Figure 1a). The shield serves to guard the sensitive audio lines from interference. Only by using balanced line interconnects can you *guarantee* (yes, *guarantee*) hum-free results. Always use twisted pair cable. Chassis tying the shield at each end also *guarantees* the best possible protection from RFI [radio frequency interference] and other noises [neon signs, lighting dimmers].

Neil Muncy<sup>1</sup>, an electroacoustic consultant and seasoned veteran of years of successful system design, chairs the AES Standards Committee (SC-05-05) working on this subject. He tirelessly tours the world giving seminars and dispensing information on how to successfully hook-up pro audio equipment<sup>2</sup>. He makes the simple point that it is absurd that you cannot go out and buy pro audio equipment from several different manufacturers, buy standard off-the-shelf cable assemblies, come home, hook it all up and have it work hum and noise free. *Plug and play.* Sadly, almost never is this the case, despite the science and rules of noise-free interconnect known and documented for over 60 years (see References for complete information).

It all boils down to using balanced lines, only balanced lines, and nothing but balanced lines. This is why they were developed. Further, that you *tie the shield to the chassis, at the point it enters the chassis, and at both ends of the cable* (more on 'both ends' later).

Since standard XLR cables come with their shields tied to pin 1 at each end (the shells are not tied, nor need be), this means equipment using 3-pin, XLR-type connectors *must tie pin 1 to the chassis* (usually called chassis ground) — not the audio signal ground as is most common.

### COMMON (WRONG) PRACTICE

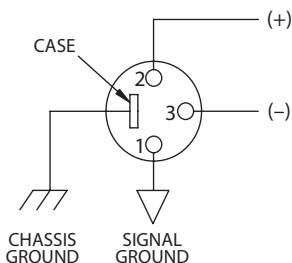

### RECOMMENDED PRACTICE

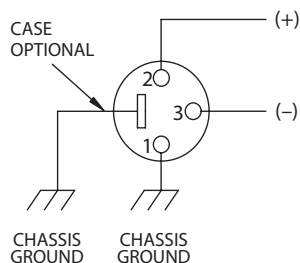

Figure 1b. Recommended practice.

Not using *signal ground* is the most radical departure from common pro-audio practice. Not that there is any argument about its validity. There isn't. **This is the right way to do it.** So why doesn't audio equipment come wired this way? Well, some does, and since 1993, more of it does. That's when Rane started manufacturing some of its products with balanced inputs and outputs tying pin 1 to chassis. So why doesn't everyone do it this way? Because life is messy, some things are hard to change, and there will always be equipment in use that was made before proper grounding practices were in effect.

Unbalanced equipment is another problem: it is everywhere, easily available and inexpensive. All those RCA and 1/4" TS connectors found on consumer equipment; effect-loops and insert-points on consoles; signal processing boxes; semi-pro digital and analog tape recorders; computer cards; mixing consoles; et cetera.

The next several pages give tips on how to successfully address hooking up unbalanced equipment. Unbalanced equipment when "blindly" connected with fully balanced units starts a pattern of hum and undesirable operation, requiring extra measures to correct the situation.

## The Next Best Right Way To Do It

The quickest, quietest and most foolproof method to connect balanced and unbalanced is to **transformer isolate all unbalanced connections.** See Figure 2.

Many manufacturers provide several tools for this task, including Rane. Consult your audio dealer to explore the options available.

The goal of these adaptors is to allow the use of *standard cables.* With these transformer isolation boxes, modification of cable assemblies is unnecessary. Virtually any two pieces of audio equipment can be successfully interfaced without risk of unwanted hum and noise.

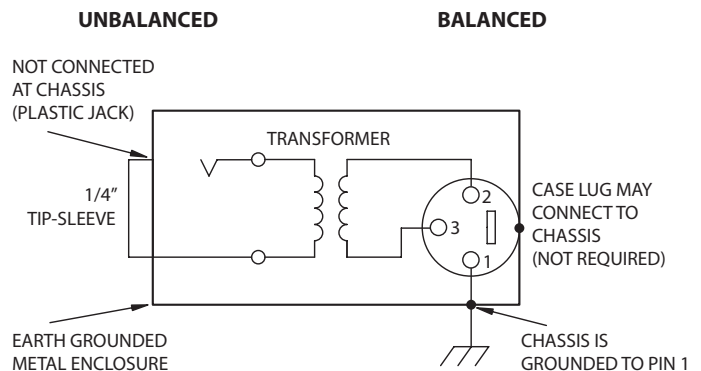

Figure 2. Transformer Isolation

Another way to create the necessary isolation is to use a *direct box*. Originally named for its use to convert the high impedance, high level output of an electric guitar to the low impedance, low level input of a recording console, it allowed the player to plug “directly” into the console. Now this term is commonly used to describe any box used to convert unbalanced lines to balanced lines.

### The Last Best Right Way To Do It

**If transformer isolation is not an option, special cable assemblies are a last resort.** The key here is to prevent the shield currents from flowing into a unit whose grounding scheme creates ground loops (hum) in the audio path (i.e., most audio equipment).

It is true that connecting both ends of the shield is theoretically the best way to interconnect equipment –though this assumes the interconnected equipment is internally grounded properly. Since most equipment is *not* internally grounded properly, connecting both ends of the shield is not often practiced, since doing so usually creates noisy interconnections.

A common solution to these noisy hum and buzz problems involves disconnecting one end of the shield, even though one can not buy off-the-shelf cables with the shield disconnected at one end. The best end to disconnect is the receiving end. If one end of the shield is disconnected, the noisy hum current stops flowing and away goes the hum — but only at low frequencies. A ground-sending-end-only shield connection minimizes the possibility of high frequency (radio) interference since it prevents the shield from acting as an antenna to the next input. Many reduce this potential RF interference by providing an RF path through a small capacitor (0.1 or 0.01 microfarad ceramic disc) connected from the lifted end of the shield to the chassis. (This is referred to as the “hybrid shield termination” where the sending end is bonded to the chassis and the receiving end is capacitively coupled. See Neutrik’s EMC-XLR for example.) The fact that many modern day installers still follow this one-end-only rule with consistent success indicates this and other acceptable solutions to

RF issues exist, though the increasing use of digital and wireless technology greatly increases the possibility of future RF problems.

If you’ve truly isolated your hum problem to a specific unit, chances are, even though the documentation indicates proper chassis grounded shields, the suspect unit is not internally grounded properly. Here is where special test cable assemblies, shown in Figure 3, really come in handy. These assemblies allow you to connect the shield to chassis ground *at the point of entry*, or to pin 1, or to lift one end of the shield. The task becomes more difficult when the unit you’ve isolated has multiple inputs and outputs. On a suspect unit with multiple cables, try various configurations on each connection to find out if special cable assemblies are needed at more than one point.

See Figure 4 for suggested cable assemblies for your particular interconnection needs. Find the appropriate output configuration (down the left side) and then match this with the correct input configuration (across the top of the page.) Then refer to the following pages for a recommended wiring diagram.

### Ground Lifts

Many units come equipped with ground lift switches. In only a few cases can it be shown that a ground lift switch improves ground related noise. (Has a ground lift switch ever *really* worked for you?) In reality, the presence of a ground lift switch greatly reduces a unit’s ability to be “properly” grounded and therefore immune to ground loop hums and buzzes. Ground lifts are simply another Band-Aid<sup>®</sup> to try in case of grounding problems. It is true that an entire system of properly grounded equipment, without ground lift switches, is guaranteed (yes *guaranteed*) to be hum free. The problem is most equipment is *not* (both internally and externally, AC system wise) grounded properly.

Most units with ground lifts are shipped so the unit is “grounded” — meaning the chassis is connected to audio signal ground. (This should be the best and is the “safest” position for a ground lift switch.) If after hooking up your system it exhibits excessive hum or

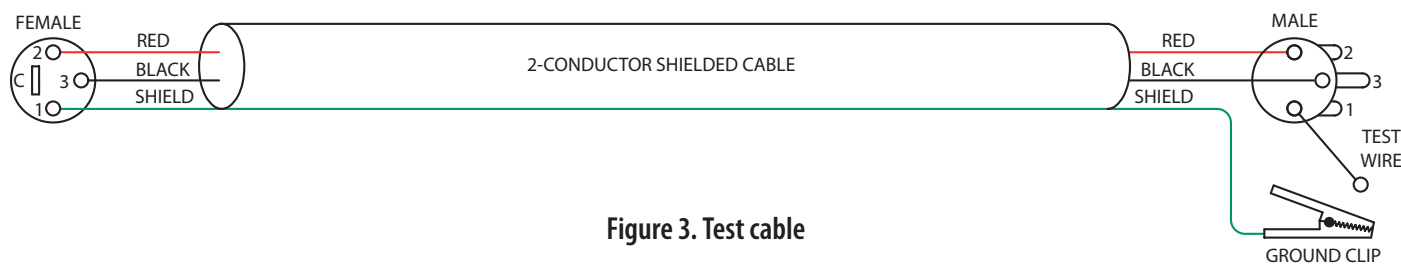

Figure 3. Test cable

buzzing, there is an incompatibility somewhere in the system's grounding configuration. In addition to these special cable assemblies that may help, here are some more things to try:

1. Try combinations of lifting grounds on units supplied with lift switches (or links). It is wise to do this with the power off!
2. If you have an entirely balanced system, verify all chassis are tied to a good earth ground, for safety's sake and hum protection. Completely unbalanced systems never earth ground anything (except cable TV, often a ground loop source). If you have a mixed balanced and unbalanced system, do yourself a favor and use isolation transformers or, if you can't do that, try the special cable assemblies described here and expect it to take many hours to get things quiet. May the Force be with you.
3. Balanced units with outboard power supplies (wall warts or "bumps" in the line cord) do *not* ground the chassis through the line cord. Make sure such units are solidly grounded by tying the chassis to an earth ground using a star washer for a reliable contact. (Rane always provides this chassis point as an external screw with a toothed washer.) Any device with a 3-prong AC plug, such as an amplifier, may serve as an earth ground point. Rack rails may or may not serve this purpose depending on screw locations and paint jobs.

### Floating, Pseudo, and Quasi-Balancing

During inspection, you may run across a ¼" output called floating unbalanced, sometimes also called pseudo-balanced or quasi-balanced. In this configuration, the sleeve of the output stage is not connected inside the unit and the ring is connected (usually through a small resistor) to the audio signal ground. This allows the tip and ring to "appear" as an equal impedance, not-quite balanced output stage, even though the output circuitry is unbalanced.

Floating unbalanced often works to drive either a balanced or unbalanced input, depending if a TS or TRS standard cable is plugged into it. When it hums, a special cable is required. See drawings #11 and #12, and do not make the cross-coupled modification of tying the ring and sleeve together.

### Winning the Wiring Wars

- Use balanced connections whenever possible, with the shield bonded to the metal chassis at both ends.
- Transformer isolate all unbalanced connections from balanced connections.
- Use special cable assemblies when unbalanced lines cannot be transformer isolated.
- Any unbalanced cable must be kept under 10 feet (3 m) in length. Lengths longer than this will amplify all the nasty side effects of unbalanced circuitry's ground loops.

### Summary

If you are unable to do things correctly (i.e. use fully balanced wiring with shields tied to the *chassis* at both ends, or transformer isolate all unbalanced signals from balanced signals) then there is no guarantee that a hum-free interconnect can be achieved, nor is there a definite scheme that will assure noise-free operation in all configurations.

### References

1. Neil A. Muncy, "Noise Susceptibility in Analog and Digital Signal Processing Systems," presented at the 97th AES Convention of Audio Engineering Society in San Francisco, CA, Nov. 1994.
2. *Grounding, Shielding, and Interconnections in Analog & Digital Signal Processing Systems: Understanding the Basics*; Workshops designed and presented by Neil Muncy and Cal Perkins, at the 97th AES Convention of Audio Engineering Society in San Francisco, CA, Nov. 1994.
3. The entire June 1995 AES Journal, Vol. 43, No. 6, available \$6 members, \$11 nonmembers from the Audio Engineering Society, 60 E. 42nd St., New York, NY, 10165-2520.
4. Phillip Giddings, *Audio System Design and Installation* (SAMS, Indiana, 1990).
5. Ralph Morrison, *Noise and Other Interfering Signals* (Wiley, New York, 1992).
6. Henry W. Ott, *Noise Reduction Techniques in Electronic Systems*, 2nd Edition (Wiley, New York, 1988).
7. Cal Perkins, "Measurement Techniques for Debugging Electronic Systems and Their Instrumentation," *The Proceedings of the 11th International AES Conference: Audio Test & Measurement*, Portland, OR, May 1992, pp. 82-92 (Audio Engineering Society, New York, 1992).
8. Macatee, *RaneNote*: "Grounding and Shielding Audio Devices," Rane Corporation, 1994.
9. Philip Giddings, "Grounding and Shielding for Sound and Video," *S&VC*, Sept. 20th, 1995.
10. AES48-2005: *AES standard on interconnections — Grounding and EMC practices — Shields of connectors in audio equipment containing active circuitry* (Audio Engineering Society, New York, 2005).

*Band-Aid* is a registered trademark of Johnson & Johnson

# To Input





From Output	CABLE CONNECTORS						
		MALE BALANCED XLR	1/4" BALANCED TRS (TIP-RING-SLEEVE)	1/4" OR 3.5mm UNBALANCED TS (TIP-SLEEVE)	UNBALANCED RCA	BALANCED EUROBLOCK	
			<b>1</b>	<b>2</b>	<b>3<sub>B</sub></b>	<b>4<sub>B</sub></b>	+ to + - to - SHIELD NC
			<b>1</b>	<b>2</b>	<b>5</b>	<b>6</b>	+ to + - to - SHIELD NC
			<b>7</b>	<b>8</b>	<b>9<sub>B</sub></b>	<b>10<sub>B</sub></b>	+ to + - to - SHIELD ONLY TO EUROBLOCK
			<b>7</b>	<b>8</b>	<b>11</b>	<b>12</b>	+ to + - to - SHIELD NC
			<b>21<sub>A</sub></b>	<b>22<sub>A</sub></b>	<b>11</b>	<b>12</b>	+ to + - to - GROUND to GROUND
			<b>13</b>	<b>14</b>	<b>15<sub>A</sub></b>	<b>16<sub>A</sub></b>	<b>23</b>
			<b>17</b>	<b>18</b>	<b>19<sub>A</sub></b>	<b>20<sub>A</sub></b>	<b>23</b>
			+ to + - to - SHIELD ONLY TO XLR PIN 1	+ to + - to - SHIELD ONLY TO TRS SLEEVE	<b>24</b>	<b>24</b>	+ to + - to - GROUND to GROUND

Figure 4. Interconnect chart for locating correct cable assemblies on the following pages.

Note: (A) This configuration uses an "off-the-shelf" cable.

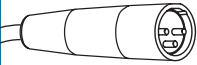
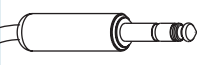
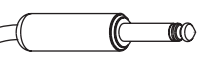
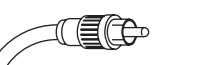
Note: (B) This configuration causes a 6 dB signal loss. Compensate by "turning the system up" 6 dB.

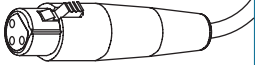
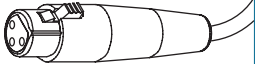
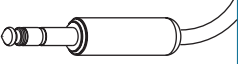
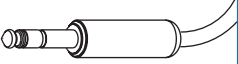
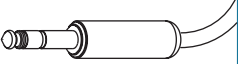
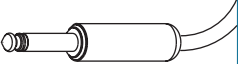
From Output

To Input

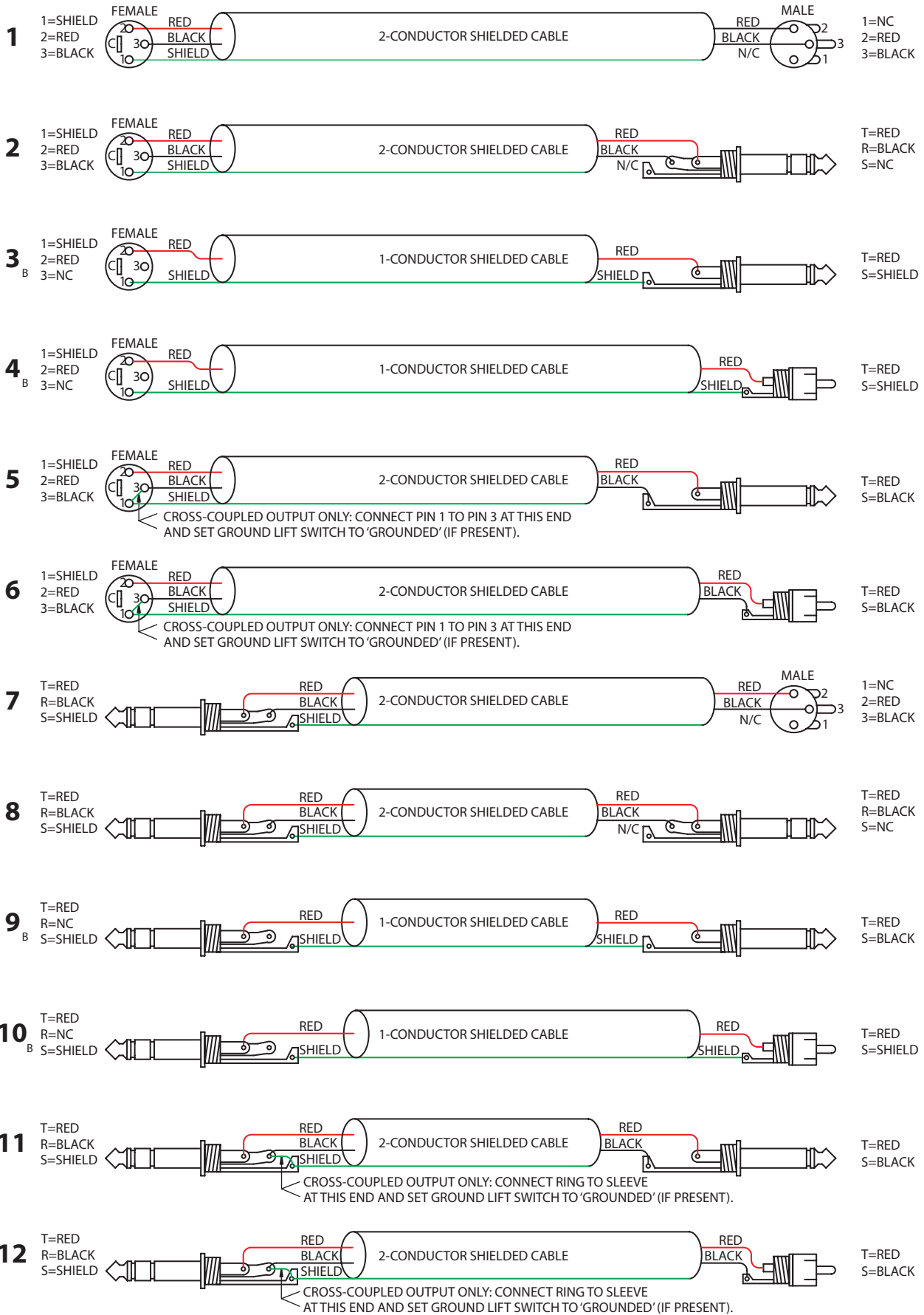

From Output

To Input

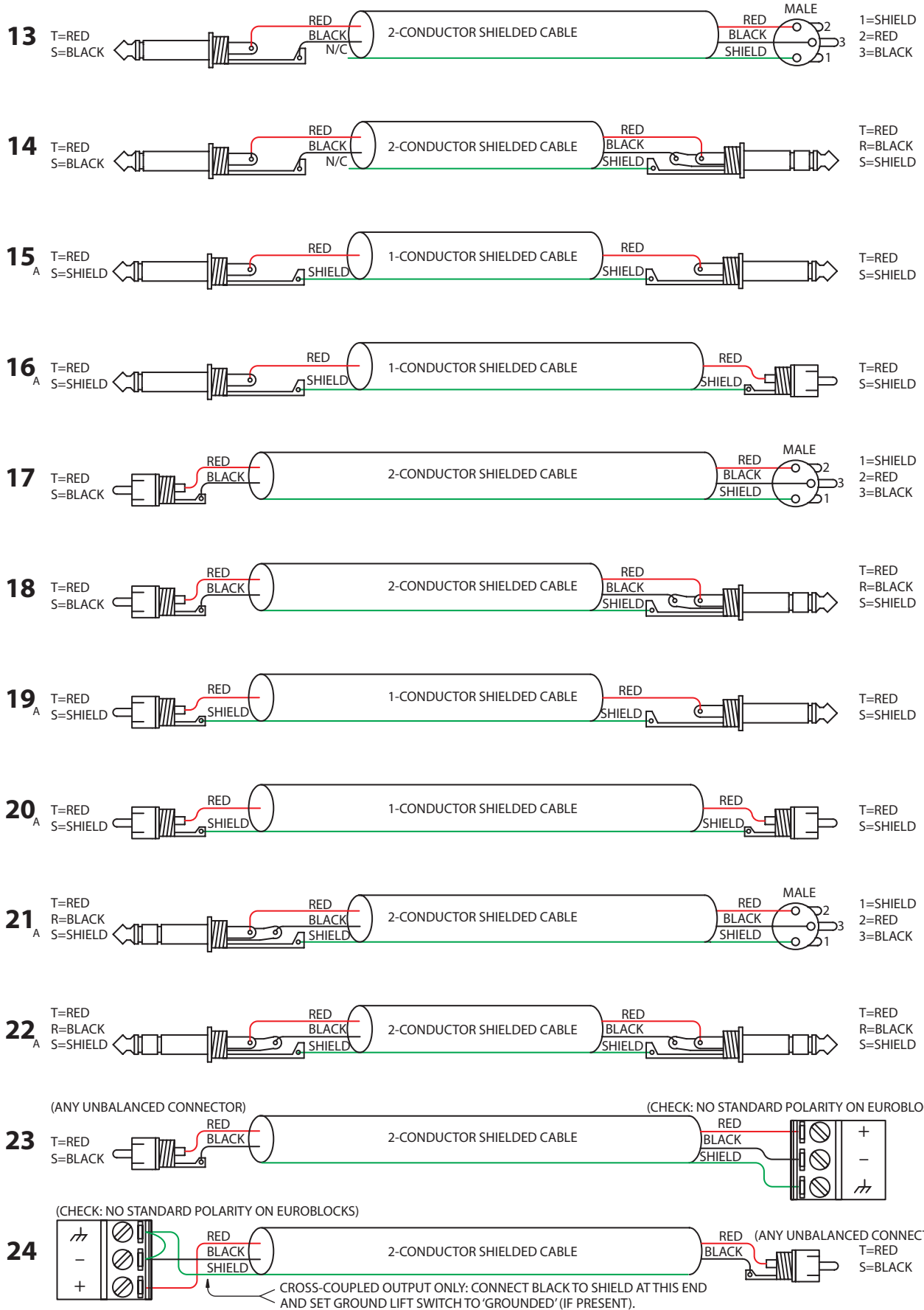

**RANE**



## FACTORY AUTHORIZED SERVICE

Your unit may be serviced by the Rane Factory or any Authorized Rane Service Center. To find a Service Center near you, please call the Rane factory, or check the Rane website. Please do not return your unit to Rane without prior authorization.

Rane Corporation

To obtain service or a Return Authorization, please phone 425-355-6000

or Fax 425-347-7757

The current list of U.S. Rane Authorized Service Centers is found on our website: [www.rane.com/service.html](http://www.rane.com/service.html)

## LIMITED DOMESTIC WARRANTY

RANE CORPORATION WARRANTS ALL RANE PRODUCTS (EXCEPT THOSE ITEMS CLASSIFIED AS *WEAR PARTS*, AND LISTED ON THE MANUAL-1 PAGE OF EACH OPERATORS MANUAL) PURCHASED IN THE USA AGAINST DEFECTS IN MATERIAL OR WORKMANSHIP FOR A PERIOD OF TWO (2) YEARS. *WEAR PARTS* ARE LIMITED TO A PERIOD OF NINETY (90) DAYS FROM THE INITIAL DATE OF RETAIL PURCHASE FROM AN AUTHORIZED RANE DEALER—*WEAR PARTS* REQUIRE PROOF OF PURCHASE DATE. This limited warranty extends to all purchasers or owners of the product during the warranty period beginning with the original retail purchase. Rane Corporation does not, however, warrant its products against any and all defects: 1) arising out of material or workmanship not provided or furnished by Rane, or 2) resulting from abnormal use of the product or use in violation of instructions, or 3) in products repaired or serviced by other than authorized Rane repair facilities, or 4) in products with removed or defaced serial numbers, or 5) in components or parts or products expressly warranted by another manufacturer. Rane agrees to supply all parts and labor to repair or replace defects covered by this limited warranty with parts or products of original or improved design, at its option in each respect, if the defective product is shipped prior to the end of the warranty period to any Rane authorized warranty repair facility in the U.S. or to the Rane factory in the original packaging or a replacement supplied by Rane, with all transportation costs and full insurance paid each way by the purchaser or owner.

### LIMITED WARRANTY OUTSIDE THE U.S.A.

RANE PRODUCTS ARE WARRANTED ONLY IN THE COUNTRY WHERE PURCHASED, THROUGH THE AUTHORIZED RANE DISTRIBUTOR IN THAT COUNTRY, AGAINST DEFECTS IN MATERIAL OR WORKMANSHIP, THE SPECIFIC PERIOD OF THIS LIMITED WARRANTY SHALL BE THAT WHICH IS DESCRIBED TO THE ORIGINAL RETAIL PURCHASER BY THE AUTHORIZED RANE DEALER OR DISTRIBUTOR AT THE TIME OF PURCHASE. Rane Corporation does not, however, warrant its products against any and all defects: 1) arising out of materials or workmanship not provided or furnished by Rane, or 2) resulting from abnormal use of the product or use in violation of instructions, or 3) in products repaired or serviced by other than authorized Rane repair facilities, or 4) in products with removed or defaced serial numbers, or 5) in components or parts or products expressly warranted by another manufacturer. Rane agrees, through the applicable authorized distributor, to repair or replace defects covered by this limited warranty with parts or products of original or improved design, at its option in each respect, if the defective product is shipped prior to the end of the warranty period to the designated authorized Rane warranty repair facility in the country where purchased, or to the Rane factory in the U.S., in the original packaging or a replacement supplied by Rane, with all transportation costs and full insurance paid each way by the purchaser or owner.

ALL REMEDIES AND THE MEASURE OF DAMAGES ARE LIMITED TO THE ABOVE SERVICES, IT IS POSSIBLE THAT ECONOMIC LOSS OR INJURY TO PERSON OR PROPERTY MAY RESULT FROM THE FAILURE OF THE PRODUCT; HOWEVER, EVEN IF RANE HAS BEEN ADVISED OF THIS POSSIBILITY, THIS LIMITED WARRANTY DOES NOT COVER ANY SUCH CONSEQUENTIAL OR INCIDENTAL DAMAGES. SOME STATES OR COUNTRIES DO NOT ALLOW THE LIMITATIONS OR EXCLUSION OF INCIDENTAL OR CONSEQUENTIAL DAMAGES, SO THE ABOVE LIMITATION MAY NOT APPLY TO YOU.

ANY AND ALL WARRANTIES, EXPRESS OR IMPLIED, ARISING BY LAW, COURSE OF DEALING, COURSE OF PERFORMANCE, USAGE OF TRADE, OR OTHERWISE, INCLUDING BUT NOT LIMITED TO IMPLIED WARRANTIES OF MERCHANTABILITY AND FITNESS FOR A PARTICULAR PURPOSE, ARE LIMITED TO A PERIOD OF TWO (2) YEARS FROM EITHER THE DATE OF ORIGINAL RETAIL PURCHASE OR, IN THE EVENT NO PROOF OF PURCHASE DATE IS AVAILABLE, THE DATE OF MANUFACTURE, SOME STATES OR COUNTRIES DO NOT ALLOW LIMITATIONS ON HOW LONG AN IMPLIED WARRANTY LASTS, SO THE ABOVE LIMITATIONS MAY NOT APPLY TO YOU. THIS LIMITED WARRANTY GIVES YOU SPECIFIC LEGAL RIGHTS, AND YOU MAY ALSO HAVE OTHER RIGHTS WHICH VARY FROM STATE TO STATE, COUNTRY TO COUNTRY.

## WARRANTY PROCEDURE - Only Valid in the USA

NOTICE! You must complete and return the warranty card or register your product online to extend the Warranty from 2 years to 3 years!

TO VALIDATE YOUR EXTENDED WARRANTY: Use the postcard that came in the box with your unit, or go to [www.rane.com](http://www.rane.com) and click on **New Product Registration**. Fill out the warranty completely, being sure to **include the model and serial number** of the unit since this is how warranties are tracked. If your Rane product was purchased in the USA, mail the completed card or register online with to Rane Corporation within 10 days from the date of purchase. **If you purchased the product outside the USA you must file your warranty registration with the Rane Distributor in that country.** It is advised that you keep your bill of sale as proof of purchase, should any difficulties arise concerning the registration of the warranty card. **NOTICE: IT IS NOT NECESSARY TO REGISTER IN ORDER TO RECEIVE RANE CORPORATION'S STANDARD TWO YEAR LIMITED WARRANTY.**

WARRANTY REGISTRATION is made and tracked by **model and serial numbers only**, not by the purchaser's or owner's name. Therefore any warranty correspondence or inquires **must** include the model and serial number of the product in question. Be sure to fill in the model and serial number in the space provided below and keep this in a safe place for future reference.

WARRANTY SERVICE MUST BE PERFORMED ONLY BY AN AUTHORIZED RANE SERVICE FACILITY LOCATED IN THE COUNTRY WHERE THE UNIT WAS PURCHASED, OR (if product was purchased in the USA) AT THE RANE FACTORY IN THE USA. If the product is being sent to Rane for repair, please call the factory for a Return Authorization number. We recommend advance notice be given to the repair facility to avoid possible needless shipment in case the problem can be solved over the phone. **UNAUTHORIZED SERVICE PERFORMED ON ANY RANE PRODUCT WILL VOID ITS EXISTING FACTORY WARRANTY.**

### FACTORY SERVICE

If you wish your Rane product to be serviced at the factory, **it must be shipped fully insured, in the original packing box or equivalent.** This warranty will **not** cover repairs on products damaged through improper packaging. If possible, avoid sending products through the mail. Be sure to include in the package:

1. Complete return street shipping address (P.O. Box numbers are **not** acceptable).
2. A detailed description of any problems experienced, including the make and model numbers of any other system equipment.
3. Remote power supply, if applicable.

Repaired products purchased in the U.S. will be returned prepaid freight via the same method they were sent to Rane. Products purchased in the USA, but sent to the factory from outside the USA **must** include return freight funds, and the sender is fully responsible for all customs procedures, duties, tariffs and deposits.

In order to qualify for Rane's one year extended warranty (for a total of 3 years parts and labor), the warranty must be completely filled out and sent to us immediately. Valid in USA only.

**We recommend you write your serial number here in your owners manual and on your sales receipt for your records.**

SERIAL NUMBER: \_\_\_\_\_ PURCHASE DATE: \_\_\_\_\_

# Declaration of Conformity

## Application of Council Directive(s):

2002/96/EC  
2004/108/EC  
2011/65/EU

## Standard(s) to which conformity is declared:

EN60065: 2002/A1:2006/A11:2008  
EN55103-1:2009  
EN55103-2:2009  
EN50581:2012  
ENVIRONMENT E2  
Serial Numbers 900000-999999

## Manufacturer:

Rane Corporation  
10802 47th Avenue West  
Mukilteo WA 98275-5000 USA

This equipment has been tested and found to be in compliance with all applicable standards and regulations applying to the Electromagnetic Compatibility (EMC) directive 2004/108/EC. In order for the customer to maintain compliance with this regulation, high quality shielded cable must be used for interconnection to other equipment. Modification of the equipment, other than that expressly outlined by the manufacturer, is not allowed under this directive. The user of this equipment shall accept full responsibility for compliance with the EMC directive in the event that the equipment is modified without written consent of the manufacturer. This declaration of conformity is issued under the sole responsibility of Rane Corporation.

## Type of Equipment: Professional Audio Signal Processing

**Brand:** Rane

**Model:** MLM 65

## Immunity Results:

### Test Description

#### RF Electromagnetic Fields Immunity

80 MHz - 1000 MHz, 1 kHz AM, 80% depth, 3V/m

THD+N: 4 dBu, 400 Hz, BW = 20 Hz - 20 kHz

### Measurement

### Conditions

<-80 dB

80 MHz - 370 MHz

<-64 dB

370 MHz - 660 MHz

<-79 dB

660 MHz - 1000 MHz

#### Conducted RF Disturbances Immunity

150 kHz - 80 MHz, 1 kHz AM, 80% depth, 3V rms

<-70 dB

150 kHz - 3.27 MHz

<-44 dB

3.27 MHz - 12.6 MHz

<-59 dB

12.6 MHz - 31.7 MHz

<-70 dB

31.7 MHz - 80 MHz

#### Magnetic Fields Immunity

50 Hz - 10 kHz, 3.0 - 0.3 A/m

<-80 dB

#### Common Mode Immunity (Signal Ports)

50 Hz - 10 kHz, -20 dBu

<-96 dB

Bandpass re: 4 dBu, 1/3-octave

*I, the undersigned, hereby declare that the equipment specified above conforms to the Directive(s) and Standard(s) shown above.*

  
\_\_\_\_\_  
(Signature)

**Greg Frederick**

(Full Name)

**Compliance Engineer**

(Position)

**March 1, 2010**

(Date)

**Mukilteo WA USA**

(Place)

# MLM65

RANE CORPORATION

**WARNING**  
TO REDUCE THE RISK OF FIRE OR ELECTRICAL SHOCK DO NOT EXPOSE THIS EQUIPMENT TO RAIN OR MOISTURE. DO NOT REMOVE COVER. NO USER SERVICEABLE PARTS INSIDE. REFER SERVICING TO QUALIFIED PERSONNEL.

AVIS  
RISQUE DE CHOC ELECTRIQUE — NE PAS OUVRIR

This device complies with Part 15 of the FCC Rules. Operation is subject to the following two conditions: (1) this device may not cause harmful interference, and (2) this device must accept any interference received, including interference that may cause undesired operation.  
CAN ICES-3 (B)/NMB-3(B)

The rear panel features six microphone inputs (MIC 1-6) and five auxiliary inputs (AUX 1-5). Each MIC input includes a gain knob, phantom power switch, and MIC/LINE selector. Each AUX input includes a gain knob and -12V/+12V selector. The panel also includes a RECORD OUT section with LINE and PHONO inputs, a MAIN OUTPUT section with LEFT and RIGHT channels, and a DIGITAL OUTPUTS section with USB AUDIO S/PDIF IN/OUT and TOSLINK ports. A 5VDC @500mA USB CHARGE ONLY port is located at the top right. A power jack is at the bottom left, with specifications: 100-240 V<sub>~</sub> 50/60 Hz 15 WATTS. A CLASS 2 WIRING label is positioned near the main outputs.

# MLM65

## MIC & LINE MIXER

