

front panel

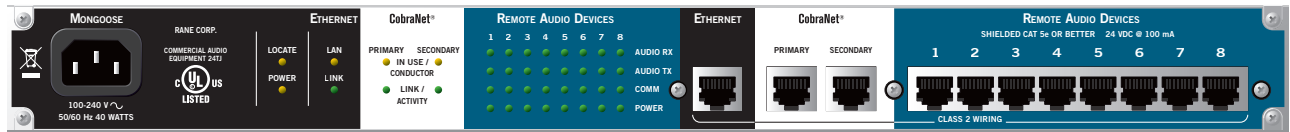

rear panel

General Description

The Mongoose and its Tracker software work with Rane’s Remotes Audio Devices (RADs) and your CobraNet network to deliver digital audio to the “last mile” of installations – between the equipment room/rack and remote spaces. OK, it’s not a mile, we lied: it’s actually 150 meters (492 feet to those in Liberia, Myanmar and the USA).

The Mongoose’s 32-by-32 digital audio matrix router receives its first 16 audio channels from up to eight RADs via the eight rear panel 8P8C (RJ-45) Remote Audio Device ports. The second 16 matrix input channels come from two eight-channel CobraNet receive (Rx) Bundles via standard CobraNet Primary and Secondary/backup ports. The 32 matrix router outputs transmit 16 channels to eight RADs and 16 more channels to two CobraNet transmit (Tx) Bundles.

A family of RAD models is shown to the right. Each converts analog audio to or from 24-bit, 48 kHz digital audio. Each RAD mounts in a standard US electrical gang box (except the RAD16, AM1 and AM2), typically scattered throughout a facility. Shielded CAT 5e cable and termination transport four digital audio channels – two channels in each direction – as well as power, ground and a communications channel via Rane’s proprietary RAD Network.

RAD NETWORK SHIELDED CAT 5e CABLE CONTENTS

- Data communications (COMM)
- 2 digital audio channels (Rx)
- 2 digital audio channels (Tx)
- Power: 24 VDC & ground
- Shield

Mongoose’s rear panel Ethernet port provides for direct or network connection to a computer running Rane’s Mongoose Tracker software. Inexpert users are assured easy network communications with Zeroconf (Link-local/mDNS) and DHCP support. Gone are the days of installers requiring intricate IP knowledge. Yet, facility network managers can configure Mongoose like any other IP network device. The Ethernet port also supports Auto MDI/MDIX which automatically detects and permits either an Ethernet crossover cable (included) or a standard Ethernet cable to be used when directly connecting to a computer.

Features

- 32 by 32 digital audio matrix router.
- Receive 2 and transmit 2 CobraNet Bundles.
- Supports up to 32 digital audio channels from up to 8 RADs.
- Ethernet port supports DHCP, Zeroconf (Link-local & mDNS) & Auto MDI/MDIX.
- Mongoose Tracker setup software for PC is included.
 - Zeroconf-based Discovery automatically finds devices without IP setup or special IP knowledge.
 - Name each Mongoose, RAD and audio channel.

RAD Remote Audio Devices

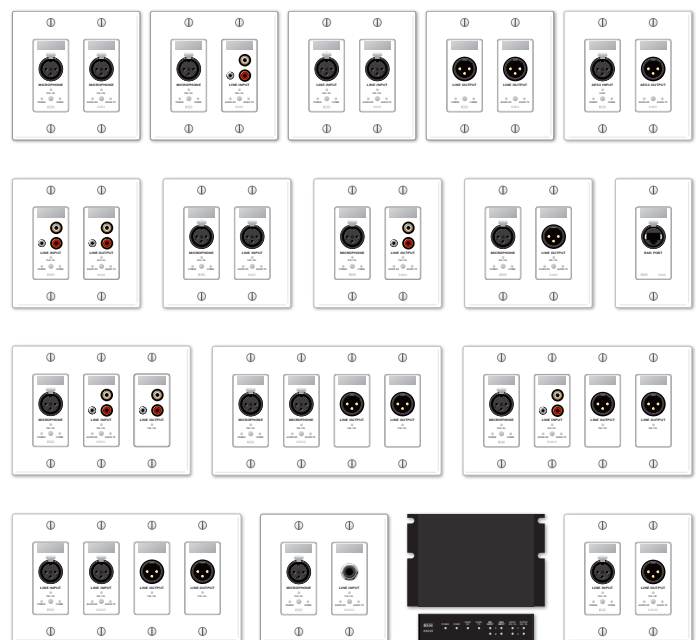

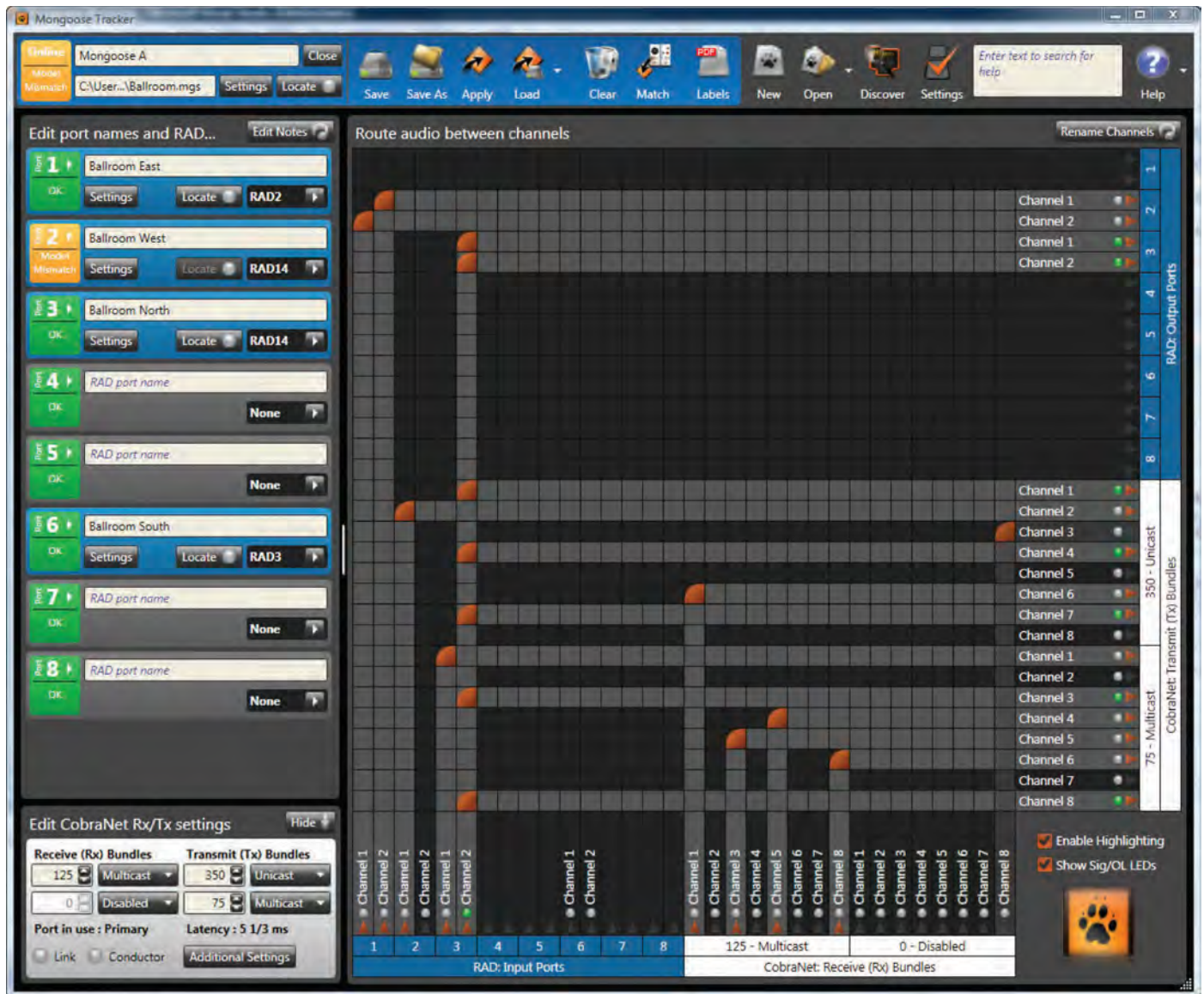

Mongoose Tracker Software

Using the Mongoose Tracker, you configure each Mongoose RAD port with the RAD model that connects to it. You also configure various settings for each RAD, for the Mongoose itself, and for the CobraNet network. One of the key configuration tasks is to set up the audio routing for your Mongoose system. You do this using the audio routing matrix that appears in the Mongoose Tracker's main window. Simply click a crosspoint to attach input port to output, between RADs and CobraNet Channels. You can send the signal to one or more of the following:

- Another RAD connected to the same Mongoose
- Another RAD connected to a different Mongoose
- Another CobraNet-enabled device (e.g., a DSP device).

In addition to configuring the Mongoose components and the audio routing, the software is a valuable tool for troubleshooting any issues that may arise. Although you can determine a lot from the hardware status indicators, the software provides more detail, allowing you to drill down and pinpoint the problem with greater accuracy.

Mongoose Tracker requires a computer running Microsoft Windows® XP (Service Pack 2 or 3) or any version of Vista, 7 or 8 (including 64-bit) with an Ethernet port.



Configurations

Basic RAD to RAD

Analog runs are replaced with digital runs. This is suitable for point-to-point (tie lines), splitter, or mic preamp to line output in an easily configurable “set-&-forget” matrix.

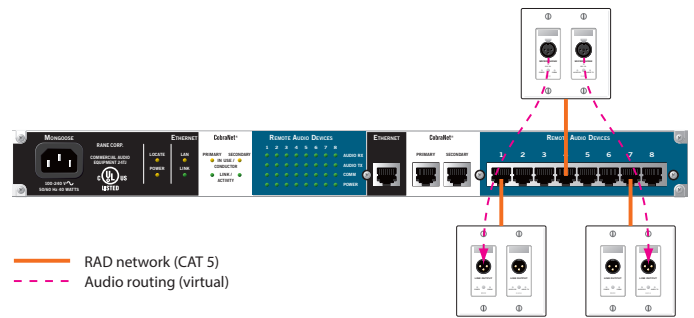
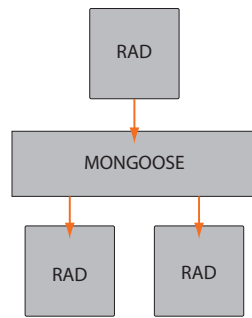

RAD to RAD (made bigger)

RAD network cable distance maximum is 150 meters, so use this configuration when more than eight RADs are needed, or if the RADs are more than 150 meters apart (add a second Mongoose on the network to increase the total distance between RADs).

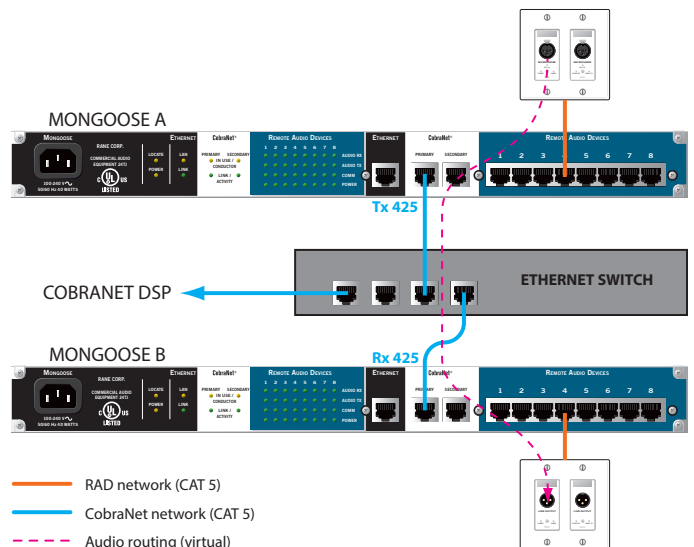
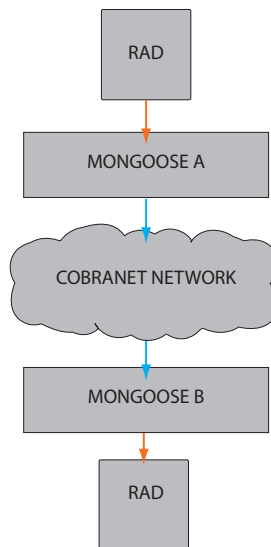

RAD to and from CobraNet DSP

The Mongoose is directly connected to any CobraNet device port.

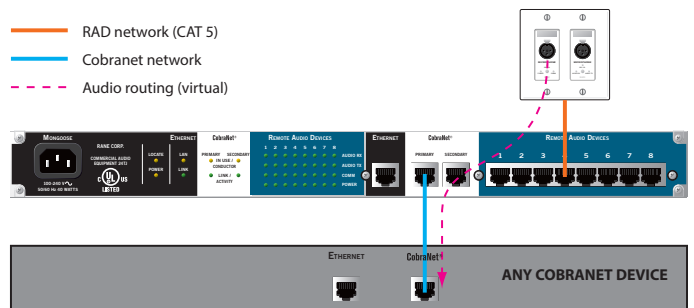
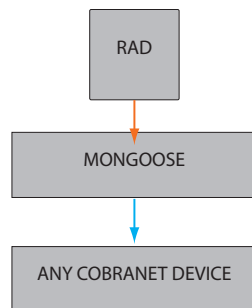

RAD to and from CobraNet DSP (made bigger)

The Mongoose is connected to the CobraNet device through the network. Audio may travel in either or both directions depending on RAD choices.

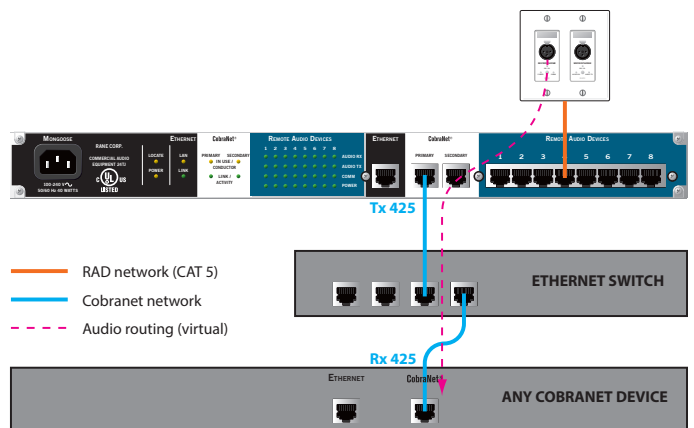
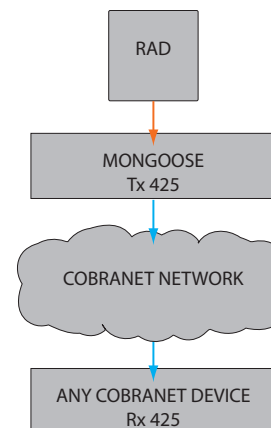

Cafetorium System Example

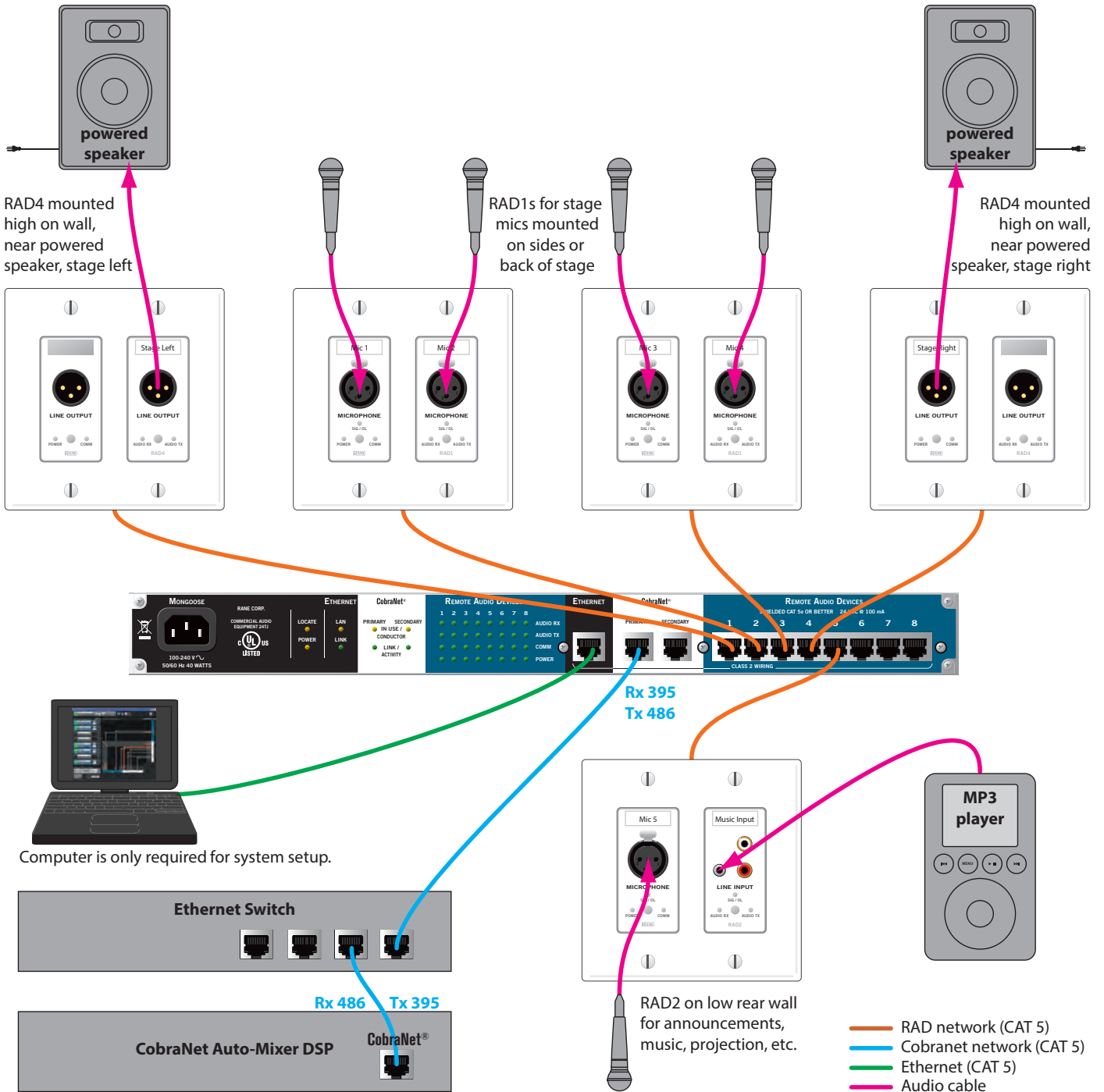

In this example, the Mongoose is a wise choice because it provides the school with tremendous flexibility and extensibility. While delivering superb sound quality in the cafetorium, it also ties in with the existing school paging system, and provides the possibility of additional functionality in the future (as new RADs are introduced).

- Two RAD1s are installed at the stage front for four mics.
- Two RAD4s are installed high on the wall near the speakers. Two to four powered speakers could be accommodated.
- A RAD2 satisfies the need for a microphone and line input (for playing background music) at the back of the room.
- The Mongoose is housed in a sound equipment room along with a network switch and a CobraNet DSP box that contains a microphone auto-mixer.

Hotel System Example

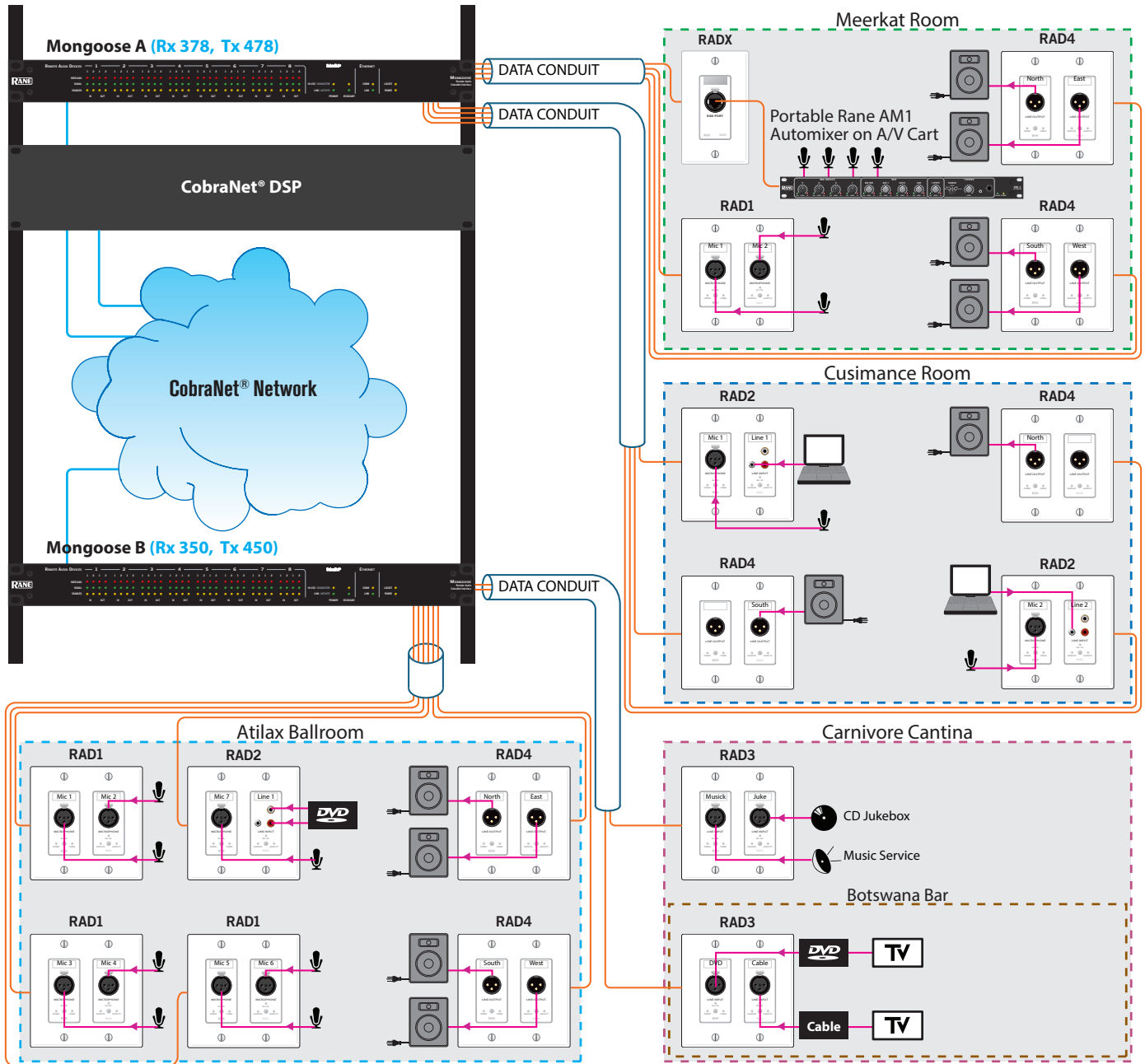

This hotel contains several meeting rooms, a ballroom, and a restaurant/bar. It is a prime target for the Mongoose because of the low channel count in each room and the scattered locations of each audio input and output. This system requires more than eight RADs and, therefore, requires more than one Mongoose.

These examples and more are described in greater detail in the Mongoose Design Manual, downloadable at www.rane.com/mongoose. There you can download the Mongoose Installation Manual, example Tracker Configuration files, DWG and JPG files of the Mongoose and RADs, and the latest software.

rane.com/mongoose

Mongoose Features & Specifications

Parameter	Specification	Limit	Units	Conditions/Comments
Audio Converters	24-bit			Delta Sigma
Audio Processing	24-bit			48 kHz sample rate
Communications Interface				
Ethernet	100BaseTx			100 mega bit/sec; RJ-45 connector
Max cable length: RADs	492 feet / 150 meters			Mongoose to each RAD
Max cable length: CobraNet	328 feet / 100 meters			Standard Ethernet CAT 5 cable length limits
Max cable length: EtherNet	328 feet / 100 meters			Standard Ethernet CAT 5 cable length limits
Wiring	Class 2			All rear panel connections
Unit: Power Requirement	100 to 240	±10%	VAC	50/60 Hz, 1.25 to 0.9 Amp
.....Conformity	FCC, cULus			
.....Size	1.75"H x 19"W x 8.25"D		1U	(4.4 cm x 48.3 cm x 20.9 cm)
.....Weight:	5 lb			(2.3 kg)
Shipping: Size	4.5" x 20.3" x 13.75"			(11.5 cm x 52 cm x 35 cm)
.....Weight:	8 lb			(3.6 kg)

Latency

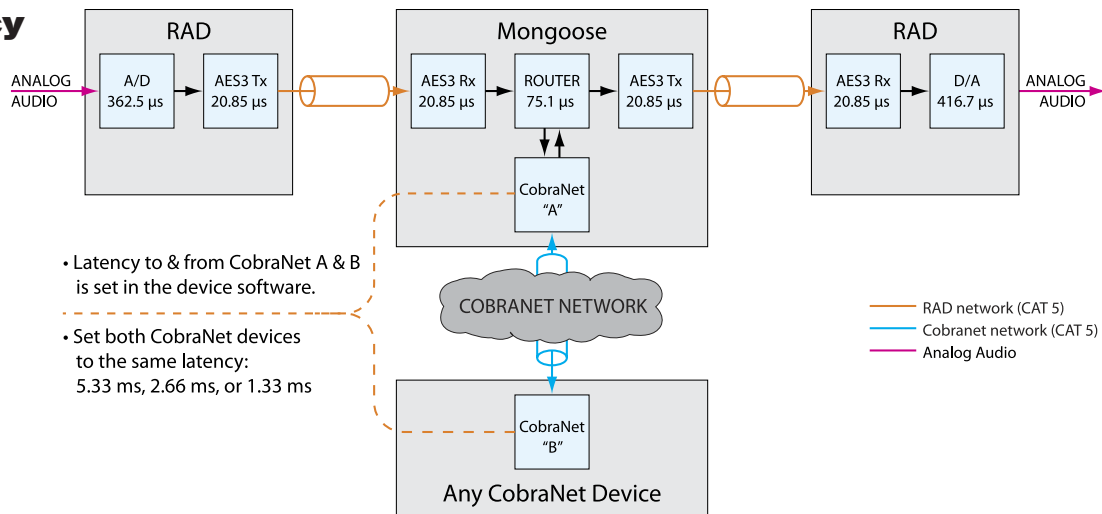

RAD Specifications (all models)

Parameter	Specification	Limit	Units	Conditions/Comments
Cable Length	500 feet / 153 meters			Shielded CAT 5e or better.
Signal Indicator	-50	typ.	dBFS	Unbalanced / Balanced Output, Green LED, Peak-Reading
Overload Indicators	-0.5	typ.	dBFS	Unbalanced / Balanced Output, Red LED, Peak-Reading
Unit: Conformity	CE, FCC			The RAD16 and RAD24 also conform to cULus

RAD1, 2, 3, 4, 5, 6, 7, 8, 9, 11, 12, 14, 15, 18, 23 Features & Specifications

Parameter	Specification	Limit	Units	Conditions/Comments
Mic Input Specs (Both XLR & Euro RADs)				
Input Impedance	2.16 k	1%	Ω	Balanced 1.08 k + 1.08 k
Max. Input Level	-17	min.	dBu	Balanced, Gain = 26 dB, <1% THD
Equivalent Input Noise	-121	typ.	dBu	20 kHz BW, Rs = 150 Ω, Gain = 26 dB
Dynamic Range	98	typ.	dB	re: 0 dBFS, 20 kHz BW, A-weighted, Gain = 26 dB
CMRR	-70	typ.	dB	Rs = 150 Ω, 1 kHz, Gain = 26 dB
Frequency Response	30 to 20k	typ.	Hz	+0, -3dB, At All Gain Settings
THD+Noise	0.010% typ.		@ 1 kHz, 20 kHz BW, Rs = 150 Ω, Output = -6 dBFS, Gain = 26 dB	
Gain Range	26 to 60	typ.	dB	In 1 dB Steps
Phantom Power	+24	4%	V	15 mA Max.
Impedance	1.21 k	1%	Ω	Each Leg
Balanced Line-Level Output Specs (Active Balanced)				
Output Impedance	600	1%	Ω	Each Leg
Max. Output Level	18	min.	dBu	Balanced, <1% THD, Load = 10 kΩ
Dynamic Range	103	typ.	dB	re: 0 dBFS, 20 kHz BW, A-weighted
Frequency Response	10 to 22k	typ.	Hz	+0, -3dB
THD+Noise	0.017	typ.	%	@ 1 kHz, 20 kHz BW, Output = -6 dBFS
Balanced Line-Level Input Specs				
Input Impedance	22.18 k	1%	Ω	Balanced 11.09 kΩ + 11.09 kΩ
Max. Input Level	23	min.	dBu	Balanced, <1% THD
Dynamic Range	102	typ.	dB	re: 0 dBFS, 20 kHz BW, A-weighted
CMRR	-56	typ.	dB	Rs = 150 Ω, 1 kHz
Frequency Response	10 to 22k	typ.	Hz	+0, -3dB
THD+Noise	0.004	typ.	%	@ 1 kHz, 20 kHz BW, Rs = 150 Ω, Output = -6 dBFS
Unbalanced Line-Level Input Specs				
Input Impedance, Mono	20 k	1%	Ω	(RAD2, RAD11 & RAD14)
Max. Input Level, Mono	6	min.	Vrms	<1% THD (RAD2, RAD11 & RAD14)
Input Impedance, Stereo	20 k	1%	Ω	(RAD6)
Max. Input Level, Stereo	3	min.	Vrms	<1% THD (RAD6)
Dynamic Range	96	typ.	dB	re: 0 dBFS, 20 kHz BW, A-weighted
Frequency Response	10 to 22k	typ.	Hz	+0, -3dB
THD+Noise	0.005	typ.	%	@ 1 kHz, 20 kHz BW, Rs = 150 Ω, Output = -6 dBFS
Unbalanced Line-Level Output Specs				
Output Impedance, Stereo	600	1%	Ω	(RAD6, RAD8, RAD11)
Max. Output Level, Stereo	3.3	min.	Vrms	<1% THD, Load = 10 kΩ (RAD6, RAD8, RAD11)
Dynamic Range	98	typ.	dB	Re: 0 dBFS, 20 kHz BW, A-weighted
Frequency Response	10 to 22k	typ.	Hz	+0, -3dB
THD+Noise	0.028	typ.	%	@ 1 kHz, 20 kHz BW, Output = -6 dBFS

RAD16 Features & Specifications

Note: the RAD16 is discontinued, and Mongoose is not compatible with the new RAD16z.

Parameter	Specification	Limit	Units	Conditions/Comments
Input Impedance	2.16 k	1%	Ω	Balanced 1.08 k + 1.08 k
Max. Input Level	-16	min.	dBu	Balanced, Gain = 26 dB, <1% THD
Equivalent Input Noise	-121	typ.	dBu	20 kHz BW, $R_s = 150 \Omega$, Gain = 26 dB
Dynamic Range	96	typ.	dB	re: 0 dBFS, 20 kHz BW, A-weighted, Gain = 26
CMRR	-62	typ.	dB	$R_s = 150 \Omega$, 1 kHz, Gain = 26 dB
Frequency Response	41 to 20k	typ.	Hz	+0, -3dB, At All Gain Settings
THD+Noise	0.008	typ.	%	@ 1 kHz, 20 kHz BW, $R_s = 150 \Omega$, Output = -6 dBFS, Gain = 26 dB
Gain Range	26 to 60	typ.	dB	In 1 dB Steps
Phantom Power	+24	4%	V	15 mA Max.
Impedance	1.21 k	1%	Ω	Each Leg
Balanced Line-Level Input Specs				
Input Impedance	22.60 k	1%	Ω	Balanced 11.3 k Ω + 11.3 k Ω
Max. Input Level	23	min.	dBu	Balanced, <1% THD
Dynamic Range	99	typ.	dB	re: 0 dBFS, 20 kHz BW, A-weighted
CMRR	-52	typ.	dB	$R_s = 150 \Omega$, 1 kHz
Frequency Response	22 to 22k	typ.	Hz	+0, -3 dB
THD+Noise	0.008	typ.	%	@ 1 kHz, 20 kHz BW, $R_s = 150 \Omega$, Output = -6 dBFS
Balanced Line-Level Output Specs (Active Balanced)				
Output Impedance	600	1%	Ω	Each Leg
Max. Output Level	18	min.	dBu	Balanced, <1% THD, Load = 10 k Ω
Dynamic Range	103	typ.	dB	20 kHz BW, A-weighted
Frequency Response	10 to 22k	typ.	Hz	+0, -3 dB
THD+Noise	0.07	typ.	%	@ 1 kHz, 20 kHz BW, Output = -6 dBFS
Unit: Conformity	CE, FCC, cULus			
Unit: Size	4.92" x 3.31" x 1.05"			(12.5 x 8.4 x 2.7 cm)
Weight	12 oz			(340 g)
Shipping Size	7.25" x 5.25" x 3.375"			(18.5 x 13.4 x 8.6 cm)
Shipping Weight	1 lb			(436 g)

RAD16 Dual Euroblock Mic or Line Input / Dual Euroblock Line Output (discontinued)

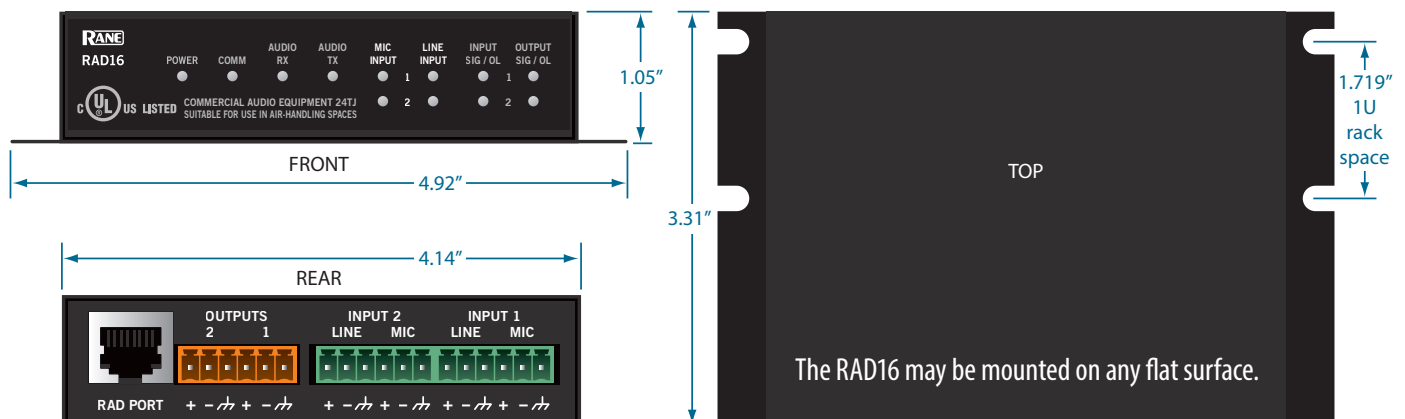

The RAD16 may be mounted on any flat surface.

RAD17 Microphone

This omnidirectional boundary layer microphone / PZM pressure zone electret microphone handles extreme temperatures and humidity for indoor or outdoor applications. It may be used for ambient noise sensing, surveillance, security, train stations, etc. Sold only in black, but the grill may be painted any color, and finished with any Decora® plate.



RAD17 Microphone Specifications

Parameter	Specification	Limit	Conditions/Comments
Built-in Microphone	Condenser / Electrostatic		Small capsule
...Capsule Sensitivity	6.3 mV/Pa (-44 dBu @ 1 Pa)	max	1 kHz, 1 Pa = 94 dB SPL
...Maximum Ambient SPL	114 dB SPL	max	120 dB SPL max at the microphone, Gain = 26 dB
...Gain Range	26 to 60 dB	typ	In 1 dB steps
...Frequency Response	100 Hz to 10 kHz	typ	±3 dB
Ambient Operating Temperature	-4 to +122 °F		-20 to +50 °C
Unit Size	4.1"H x 1.6"W x 0.9"D		10.4 x 4.0 x 2.3 cm (fits in 1-gang US electrical box)

RAD24 Amplifier

Note: the RAD24 is discontinued

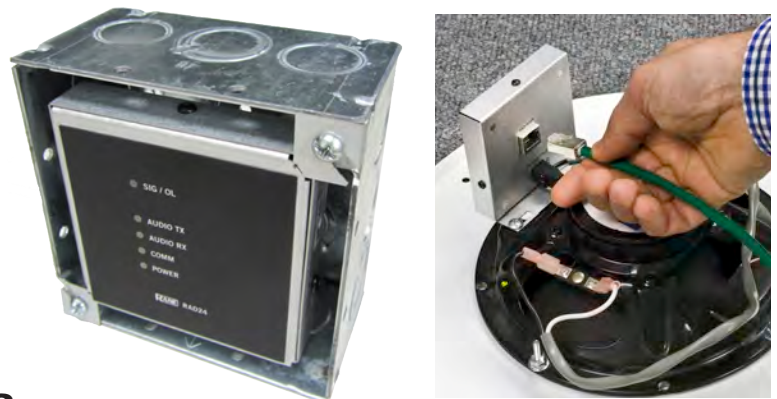

RAD24 Amplifier Specifications

Parameter	Specification	Limit	Conditions/Comments
Amplifier Output	1 Channel		Class D, full bridge, current limited
...Connector	Euroblock		2-pin, 5 mm pitch, black
...Maximum Output Power	1 W (0 dBW)	max	1 kHz, 0 dBFS, 8Ω, cable = 150 meters, THD < 1%
...Maximum Output Level	11.2 dBu / 2.83 Vrms		1 kHz, 0 dBFS, 8Ω, cable = 150 meters, THD < 1%
...Frequency Response	20 Hz - 20 kHz, +0 / -1 dB		0 dBFS, 8Ω
...THD+N	0.1%	max	1 kHz, 0 dBFS, 8Ω
...Dynamic Range	80 dB	typ	20 kHz BW, re: 11.2 dBu, 8Ω
...Power Taps	5 selections		1, 1/2, 1/4, 1/8, 1/16 W into 8Ω
Ambient Room Temperature	104 °F / 40 °C	max	Maximum external loading
Unit: Conformity	CE, FCC, cULus		
Unit: Size with mounting tabs	4.0"H x 4.0"W x 1.3"D		10.2 x 10.2 x 3.3 cm (fits in 4" US electrical box)
...Size without mounting tabs	3.1"H x 3.1"W x 1.3"D		7.9 x 7.9 x 3.3 cm (mount on loudspeaker or flat area)

All wallplate RADs are available in white, ivory or black



RAD1 Dual XLR Mic Inputs

RAD1W = white RAD1I = ivory RAD1B = black



RAD4 Dual XLR Line Outputs

RAD4W = white RAD4I = ivory RAD4B = black



**RAD2 XLR Mic Input /
Mini & RCA Mono'd Line Input**

RAD2W = white RAD2I = ivory RAD2B = black



RAD5 AES3 Input / AES3 Output

RAD5W = white RAD5I = ivory RAD5B = black



RAD3 Dual XLR Line Inputs

RAD3W = white RAD3I = ivory RAD3B = black



**RAD6 Mini & RCA Stereo Line Input /
Mini & RCA Stereo Line Output**

RAD6W = white RAD6I = ivory RAD6B = black

All wallplate RADs are available in white, ivory or black

RAD7 XLR Mic Input / XLR Line Input

RAD7W = white RAD7I = ivory RAD7B = black

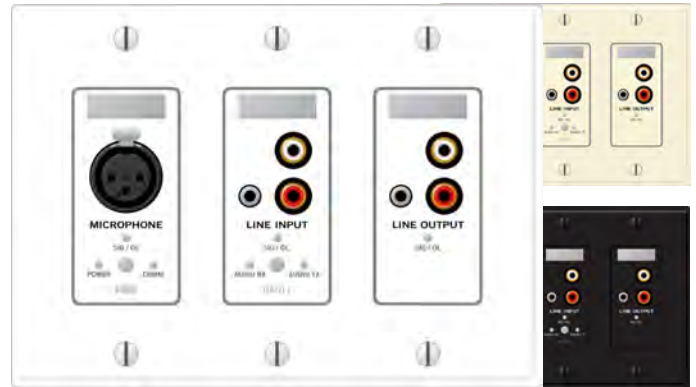
RAD11 XLR Mic Input / Mini & RCA Mono'd Line Input / Mini & RCA Stereo Line Output

RAD11W = white RAD11I = ivory RAD11B = black

RAD8 XLR Mic Input / Mini & RCA Stereo Line Output

RAD8W = white RAD8I = ivory RAD8B = black

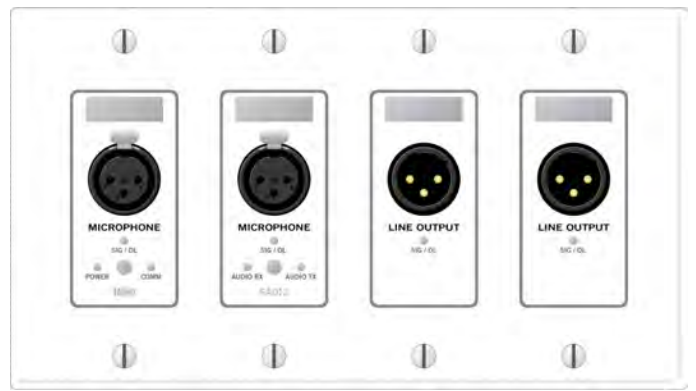
RAD12 Dual XLR Mic Inputs / Dual XLR Line Outputs

RAD12W = white RAD12I = ivory RAD12B = black

RAD9 XLR Mic Input / XLR Line Output

RAD9W = white RAD9I = ivory RAD9B = black

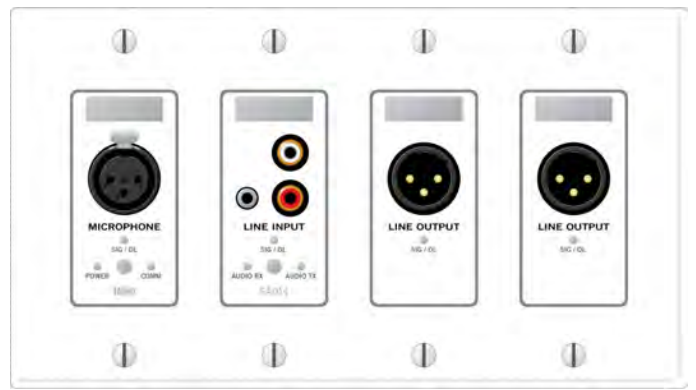
RAD14 XLR Mic Input / Mini & RCA Mono'd Line Input / Dual XLR Line Outputs

RAD14W = white RAD14I = ivory RAD14B = black

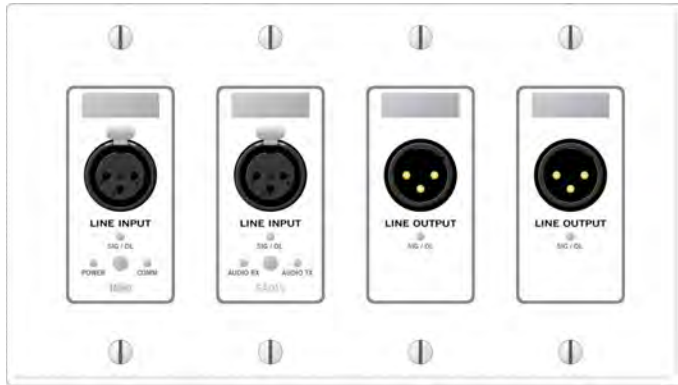

RAD15 Dual XLR Line Inputs / Dual XLR Line Outputs

RAD15W = white RAD15I = ivory RAD15B = black



RAD18 XLR Mic Input / 1/4 inch Balanced Line Input

RAD18W = white RAD18I = ivory RAD18B = black



RAD23 XLR Line Input / XLR Line Output

RAD23W = white RAD23I = ivory RAD23B = black



RADX RAD Port Extension

RADXW = white RADXI = ivory RADXB = black
Distinguish Ethernet RJ-45 from Audio RJ-45 jacks.



AM1 Automixer with 4 XLR Mic/Line Inputs, 2 Line Inputs, USB Audio I/O, XLR Mix Output, RCA Record Output, Headphone Amp, and RAD Port. See the AM1 Data Sheet for details



AM2 Automixer with 8 XLR Mic/Line Inputs, XLR Mix Output, and Cascadable RAD Port.

See the AM2 Data Sheet for details