

# SWITCHBLADE™

# MICRO

WIRELESS DMX  
WICICLE®  
ENABLED



Blizzard Lighting, LLC  
[www.blizzardlighting.com](http://www.blizzardlighting.com)  
Waukesha, WI USA  
Copyright (c) 2014

# TABLE OF CONTENTS

SwitchBlade™ Micro Moving Head Fixture	1
<b>1. Getting Started</b>	<b>3</b>
What's In The Box?	3
Getting It Out Of The Box	3
Powering Up!	3
Getting A Hold Of Us	3
Safety Instructions (Don't Stick Your Hand In The Toaster!)	4
<b>2. Meet The SwitchBlade™ Micro</b>	<b>5</b>
Main Features	5
Control	5
DMX Quick Reference	5
The SwitchBlade™ Micro Pin-up Picture	6
<b>3. Setup</b>	<b>7</b>
Fuse Replacement	7
Connecting A Bunch Of SwitchBlade™ Micro Fixtures	7
Data/DMX Cables	7
Cable Connectors	8
3-Pin??? 5-Pin??? Huh?	8
Take It To The Next Level: Setting up DMX Control	8
Fixture Linking (Master/Slave Mode)	9
Mounting/Rigging	9
Lighting Stand Mounting	9
<b>4. Operating Adjustments</b>	<b>10</b>
Navigating The Control Panel	10
Control Panel Menu Structure	11
DMX Mode	12
Set The DMX Starting Address	12
Select the DMX Channel Mode	12
Auto, Stand-Alone, & Built-in Program Modes	12
Auto Mode	12
Sound Active Mode	12
Manual Adjustments	12
Reverse Pan	12
Reverse Tilt	12
Reverse (Flip) the Menu Display	12
Restore Default Settings	13
Pan/Tilt Motor Reset	13
DMX Channel Values In-Depth	13
Troubleshooting	13
<b>5. Appendix</b>	<b>15</b>
A Quick DMX Lesson	15
Keeping Your SwitchBlade™ Micro As Good As New	16
Returns (Gasp!)	16
Shipping Issues	16
Tech Specs	17
Luminous Intensity	18
Dimensional Drawings	18

# 1. GETTING STARTED

## What's In The Box?

- 1 x SwitchBlade™ Micro Moving Head Fixture
- 1 x Mounting Bracket
- An Ever-So-Handy Power Cord
- This Lovely User Manual

## Getting It Out Of The Box

Congratulations! You have just purchased one totally tiny, totally cool quad-color mini moving head fixture that is sure to make a giant impression anywhere it goes! So now that you're the proud owner of a SwitchBlade™ Micro (or hopefully, MICROS!), you should carefully unpack the box and check the contents to ensure that all parts are present and in good condition. If anything looks as if it has been damaged in transit, notify the shipper immediately and keep the packing material for inspection. Again, please save the carton and all packing materials. If a fixture must be returned to the factory, it is important that the fixture be returned in the original factory box and packing.

## Powering Up!

All fixtures must be powered directly off a switched circuit and **cannot be run off a rheostat (variable resistor) or dimmer circuit, even if the rheostat or dimmer channel is used solely for a 0% to 100% switch.**

*AC Voltage Switch* - Not all fixtures have a voltage select switch, so please verify that the fixture you receive is suitable for your local power supply. See the label on the fixture or refer to the fixture's specifications chart for more information. A fixture's listed current rating is its average current draw under normal conditions. Check the fixture or device carefully to make sure that if a voltage selection switch exists that it is set to the correct line voltage you will use.

**Warning! Verify that the voltage select switch on your unit matches the line voltage applied. Damage to your fixture may result if the line voltage applied does not match the voltage indicated on the voltage selector switch. All fixtures must be connected to circuits with a suitable Ground (Earthing).**

## Getting A Hold Of Us

**If something is wrong, just give us a call or send an email. We'll be happy to help, honest.**

Blizzard Lighting  
N16 W23390 Stoneridge Dr. Ste E  
Waukesha, WI 53118 USA  
www.blizzardlighting.com  
414-395-8365  
Email: support@blizzardlighting.com

**Disclaimer:** The information and specifications contained in this document are subject to change without notice. Blizzard Lighting™ assumes no responsibility or liability for any errors or omissions that may appear in this user manual. Blizzard Lighting™ reserves the right to update the existing document or to create a new document to correct any errors or omissions at any time. You can download the latest version of this document from [www.blizzardlighting.com](http://www.blizzardlighting.com).

Author:	Date:	Last Edited:	Date:
J. Thomas	5/30/2014	J. Thomas	5/30/2014

# SAFETY INSTRUCTIONS



Please read these instructions carefully. They include important information about the installation, usage and maintenance of this product.

- Please keep this User Guide for future use. If you sell the unit to someone else, be sure that they also receive this User Guide.
- ALWAYS make sure that you are connecting to the proper voltage, and that the line voltage you are connecting to is not higher than that stated on the decal or rear panel of the fixture.
- This product is intended for indoor use only.
- To prevent risk of fire or shock, do not expose fixture to rain or moisture.
- Make sure there are no flammable materials close to the unit while operating.
- The unit must be installed in a location with adequate ventilation, at least 20in (50cm) from adjacent surfaces. Be sure that no ventilation slots are blocked.
- ALWAYS disconnect from the power source before servicing or replacing fuse and be sure to replace with same fuse size and type.
- ALWAYS secure fixture using a safety chain. NEVER carry the fixture by its cord. Use its carrying handles.
- DO NOT operate at ambient temperatures higher than 104°F (40°C).
- In the event of a serious operating problem, stop using the unit immediately. NEVER try to repair the unit by yourself. Repairs carried out by unskilled people can lead to damage or malfunction. Please contact the nearest authorized technical assistance center. Always use the same type spare parts.
- NEVER connect the device to a dimmer pack.
- Make sure the power cord is never crimped or damaged.
- Never disconnect the power cord by pulling or tugging on the cord.
- Avoid direct eye exposure to the light source while it is on.

**Caution!** There are no user serviceable parts inside the unit. Do not open the housing or attempt any repairs yourself. In the unlikely event your unit may require service, please contact Blizzard Lighting at [support@blizzardlighting.com](mailto:support@blizzardlighting.com).

## 2. MEET THE SWITCHBLADE™ MICRO

### MAIN FEATURES:

- Mini moving head fitted with 1x CREE® 15w R/G/B/W 4-in-1 LED
- Blazing fast 540° pan and 270° tilt
- User selectable 11 or 13 DMX channels
- Full RGBW color in standalone & DMX mode
- Sharp 8 degree beam angle
- Outstanding quad beam effects
- Built-in sound active programs
- Built-in automated programs via master/slave
- Built-in sound activated programs via master/slave
- 3-pin male input and 3-pin female output
- wiCICLE® Enabled functionality allows plug-and-play operation with our wiCICLE® Brand Wireless DMX system

### CONTROL:

- USITT DMX-512 (11/13 Channels)
- 3-pin Input/Output
- 4-button menu with LED display

### DMX Quick Reference (11/13-Channel Modes)

Channel	11-Channel Mode	13-Channel Mode
1	Pan (0-540°)	Pan (0-540°)
2	Tilt (0-270°)	Tilt (0-270°)
3	Fine Pan (fast <--> slow)	Fine Pan (fast <--> slow)
4	Fine Tilt (fast <--> slow)	Fine Tilt (fast <--> slow)
5	Pan/Tilt Speed (slow <--> fast)	Pan/Tilt Speed (slow <--> fast)
6	Dimmer (0% <--> 100%)	Dimmer (0% <--> 100%)
7	Strobe (slow <--> fast)	Strobe (slow <--> fast)
8	Red Intensity (0% <--> 100%)	Red Intensity (0% <--> 100%)
9	Green Intensity (0% <--> 100%)	Green Intensity (0% <--> 100%)
10	Blue Intensity (0% <--> 100%)	Blue Intensity (0% <--> 100%)
11	White Intensity (0% <--> 100%)	White Intensity (0% <--> 100%)
12	---	Built-in Programs, Sound Active
13	---	Motor Reset (150-200)

**Figure 1: The SwitchBlade™ Micro Pin-Up Picture**



**Figure 2: The Rear Connections**



### 3. SETUP



Before replacing a fuse, disconnect power cord. ALWAYS replace with the same type and rating of fuse.

#### Fuse Replacement

With a flat head screwdriver, wedge the fuse holder out of its housing. Remove the damaged fuse from its holder and replace with exact same type fuse. Insert the fuse holder back in its place and reconnect power.

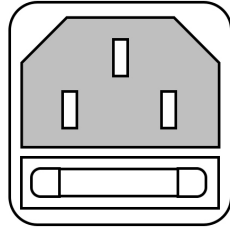

#### Connecting A Bunch of SwitchBlade™ Micro Fixtures

You will need a serial data link to run light shows using a DMX-512 controller or to run shows on two or more fixtures set to sync in master/slave operating mode. The combined number of channels required by all the fixtures on a serial data link determines the number of fixtures the data link can support.

Fixtures on a serial data link must be daisy chained in one single line. Also, connecting more than 32 fixtures on one serial data link without the use of a DMX optically-isolated splitter may result in deterioration of the digital DMX signal.

The maximum recommended cable-run distance is 500 meters (1640 ft). The maximum recommended number of fixtures on a serial data link is 32 fixtures.

#### Data/DMX Cabling

To link fixtures together you'll need data cables. You should use data-grade cables that can carry a high quality signal and are less prone to electromagnetic interference.

For instance, Belden© 9841 meets the specifications for EIA RS-485 applications. Standard microphone cables will "probably" be OK, but note that they cannot transmit DMX data as reliably over long distances. In any event, the cable should have the following characteristics:

*2-conductor twisted pair plus a shield*  
*Maximum capacitance between conductors – 30 pF/ft.*  
*Maximum capacitance between conductor & shield – 55 pF/ft.*  
*Maximum resistance of 20 ohms / 1000 ft.*  
*Nominal impedance 100 – 140 ohms*

## Cable Connectors

Cables must have a male XLR connector on one end and a female XLR connector on the other end. (Duh!)

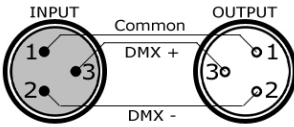

**A Word on Termination:** DMX is a resilient communication protocol, however errors still occasionally occur. Termination reduces signal errors, and therefore best practices include use of a terminator in all circumstances. If you are experiencing problems with erratic fixture behavior, especially over long signal cable runs, a terminator may help improve performance.

**To build your own DMX Terminator:**  
Obtain a 120-ohm, 1/4-watt resistor, and wire it between pins 2 & 3 of the last fixture. They are also readily available from specialty retailers.

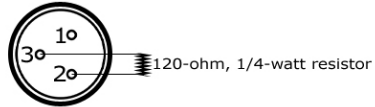

**CAUTION:** Do not allow contact between the common and the fixture’s chassis ground. Grounding the common can cause a ground loop, and your fixture may perform erratically. Test cables with an ohm meter to verify correct polarity and to make sure the pins are not grounded or shorted to the shield or each other.

## 3-Pin??? 5-Pin??? Huh?!?

If you use a controller with a 5 pin DMX output connector, you will need to use a 5 pin to 3 pin adapter. They are widely available over the internet and from specialty retailers. If you’d like to build your own, the chart below details a proper cable conversion:

Conductor	3-Pin Female (Output)	5-Pin Male (Input)
Ground/Shield	Pin 1	Pin 1
DMX Data (-)	Pin 2	Pin 2
DMX Data (+)	Pin 3	Pin 3
Not Used.	No Connection.	No Connection.
Not Used.	No Connection.	No Connection.

## Take It To The Next Level: Setting Up DMX Control

**Step 1:** Connect the male connector of the DMX cable to the female connector (output) on the controller.



**Step 2:** Connect the female connector of the DMX cable to the first fixture’s male connector (input). *Note:* It doesn’t matter which fixture address is the first one connected. We recommend connecting the fixtures in terms of their proximity to the controller, rather than connecting the lowest fixture number first, and so on.

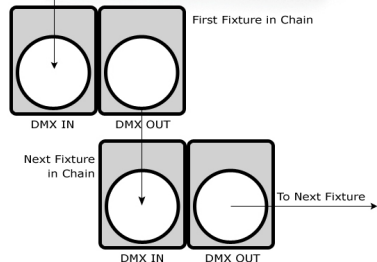

**Step 3:** Connect other fixtures in the chain from output to input as above. Place a DMX terminator on the output of the final fixture to ensure best communication.

## Fixture Linking (Master/Slave Mode)

1. Connect the (male) 3 pin connector side of the DMX cable to the output (female) 3 pin connector of the first fixture.
2. Connect the end of the cable coming from the first fixture which will have a (female) 3 pin connector to the input connector of the next fixture consisting of a (male) 3 pin connector. Then, proceed to connect from the output as stated above to the input of the following fixture and so on.

**A quick note:** Often, the setup for Master-Slave and Standalone operation requires that the first fixture in the chain be initialized for this purpose via either settings in the control panel or DIP-switches. Secondly, the fixtures that follow may also require a slave setting.

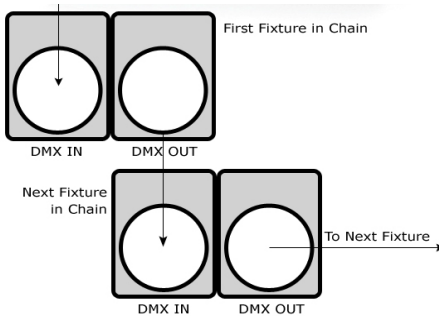

Check the **“Operating Adjustments”** section in this manual for complete instructions for this type of setup and configuration.

## Mounting & Rigging

This fixture may be mounted in any SAFE position provided there is enough room for ventilation.

It is important never to obstruct the fan or vents pathway. Mount the fixture using a suitable “C” or “O” type clamp. The clamp should be rated to hold at least 10x the fixture’s weight to ensure structural stability. Do not mount to surfaces with unknown strength, and ensure properly “rated” rigging is used when mounting fixtures overhead.

Adjust the angle of the fixture by loosening both knobs and tilting the fixture. After finding the desired position, retighten both knobs.

- When selecting installation location, take into consideration lamp replacement access (if applicable) and routine maintenance.
- Safety cables **MUST ALWAYS** be used.
- Never mount in places where the fixture will be exposed to rain, high humidity, extreme temperature changes or restricted ventilation.

## Lighting Stand Mounting

This fixture comes with an easy to use stand mounting bracket. Please make sure the lighting stand you use is rated to safely hold the weight of this unit and do not over-extend the lighting stand. For the safety of yourself, your audience, and the fixture... always take advantage of the use of the stand’s safety pins!

# USING THIS FIXTURE WITH THE wiCICLE® WIRELESS DMX SYSTEM

In addition to the unbridled thrill you already received the first time you plugged in your fixture, you'll be delighted to know that This fixture also works seamlessly with our wiCICLE® Wireless DMX system, **without additional power.**



- ONLY fixtures bearing this logo are certified for use with the wiCICLE® without external power.

- **Unauthorized modification and/or using the wiCICLE® with unapproved fixtures may cause damage to the wiCICLE® or fixture. UNDER NO CIRCUMSTANCES IS BLIZZARD LIGHTING RESPONSIBLE FOR ANY DAMAGE FROM SUCH OPERATION.**

- Fixtures bearing the above logo **MUST** only use cable and connectors which separate chassis/case ground from cable shielding. Cabling with the shield connected to the connector's case/chassis may cause malfunction and damage to the wiCICLE® or fixture.

- wiCICLE® transmitters have additional power requirements and therefore cannot be powered directly from the fixture. You will need to utilize the supplied AC/DC adaptor to drive wiCICLE® transmitters in your system.

## WE HAD THIS SPACE, SO WE FIGURED WE'D DRAW YOU A PICTURE:

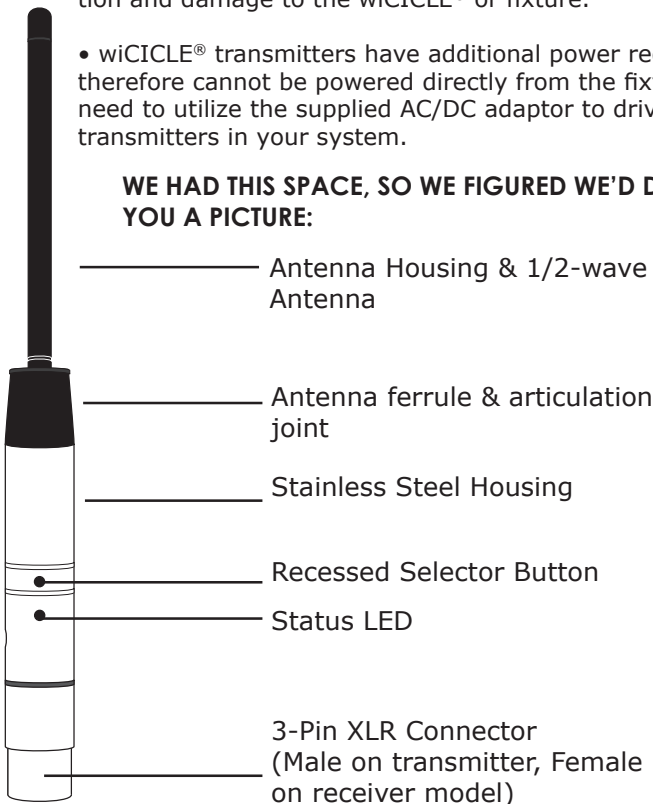

Each wiCICLE® acts as both a transmitter and a receiver, depending on whether a DMX source is applied to the integral XLR connector. This is an extremely powerful feature of the system, however, it also requires 1 piece of due diligence, and that is the removal of extraneous DMX signals from your lighting rig BEFORE proceeding.

**SO: BEFORE DOING ANYTHING ELSE, YOU SHOULD DISABLE ANY BUILT-IN PROGRAMS IN THE FIXTURES YOU WISH TO CONNECT AND/OR SET THEM AS SLAVES PRIOR TO RETURNING THEM TO DMX MODE (IF APPLICABLE). Most fixtures contain a built-in automatic, sound active or custom program which is designed to operate with the fixture NOT connected to a DMX chain.**

Some of these programs will automatically run unless the fixture is set to slave mode. These fixtures typically sense DMX automatically and switch to DMX mode upon receiving DMX signal (our Pucks do that!)

If you plug a wiCICLE® “receiver” into an autosensing fixture set as a “master,” chances are good that the wiCICLE® “receiver” will begin transmitting the master program. Most times, this is undesirable, and taking the two seconds to switch these programs off will solve a lot of ails.

Got that done? Good! Then let’s proceed!

1. Plug the wiCICLE® Receiver into the “DMX IN” connector of the fixture and verify it is receiving power (the **STATUS LED** should illuminate.)
2. Connect the AC/DC adaptor to the wiCICLE® Transmitter and verify it is receiving power (the **STATUS LED** should illuminate.)
3. Press the **RECESSED SELECTOR BUTTON** on the Transmitter to select the operating channel group. (The system will store this setting for future use)

The 7-Color Status LED will change color to indicate the current channel group:

- GROUP 1: **RED**
- GROUP 2: **GREEN**
- GROUP 3: **YELLOW**
- GROUP 4: **BLUE**
- GROUP 5: **VIOLET**
- GROUP 6: **CYAN**
- GROUP 7: **WHITE**

**NOTE: “GROUP” number also corresponds to the “GROUP” setting on our LightCaster™ wireless DMX Transceiver.**

4. Follow the same procedure on the Receiver to select the channel group.
5. Once both the transmitter and receiver(s) are both set to the same channel group, connect the transmitter to the DMX controller or the DMX out of a fixture on your DMX chain.
6. Once a DMX signal is provided to the transmitter, the status LED will blink **RED** slowly until communication is established with the receiver. The status LED on the receiver(s) will flash **GREEN** slowly until communication is established.
7. Once the clearest channel is auto-selected, the status LEDs will blink quickly on both the transmitter and receiver. NOTE: The color of the LED DURING operation does not indicate channel group, instead it indicates whether the unit is transmitting or receiving. **That’s It!**

## 4. OPERATING ADJUSTMENTS

### The Control Panel

All the goodies and different modes possible with the SwitchBlade™ Micro are accessed by using the control panel on the rear of the fixture. There are 4 control buttons below the LED display which allow you to navigate through the various control panel menus.

#### <MENU>

Is used to navigate to the previous higher-level menu item.

#### <UP>

Scrolls through menu items and numbers in ascending order.

#### <DOWN>

Scrolls through menu items and numbers in descending order.

#### <ENTER>

Is used to select and confirm/store the current selection.

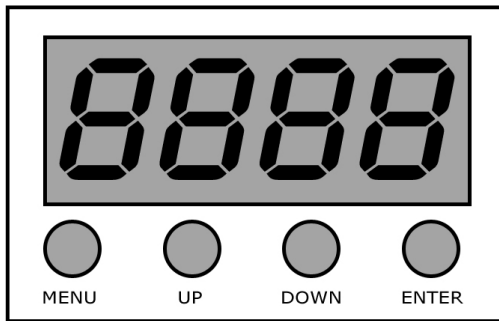

The Control Panel LED Display shows the menu items you select from the menu map on page #11. When a menu function is selected, the display will show immediately the first available option for the selected menu function. To select a menu item, press **<ENTER>**.

Use the **<MENU>** button to navigate the main menu options. Press the **<ENTER>** button to select the menu function currently displayed. Then use the **<UP/DOWN>** buttons to scroll through any submenu options, and press **<ENTER>** to save. To return to the previous option or menu, press the **<MENU>** button.

## Control Panel Menu Structure

<i>ADD 1</i>	<i>ADD 1 - AS 12</i>	To choose the DMX address
<i>CH ---</i>	<i>CH 13</i>	13-channel DMX mode
	<i>CH 11</i>	11-channel DMX mode
<i>RU ---</i>	<i>RU01 - RU02</i>	Auto mode (1=fast, 2=slow)
<i>Sound</i>	<i>SO.ON</i>	Sound Active = On
	<i>SO.OF</i>	Sound Active = Off
<i>rRnu</i>	<i>H000 - H255</i>	Pan (0° <--> 540°)
	<i>T000 - T255</i>	Tilt (0° <--> 270°)
	<i>rR00 - rR255</i>	Red dimmer (0% <--> 100%)
	<i>G000 - G255</i>	Green dimmer (0% <--> 100%)
	<i>B000 - B255</i>	Blue dimmer (0% <--> 100%)
	<i>W000 - W255</i>	White dimmer (0% <--> 100%)
<i>rP ---</i>	<i>rP.oF</i>	Reverse Pan = Off
	<i>rP.oN</i>	Reverse Pan = On
<i>rT ---</i>	<i>rT.oF</i>	Reverse Tilt = Off
	<i>rT.oN</i>	Reverse Tilt = On
<i>rd ---</i>	<i>rd.oF</i>	Reverse Display = Off
	<i>rd.oN</i>	Reverse Display = On
<i>dF ---</i>	<i>dF.oF</i>	Restore default settings = No
	<i>dF.oN</i>	Restore default settings = Yes
<i>rSt</i>	<b>&lt;ENTER&gt;</b>	Motor Reset

## DMX Mode

*Allows the unit to be controlled by any universal DMX controller.*

### Set the Starting DMX Address:

The default mode for the fixture is DMX, so the first menu item that you can edit is the starting DMX address.

- 1.) Navigate the menu using the **<MENU>** button until you reach **A001**.
- 2.) Push the **<ENTER>** button.
- 3.) Use the **<UP/DOWN>** buttons to select a DMX channel from **001-512**.
- 4.) Press the **<ENTER>** button to confirm.

### Select the DMX Channel Mode:

- 1.) Navigate the menu using the **<MENU>** button until you reach **CH--**.
- 2.) Push the **<ENTER>** button.
- 3.) Use the **<UP/DOWN>** buttons to select either **CH11** or **13CH** mode.
- 4.) Press the **<ENTER>** button to confirm.

## Auto, Stand-Alone, & Built-in Program Modes:

*Allows a single or Master/Slaved units to run factory installed programs at user selectable speeds.*

### Auto Mode:

- 1.) Navigate the menu using the **<MENU>** button until you reach **Au--**.
- 2.) Push the **<ENTER>** button.
- 3.) Use the **<UP/DOWN>** buttons to select either **Au01** (fast) or **Au02** (slow).
- 4.) Press the **<ENTER>** button to confirm.

### Sound Active Mode:

- 1.) Navigate the menu using the **<MENU>** button until you reach **Sound**.
- 2.) Push the **<ENTER>** button.
- 3.) Use the **<UP/DOWN>** buttons to select either **So.on** (On) or **So.of** (Off).
- 4.) Press the **<ENTER>** button to confirm.

### Manual Adjustments:

- 1.) Navigate the menu using the **<MENU>** button until you reach **nAnu**.
- 2.) Navigate the submenu using the **<UP/DOWN>** buttons until you reach **H---** (Pan), **Y---** (Tilt), **r---** (Red), **g---** (Green), **b---** (Blue), or **u---** (White) then hit **<ENTER>**.
- 3.) Using the **<UP/DOWN>** buttons, select your desired value for each between **x000-x255**, then hit **<ENTER>** to confirm.

### Reverse Pan

- 1.) Navigate the menu using the **<MENU>** button until you reach **rPoF**.
- 2.) Push the **<ENTER>** button.
- 3.) Use the **<UP/DOWN>** buttons to select either **rPoF** (Off) or **rPon** (On).
- 4.) Press the **<ENTER>** button to confirm.

### Reverse Tilt

- 1.) Navigate the menu using the **<MENU>** button until you reach **rtoF**.
- 2.) Push the **<ENTER>** button.
- 3.) Use the **<UP/DOWN>** buttons to select either **rtoF** (Off) or **rton** (On).
- 4.) Press the **<ENTER>** button to confirm.

### Reverse (Flip) the Menu Display

- 1.) Navigate the menu using the **<MENU>** button until you reach **rdoF**.
- 2.) Push the **<ENTER>** button.
- 3.) Use the **<UP/DOWN>** buttons to select either **rdoF** (No) or **rdon** (Yes).
- 4.) Press the **<ENTER>** button to confirm.

### Restore Default Settings

This will restore all of the default settings including pan/tilt reversal and the starting DMX address.

- 1.) Navigate the menu using the **<MENU>** button until you reach **dFOF**.
- 2.) Push the **<ENTER>** button.
- 3.) Use the **<UP/DOWN>** buttons to select either **dFOF** (No) or **dFOn** (Yes).
- 4.) Press the **<ENTER>** button to confirm.

### Pan/Tilt Motor Reset

- 1.) Navigate the menu using the **<MENU>** button until you reach **rSt**.
- 2.) Press the **<ENTER>** button to confirm.

## DMX Values In-Depth (13-Channel Mode)

Channel	Value	What It Does
1	000 <--> 255	Pan (0-540°)
2	000 <--> 255	Tilt (0-270°)
3	000 <--> 255	Fine Pan (fast <--> slow)
4	000 <--> 255	Fine Tilt (fast <--> slow)
5	000 <--> 255	Pan/Tilt Speed (slow <--> fast)
6	000 <--> 255	Dimmer (0% <--> 100%)
7	000 <--> 255	Strobe (slow <--> fast)
8	000 <--> 255	Red Intensity (0% <--> 100%)
9	000 <--> 255	Green Intensity (0% <--> 100%)
10	000 <--> 255	Blue Intensity (0% <--> 100%)
11	000 <--> 255	White Intensity (0% <--> 100%)
12	000 <--> 010	<b>Built-in Programs, Sound Active</b> No Function
	011 <--> 020	Red
	021 <--> 030	Green
	031 <--> 040	Blue
	041 <--> 050	White
	051 <--> 060	Red+Green
	061 <--> 070	Green+Blue
	071 <--> 080	Blue+White
	081 <--> 090	Red+White
	091 <--> 100	Red+Blue
	101 <--> 110	Green+White
	111 <--> 120	Red+Green+Blue
	121 <--> 130	Green+Blue+White
	131 <--> 140	Red+Blue+White
	141 <--> 150	Red+Green+White
151 <--> 160	Red+Green+Blue+White	
161 <--> 200	Color Snap (Slow <--> Fast)	
201 <--> 240	Color Fade (Slow <--> Fast)	
241 <--> 255	Sound Active Mode	
13	000 <--> 149	No Function
	150 <--> 200	Motor Reset
	201 <--> 255	No Function

## DMX Values In-Depth (11-Channel Mode)

Channel	Value	What It Does
1	000 <--> 255	Pan (0-540°)
2	000 <--> 255	Tilt (0-270°)
3	000 <--> 255	Fine Pan (fast <--> slow)
4	000 <--> 255	Fine Tilt (fast <--> slow)
5	000 <--> 255	Pan/Tilt Speed (slow <--> fast)
6	000 <--> 255	Dimmer (0% <--> 100%)
7	000 <--> 255	Strobe (slow <--> fast)
8	000 <--> 255	Red Intensity (0% <--> 100%)
9	000 <--> 255	Green Intensity (0% <--> 100%)
10	000 <--> 255	Blue Intensity (0% <--> 100%)
11	000 <--> 255	White Intensity (0% <--> 100%)

## Troubleshooting

Symptom	Solution
Fixture Auto-Shut Off	Check the fan in the fixture. If it is stopped or moving slower than normal, the unit may have shut itself off due to high heat. This is to protect the fixture from overheating. Clear the fan of obstructions, or return the unit for service.
Beam is Dim	Check optical system and clean excess dust/grime. Also ensure that the 220V/110V switch is in the correct position, if applicable.
No Light Output	Check to ensure fixture is operating under correct mode, IE sound active/auto/DMX/Etc., if applicable. Contact service for more information.
Chase Speed Too Fast/Slow	Check to ensure proper setup of speed adjustment.
No Power	Check fuse, AC cord and circuit for malfunction.
No Response to Audio	Verify that the fixture is in "Sound Active" mode. Adjust Audio Sensitivity, If Applicable.
Fixture Not Responding / Responding Erratically	Make sure all connectors are seated properly and securely. Use Only DMX Cables. Install a Terminator. Check all cables for defects. Reset fixture(s).

**If your problem isn't listed, or if problems persist, please contact support: [support@blizzardlighting.com](mailto:support@blizzardlighting.com).**

# 5. APPENDIX

## A Quick Lesson On DMX

DMX covers (and is an abbreviation for) Digital MultipleXed signals. It is the most common communications standard used by lighting and related stage equipment.

DMX provides up to 512 control “channels” per data link. Each of these channels was originally intended to control lamp dimmer levels. You can think of it as 512 faders on a lighting console, connected to 512 light bulbs. Each slider’s position is sent over the data link as an 8-bit number having a value between 0 and 255. The value 0 corresponds to the light bulb being completely off while 255 corresponds to the light bulb being fully on.

DMX data is transmitted at 250,000 bits per second using the RS-485 transmission standard over two wires. As with microphone cables, a grounded cable shield is used to prevent interference with other signals.

There are five pins on a DMX connector: a wire for ground (cable shield), two wires for “Primary” communication which goes from a DMX source to a DMX receiver, and two wires for a “Secondary” communication which goes from a DMX receiver back to a DMX source. Generally, the “Secondary” channel is not used so data flows only from sources to receivers. Hence, most of us are most familiar with DMX-512 as being employer over typical 3-pin “mic cables,” although this does not conform to the defined standard.

DMX is connected using a daisy-chain configuration where the source connects to the input of the first device, the output of the first device connects to the input of the next device, and so on. The standard allows for up to 32 devices on a single DMX link.

Each receiving device typically has a means for setting the “starting channel number” that it will respond to. For example, if two 6-channel fixtures are used, the first fixture might be set to start at channel 1 so it would respond to DMX channels 1 through 6, and the next fixture would be set to start at channel 7 so it would respond to channels 7 through 12.

### Dimensional Drawings

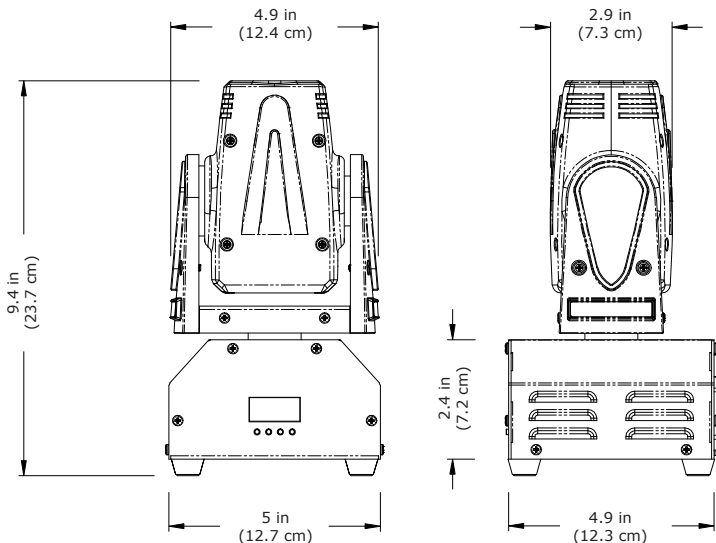

## Keeping Your SwitchBlade™ Micro As Good As New

The fixture you've received is a rugged, tough piece of pro lighting equipment, and as long as you take care of it, it will take care of you. That said, like anything, you'll need to take care of it if you want it to operate as designed. You should absolutely keep the fixture clean, especially if you are using it in an environment with a lot of dust, fog, haze, wild animals, wild teenagers or spilled drinks.

Cleaning the optics routinely with a suitable glass cleaner will greatly improve the quality of light output. Keeping the fans free of dust and debris will keep the fixture running cool and prevent damage from overheating.

In transit, keep the fixtures in cases. You wouldn't throw a prized guitar, drumset, or other piece of expensive gear into a gear trailer without a case, and similarly, you shouldn't even think about doing it with your shiny new light fixtures.

Common sense and taking care of your fixtures will be the single biggest thing you can do to keep them running at peak performance and let you worry about designing a great light show, putting on a great concert, or maximizing your client's satisfaction and "wow factor." That's what it's all about, after all!

## Returns (Gasp!)

We've taken a lot of precautions to make sure you never even have to worry about sending a defective unit back, or sending a unit in for service. But, like any complex piece of equipment designed and built by humans, once in a while, something doesn't go as planned. If you find yourself with a fixture that isn't behaving like a good little fixture should, you'll need to obtain a Return Authorization (RA).

Don't worry, this is easy. Just send an email to [support@blizzardlighting.com](mailto:support@blizzardlighting.com), and we'll issue you an RA. Then, you'll need to send the unit to us using a trackable, pre-paid freight method. We suggest using USPS Priority or UPS. Make sure you carefully pack the fixture for transit, and whenever possible, use the original box & packing for shipping.

When returning your fixture for service, be sure to include the following:

- 1.) Your contact information (Name, Address, Phone Number, Email address).
- 2.) The RA# issued to you
- 3.) A brief description of the problem/symptoms.

We will, at our discretion, repair or replace the fixture. Please remember that any shipping damage which occurs in transit to us is the customer's responsibility, so pack it well!

## Shipping Issues

**Damage incurred in shipping is the responsibility of the shipper, and must be reported to the carrier immediately upon receipt of the items. Claims must be made within seven (7) days of receipt.**

## Tech Specs!

<b>Weight &amp; Dimensions</b>						
Length	4.9 inches (12.3 cm)					
Width	5 inches (12.4 mm)					
Height	9.4 inches (23.7 mm)					
Weight	4.41 lbs (2 kg)					
<b>Power</b>						
Operating Voltage	AC 100-240VAC, 47-63 Hertz					
Power Consumption	35w					
<b>Light Source</b>						
LED	1* 15-watt R/G/B/W CREE® LED					
<b>Optical</b>						
Beam Angle	8 degree					
Luminous Intensity	Lux/m	Red	Green	Blue	White	All
	1m	3,760	3,397	5,690	6,780	16,890
	2m	985	961	1,457	1,872	6,710
<b>Thermal</b>						
Max. Operating Temp.	104 degrees F (40 degrees C) ambient					
<b>Control</b>						
Protocol	USITT DMX-512					
DMX Channels	11 or 13 Channels					
Input	3-pin XLR Male					
Output	3-pin XLR Female					
Other Operating Modes	Standalone, Master/Slave, Auto, Sound Active					
<b>Other Information</b>						
I just wanted to waste a little more time. Okay, that should do it.						
<b>Warranty</b>	2-year limited warranty, does not cover malfunction caused by damage to LED's.					



**Enjoy your product!  
Our sincerest thanks for your purchase!  
--The team @ Blizzard Lighting**