

FreeSpace® ZA 2120-HZ Zone Amplifier

BOSE

TECHNICAL DATA SHEET

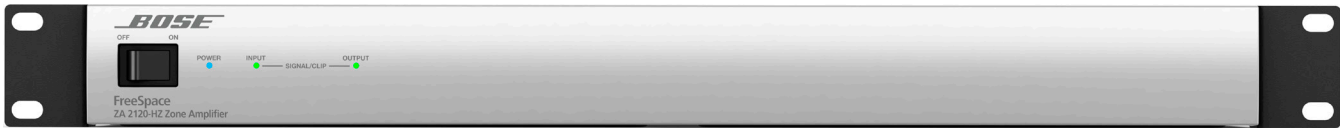

Product Description

The Bose® FreeSpace® ZA 2120-HZ zone amplifier is designed to provide basic amplification and sound system expansion when using front-end Bose products such as FreeSpace® integrated zone amplifiers and ControlSpace® engineered sound processors.

Key Features

- **Reliable 2 x 120 W Class-D amplification** optimized for 70/100V high-impedance applications.
- **Dual remotes** support optional volume adjustment for independent, or combined, zone control which eliminates the need for bulky, inefficient, and sound-altering 70/100V in-line volume controls.
- **Expansion-ready connectivity** with FreeSpace® IZA amplifiers when additional sources and loudspeaker processing is required.
- **Intuitive feature setup** enables the amplifier to be configured without a PC for remote, input, output and automatic standby options.
- **Auto-Standby feature** allows the amplifier to consume less power when not in use.
- **Remote muting** allows the amplifier to be muted via a centralized control system.

Applications

- Designed for a wide range of applications, including:
- Retail stores
- Restaurants and bars
- Hospitality venues
- Conference centers
- Schools
- Auxiliary zones

FreeSpace® ZA 2120-HZ Zone Amplifier



Technical Specifications

Power Rating	
Amplifier Power	2 x 120 W @ 70/100V
Audio Performance	
Frequency Response	55 Hz - 20 kHz (+0/-3 dB, @ 1 W reference 1 kHz)
THD+N	≤ 0.3 % (at rated power)
Channel Separation (Crosstalk)	≤ -58 dBu (below rated power, 1 kHz)
Dynamic Range	88 dB
Audio Inputs	
Input Channels	1 unbalanced, 1 balanced
Connectors	Stereo RCA, 5-pin Euroblock
Input Range	-8 dBu to 22 dBu
Input Impedance	20 kΩ
Maximum Input Level	22 dBu
Nominal Input Level	4 dBu
Audio Outputs	
Outputs	2
Connectors	2-pin inverted Euroblock
Nominal Output Level	2 x 120 W @ 70/100V
Indicators and Controls	
Power LED	Solid blue indicates power is on, blinking blue indicates standby mode
Input Signal Clip LED	Green indicates input signal is within -37 dBu to 11 dBu, red indicates signal is over 11 dBu
Output Signal Clip LED	Green indicates output signal is within -46 dBFS to -2 dBFS, red indicates signal is over -2 dBFS, approximately 80 W/channel, for each output 120 watts is 0 dBFS
Controls, Front Panel	Power On/Off
Controls, Rear Panel	Auto Standby: On/Off switch, Input: Dual/Summed switch, Remote 1 Control: Zone 1/Zone 1+2 switch, Output Voltage: 70/100V switch, Mute, Output trims, Remote (x2)
Electrical	
Mains Voltage	100 VAC - 240 VAC (±10%, 50/60 Hz)
AC Power Consumption	23 W (Standby), 300 W (Max)
Mains Connector	Standard IEC (C14)
Maximum Inrush Current	12.6 Amps (230 VAC / 50 Hz), 7.8 Amps (120 VAC / 60 Hz)
Overload Protection	High temperature, output short, excessively low or high AC line voltage
Physical	
Dimensions	1.7" H x 19.0" W x 12.8" D (44 mm x 483 mm x 324 mm)
Shipping Weight	11.5 lb (5.2 kg)
Net Weight	8.5 lb (3.9 kg)
Cooling System	Single fan creates continuous left-to-right air flow
General	
Inputs (Control)	2 remote inputs for Volume Control user interface (PC041966), Mute input control via a normally open contact closure

FreeSpace® ZA 2120-HZ Zone Amplifier

BOSE

TECHNICAL DATA SHEET



- 1 **POWER switch** – ON/OFF AC power.
- 2 **Power LED** – Solid blue LED indicates the unit is ON. Blinking blue LED indicates the unit is in standby mode.
- 3 **INPUT SIGNAL LED** – LED is green from -37 dBu to 11 dBu, LED goes red over 11 dBu.
- 4 **OUTPUT LIMIT LED** – LED is green from -46 dBFS to -2 dBFS, LED goes red over -2 dBFS, approximately 80 W/channel. For each output, 120 watts is 0 dBFS.

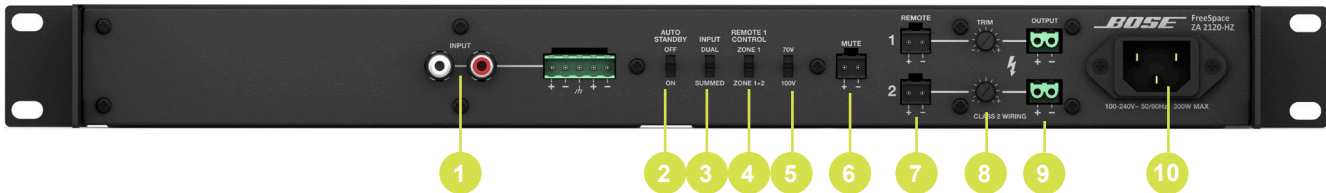

- 1 **INPUT** – Balanced and unbalanced line-level input connectors.
- 2 **AUTO STANDBY** – If enabled (ON) the amplifier will go into standby mode after twenty minutes without an input signal. If in standby mode and an audio signal is detected, the amplifier will automatically wake and amplify audio within 0.7 seconds. The OFF position disables the feature.
- 3 **INPUT** – The input can be set to either DUAL mono inputs or SUMMED to one mono input.
- 4 **REMOTE 1 CONTROL** – Sets the REMOTE 1 input to control both outputs (or zones) simultaneously (ZONE 1+2), or allows each REMOTE input to control its own output (ZONE 1). If only one remote is being used, then this switch must be set to ZONE 1+2.
- 5 **70V/100V** – The output can be set to 70 V or 100 V.
- 6 **MUTE** – Contact closure connection that upon trigger (short) will mute all outputs.
- 7 **REMOTE** – Input connectors for the Bose® volume control user interface accessory (PC 041966).
- 8 **OUTPUT TRIM** – Allows for up to 40 dB attenuation of each loudspeaker output.
- 9 **OUTPUT** – Two inverted 2-pin Euroblock connectors for loudspeaker connections. Outputs are not bridgeable.
- 10 **AC Mains receptacle** – AC line voltage input.

FreeSpace® ZA 2120-HZ Zone Amplifier



AC Current Draw and Thermal Dissipation Information

Test Signal & Power Level	Load Configuration (Both IZA channels driven)	Total Audio Output, W	120VAC 60Hz. Line Current, A	230VAC 50Hz. Line Current, A	Thermal Dissipation, Max		
					Watts	BTU/hr.	kCal/hr.
Power On, Idling		0	0.20	0.15	34	116	29
1/8th Rated Power IEC65 Bandlimited Pink Noise	70V / Ch	30	0.57	0.31	71	242	61
6 dB Crest Factor DS 16 EQ Enabled	100V / Ch	30	0.66	0.35	81	276	71
1/3rd Rated Power IEC65 Bandlimited Pink Noise	70V / Ch	80	1.13	0.58	133	454	114
6 dB Crest Factor DS 16 EQ Enabled	100V / Ch	80	1.25	0.65	150	512	129

Mechanical Diagrams

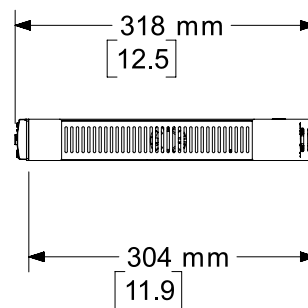
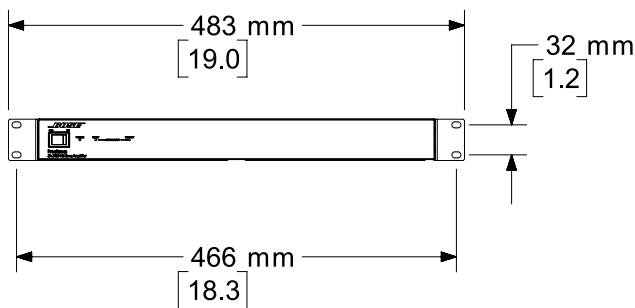
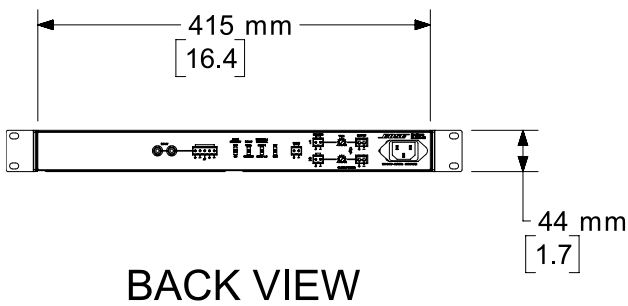

FreeSpace® ZA 2120-HZ Zone Amplifier



Architects' and Engineers' Specifications

The amplifier shall employ Class-D amplification topology. The amplifier shall incorporate a switch-mode power supply allowing normal operation from AC outlets ranging from 100 – 240 V ($\pm 10\%$) at 50/60 Hz. The amplifier shall have an IEC 320-C14 electrical power inlet and shall be equipped with a removable power supply cord. A power switch shall be located on the front panel. The product shall include protection from shorted loads and general overheating. The amplifier's physical size shall be 1 RU in height by 1 RU in width and be capable of rack mounting. The product shall have venting with a single fan, continuous left-to-right airflow. Each output channel shall have output trim controls.

The amplifier shall have two output channels with a frequency response of 55 Hz to 20 kHz ($+0/-3$ dB) and drive 70/100V distributed audio systems. The amplifier shall have THD+N at rated power less than or equal to 0.3%. Output connections shall be made via 2-pin touch-proof Euroblock connectors.

The amplifier shall meet or exceed the following performance specifications: channel separation (crosstalk) less than or equal to -58 dBu below rated power at 1 kHz and dynamic range of 88 dB. The amplifier shall have 1 line-level input (RCA stereo or 5-pin Euroblock) and 1 remote control input. Three LEDs shall be visible on the front panel – one (blue) for power/standby indication, the second (red) for input level over 11 dBu, and the third (red) for output level over -2 dBFS.

The amplifier shall have 2 remote control inputs intended for use with the Bose Volume control user interface or third party 10k ohm linear taper potentiometers. The amplifier shall offer a master mute connection for use with external dry contacts to mute output of the amplifier. The rear panel shall contain a dual/summed input switch that allows optimization of the amplifier input.

The amplifier chassis shall be constructed of painted steel. The dimensions of the amplifier shall allow for 19-inch (483 mm) EIA standard rack mounting. The chassis shall be 1.7 inches (44 mm) in height, 19.0 inches (483 mm) in width and 12.8 inches (324 mm) in depth. The amplifier chassis shall weigh 8.5 pounds (3.9 kg). The amplifier shall be the Bose FreeSpace ZA 2120-HZ zone amplifier.

Safety and Regulatory Compliance

The FreeSpace ZA 2120-HZ zone amplifier complies with CE requirements and is UL listed according to UL60065 (7th edition) and CAN/CSA C22.2 No. 60065-03; CB approved, according to IEC60065 (7th edition), including group and national differences. This model also complies with FCC Part 15B Class A (2003), EN55103-1 (1997), EN55103-2 (1996), and CISPR13 (2003) requirements.

Product Codes

FreeSpace ZA 2120-HZ integrated zone amplifier

120V – US	722196-1410
230V – EU	722196-2410
100V – Japan	722196-3410
230V – UK	722196-4410
240V – AU	722196-5410

Accessories

Volume control user interface (PC041966)