

Description

Rane takes performance mixer design as seriously as performing DJs take their art form. The TTM 56S is flexible, durable, and feature packed. The audio quality of the TTM 56S qualifies it for use in the most demanding live venue, recording studio or live broadcast applications.

Non-Contact Magnetic Crossfader and Channel Faders

Rane's magnetic fader is the fastest, most accurate, and longest lasting on the planet. The design uses non-contact magnetic position sensor technology previously reserved for the most demanding aerospace and industrial applications. *No travel noise - No bleed - Ever!* Unlike optical non-contact faders, the magnetic fader is impervious to smoke, moisture, temperature and aging. The electrical performance is totally unaffected by use. The mechanical life of the magnetic fader exceeds 10 million operations.

These magnetic faders know exactly what your hand is doing! A proprietary curve-translation module converts your hand motion into precise audio level control. Each of the Crossfader and Channel Fader controls includes a Reverse switch and an *independent* continuously adjustable Contour control, adjusting from a smooth blend to extremely fast cut.

Post-Fader FlexFx™

Rane's proprietary FlexFx effects loop switches route Program 1 and/or Program 2 to the effects loop. A Wet/Dry pan control gives the user total control of how much processed signal is in the mix. The effects loop is *post-fader*, so reverb and other delay effects respond to both Channel Faders and Crossfader without cutting off tails.

Stereo Metering

The TTM 56S features two 10-segment meters with peak-hold. A source switch allows users to select dual-mono Cue *or* Stereo Master operation. No stress about dropping a channel without knowing.

Auxiliary Input and Output (Session Mix)

A stereo Aux Input with a Level control provides input for a session mix, drum machine or another auxiliary input signal. The stereo Aux Output with Level control provides output for session mix, booth monitoring, recording or second zone.

3-Band Accelerated-Slope™ Full-Cut EQ

The TTM 56S provides 3-band, full cut tone controls for Program 1 and Program 2. EQ engage switches allow A/B comparison and the ability to quickly cut or add EQ effect.

TTM 56 to TTM 56S

The TTM 56 has been the world's most popular battle DJ mixer for many years. The new TTM 56S improves with a universal internal power supply that works almost anywhere in the world (100-240 VAC). All four inputs are now Phono/Line switchable, now letting you plug in 4 turntables or 4 CD players, or any combination. Both ¼" and 3.5 mm headphone jacks are now provided. The Transform switches are now Kill switches, and the occasionally confusing and rarely-used Mode switches have been removed. Operation is simplified by putting all the controls you need on top, and increasing the width by one inch.



Parameter	Specification	Conditions & Comments
Program Inputs: Phono:	Switchable Line / Phono	Unbalanced RCA jacks
.....Response	RIAA	±1 dB
.....Gain	35 dB	1 kHz
.....Maximum Phono Input	138 mV	
.....Input Impedance	47.5 kΩ, 200 pF	
.....Line:	Switchable Line / Phono	Unbalanced RCA jacks
.....Gain	Off to +12 dB	1 kHz
.....Input Impedance	20 kΩ	1 kHz
.....Tone Control (EQ)	3-Band, Accelerated-Slope™	Full Cut, see figures on next page
Auxiliary Input:	1 stereo	Unbalanced RCA jacks
.....Input Impedance	20 kΩ	1 kHz
.....Gain	Off to +10 dB	1 kHz
FlexFX Return:	Stereo	Unbalanced ¼" TS (tip-sleeve) phone jack
.....Input Impedance	12 kΩ	Minimum
.....Gain	Unity	1 kHz
Mic Input:	Active Balanced	Balanced ¼" TRS (tip-ring-sleeve) phone jack
.....Input Impedance	20 kΩ	10 kΩ, each leg to ground
.....Gain	44 dB	1 kHz, Master Out, max gain
.....Frequency Response	30 to 20 kHz	+0, -3 dB, max gain
.....CMMR	>40 dB	1 kHz, max gain
.....S/N	76 dB	Re +4 dBu, max gain, @ insert, 20 kHz BW
.....Tone Control	2-Band	See Figure in Manual
.....Effects Insert Loop	¼" TRS, Tip=Send, Ring=Return	Unbalanced mono
Master Output:	Stereo balanced / unbalanced	¼" TRS phone / RCA jacks
.....Output Impedance	300 Ω balanced each leg	301Ω unbalanced
.....Gain	6 dB balanced	0 dB unbalanced
.....Frequency Response	10 Hz to 30 kHz	+0, -3 dB
.....THD+N	<0.05%	re +4 dBu, 20 to 20 kHz, 20 kHz BW
.....S/N (balanced output)	101 dB	re +4 dBu, 20 kHz BW, unity gain
	94 dB	re +4 dBu, 20 kHz BW, 12 dB gain
Auxiliary Output:	Stereo	Unbalanced RCA jacks
.....Output Impedance	301 Ω	
.....Gain	Off to +6 dB	
FlexFX Send:	Stereo	Unbalanced ¼" TS phone jack
.....Output Impedance	301 Ω	Unity Gain
General Specifications:		
.....Control Feed-through	-80 dB	re +4 dBu, all controls
.....Crosstalk	-70 dB	re +4 dBu, 1 kHz
Unit: Conformity	CE, FCC, cULus	
.....Universal Line Voltage	100-240 VAC	50-60 Hz
.....Maximum Power	20 W	
.....Front Panel Size	13.3"H x 10"W	(33.8 cm x 25.4 cm)
.....Coffin Depth	3" (see detail)	(7.7 cm)
.....Weight	9 lb	(3.7 kg)
Shipping: Size	7.75"H x 12.75"W x 19.25"D	(19.7 x 32.5 x 49 cm)
.....Weight	12 lb	(5.5 kg)

Note: All specifications are typical unless otherwise stated.

EQ Control Response

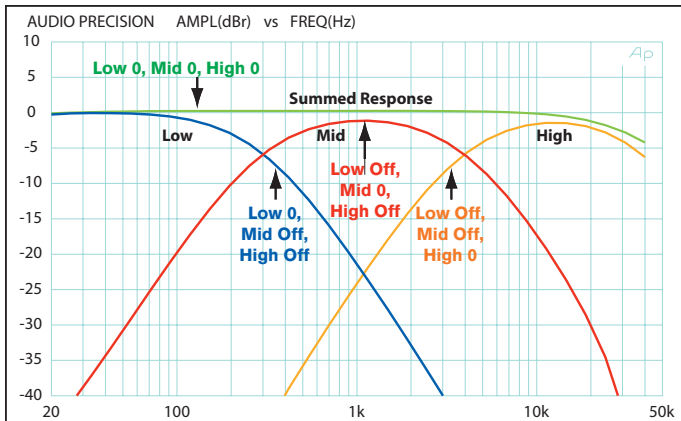

Figure 1 shows the three EQ bands and the flat summed response

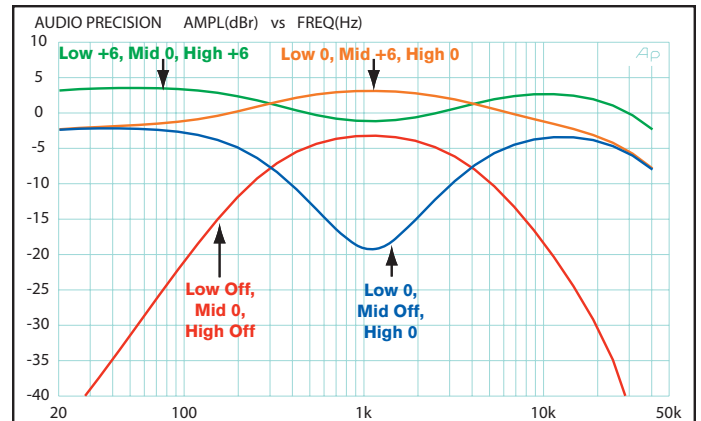
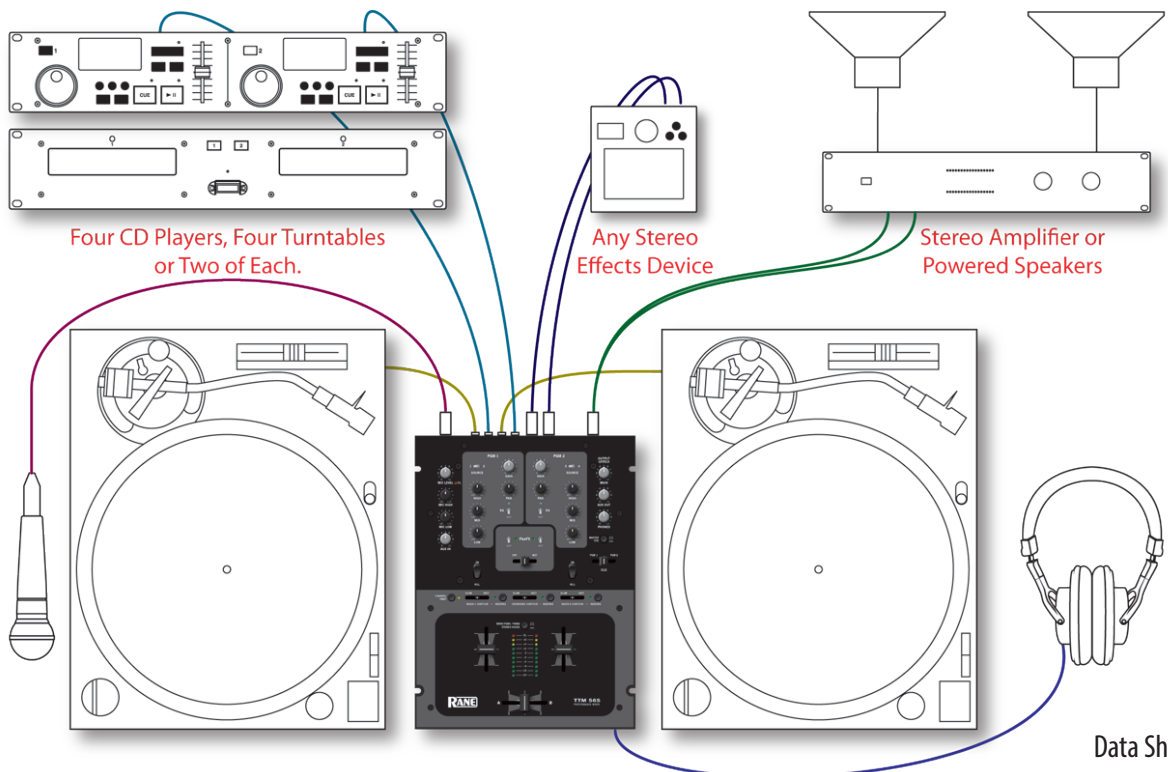

Figure 2 shows the interactive operation of the three EQ controls

Features

- Non-contact magnetic program faders and crossfader.
- Continuously adjustable Contour adjustments for all faders.
- **Program 1** and **Program 2** Input Buses with:
 - 2 **Phono / Line** switchable inputs with **Kill** switch.
 - Input **Gain** control.
 - 3-band **Accelerated-Slope™**, full cut (+6 dB to off) **EQ**.
 - **FlexFX™** effects loop assignment with **Wet / Dry** control.
- **Auxiliary** (session mix) **Input / Output** with **Level** controls.
- Balanced **Mic** input with **Level** control with:
 - **2-band EQ** and independent **Effects Loop**.
- Independent **Balanced** and **unbalanced Master Outputs**.
- Two 10-segment meters feature peak-hold with:
 - **Source** switch for **dual-mono Cue** or **stereo Master**.
- Headphone monitoring with:
 - **Master / Cue** select switch with **Cue Pan** control.
 - Powerful headphone amplifier with **Level** control.
- Top panel is luminescent under black light.

Example System



TTM 56S

PERFORMANCE MIXER



Rear View

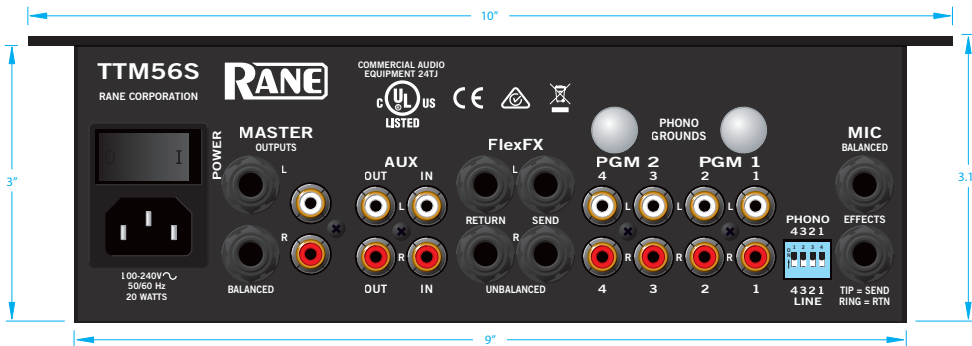

Side View

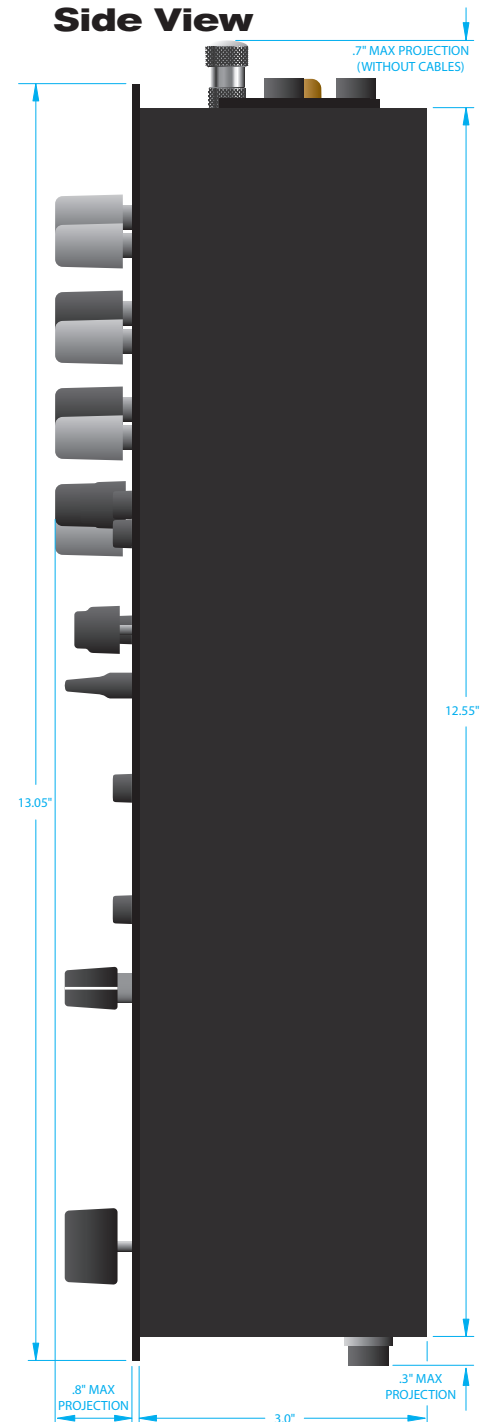

dj.rane.com

Visit the Rane DJ website for the most up-to-date information on all Rane hardware, manuals, accessories, support, community, newsletter and blog.

Front View



Views are 50% actual size